



Switched-Capacitor Voltage Inverters

General Description

The ultra-small MAX870/MAX871 monolithic, CMOS charge-pump inverters accept input voltages ranging from +1.4V to +5.5V. The MAX870 operates at 125kHz, and the MAX871 operates at 500kHz. Their high efficiency (90%) and low operating current (0.7mA for the MAX870) make these devices ideal for both battery-powered and board-level voltage-conversion applications.

Oscillator control circuitry and four power MOSFET switches are included on-chip. A typical MAX870/MAX871 application is generating a -5V supply from a +5V logic supply to power analog circuitry. Both parts come in a 5-pin SOT23-5 package and can deliver 25mA with a voltage drop of 500mV.

For applications requiring more power, the MAX860 delivers up to 50mA with a voltage drop of 600mV, in a space-saving μ MAX package.

Applications

- Local -5V Supply from 5V Logic Supply
- Small LCD Panels
- Cell Phones
- Medical Instruments
- Handy-Terminals, PDAs
- Battery-Operated Equipment

Typical Operating Circuit

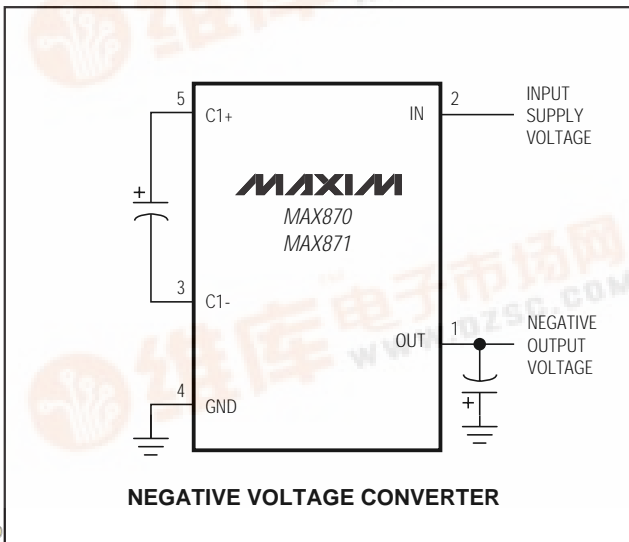

Features

- ◆ 5-Pin SOT23-5 Package
- ◆ 99% Voltage Conversion Efficiency
- ◆ Invert Input Supply Voltage
- ◆ 0.7mA Quiescent Current (MAX870)
- ◆ +1.4V to +5.5V Input Voltage Range
- ◆ Require Only Two Capacitors
- ◆ 25mA Output Current
- ◆ Shutdown Control

Ordering Information

PART	TEMP. RANGE	PIN-PACKAGE	SOT TOP MARK
MAX870C/D	0°C to +70°C	Dice*	—
MAX870EUK	-40°C to +85°C	5 SOT23-5	ABZN
MAX871C/D	0°C to +70°C	Dice*	—
MAX871EUK	-40°C to +85°C	5 SOT23-5	ABZO

* Dice are tested at $T_A = +25^\circ\text{C}$.

Pin Configuration

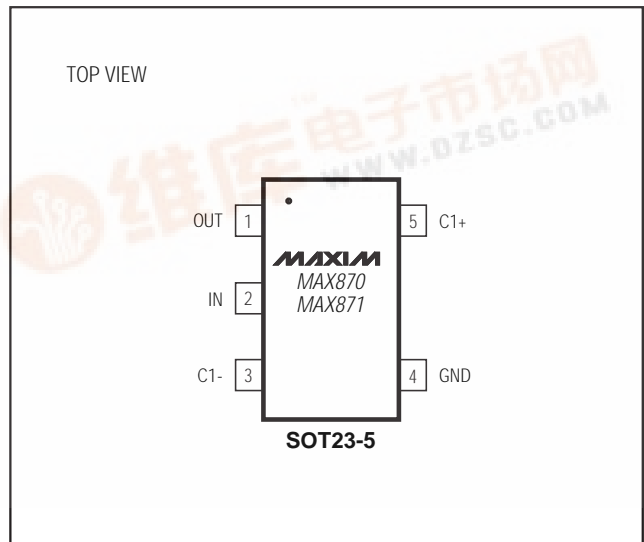

MAX870/MAX871

Switched-Capacitor Voltage Inverters

ABSOLUTE MAXIMUM RATINGS

IN to GND	+6.0V to -0.3V	Continuous Power Dissipation ($T_A = +70^\circ\text{C}$)	
OUT to GND	-6.0V to +0.3V	SOT23-5 (derate 7.1mW/°C above +70°C).....	571mW
C1+	($V_{IN} + 0.3V$) to -0.3V	Operating Temperature Range	
C1-	($V_{OUT} - 0.3V$) to +0.3V	MAX870EUK/MAX871EUK	-40°C to +85°C
OUT Output Current50mA	Storage Temperature Range	-65°C to +160°C
OUT Short Circuit to GND	Indefinite	Lead Temperature (soldering, 10sec)	+300°C

Stresses beyond those listed under "Absolute Maximum Ratings" may cause permanent damage to the device. These are stress ratings only, and functional operation of the device at these or any other conditions beyond those indicated in the operational sections of the specifications is not implied. Exposure to absolute maximum rating conditions for extended periods may affect device reliability.

ELECTRICAL CHARACTERISTICS

($V_{IN} = +5V$, $C1 = C2 = 1\mu\text{F}$ (MAX870), $C1 = C2 = 0.33\mu\text{F}$ (MAX871), $T_A = 0^\circ\text{C}$ to $+85^\circ\text{C}$, unless otherwise noted. Typical values are at $T_A = +25^\circ\text{C}$.)

PARAMETER	CONDITIONS		MIN	TYP	MAX	UNITS	
Supply Current	$T_A = +25^\circ\text{C}$	MAX870		0.7	1.0	mA	
		MAX871		2.7	3.8		
Minimum Supply Voltage	$R_{LOAD} = 10k\Omega$	$T_A = +25^\circ\text{C}$	1.4	1.0		V	
		$T_A = 0^\circ\text{C}$ to $+85^\circ\text{C}$	1.5				
Maximum Supply Voltage	$R_{LOAD} = 10k\Omega$				5.5	V	
Oscillator Frequency	$T_A = +25^\circ\text{C}$	MAX870	81	125	169	kHz	
		MAX871	325	500	675		
Power Efficiency	$R_{LOAD} = 500k\Omega$, $T_A = +25^\circ\text{C}$	MAX870		90		%	
		MAX871		75			
Voltage Conversion Efficiency	$R_{LOAD} = \infty$, $T_A = +25^\circ\text{C}$	MAX870	98	99.3		%	
		MAX871	96	99			
Output Resistance (Note 1)	$I_{OUT} = 5\text{mA}$	$T_A = +25^\circ\text{C}$	MAX870	$C1 = C2 = 1\mu\text{F}$	20	50	Ω
				$C1 = C2 = 0.47\mu\text{F}$	25		
		$T_A = 0^\circ\text{C}$ to $+85^\circ\text{C}$	MAX871	$C1 = C2 = 0.33\mu\text{F}$	20	50	
				$C1 = C2 = 0.22\mu\text{F}$	25		
				$C1 = C2 = 0.1\mu\text{F}$	35		
					65		

Note 1: Capacitor contribution is approximately 20% of the output impedance [ESR + $1 / (\text{pump frequency} \times \text{capacitance})$].

ELECTRICAL CHARACTERISTICS

($V_{IN} = +5V$, $C1 = C2 = 1\mu\text{F}$ (MAX870), $C1 = C2 = 0.33\mu\text{F}$ (MAX871), $T_A = -40^\circ\text{C}$ to $+85^\circ\text{C}$, unless otherwise noted.) (Note 2)

PARAMETER	CONDITIONS		MIN	TYP	MAX	UNITS
Supply Current		MAX870			1.3	mA
		MAX871			4.4	
Minimum Supply-Voltage Range	$R_{LOAD} = 10k\Omega$		1.6			V
Maximum Supply-Voltage Range	$R_{LOAD} = 10k\Omega$				5.5	V
Oscillator Frequency		MAX870	56	194		kHz
		MAX871	225	775		
Output Resistance	$I_{OUT} = 5\text{mA}$				65	Ω
Voltage Conversion Efficiency	$R_{LOAD} = \infty$	MAX870	97			%
		MAX871	95			

Note 2: All -40°C to $+85^\circ\text{C}$ specifications are guaranteed by design.

Switched-Capacitor Voltage Inverters

Typical Operating Characteristics

(Circuit of Figure 1, $V_{IN} = +5V$, $C_1 = C_2 = C_3$, $T_A = +25^\circ C$, unless otherwise noted.)

MAX870/MAX871

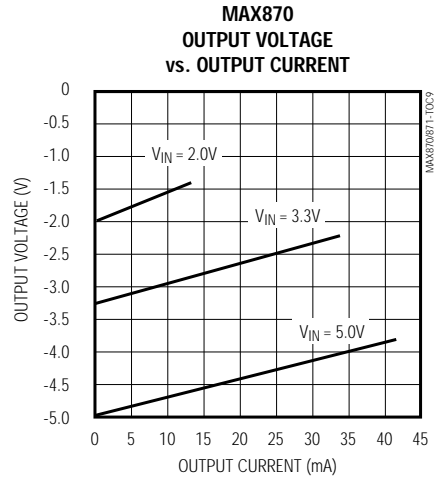
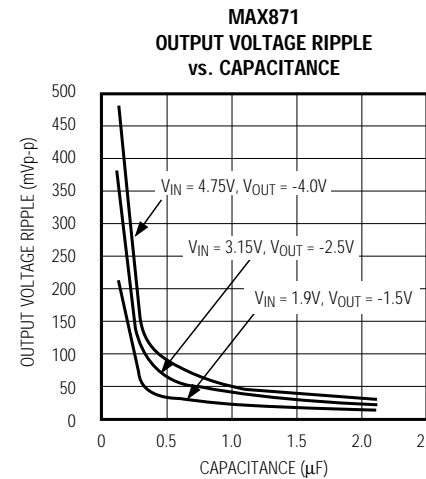
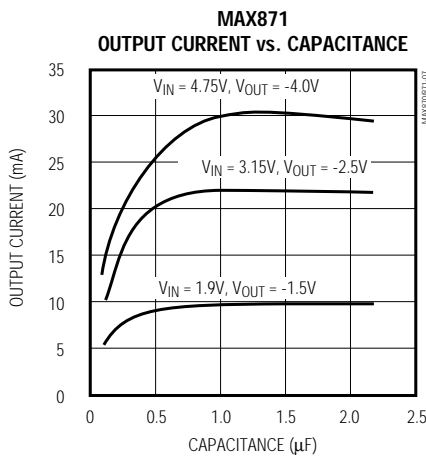
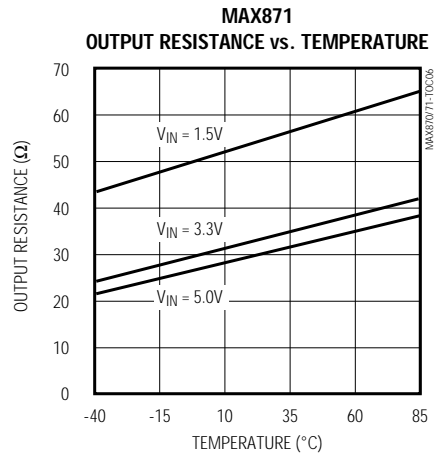
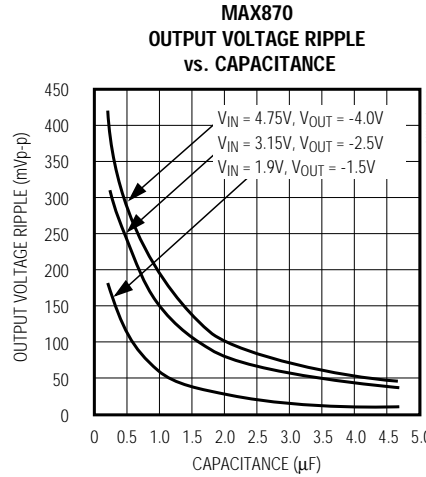
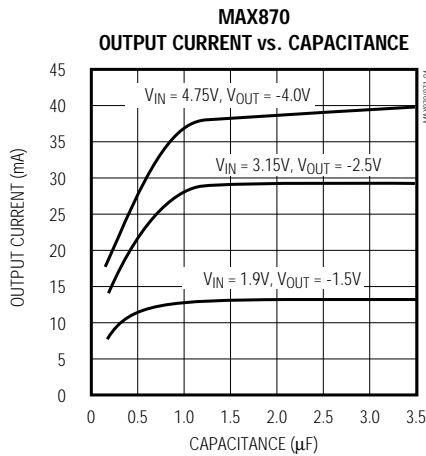
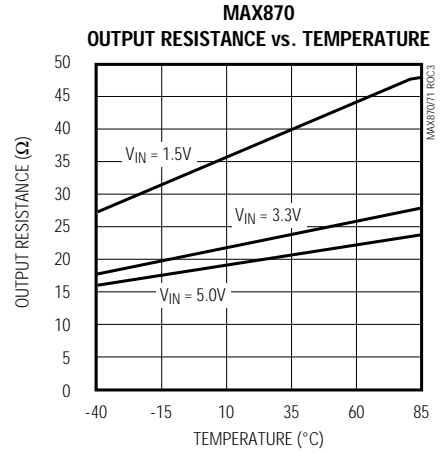
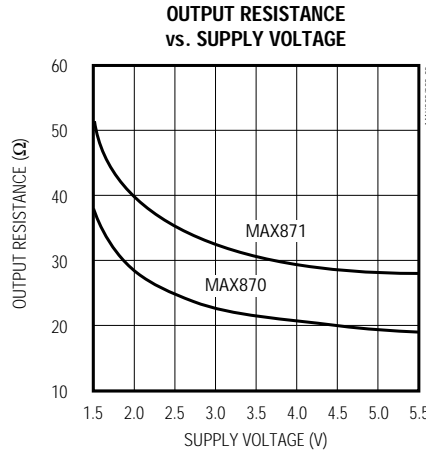
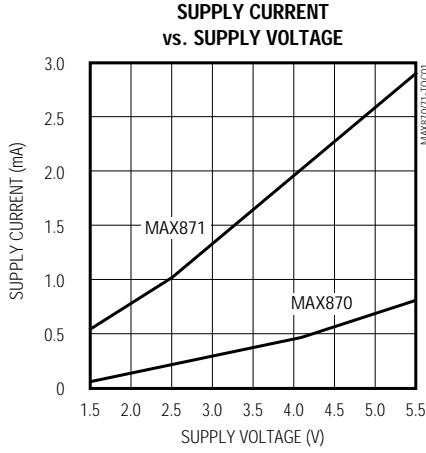

Switched-Capacitor Voltage Inverters

Typical Operating Characteristics (continued)

(Circuit of Figure 1, $V_{IN} = +5V$, $C1 = C2 = C3$, $T_A = +25^\circ C$, unless otherwise noted.)

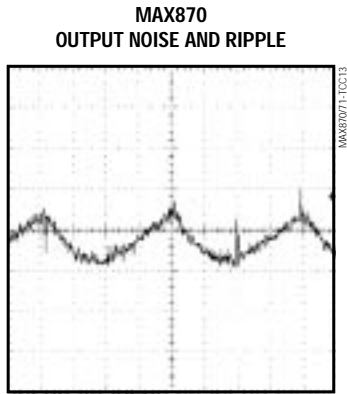
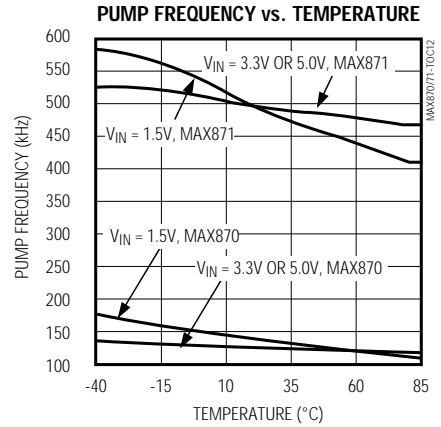
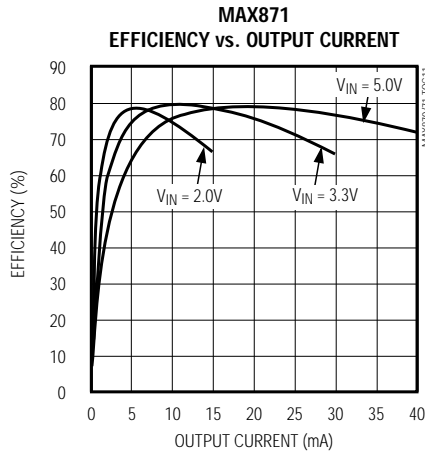
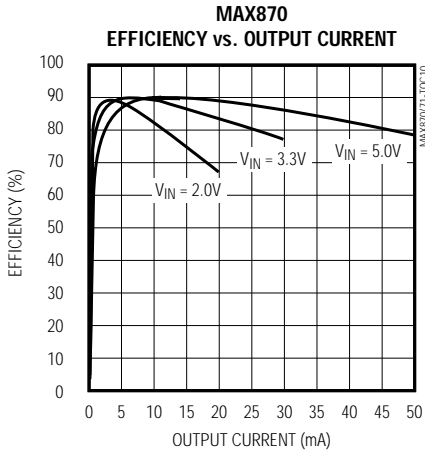

$V_{IN} = 3.3V$, $V_{OUT} = -3.18V$, $I_{OUT} = 5mA$,
 $20mV/div$, AC COUPLED

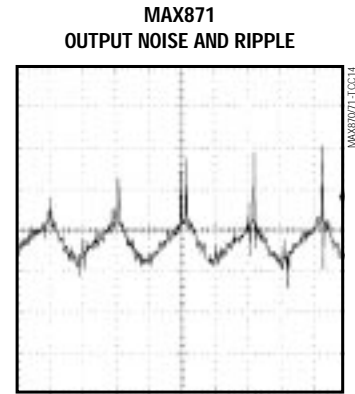

$V_{IN} = 3.3V$, $V_{OUT} = -3.14V$, $I_{OUT} = 5mA$,
 $20mV/div$, AC COUPLED

Pin Description

PIN	NAME	FUNCTION
1	OUT	Inverting Charge-Pump Output
2	IN	Positive Power-Supply Input
3	C1-	Flying Capacitor's Negative Terminal
4	GND	Ground
5	C1+	Flying Capacitor's Positive Terminal

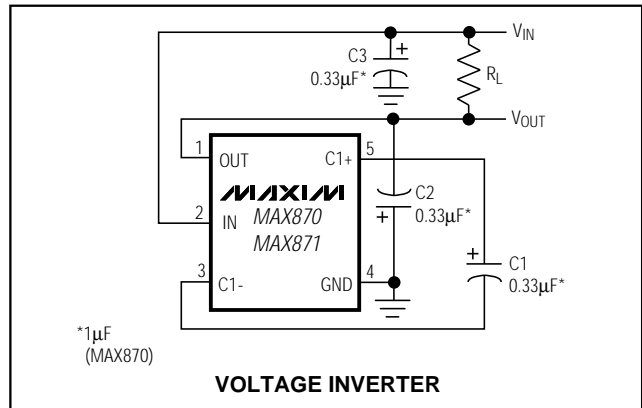

Figure 1. Test Circuit

Switched-Capacitor Voltage Inverters

Detailed Description

The MAX870/MAX871 capacitive charge pumps invert the voltage applied to their input. For highest performance, use low equivalent series resistance (ESR) capacitors (e.g., ceramic).

During the first half-cycle, switches S2 and S4 open, switches S1 and S3 close, and capacitor C1 charges to the voltage at IN (Figure 2). During the second half-cycle, S1 and S3 open, S2 and S4 close, and C1 is level shifted downward by V_{IN} volts. This connects C1 in parallel with the reservoir capacitor C2. If the voltage across C2 is smaller than the voltage across C1, then charge flows from C1 to C2 until the voltage across C2 reaches $-V_{IN}$. The actual voltage at the output is more positive than $-V_{IN}$, since switches S1–S4 have resistance and the load drains charge from C2.

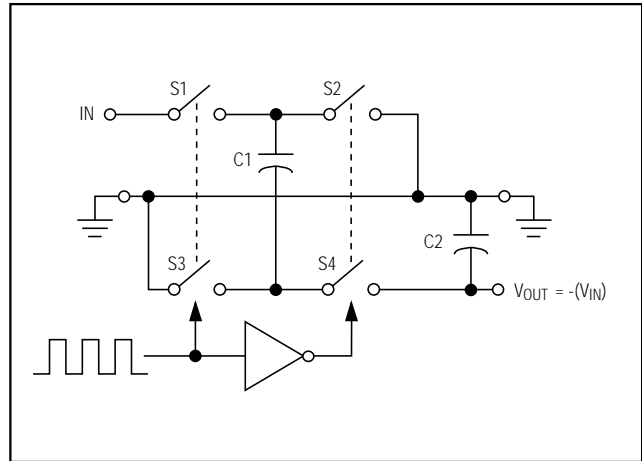

Figure 2. Ideal Voltage Inverter

Charge-Pump Output

The MAX870/MAX871 are not voltage regulators: the charge pump's output source resistance is approximately 20Ω at room temperature (with $V_{IN} = +5V$), and V_{OUT} approaches $-5V$ when lightly loaded. V_{OUT} will droop toward GND as load current increases. The droop of the negative supply (V_{DROOP-}) equals the current draw from OUT (I_{OUT}) times the negative converter's source resistance (R_{S-}):

$$V_{DROOP-} = I_{OUT} \times R_{S-}$$

The negative output voltage will be:

$$V_{OUT} = -(V_{IN} - V_{DROOP-})$$

Efficiency Considerations

The power efficiency of a switched-capacitor voltage converter is affected by three factors: the internal losses in the converter IC, the resistive losses of the pump capacitors, and the conversion losses during charge transfer between the capacitors. The total power loss is:

$$\begin{aligned} \Sigma P_{LOSS} &= P_{INTERNAL\ LOSSES} + P_{SWITCH\ LOSSES} \\ &+ P_{PUMP\ CAPACITOR\ LOSSES} \\ &+ P_{CONVERSION\ LOSSES} \end{aligned}$$

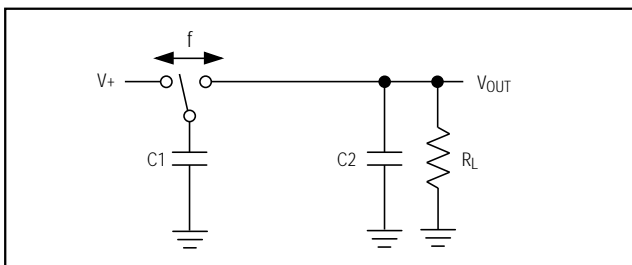

Figure 3a. Switched-Capacitor Model

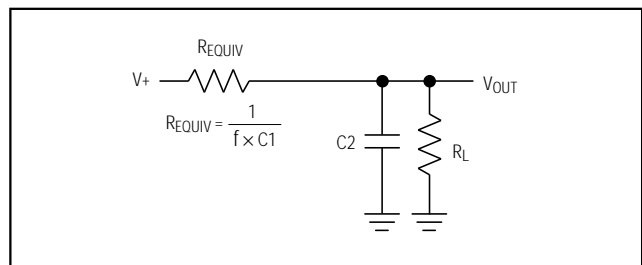

Figure 3b. Equivalent Circuit

The internal losses are associated with the IC's internal functions, such as driving the switches, oscillator, etc. These losses are affected by operating conditions such as input voltage, temperature, and frequency.

The next two losses are associated with the voltage converter circuit's output resistance. Switch losses occur because of the on-resistance of the MOSFET switches in the IC. Charge-pump capacitor losses occur because of their ESR. The relationship between these losses and the output resistance is as follows:

$$\begin{aligned} P_{PUMP\ CAPACITOR\ LOSSES} + P_{CONVERSION\ LOSSES} \\ &= I_{OUT}^2 \times R_{OUT} \\ R_{OUT} &\cong \frac{1}{(f_{OSC}) \times C1} + 2R_{SWITCHES} + 4ESR_{C1} + ESR_{C2} \end{aligned}$$

where f_{OSC} is the oscillator frequency. The first term is the effective resistance from an ideal switched-capacitor circuit. See Figures 3a and 3b.

Switched-Capacitor Voltage Inverters

Conversion losses occur during the charge transfer between C1 and C2 when there is a voltage difference between them. The power loss is:

$$P_{\text{CONV.LOSS}} = \left[\frac{1}{2} C_1 \left(V_{\text{IN}}^2 - V_{\text{OUT}}^2 \right) + \frac{1}{2} C_2 \left(V_{\text{RIPPLE}}^2 - 2V_{\text{OUT}} V_{\text{RIPPLE}} \right) \right] \times f_{\text{OSC}}$$

Applications Information

Capacitor Selection

To maintain the lowest output resistance, use capacitors with low ESR (Table 1). The charge-pump output resistance is a function of C1's and C2's ESR. Therefore, minimizing the charge-pump capacitor's ESR minimizes the total output resistance.

Flying Capacitor (C1)

Increasing the flying capacitor's size reduces the output resistance. Small C1 values increase the output resistance. Above a certain point, increasing C1's capacitance has a negligible effect, because the output resistance becomes dominated by the internal switch resistance and capacitor ESR.

Output Capacitor (C2)

Increasing the output capacitor's size reduces the output ripple voltage. Decreasing its ESR reduces both output resistance and ripple. Smaller capacitance values can be used with light loads if higher output ripple can be tolerated. Use the following equation to calculate the peak-to-peak ripple:

$$V_{\text{RIPPLE}} = \frac{I_{\text{OUT}}}{f_{\text{OSC}} \times C_2} + 2 \times I_{\text{OUT}} \times \text{ESR}_{C_2}$$

Input Bypass Capacitor

Bypass the incoming supply to reduce its AC impedance and the impact of the MAX870/MAX871's switching

noise. The recommended bypassing depends on the circuit configuration and on where the load is connected.

When the inverter is loaded from OUT to GND, current from the supply switches between $2 \times I_{\text{OUT}}$ and zero. Therefore, use a large bypass capacitor (e.g., equal to the value of C1) if the supply has a high AC impedance.

When the inverter is loaded from IN to OUT, the circuit draws $2 \times I_{\text{OUT}}$ constantly, except for short switching spikes. A 0.1 μ F bypass capacitor is sufficient.

Voltage Inverter

The most common application for these devices is a charge-pump voltage inverter (Figure 1). This application requires only two external components—capacitors C1 and C2—plus a bypass capacitor, if necessary. Refer to the *Capacitor Selection* section for suggested capacitor types.

Cascading Devices

Two devices can be cascaded to produce an even larger negative voltage (Figure 4). The unloaded output voltage is normally $-2 \times V_{\text{IN}}$, but this is reduced slightly by the output resistance of the first device multiplied by the quiescent current of the second. When cascading more than two devices, the output resistance rises dramatically. For applications requiring larger negative voltages, see the MAX864 and MAX865 data sheets.

Paralleling Devices

Paralleling multiple MAX870s or MAX871s reduces the output resistance. Each device requires its own pump capacitor (C1), but the reservoir capacitor (C2) serves all devices (Figure 5). Increase C2's value by a factor of n, where n is the number of parallel devices. Figure 5 shows the equation for calculating output resistance.

Combined Doubler/Inverter

In the circuit of Figure 6, capacitors C1 and C2 form the inverter, while C3 and C4 form the doubler. C1 and C3 are the pump capacitors; C2 and C4 are the reservoir

Table 1. Low-ESR Capacitor Manufacturers

PRODUCTION METHOD	MANUFACTURER	SERIES	PHONE	FAX
Surface-Mount Tantalum	AVX	TPS series	(803) 946-0690	(803) 626-3123
	Matsuo	267 series	(714) 969-2491	(714) 960-6492
	Sprague	593D, 595D series	(603) 224-1961	(603) 224-1430
Surface-Mount Ceramic	AVX	X7R	(803) 946-0690	(803) 626-3123
	Matsuo	X7R	(714) 969-2491	(714) 960-6492

Switched-Capacitor Voltage Inverters

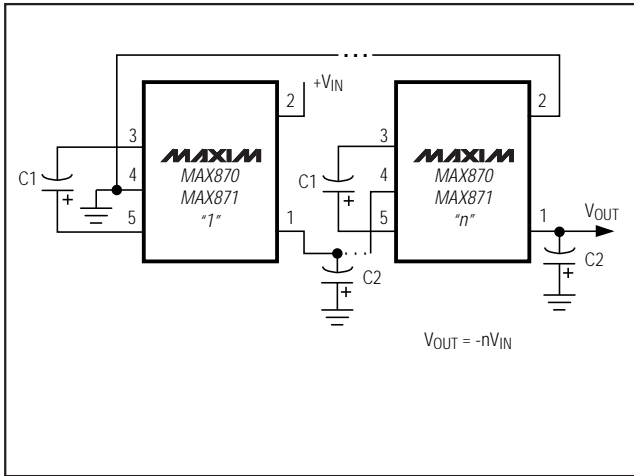

Figure 4. Cascading MAX870s or MAX871s to Increase Output Voltage

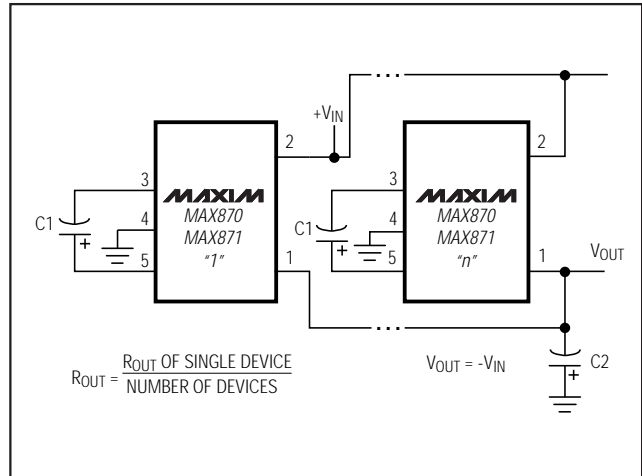

Figure 5. Paralleling MAX870s or MAX871s to Reduce Output Resistance

capacitors. Because both the inverter and doubler use part of the charge-pump circuit, loading either output causes both outputs to decline toward GND. Make sure the sum of the currents drawn from the two outputs does not exceed 40mA.

Heavy Output Current Loads

Under heavy loads, where higher supply is sourcing current into OUT, the OUT supply must not be pulled above ground. Applications that sink heavy current into OUT require a Schottky diode (1N5817) between GND and OUT, with the anode connected to OUT (Figure 7).

Layout and Grounding

Good layout is important, primarily for good noise performance. To ensure good layout, mount all components as close together as possible, keep traces short to minimize parasitic inductance and capacitance, and use a ground plane.

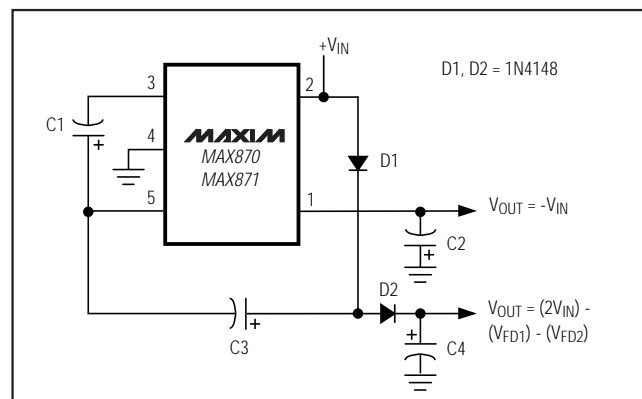

Figure 6. Combined Doubler and Inverter

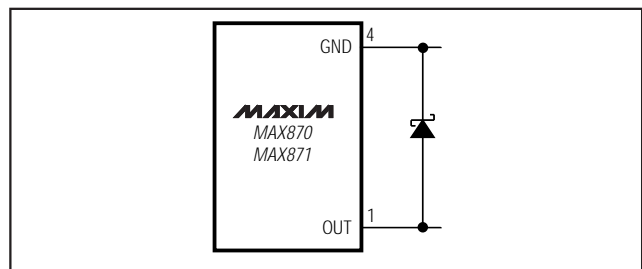

Figure 7. High V- Load Current

Switched-Capacitor Voltage Inverters

Shutdown Control

If shutdown control is necessary, use the circuit in Figure 8. The output resistance of the MAX870/MAX871 will typically be 20Ω plus two times the output resistance of the buffer driving IN. The $0.1\mu\text{F}$ capacitor at the IN pin absorbs the transient input currents of the MAX870/MAX871.

The output resistance of the buffer driving the IN pin can be reduced by connecting multiple buffers in parallel. The polarity of the shutdown signal can also be changed by using a noninverting buffer to drive IN.

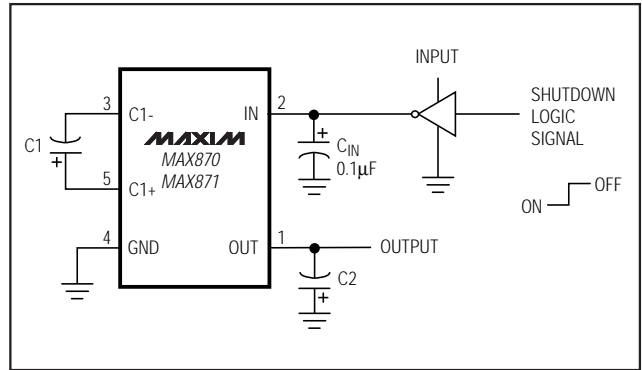
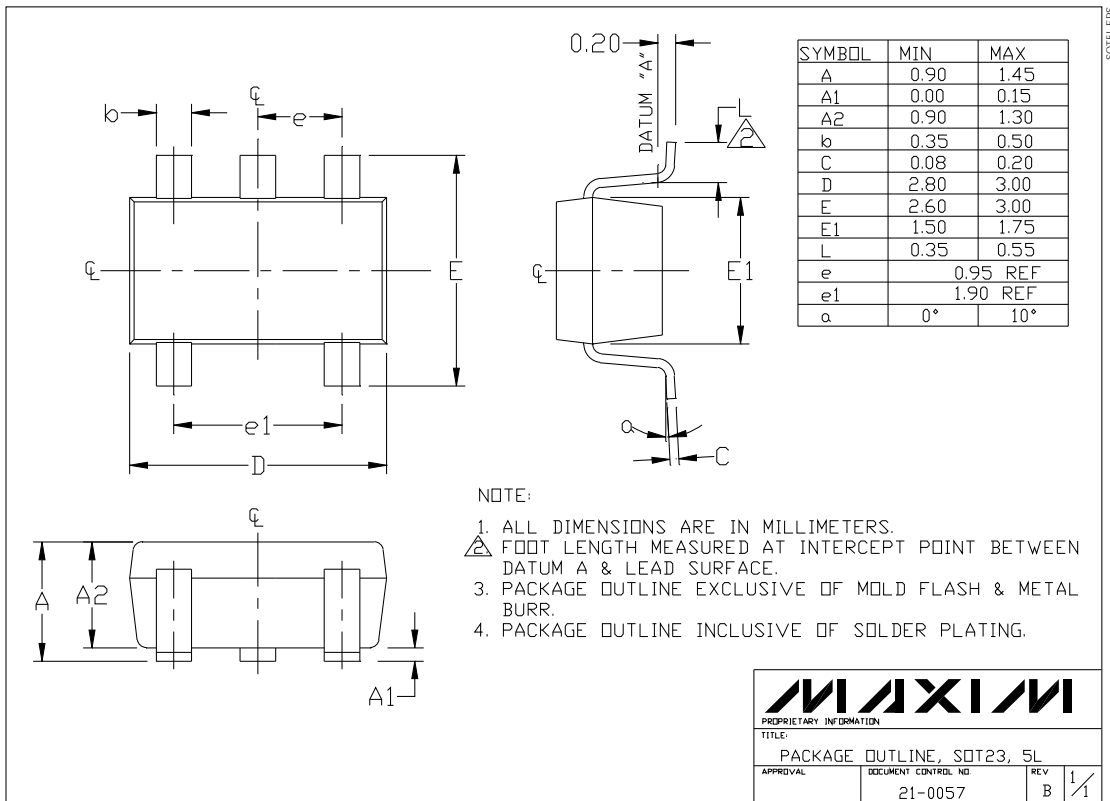

Figure 8. Shutdown Control

Chip Information

TRANSISTOR COUNT: 58
SUBSTRATE CONNECTED TO IN

Package Information



Maxim cannot assume responsibility for use of any circuitry other than circuitry entirely embodied in a Maxim product. No circuit patent licenses are implied. Maxim reserves the right to change the circuitry and specifications without notice at any time.

8 Maxim Integrated Products, 120 San Gabriel Drive, Sunnyvale, CA 94086 (408) 737-7600