



AVAILABLE
AN99 • AN115 • AN120 • AN124 • AN133 • AN134

Low Noise, Low Power, Low Cost

X9116

Digitally Controlled Potentiometer (XDCCP™)

FEATURES

- Solid-state nonvolatile
- 16 wiper taps
- 3-wire up/down serial interface
- $V_{CC} = 2.7V$ and $5V$
- Active current $< 50\mu A$ max.
- Standby current $< 1\mu A$ max.
- $R_{TOTAL} = 10K\Omega$
- Packages: MSOP-8, SOIC

DESCRIPTION

The Xicor X9116 is a digitally controlled nonvolatile potentiometer designed to be used in trimmer applications. The pot consists of 15 equal resistor segments that connect to the wiper pin through programmable CMOS switches. The tap position is programmed through a 3-wire up/down serial port. The last position of the wiper is stored in a nonvolatile memory location which is recalled at the time of power up of the device.

The wiper moves through sequential tap positions with inputs on the serial port. A falling edge on INC (bar) causes the tap position to increment one position up or down based on whether the U/D (bar) pin is held high or low.

The X9116 can be used in many applications requiring a variable resistance. In many cases it can replace a mechanical trimmer and offers many advantages such as temperature and time stability as well as the reliability of a solid state solution.

BLOCK DIAGRAM

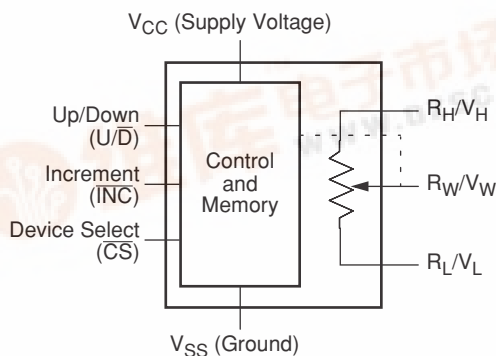

General

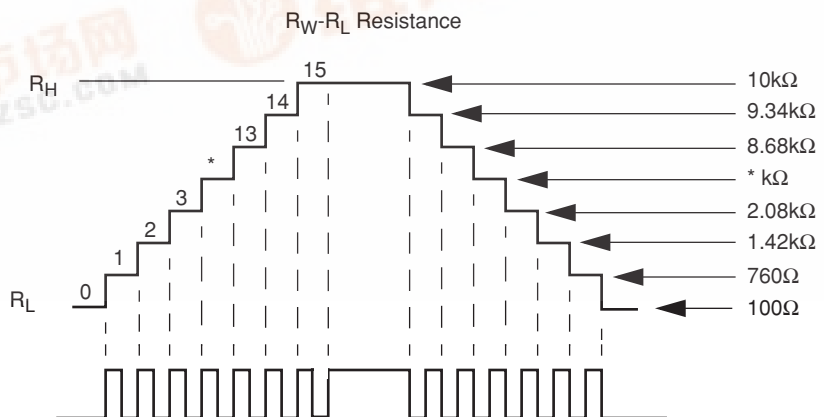

X9116

PIN DESCRIPTIONS

V_H/R_H and V_L/R_L

The high (V_H/R_H) and low (V_L/R_L) terminals of the X9116 are equivalent to the fixed terminals of a mechanical potentiometer. The minimum voltage is V_{SS} and the maximum is V_{CC} .

V_W/R_W

R_W/R_W is the wiper terminal and is equivalent to the movable terminal of a mechanical potentiometer. The position of the wiper within the array is determined by the control inputs. The wiper terminal series resistance is typically 200 Ω to 400 Ω depending upon V_{CC} .

Up/Down (U/\bar{D})

The U/\bar{D} input controls the direction of the wiper movement and whether the counter is incremented (up) or decremented (down).

Increment (\bar{INC})

The \bar{INC} input is negative-edge triggered. Toggling \bar{INC} will move the wiper and either increment or decrement the counter in the direction indicated by the logic level on the U/\bar{D} input.

Chip Select (\bar{CS})

The device is selected when the \bar{CS} input is LOW. The current counter value is stored in nonvolatile memory when \bar{CS} is returned HIGH while the \bar{INC} input is also HIGH. After the store operation is complete the X9116 will be placed in the low power standby mode until the device is selected once again.

PIN CONFIGURATION

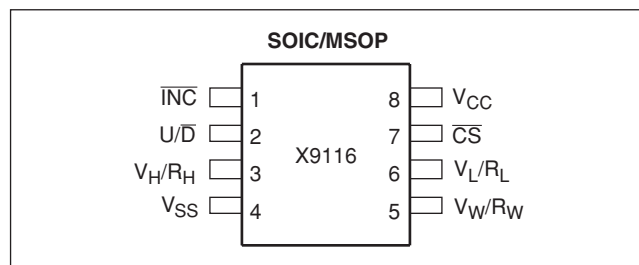

PIN NAMES

Symbol	Description
V_H/R_H	High Terminal
V_W/R_W	Wiper Terminal
V_L/R_L	Low Terminal
V_{SS}	Ground
V_{CC}	Supply Voltage
U/\bar{D}	Up/Down Control Input
\bar{INC}	Increment Control Input
\bar{CS}	Chip Select Input

PRINCIPLES OF OPERATION

There are three sections of the X9116: the input control, counter and decode section; the nonvolatile memory; and the resistor array. The input control section operates just like an up/down counter. The output of this counter is decoded to turn on a single electronic switch connecting a point on the resistor array to the wiper output. Under the proper conditions the contents of the counter can be stored in nonvolatile memory and retained for future use. The resistor array is comprised of 15 individual resistors connected in series. At either end of the array and between each resistor is an electronic switch that transfers the potential at that point to the wiper pin.

The wiper, when at either fixed terminal, acts like its mechanical equivalent and does not move beyond the last position. That is, the counter does not wrap around when clocked to either extreme.

The electronic switches on the device operate in a "make before break" mode when the wiper changes tap positions. If the wiper is moved several positions, multiple taps are connected to the wiper for t_{1W} (\bar{INC} to V_W change). The R_{TOTAL} value for the device can temporarily be reduced by a significant amount if the wiper is moved several positions.

When the device is powered-down, the last wiper position stored will be maintained in the nonvolatile memory. When power is restored, the contents of the memory are recalled and the wiper is set to the value last stored.

X9116

INSTRUCTIONS AND PROGRAMMING

The \overline{INC} , U/\overline{D} and \overline{CS} inputs control the movement of the wiper along the resistor array. With \overline{CS} set LOW, the device is selected and enabled to respond to the U/\overline{D} and \overline{INC} inputs. HIGH to LOW transitions on \overline{INC} will increment or decrement (depending on the state of the U/\overline{D} input) a four bit counter. The output of this counter is decoded to select one of 16 wiper positions along the resistive array.





The value of the counter is stored in nonvolatile memory whenever \overline{CS} transitions HIGH while the \overline{INC} input is also HIGH.

The system may select the X9116, move the wiper, and deselect the device without having to store the latest wiper position in nonvolatile memory. After the wiper movement is performed as described above and once the new position is reached, the system must keep \overline{INC} LOW while taking \overline{CS} HIGH. The new wiper position will be maintained until changed by the system or until a power-up/down cycle recalls the previously stored data.





This procedure allows the system to always power-up to a preset value stored in nonvolatile memory; then during system operation, minor adjustments could be made. The adjustments might be based on user preference, system parameter changes due to temperature drift, etc.

The state of U/\overline{D} may be changed while \overline{CS} remains LOW. This allows the host system to enable the device and then move the wiper up and down until the proper trim is attained.

MODE SELECTION

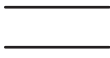
\overline{CS}	\overline{INC}	U/\overline{D}	Mode
L		H	Wiper Up
L		L	Wiper Down
	H	X	Store Wiper Position
H	X	X	Standby Current
	L	X	No Store, Return to Standby

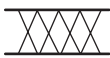
SYMBOL TABLE

WAVEFORM	INPUTS	OUTPUTS
	Must be steady	Will be steady
	May change from Low to High	Will change from Low to High
	May change from High to Low	Will change from High to Low
	Don't Care: Changes Allowed	Changing: State Not Known
	N/A	Center Line is High Impedance

X9116

ABSOLUTE MAXIMUM RATINGS

Temperature under bias-65°C to +135°C
 Storage temperature-65°C to +150°C
 Voltage on \overline{CS} , \overline{INC} , U/\overline{D} , V_H/R_H , V_L/R_L
 and V_{CC} with respect to V_{SS}-1V to +7V
 $\Delta V = |V_H/R_H - V_L/R_L|$ 5.5V
 Lead temperature (soldering 10 seconds).....300°C
 I_W (10 seconds) ± 10.0 mA

COMMENT

Stresses above those listed under “Absolute Maximum Ratings” may cause permanent damage to the device. This is a stress rating only; the functional operation of the device (at these or any other conditions above those listed in the operational sections of this specification) is not implied. Exposure to absolute maximum rating conditions for extended periods may affect device reliability.

RECOMMENDED OPERATING CONDITIONS

Temperature	Min.	Max.
Commercial	0°C	+70°C
Industrial	-40°C	+85°C

Supply Voltage (V_{CC})	Limits
X9116	5V $\pm 10\%$
X9116-2.7	2.7V to 5.5V

POTENTIOMETER CHARACTERISTICS (Over recommended operating conditions unless otherwise stated)

Symbol	Parameter	Limits				Test Conditions/Notes
		Min.	Typ.	Max.	Unit	
R_{TOTAL}	End to end resistance variation	-20		+20	%	
V_{VH}	V_H/R_H terminal voltage	V_{SS}		V_{CC}	V	$V_{SS} = 0V$
V_{VL}	V_L/R_L terminal voltage	V_{SS}		V_{CC}	V	$V_{SS} = 0V$
	Power rating			10	mW	$R_{TOTAL} = 10 K\Omega$
R_W	Wiper resistance		200	400	Ω	$I_W = 1mA, V_{CC} = 5V$
R_W	Wiper resistance		400	1000	Ω	$I_W = 1mA, V_{CC} = 2.7V$
I_W	Wiper current	-5.0		+5.0	mA	
	Noise		-120		dBV \sqrt{Hz}	Ref: 1kHz
	Resolution		6		%	
	Absolute linearity ⁽¹⁾	-1		+1	MI ⁽³⁾	$V_{w(n)(actual)} - V_{w(n)(expected)}$
	Relative linearity ⁽²⁾	-0.2		+0.2	MI ⁽³⁾	$V_{w(n+1)} - [V_{w(n)} + MI]$
	R_{TOTAL} temperature coefficient			± 300		ppm/°C
	Ratiometric temperature coefficient			± 20		ppm/°C
$C_H/C_L/C_W$	Potentiometer capacitances		10/10/25		pF	See Circuit #3

- Notes:** (1) Absolute linearity is utilized to determine actual wiper voltage versus expected voltage = $(V_{w(n)(actual)} - V_{w(n)(expected)}) = \pm 1$ MI Maximum.
 (2) Relative linearity is a measure of the error in step size between taps = $V_{w(n+1)} - [V_{w(n)} + MI] = \pm 0.2$ MI.
 (3) 1 MI = Minimum Increment = $R_{TOT}/15$.

X9116

D.C. OPERATING CHARACTERISTICS (Over recommended operating conditions unless otherwise specified)

Symbol	Parameter	Limits			Unit	Test Conditions
		Min.	Typ.(4)	Max.		
I_{CC1}	V_{CC} active current (Increment)			150	μA	$\overline{CS} = V_{IL}$, $U/\overline{D} = V_{IL}$ or V_{IH} and $\overline{INC} = 0.4V/2.4V$ @ max. t_{CYC}
I_{CC2}	V_{CC} active current (Store) (EEPROM Store)			400	μA	$\overline{CS} = V_{IH}$, $U/\overline{D} = V_{IL}$ or V_{IH} and $\overline{INC} = V_{IH}$ @ max. t_{WR}
I_{SB}	Standby supply current			1	μA	$\overline{CS} = V_{CC} - 0.3V$, U/\overline{D} and $\overline{INC} = V_{SS}$ or $V_{CC} - 0.3V$
I_{LI}	\overline{CS} , \overline{INC} , U/\overline{D} input leakage current			± 10	μA	$V_{IN} = V_{SS}$ to V_{CC}
V_{IH}	\overline{CS} , \overline{INC} , U/\overline{D} input HIGH voltage	2V		$V_{CC} + 0.5$	V	
V_{IL}	\overline{CS} , \overline{INC} , U/\overline{D} input LOW voltage	-0.5		0.8	V	
$C_{IN}^{(5)}$	\overline{CS} , \overline{INC} , U/\overline{D} input capacitance			10	pF	$V_{CC} = 5V$, $V_{IN} = V_{SS}$, $T_A = 25^\circ C$, $f = 1MHz$

Notes: (4) Typical values are for $T_A = 25^\circ C$ and nominal supply voltage.
 (5) This parameter is periodically sampled and not 100% tested.

ENDURANCE AND DATA RETENTION

Parameter	Min.	Unit
Minimum endurance	100,000	Data changes per bit
Data retention	100	Years

Test Circuit #1

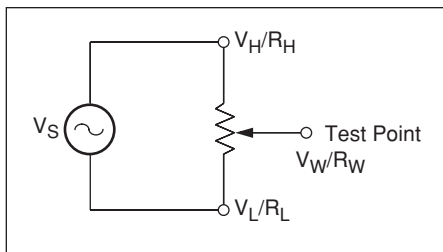

Test Circuit #2

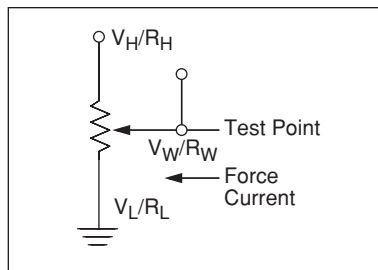

Circuit #3 SPICE Macro Model

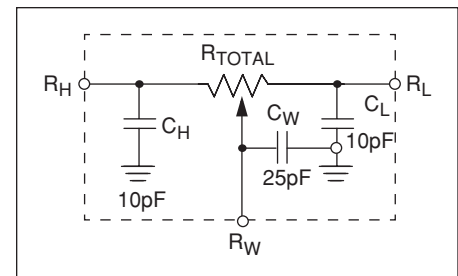

A.C. CONDITIONS OF TEST

Input pulse levels	0V to 3V
Input rise and fall times	10ns
Input reference levels	1.5V

X9116

A.C. OPERATING CHARACTERISTICS (Over recommended operating conditions unless otherwise specified)

Symbol	Parameter	Limits			Unit
		Min.	Typ. ⁽⁶⁾	Max.	
t_{CI}	\overline{CS} to \overline{INC} setup	100			ns
t_{ID}	\overline{INC} HIGH to U/\overline{D} change	100			ns
t_{DI}	U/\overline{D} to \overline{INC} setup	2.9			μ s
t_{iL}	\overline{INC} LOW period	1			μ s
t_{iH}	\overline{INC} HIGH period	1			μ s
t_{iC}	\overline{INC} inactive to \overline{CS} inactive	1			μ s
t_{CPH}	\overline{CS} deselect time (STORE)	10			ms
t_{iW}	\overline{INC} to V_w change		1	5	μ s
t_{CYC}	\overline{INC} cycle time	4			μ s
$t_R, t_F^{(7)}$	\overline{INC} input rise and fall time			500	μ s
$t_{PU}^{(7)}$	Power up to wiper stable			5	μ s
$t_R V_{CC}^{(7)}$	V_{CC} Power-up rate	15		50	mV/ μ s
t_{WR}	Store cycle		5	10	ms

POWER UP AND DOWN REQUIREMENTS

There are no restrictions on the power-up or power-down conditions of V_{CC} and the voltages applied to the potentiometer pins provided that V_{CC} is always more positive than or equal to V_H , V_L , and V_W , i.e., $V_{CC} \geq V_H, V_L, V_W$. The V_{CC} ramp rate spec is always in effect.

A.C. TIMING

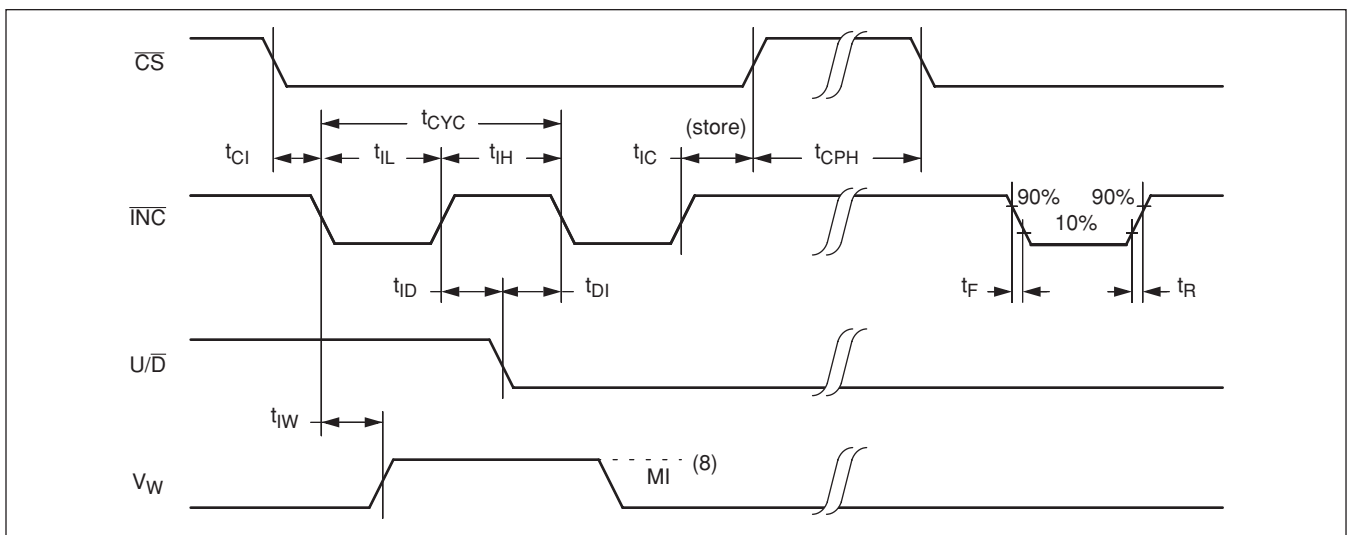

Notes: (6) Typical values are for $T_A = 25^\circ\text{C}$ and nominal supply voltage.

(7) This parameter is not 100% tested.

(8) MI in the A.C. timing diagram refers to the minimum incremental change in the V_w output due to a change in the wiper position.

Basic Configurations of Electronic Potentiometers

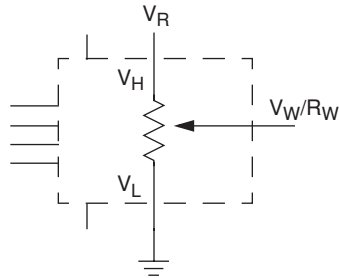

Three terminal potentiometer; variable voltage divider

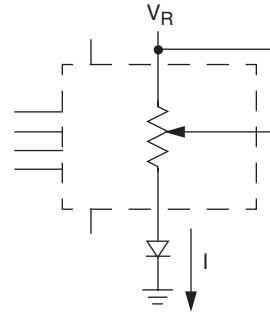

Two terminal variable resistor; variable current

Basic Circuits

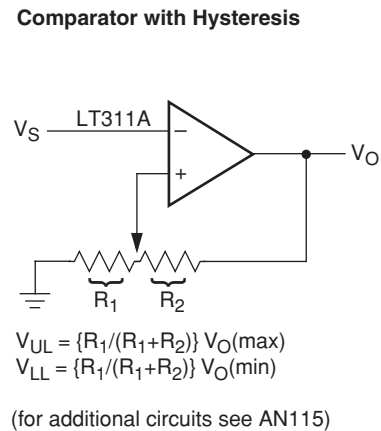
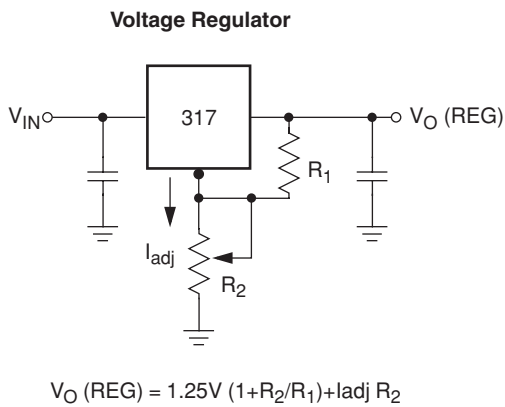
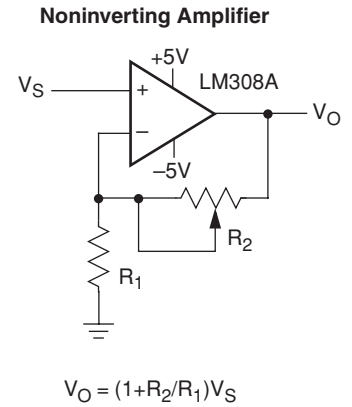
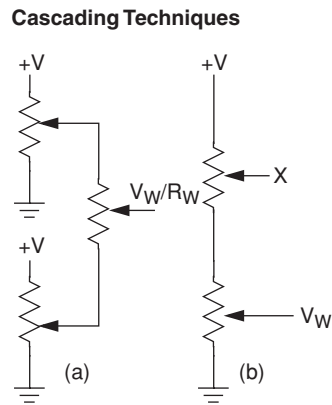
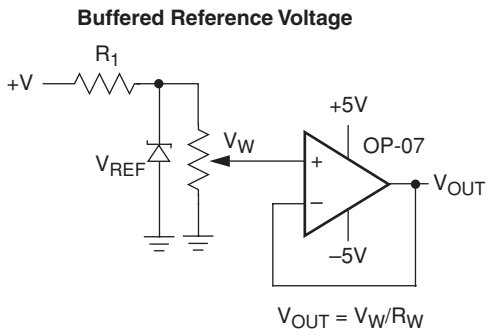

X9116

PACKAGING INFORMATION

8-Lead Miniature Small Outline Gull Wing Package Type M

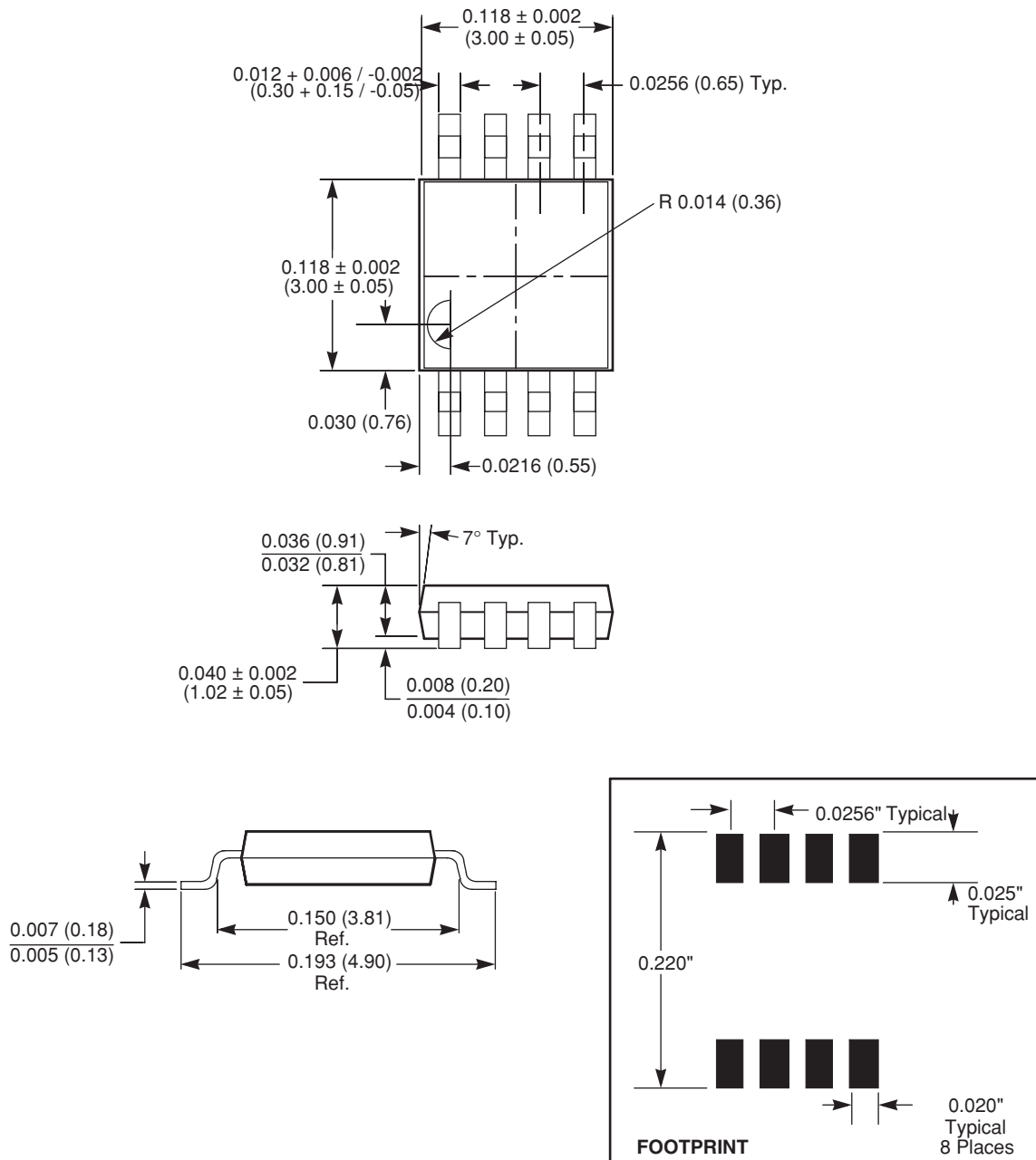

NOTE:

1. ALL DIMENSIONS IN INCHES AND (MILLIMETERS)

X9116

PACKAGING INFORMATION

8-Lead Miniature Small Outline Gull Wing Package Type M

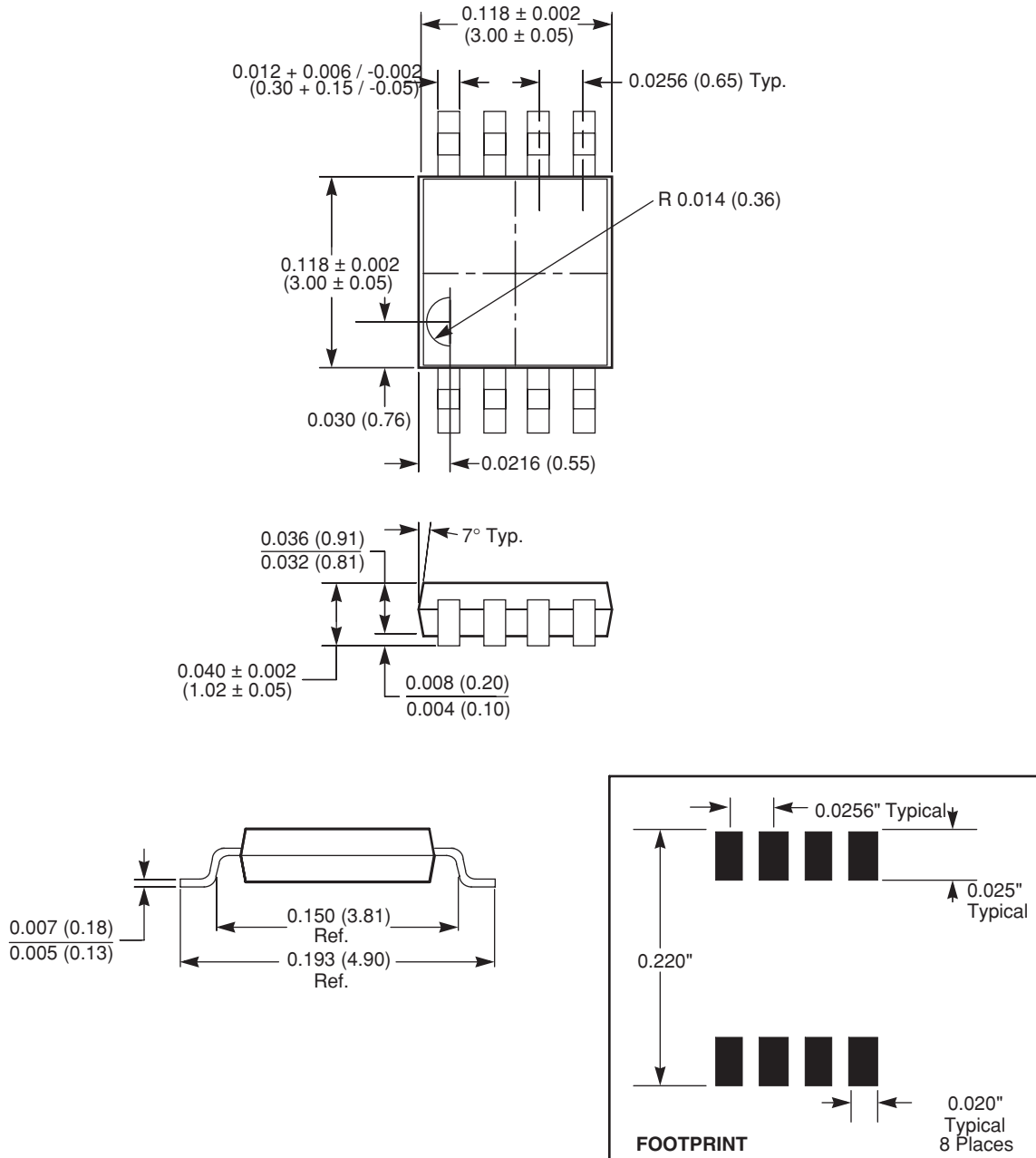

NOTE:

1. ALL DIMENSIONS IN INCHES AND (MILLIMETERS)

X9116

PACKAGING INFORMATION

8-Lead Plastic Small Outline Gull Wing Package Type S

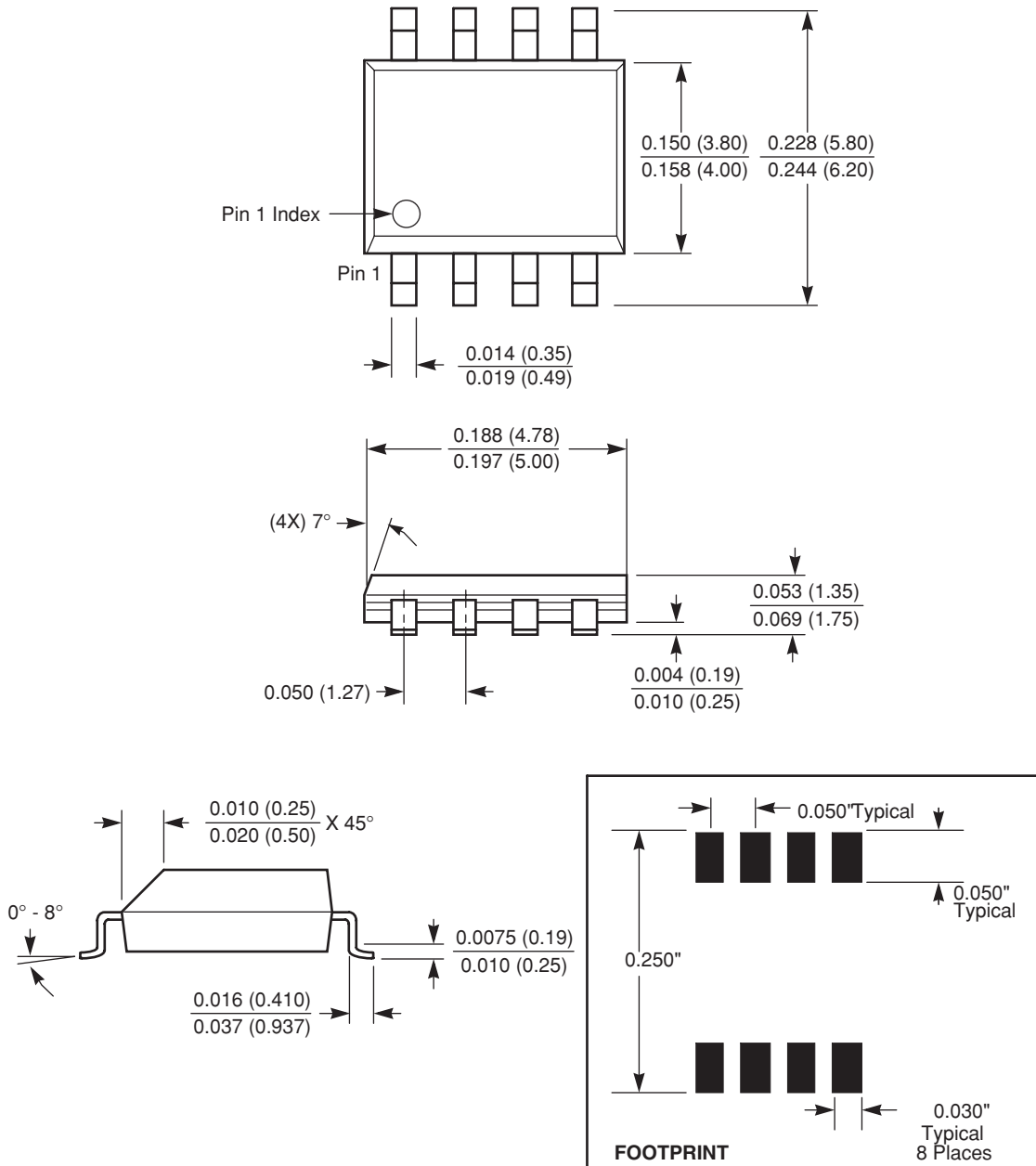

NOTE: ALL DIMENSIONS IN INCHES (IN PARENTHESES IN MILLIMETERS)

X9116

Ordering Information

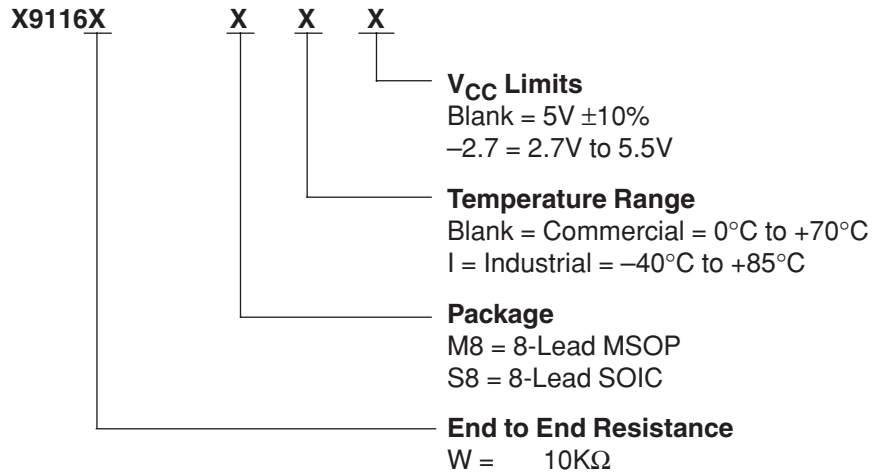

LIMITED WARRANTY

©Xicor, Inc. 2000 Patents Pending

Devices sold by Xicor, Inc. are covered by the warranty and patent indemnification provisions appearing in its Terms of Sale only. Xicor, Inc. makes no warranty, express, statutory, implied, or by description regarding the information set forth herein or regarding the freedom of the described devices from patent infringement. Xicor, Inc. makes no warranty of merchantability or fitness for any purpose. Xicor, Inc. reserves the right to discontinue production and change specifications and prices at any time and without notice.

Xicor, Inc. assumes no responsibility for the use of any circuitry other than circuitry embodied in a Xicor, Inc. product. No other circuits, patents, or licenses are implied.

TRADEMARK DISCLAIMER:

Xicor and the Xicor logo are registered trademarks of Xicor, Inc. AutoStore, Direct Write, Block Lock, SerialFlash, MPS, and XDCP are also trademarks of Xicor, Inc. All others belong to their respective owners.

U.S. PATENTS

Xicor products are covered by one or more of the following U.S. Patents: 4,326,134; 4,393,481; 4,404,475; 4,450,402; 4,486,769; 4,488,060; 4,520,461; 4,533,846; 4,599,706; 4,617,652; 4,668,932; 4,752,912; 4,829,482; 4,874,967; 4,883,976; 4,980,859; 5,012,132; 5,003,197; 5,023,694; 5,084,667; 5,153,880; 5,153,691; 5,161,137; 5,219,774; 5,270,927; 5,324,676; 5,434,396; 5,544,103; 5,587,573; 5,835,409; 5,977,585. Foreign patents and additional patents pending.

LIFE RELATED POLICY

In situations where semiconductor component failure may endanger life, system designers using this product should design the system with appropriate error detection and correction, redundancy and back-up features to prevent such an occurrence.

Xicor's products are not authorized for use in critical components in life support devices or systems.

1. Life support devices or systems are devices or systems which, (a) are intended for surgical implant into the body, or (b) support or sustain life, and whose failure to perform, when properly used in accordance with instructions for use provided in the labeling, can be reasonably expected to result in a significant injury to the user.
2. A critical component is any component of a life support device or system whose failure to perform can be reasonably expected to cause the failure of the life support device or system, or to affect its safety or effectiveness.