

Quad Digitally Controlled Potentiometer (XDCP™)

The X9241A integrates four digitally controlled potentiometers (XDCP) on a monolithic CMOS integrated microcircuit.

The digitally controlled potentiometer is implemented using 63 resistive elements in a series array. Between each element are tap points connected to the wiper terminal through switches. The position of the wiper on the array is controlled by the user through the 2-wire bus interface. Each potentiometer has associated with it a volatile Wiper Counter Register (WCR) and 4 nonvolatile Data Registers (DR0:DR3) that can be directly written to and read by the user. The contents of the WCR controls the position of the wiper on the resistor array through the switches. Power up recalls the contents of DR0 to the WCR.

The XDCP can be used as a three-terminal potentiometer or as a two-terminal variable resistor in a wide variety of applications including control, parameter adjustments, and signal processing.

Features

- Four potentiometers in one package
- 2-wire serial interface
- Register oriented format
 - Direct read/write/transfer of wiper positions
 - Store as many as four positions per potentiometer
- Terminal Voltages: +5V, -3.0V
- Cascade resistor arrays
- Low power CMOS
- High Reliability
 - Endurance—100,000 data changes per bit per register
 - Register data retention—100 years
- 16-bytes of nonvolatile memory
- 3 resistor array values
 - 2kΩ to 50kΩ mask programmable
 - Cascadable for values of 500Ω to 200kΩ
- Resolution: 64 taps each pot
- 20 Ld plastic DIP, 20 Ld TSSOP and 20 Ld SOIC packages
- Pb-free plus anneal available (RoHS compliant)

Block Diagram

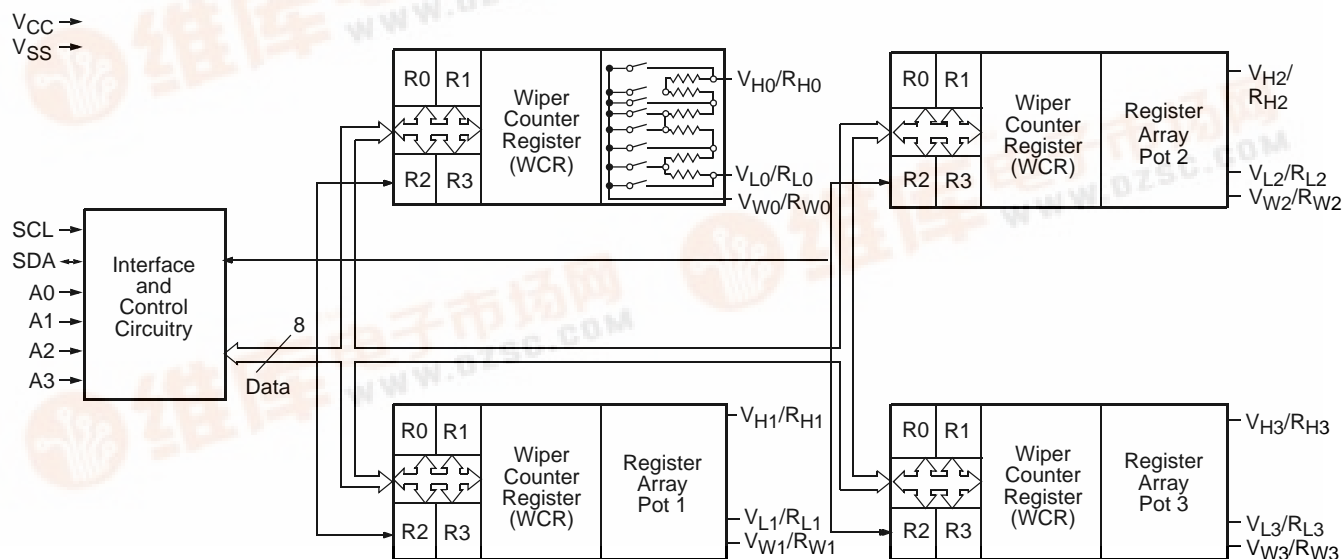

X9241A

Ordering Information

| PART NUMBER | PART MARKING | V _{CC} LIMITS (V) | POTENTIOMETER ORGANIZATION (K) | TEMP RANGE (°C) | PACKAGE |
|--------------------|--------------|----------------------------|--------------------------------|-----------------|-----------------------|
| X9241AMP | X9241AMP | 5 ±10% | 2/10/50 | 0 to 70 | 20 Ld PDIP |
| X9241AMPZ (Note) | X9241AMPZ | | | 0 to 70 | 20 Ld PDIP (Pb-free) |
| X9241AMPI | X9241AMPI | | | -40 to 85 | 20 Ld PDIP |
| X9241AMPIZ (Note) | X9241AMPIZ | | | -40 to 85 | 20 Ld PDIP (Pb-free) |
| X9241AMS* | X9241AMS | | | 0 to 70 | 20 Ld SOIC |
| X9241AMSZ* (Note) | X9241AMS Z | | | 0 to 70 | 20 Ld SOIC (Pb-free) |
| X9241AMSI* | X9241AMSI | | | -40 to 85 | 20 Ld SOIC |
| X9241AMSIZ* (Note) | X9241AMSI Z | | | -40 to 85 | 20 Ld SOIC (Pb-free) |
| X9241AMV* | X9241AMV | | | 0 to 70 | 20 Ld TSSOP |
| X9241AMVZ* (Note) | X9241AMV Z | | | 0 to 70 | 20 Ld TSSOP (Pb-free) |
| X9241AMVI* | X9241AMVI | | | -40 to 85 | 20 Ld TSSOP |
| X9241AMVIZ* (Note) | X9241AMVI Z | | | -40 to 85 | 20 Ld TSSOP (Pb-free) |
| X9241AWP | X9241AWP | 10 | 10 | 0 to 70 | 20 Ld PDIP |
| X9241AWPZ (Note) | | | | 0 to 70 | 20 Ld PDIP (Pb-free) |
| X9241AWPI | X9241AWPI | | | -40 to 85 | 20 Ld PDIP |
| X9241AWPIZ (Note) | X9241AWPI Z | | | -40 to 85 | 20 Ld PDIP (Pb-free) |
| X9241AWS* | X9241AWS | | | 0 to 70 | 20 Ld SOIC |
| X9241AWSZ* (Note) | X9241AWS Z | | | 0 to 70 | 20 Ld SOIC (Pb-free) |
| X9241AWSI* | X9241AWSI | | | -40 to 85 | 20 Ld SOIC |
| X9241AWSIZ* (Note) | X9241AWSI Z | | | -40 to 85 | 20 Ld SOIC (Pb-free) |
| X9241AWV* | X9241AWV | | | 0 to 70 | 20 Ld TSSOP |
| X9241AWVZ* (Note) | X9241AWVZ | | | 0 to 70 | 20 Ld TSSOP (Pb-free) |
| X9241AWVI* | X9241AWVI | | | -40 to 85 | 20 Ld TSSOP |
| X9241AWVIZ* (Note) | X9241AWVI Z | | | -40 to 85 | 20 Ld TSSOP (Pb-free) |
| X9241AYP | X9241AYP | 2 | 2 | 0 to 70 | 20 Ld PDIP |
| X9241AYPZ (Note) | X9241AYP Z | | | 0 to 70 | 20 Ld PDIP (Pb-free) |
| X9241AYPI | X9241AYPI | | | -40 to 85 | 20 Ld PDIP |
| X9241AYPIZ (Note) | X9241AYPI Z | | | -40 to 85 | 20 Ld PDIP (Pb-free) |
| X9241AYS* | X9241AYS | | | 0 to 70 | 20 Ld SOIC |
| X9241AYSZ* (Note) | X9241AYS Z | | | 0 to 70 | 20 Ld SOIC (Pb-free) |
| X9241AYSI* | X9241AYSI | | | -40 to 85 | 20 Ld SOIC |
| X9241AYSIZ* (Note) | | | | -40 to 85 | 20 Ld SOIC (Pb-free) |
| X9241AYV* | X9241AYV | | | 0 to 70 | 20 Ld TSSOP |
| X9241AYVZ* (Note) | X9241AYV Z | | | 0 to 70 | 20 Ld TSSOP (Pb-free) |
| X9241AYVI* | X9241AYVI | | | -40 to 85 | 20 Ld TSSOP |
| X9241AYVIZ* (Note) | X9241AYVI Z | | | -40 to 85 | 20 Ld TSSOP (Pb-free) |

X9241A

Ordering Information (Continued)

| PART NUMBER | PART MARKING | V _{CC} LIMITS (V) | POTENTIOMETER ORGANIZATION (K) | TEMP RANGE (°C) | PACKAGE |
|--------------------|--------------|----------------------------|--------------------------------|-----------------|-----------------------|
| X9241AUP | X9241AUP | 5 ±10% | 50 | 0 to 70 | 20 Ld PDIP |
| X9241AUPZ (Note) | X9241AUP Z | | | 0 to 70 | 20 Ld PDIP (Pb-free) |
| X9241AUPI | X9241AUPI | | | -40 to 85 | 20 Ld PDIP |
| X9241AUIPZ (Note) | X9241AUIP Z | | | -40 to 85 | 20 Ld PDIP (Pb-free) |
| X9241AUS* | X9241AUS | | | 0 to 70 | 20 Ld SOIC |
| X9241AUSZ* (Note) | X9241AUS Z | | | 0 to 70 | 20 Ld SOIC (Pb-free) |
| X9241AUSI* | X9241AUSI | | | -40 to 85 | 20 Ld SOIC |
| X9241AUSIZ* (Note) | X9241AUSI Z | | | -40 to 85 | 20 Ld SOIC (Pb-free) |
| X9241AUV* | X9241AUV | | | 0 to 70 | 20 Ld TSSOP |
| X9241AUVZ* (Note) | X9241AUV Z | | | 0 to 70 | 20 Ld TSSOP (Pb-free) |
| X9241AUVI* | X9241AUVI | | | -40 to 85 | 20 Ld TSSOP |
| X9241AUVIZ* (Note) | X9241AUVI Z | | | -40 to 85 | 20 Ld TSSOP (Pb-free) |

*Add "T1" suffix for tape and reel.

NOTE: Intersil Pb-free plus anneal products employ special Pb-free material sets; molding compounds/die attach materials and 100% matte tin plate termination finish, which are RoHS compliant and compatible with both SnPb and Pb-free soldering operations. Intersil Pb-free products are MSL classified at Pb-free peak reflow temperatures that meet or exceed the Pb-free requirements of IPC/JEDEC J STD-020.

Pin Descriptions

Host Interface Pins

Serial Clock (SCL)

The SCL input is used to clock data into and out of the X9241A.

Serial Data (SDA)

SDA is a bidirectional pin used to transfer data into and out of the device. It is an open drain output and may be wire-ORed with any number of open drain or open collector outputs. An open drain output requires the use of a pull-up resistor. For selecting typical values, refer to the guidelines for calculating typical values on the bus pull-up resistors graph.

Address

The Address inputs are used to set the least significant 4 bits of the 8-bit slave address. A match in the slave address serial data stream must be made with the Address input in order to initiate communication with the X9241A.

Potentiometer Pins

V_H/R_H (V_{H0}/R_{H0}—V_{H3}/R_{H3}), V_L/R_L (V_{L0}/R_{L0}—V_{L3}/R_{L3})

The R_H and R_L inputs are equivalent to the terminal connections on either end of a mechanical potentiometer.

V_W/R_W (V_{W0}/R_{W0}—V_{W3}/R_{W3})

The wiper outputs are equivalent to the wiper output of a mechanical potentiometer.

Pin Configuration

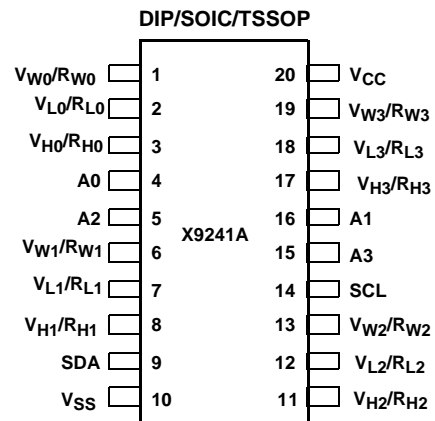

Pin Names

| SYMBOL | DESCRIPTION |
|--|--|
| SCL | Serial Clock |
| SDA | Serial Data |
| A0–A3 | Address |
| V _{H0} /R _{H0} –V _{H3} /R _{H3} , V _{L0} /R _{L0} –V _{L3} /R _{L3} | Potentiometer Pins (terminal equivalent) |
| V _{W0} /R _{W0} –V _{W3} /R _{W3} | Potentiometer Pins (wiper equivalent) |

X9241A

Principles of Operation

The X9241A is a highly integrated microcircuit incorporating four resistor arrays, their associated registers and counters and the serial interface logic providing direct communication between the host and the XDCP potentiometers.

Serial Interface

The X9241A supports a bidirectional bus oriented protocol. The protocol defines any device that sends data onto the bus as a transmitter and the receiving device as the receiver. The device controlling the transfer is a master and the device being controlled is the slave. The master will always initiate data transfers and provide the clock for both transmit and receive operations. Therefore, the X9241A will be considered a slave device in all applications.

Clock and Data Conventions

Data states on the SDA line can change only during SCL LOW periods (t_{LOW}). SDA state changes during SCL HIGH are reserved for indicating start and stop conditions.

Start Condition

All commands to the X9241A are preceded by the start condition, which is a HIGH to LOW transition of SDA while SCL is HIGH (t_{HIGH}). The X9241A continuously monitors the SDA and SCL lines for the start condition and will not respond to any command until this condition is met.

Stop Condition

All communications must be terminated by a stop condition, which is a LOW to HIGH transition of SDA while SCL is HIGH.

Acknowledge

Acknowledge is a software convention used to provide a positive handshake between the master and slave devices on the bus to indicate the successful receipt of data. The transmitting device, either the master or the slave, will release the SDA bus after transmitting eight bits. The master generates a ninth clock cycle and during this period the receiver pulls the SDA line LOW to acknowledge that it successfully received the eight bits of data. See Figure 7.

The X9241A will respond with an acknowledge after recognition of a start condition and its slave address and once again after successful receipt of the command byte. If the command is followed by a data byte the X9241A will respond with a final acknowledge.

Array Description

The X9241A is comprised of four resistor arrays. Each array contains 63 discrete resistive segments that are connected in series. The physical ends of each array are equivalent to the fixed terminals of a mechanical potentiometer (V_H/R_H and V_L/R_L inputs).

At both ends of each array and between each resistor segment is a FET switch connected to the wiper (V_W/R_W) output. Within each individual array only one switch may be turned on at a time. These switches are controlled by the Wiper Counter Register (WCR). The six least significant bits of the WCR are decoded to select, and enable, one of sixty-four switches.

The WCR may be written directly, or it can be changed by transferring the contents of one of four associated Data Registers into the WCR. These Data Registers and the WCR can be read and written by the host system.

Device Addressing

Following a start condition the master must output the address of the slave it is accessing. The most significant four bits of the slave address are the device type identifier (refer to Figure 1 below). For the X9241A this is fixed as 0101[B].

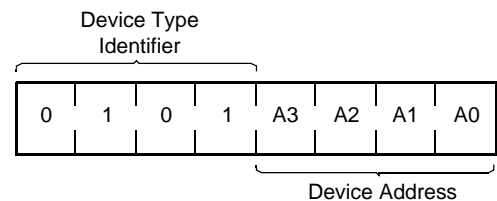

FIGURE 1. SLAVE ADDRESS

The next four bits of the slave address are the device address. The physical device address is defined by the state of the A0-A3 inputs. The X9241A compares the serial data stream with the address input state; a successful compare of all four address bits is required for the X9241A to respond with an acknowledge.

Acknowledge Polling

The disabling of the inputs, during the internal nonvolatile write operation, can be used to take advantage of the typical 5ms EEPROM write cycle time. Once the stop condition is issued to indicate the end of the nonvolatile write command the X9241A initiates the internal write cycle. ACK polling can be initiated immediately. This involves issuing the start condition followed by the device slave address. If the X9241A is still busy with the write operation no ACK will be returned. If the X9241A has completed the write operation an ACK will be returned and the master can then proceed with the next operation.

X9241A

Flow 1. ACK Polling Sequence

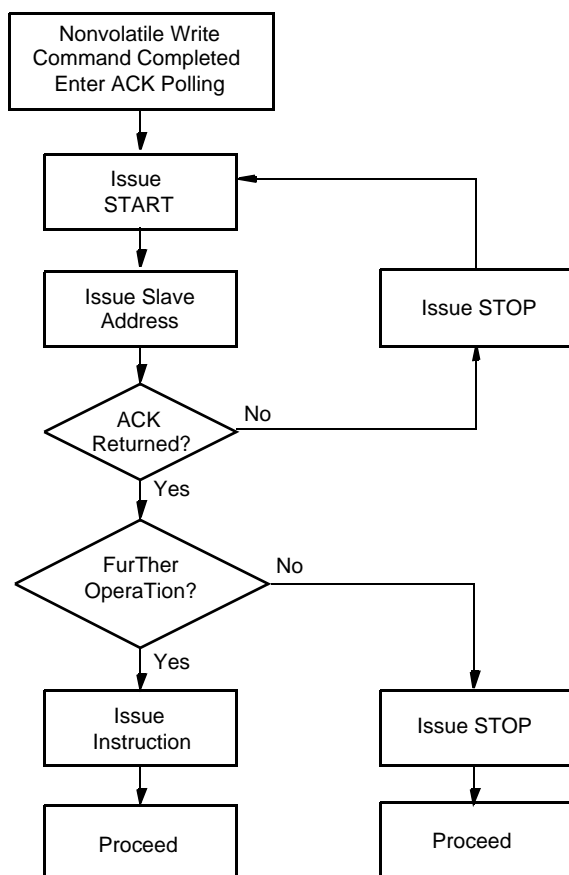

Instruction Structure

The next byte sent to the X9241A contains the instruction and register pointer information. The four most significant bits are the instruction. The next four bits point to one of four pots and when applicable they point to one of four associated registers. The format is shown below in Figure 2.

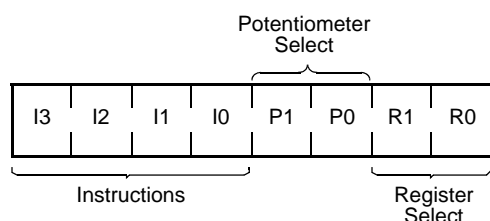

FIGURE 2. INSTRUCTION BYTE FORMAT

The four high order bits define the instruction. The next two bits (P1 and P0) select which one of the four potentiometers is to be affected by the instruction. The last two bits (R1 and R0) select one of the four registers that is to be acted upon when a register oriented instruction is issued.

Four of the nine instructions end with the transmission of the instruction byte. The basic sequence is illustrated in Figure 3. These two-byte instructions exchange data between the WCR and one of the data registers. A transfer from a Data Register to a WCR is essentially a write to a static RAM. The response of the wiper to this action will be delayed t_{STPWV} . A transfer from WCR current wiper position, to a Data Register is a write to nonvolatile memory and takes a minimum of t_{WR} to complete. The transfer can occur between one of the four potentiometers and one of its associated registers; or it may occur globally, wherein the transfer occurs between all four of the potentiometers and one of their associated registers.

Four instructions require a three-byte sequence to complete. These instructions transfer data between the host and the X9241A; either between the host and one of the Data Registers or directly between the host and the WCR. These instructions are: Read WCR, read the current wiper position of the selected pot; Write WCR, change current wiper position of the selected pot; Read Data Register, read the contents of the selected nonvolatile register; Write Data Register, write a new value to the selected Data Register. The sequence of operations is shown in Figure 4.

The Increment/Decrement command is different from the other commands. Once the command is issued and the X9241A has responded with an acknowledge, the master can clock the selected wiper up and/or down in one segment steps; thereby, providing a fine tuning capability to the host. For each SCL clock pulse (t_{HIGH}) while SDA is HIGH, the selected wiper will move one resistor segment towards the V_H/R_H terminal. Similarly, for each SCL clock pulse while SDA is LOW, the selected wiper will move one resistor segment towards the V_L/R_L terminal. A detailed illustration of the sequence and timing for this operation are shown in Figures 5 and 6 respectively.

X9241A

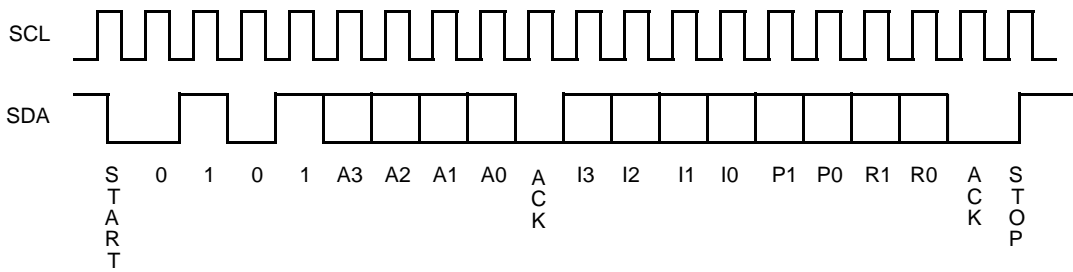

FIGURE 3. TWO-BYTE INSTRUCTION SEQUENCE

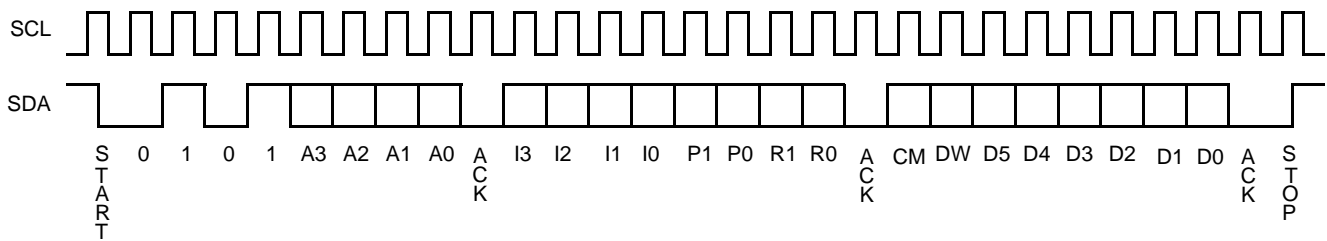

FIGURE 4. THREE-BYTE INSTRUCTION SEQUENCE

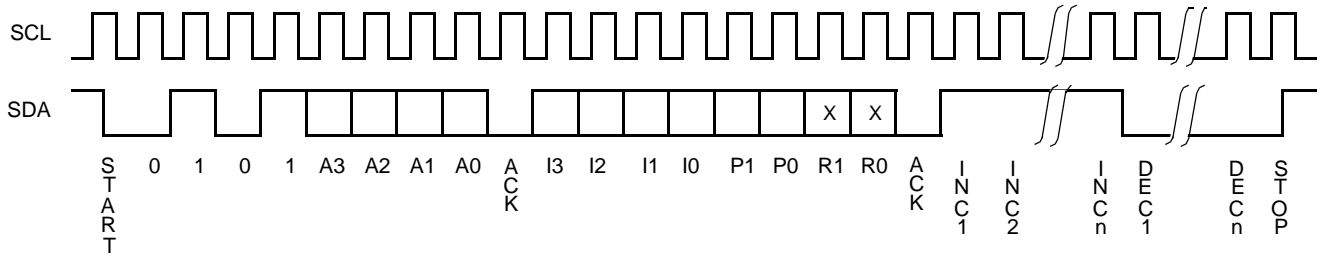

FIGURE 5. INCREMENT/DECREMENT INSTRUCTION SEQUENCE

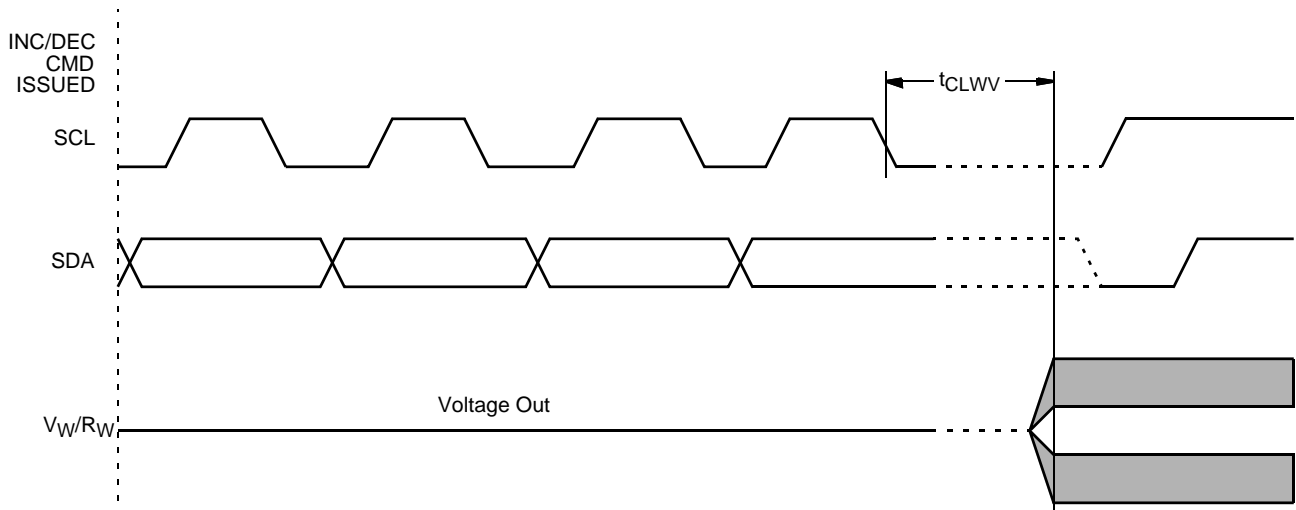

FIGURE 6. INCREMENT/DECREMENT TIMING LIMITS

X9241A

TABLE 1. INSTRUCTION SET

| INSTRUCTION | INSTRUCTION FORMAT | | | | | | | | OPERATION |
|---------------------------------|--------------------|----------------|----------------|----------------|---------------------|----------------|-------------------|----------------|---|
| | I ₃ | I ₂ | I ₁ | I ₀ | P ₁ | P ₀ | R ₁ | R ₀ | |
| Read WCR | 1 | 0 | 0 | 1 | 1/0 ⁽¹⁰⁾ | 1/0 | X ⁽¹¹⁾ | X | Read the contents of the Wiper Counter Register pointed to by P ₁ - P ₀ |
| Write WCR | 1 | 0 | 1 | 0 | 1/0 | 1/0 | X | X | Write new value to the Wiper Counter Register pointed to by P ₁ - P ₀ |
| Read Data Register | 1 | 0 | 1 | 1 | 1/0 | 1/0 | 1/0 | 1/0 | Read the contents of the Register pointed to by P ₁ - P ₀ and R ₁ - R ₀ |
| Write Data Register | 1 | 1 | 0 | 0 | 1/0 | 1/0 | 1/0 | 1/0 | Write new value to the Register pointed to by P ₁ - P ₀ and R ₁ - R ₀ |
| XFR Data Register to WCR | 1 | 1 | 0 | 1 | 1/0 | 1/0 | 1/0 | 1/0 | Transfer the contents of the Register pointed to by P ₁ - P ₀ and R ₁ - R ₀ to its associated WCR |
| XFR WCR to Data Register | 1 | 1 | 1 | 0 | 1/0 | 1/0 | 1/0 | 1/0 | Transfer the contents of the WCR pointed to by P ₁ - P ₀ to the Register pointed to by R ₁ - R ₀ |
| Global XFR Data Register to WCR | 0 | 0 | 0 | 1 | X | X | 1/0 | 1/0 | Transfer the contents of the Data Registers pointed to by R ₁ - R ₀ of all four pots to their respective WCR |
| Global XFR WCR to Data Register | 1 | 0 | 0 | 0 | X | X | 1/0 | 1/0 | Transfer the contents of all WCRs to their respective data Registers pointed to by R ₁ - R ₀ of all four pots |
| Increment/Decrement Wiper | 0 | 0 | 1 | 0 | 1/0 | 1/0 | X | X | Enable Increment/decrement of the WCR pointed to by P ₁ - P ₀ |

Notes: (10) 1/0 = data is one or zero

(11) X = Not applicable or don't care; that is, a data register is not involved in the operation and need not be addressed (typical)

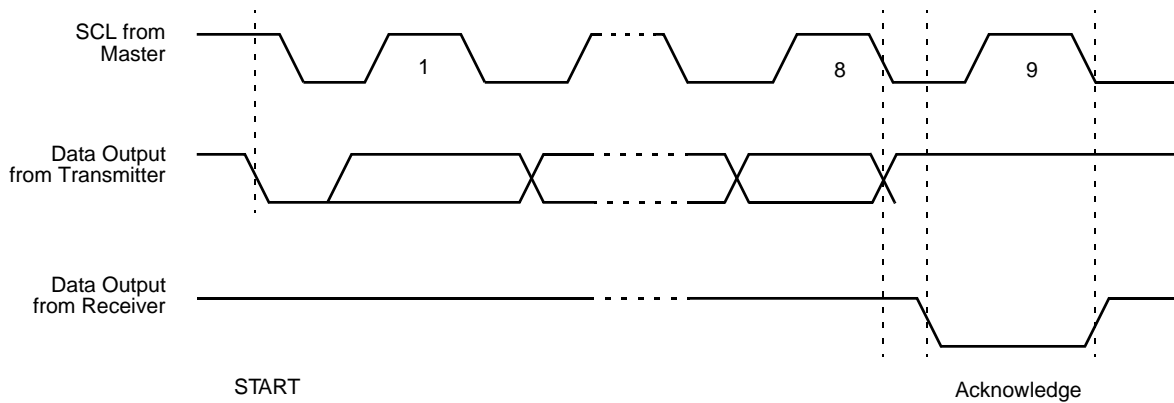

FIGURE 7. ACKNOWLEDGE RESPONSE FROM RECEIVER

X9241A

Detailed Operation

All four XDCP potentiometers share the serial interface and share a common architecture. Each potentiometer is comprised of a resistor array, a Wiper Counter Register and four Data Registers. A detailed discussion of the register organization and array operation follows.

Wiper Counter Register

The X9241A contains four volatile Wiper Counter Registers (WCR), one for each XDCP potentiometer. The WCR can be envisioned as a 6-bit parallel and serial load counter with its outputs decoded to select one of sixty-four switches along its resistor array. The contents of the WCR can be altered in four ways: it may be written directly by the host via the Write WCR instruction (serial load); it may be written indirectly by transferring the contents of one of four associated Data Registers via the XFR Data Register instruction (parallel load); it can be modified one step at a time by the increment/decrement instruction; finally, it is loaded with the contents of its Data Register zero (DR0) upon power-up.

The WCR is a volatile register; that is, its contents are lost when the X9241A is powered-down. Although the register is automatically loaded with the value in DR0 upon power-up, it should be noted this may be different from the value present at power-down.

Data Registers

Each potentiometer has four nonvolatile Data Registers. These can be read or written directly by the host and data can be transferred between any of the four Data Registers and the WCR. It should be noted all operations changing data in one of these registers is a nonvolatile operation and will take a maximum of 10ms.

If the application does not require storage of multiple settings for the potentiometer, these registers can be used as regular memory locations that could possibly store system parameters or user preference data.

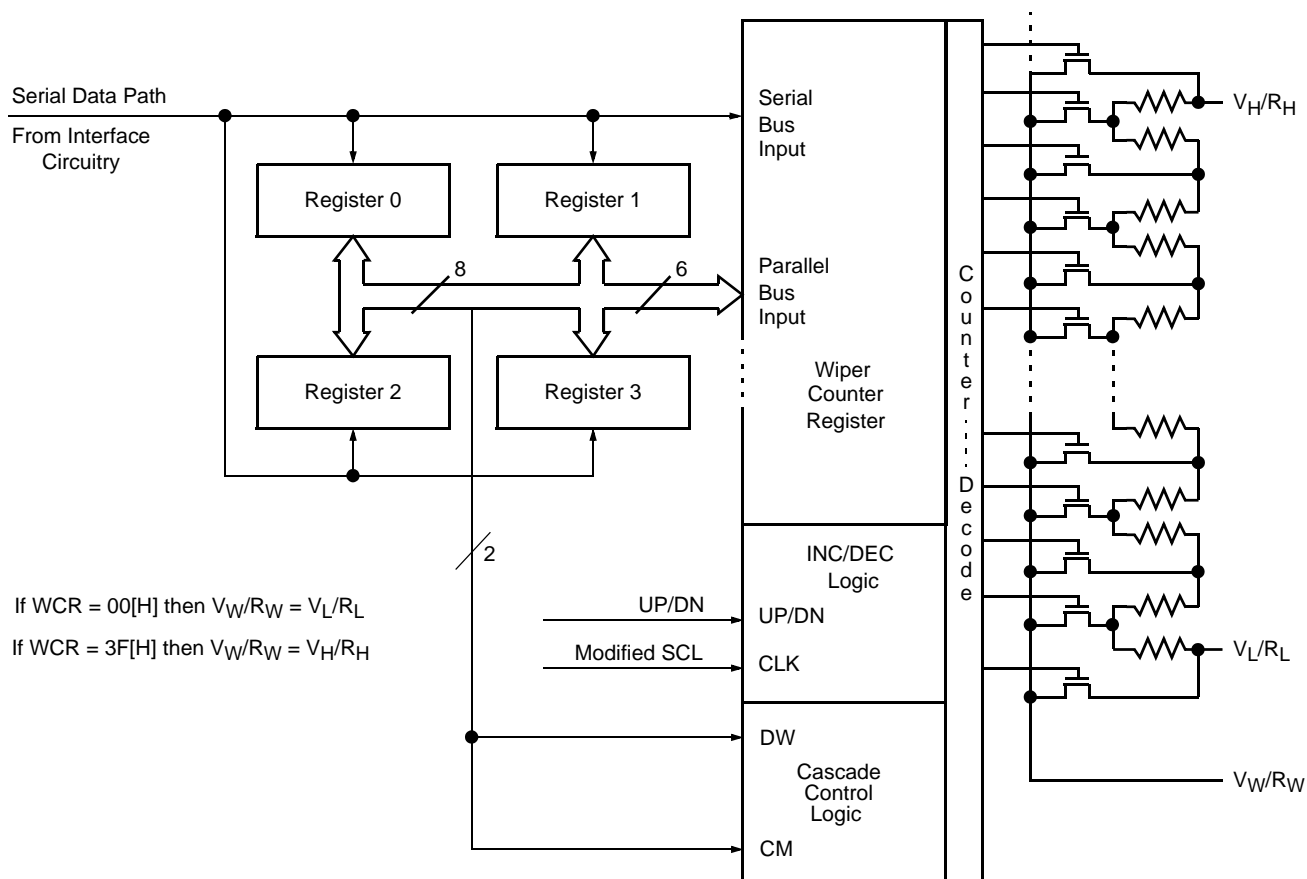

FIGURE 8. DETAILED POTENTIOMETER BLOCK DIAGRAM

X9241A

Cascade Mode

The X9241A provides a mechanism for cascading the arrays. That is, the sixty-three resistor elements of one array may be cascaded (linked) with the resistor elements of an adjacent array. The V_L/R_L of the higher order array must be connected to the V_H/R_H of the lower order array (See Figure 9).

Cascade Control Bits

The data byte, for the three-byte commands, contains 6 bits (LSBs) for defining the wiper position plus two high order bits, CM (Cascade Mode) and DW (Disable Wiper, normal operation).

The state of the CM bit (bit 7 of WCR) enables or disables cascade mode. When the CM bit of the WCR is set to "0" the potentiometer is in the normal operation mode. When the CM bit of the WCR is set to "1" the potentiometer is cascaded with its adjacent higher order potentiometer. For example; if bit 7 of WCR2 is set to "1", pot 2 will be cascaded to pot 3.

The state of DW enables or disables the wiper. When the DW bit of the WCR is set to "0" the wiper is enabled; when

set to "1" the wiper is disabled. If the wiper is disabled, the wiper terminal will be electrically isolated and float.

When operating in cascade mode V_H/R_H , V_L/R_L and the wiper terminals of the cascaded arrays must be electrically connected externally. All but one of the wipers must be disabled. The user can alter the wiper position by writing directly to the WCR or indirectly by transferring the contents of the Data Registers to the WCR or by using the Increment/Decrement command.

When using the Increment/Decrement command the wiper position will automatically transition between arrays. The current position of the wiper can be determined by reading the WCR registers; if the DW bit is "0", the wiper in that array is active. If the current wiper position is to be maintained on power-down a global XFR WCR to Data Register command must be issued to store the position in NV memory before power-down.

It is possible to connect three or all four potentiometers in cascade mode. It is also possible to connect POT 3 to POT 0 as a cascade. The requirements for external connections of V_L/R_L , V_H/R_H and the wipers are the same in these cases.

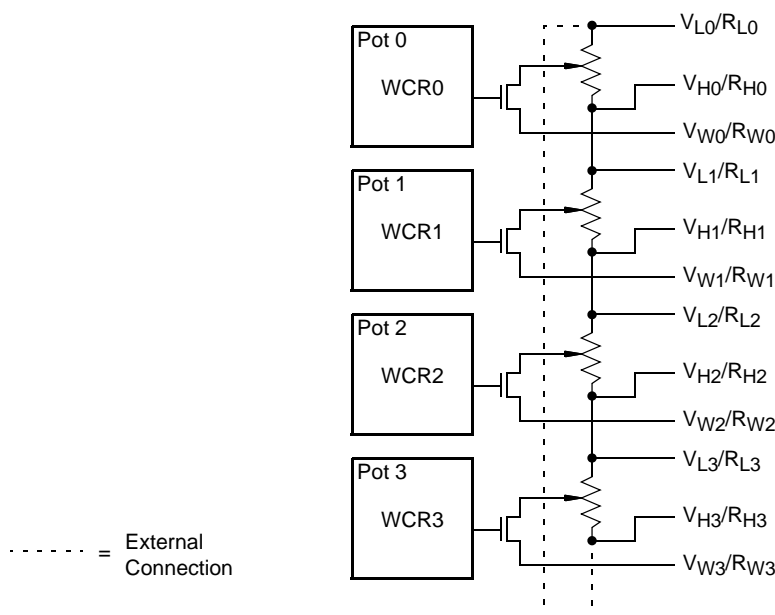

FIGURE 9. CASCADING ARRAYS

X9241A

Absolute Maximum Ratings

| | |
|--|---------------|
| Temperature under bias | -65 to +135°C |
| Storage temperature | -65 to +150°C |
| Voltage on SCK, SCL or any address input with respect to V_{SS} | -1V to +7V |
| Voltage on any V_H/R_H , V_W/R_W or V_L/R_L referenced to V_{SS} | +6V/-4V |
| $\Delta V = V_H/R_H - V_L/R_L $ | 10V |
| Lead temperature (soldering, 10 seconds) | 300°C |
| I_W (10 seconds) | ±6mA |

Recommended Operating Conditions

| | |
|------------------------------------|----------------|
| Temperature (Commercial) | 0°C to +70°C |
| Temperature (Industrial) | -40°C to +85°C |
| Supply Voltage (V_{CC}) Limits | |
| X9241A | 5V ± 10% |

CAUTION: Stresses above those listed under "Absolute Maximum Ratings" may cause permanent damage to the device. This is a stress rating only; the functional operation of the device (at these or any other conditions above those listed in the operational sections of this specification) is not implied. Exposure to absolute maximum rating conditions for extended periods may affect device reliability.

Analog Specifications (Over recommended operating conditions unless otherwise stated.)

| SYMBOL | PARAMETER | TEST CONDITION | LIMITS | | | UNIT |
|---------------|---|---|--------|----------|------|-------------------|
| | | | MIN | TYP | MAX | |
| R_{TOTAL} | End to end resistance | | -20 | | +20 | % |
| | Power rating | 25°C, each pot | | | 50 | mW |
| I_W | Wiper current | See Note 7, 8 | | | | mA |
| R_W | Wiper resistance | Wiper Current = ± 1mA (Note 7) | | 40 | 130 | Ω |
| V_{TERM} | Voltage on any V_H/R_H , V_W/R_W or V_L/R_L Pin | | -3.0 | | +5 | V |
| | Noise | Ref: 1kHz See Note 5 | | ≤120 | | dBV |
| | Resolution ⁽⁴⁾ | See Note 5 | | 1.6 | 0.4 | % |
| | Absolute linearity ⁽¹⁾ | $R_{W(n)(actual)} - R_{W(n)(expected)}$ | | | ±1 | MI ⁽³⁾ |
| | Relative linearity ⁽²⁾ | $R_{W(n+1)} - [R_{W(n)} + MI]$ | | | ±0.2 | MI ⁽³⁾ |
| | Temperature Coefficient of R_{TOTAL} | See Note 5 | | ±300 | | ppm/°C |
| | Ratiometric temperature coefficient | See Note 5 | | | ±20 | ppm/C |
| $C_H/C_L/C_W$ | Potentiometer capacitances | See Circuit #3 and Note 5 | | 15/15/25 | | pF |
| I_{AL} | R_H , R_I , R_W leakage current | $V_{IN} = V_{TERM}$. Device is in stand-by mode. | | 0.1 | 1 | μA |

DC Electrical Specifications (Over recommended operating conditions unless otherwise stated.)

| SYMBOL | PARAMETER | TEST CONDITION | LIMITS | | | UNIT |
|----------|----------------------------|--|--------|-----|--------------|------|
| | | | MIN | TYP | MAX | |
| I_{CC} | Supply current (active) | $f_{SCL} = 100kHz$, SDA = Open, Other Inputs = V_{SS} | | | 3 | mA |
| I_{SB} | V_{CC} current (standby) | SCL = SDA = V_{CC} , Addr. = V_{SS} | | 200 | 500 | μA |
| I_{LI} | Input leakage current | $V_{IN} = V_{SS}$ to V_{CC} | | | 10 | μA |
| I_{LO} | Output leakage current | $V_{OUT} = V_{SS}$ to V_{CC} | | | 10 | μA |
| V_{IH} | Input HIGH voltage | | 2 | | $V_{CC} + 1$ | V |
| V_{IL} | Input LOW voltage | | -1 | | 0.8 | V |
| V_{OL} | Output LOW voltage | $I_{OL} = 3mA$ | | | 0.4 | V |

- Notes:**
- (1) Absolute Linearity is utilized to determine actual wiper voltage versus expected voltage as determined by wiper position when used as a potentiometer.
 - (2) Relative Linearity is utilized to determine the actual change in voltage between two successive tap positions when used as a potentiometer. It is a measure of the error in step size.
 - (3) MI = $RTOT/63$ or $(R_H - R_L)/63$, single pot
 - (4) Max. = all four arrays cascaded together, Typical = individual array resolutions.

X9241A

Endurance and Data Retention

| PARAMETER | MIN | UNIT |
|-------------------|---------|-----------------------------------|
| Minimum endurance | 100,000 | Data changes per bit per register |
| Data retention | 100 | Years |

Capacitance

| SYMBOL | PARAMETER | TEST CONDITION | MAX | UNIT |
|-----------------|--|----------------|-----|------|
| $C_{I/O}^{(5)}$ | Input/output capacitance (SDA) | $V_{I/O} = 0V$ | 19 | pF |
| $C_{IN}^{(5)}$ | Input capacitance (A0, A1, A2, A3 and SCL) | $V_{IN} = 0V$ | 12 | pF |

Power-up Timing

| SYMBOL | PARAMETER | MIN | TYP | MAX | UNIT |
|-----------------|---|-----|-----|-----|--------|
| $t_{PUR}^{(6)}$ | Power-up to initiation of read operation | | | 1 | ms |
| $t_{PUW}^{(6)}$ | Power-up to initiation of write operation | | | 5 | ms |
| t_{RVCC} | V_{CC} Power up ramp rate | 0.2 | | 50 | V/msec |

Power-up Requirements (Power Up sequencing can affect correct recall of the wiper registers)

The preferred power-on sequence is as follows: First V_{CC} , then the potentiometer pins. It is suggested that V_{CC} reach 90% of its final value before power is applied to the

potentiometer pins. The V_{CC} ramp rate specification should be met, and any glitches or slope changes in the V_{CC} line should be held to <100mV if possible. Also, V_{CC} should not reverse polarity by more than 0.5V.

Notes: (5) This parameter is guaranteed by characterization or sample testing.

(6) t_{PUR} and t_{PUW} are the delays required from the time V_{CC} is stable until the specified operation can be initiated. These parameters are guaranteed by design.

(7) This parameter is guaranteed by design.





(8) Maximum Wiper Current is derated over temperature. See the Wiper Current Derating Curve.

(9) T_i value denotes the maximum noise glitch pulse width that the device will ignore on either SCL or SDA pins. Any noise glitch pulse width that is greater than this maximum value will be considered as a valid clock or data pulse and may cause communication failure to the device.

AC Conditions of Test

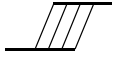
| | |
|--------------------------------|--|
| Input pulse levels | $V_{CC} \times 0.1$ to $V_{CC} \times 0.9$ |
| Input rise and fall times | 10ns |
| Input and output timing levels | $V_{CC} \times 0.5$ |

Symbol Table

| WAVEFORM | INPUTS | OUTPUTS |
|--|-----------------------------|-------------------------------|
|  | Must be steady | Will be steady |
|  | May change from LOW to HIGH | Will change from LOW to HIGH |
|  | May change from HIGH to LOW | Will change from HIGH to LOW |
|  | Don't Care: Changes Allowed | Changing: State Not Known |
|  | N/A | Center Line is High Impedance |

X9241A

Equivalent AC Test Circuit

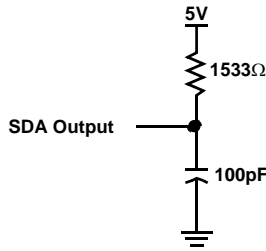

Guidelines for Calculating Typical Values of Bus Pull-Up Resistors

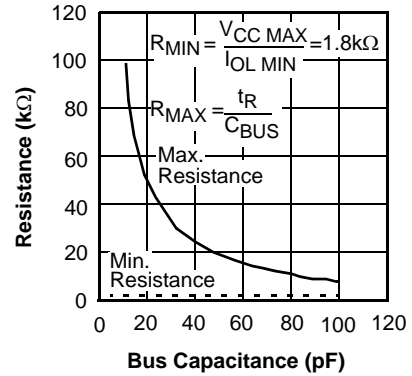

Circuit #3 SPICE Macro Model

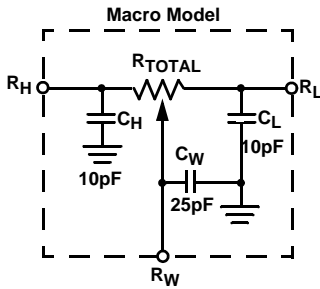

DCP Wiper Current De-rating Curve

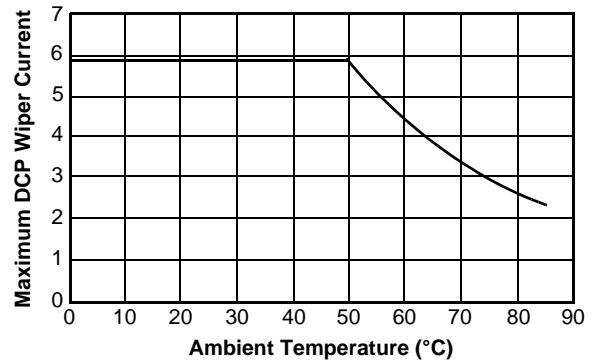

AC Electrical Specifications (Over recommended operating conditions unless otherwise stated.)

| SYMBOL | PARAMETER | LIMITS | | UNIT | REFERENCE FIGURE |
|--------------------|---|--------|------|------|------------------|
| | | MIN | MAX | | |
| $f_{SCL}^{(5)}$ | SCL clock frequency | 0 | 100 | kHz | 10 |
| $t_{LOW}^{(5)}$ | Clock LOW period | 4700 | | ns | 10 |
| $t_{HIGH}^{(5)}$ | Clock HIGH period | 4000 | | ns | 10 |
| $t_R^{(5)}$ | SCL and SDA rise time | | 1000 | ns | 10 |
| $t_F^{(5)}$ | SCL and SDA fall time | | 300 | ns | 10 |
| $T_i^{(5)(9)}$ | Noise suppression time constant (glitch filter) | | 20 | ns | 10 |
| $t_{SU:STA}^{(5)}$ | Start condition setup time (for a repeated start condition) | 4700 | | ns | 10 & 12 |
| $t_{HD:STA}^{(5)}$ | Start condition hold time | 4000 | | ns | 10 & 12 |
| $t_{SU:DAT}^{(5)}$ | Data in setup time | 250 | | ns | 10 |
| $t_{HD:DAT}^{(5)}$ | Data in hold time | 0 | | ns | 10 |
| $t_{AA}^{(5)}$ | SCL LOW to SDA data out valid | | 3500 | ns | 11 |
| $t_{DH}^{(5)}$ | Data out hold time | 50 | | ns | 11 |
| $t_{SU:STO}^{(5)}$ | Stop condition setup time | 4700 | | ns | 10 & 12 |
| $t_{BUF}^{(5)}$ | Bus free time prior to new transmission | 4700 | | ns | 10 |
| $t_{WR}^{(5)}$ | Write cycle time (nonvolatile write operation) | | 10 | ms | 13 |

X9241A

AC Electrical Specifications (Over recommended operating conditions unless otherwise stated.) (Continued)

| SYMBOL | PARAMETER | LIMITS | | UNIT | REFERENCE FIGURE |
|-------------------|--|--------|------|-------------------------|------------------|
| | | MIN | MAX | | |
| $t_{STPWV}^{(5)}$ | Wiper response time from stop generation | | 500 | μs | 13 |
| $t_{CLWV}^{(5)}$ | Wiper response from SCL LOW | | 1000 | μs | 6 |
| $t_R V_{CC}$ | V_{CC} power-up rate | 0.2 | 50 | $\text{mV}/\mu\text{s}$ | |

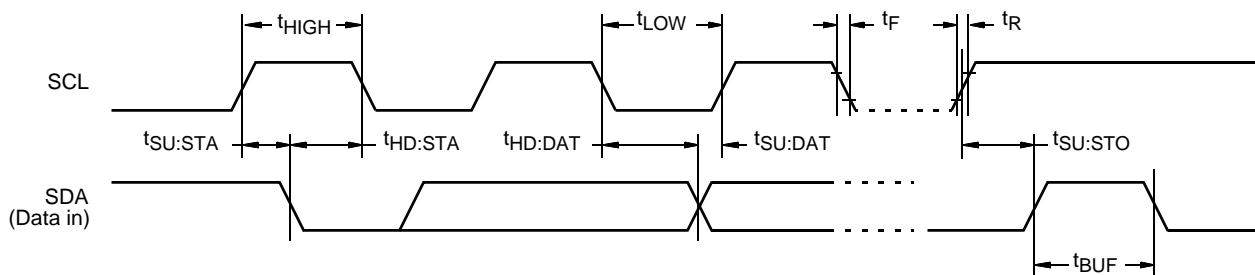

FIGURE 10. INPUT BUS TIMING

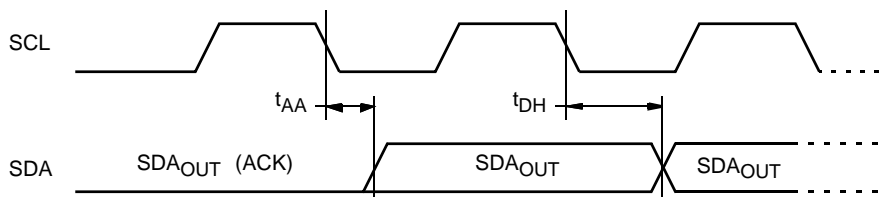

FIGURE 11. OUTPUT BUS TIMING

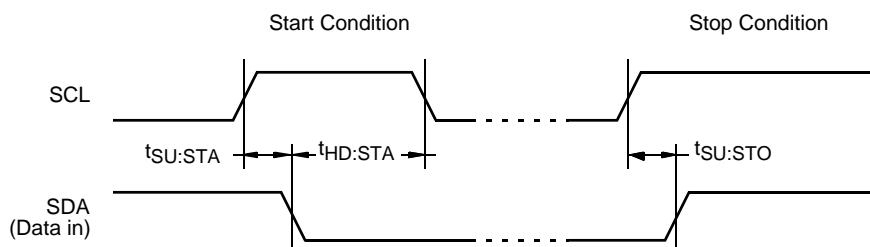

FIGURE 12. START STOP TIMING

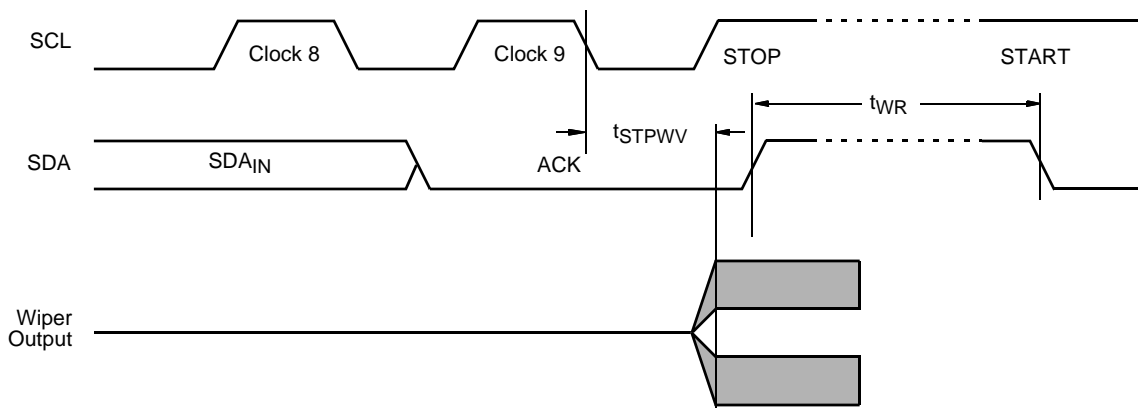
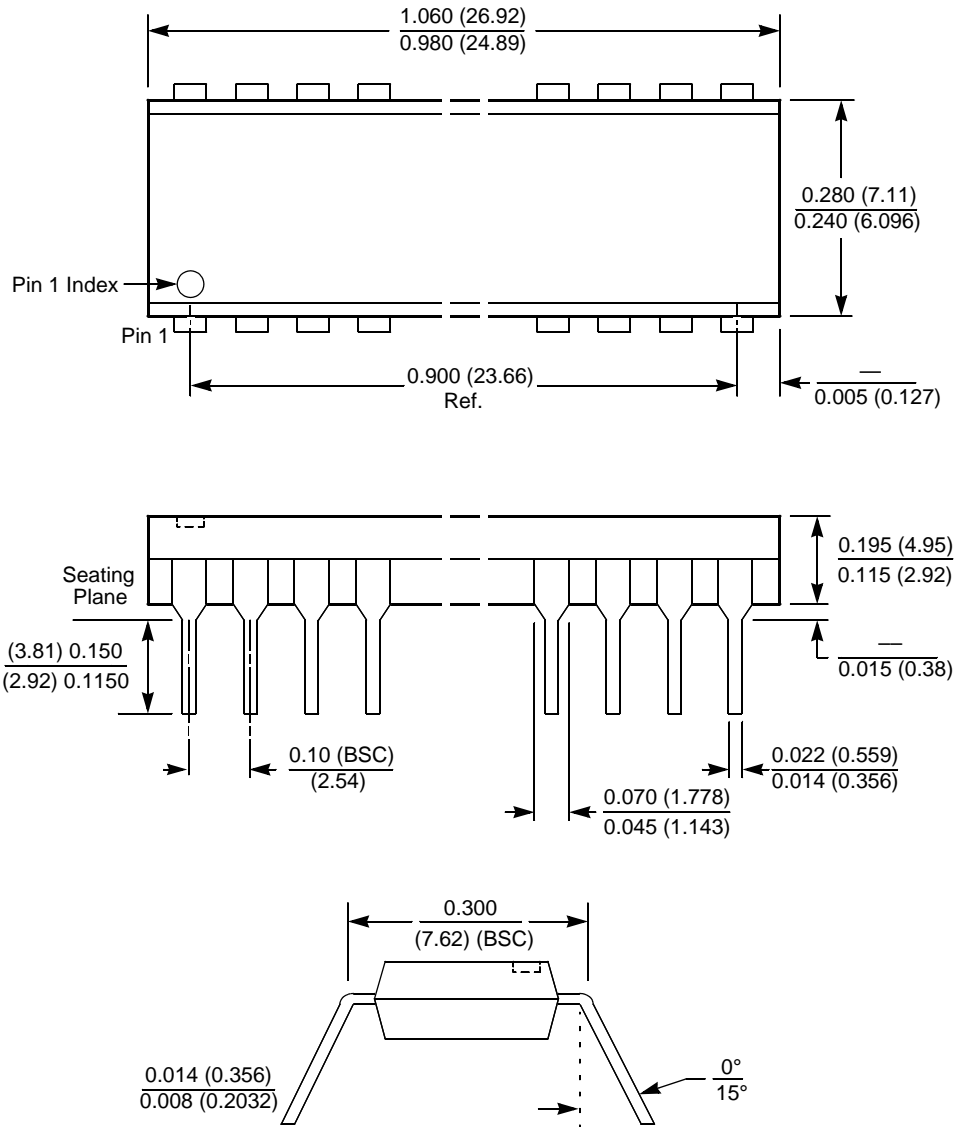

FIGURE 13. WRITE CYCLE AND WIPER RESPONSE TIMING

X9241A

Packaging Information

20-Lead Plastic Dual In-Line Package Type P



NOTE:

1. ALL DIMENSIONS IN INCHES (IN PARENTHESES IN MILLIMETERS)
2. PACKAGE DIMENSIONS EXCLUDE MOLDING FLASH

X9241A

Packaging Information

20-Lead Plastic Small Outline Gull Wing Package Type S

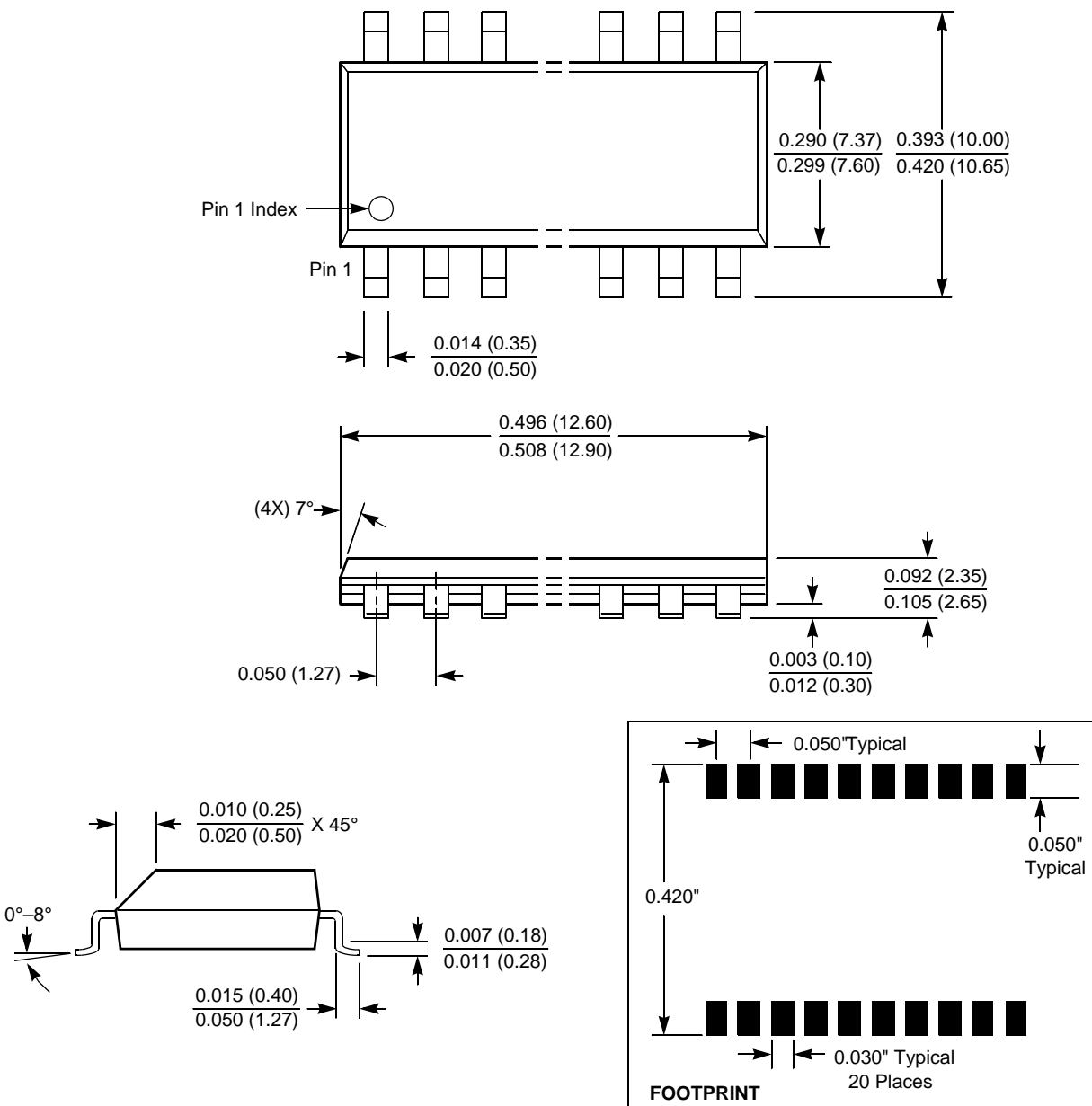

NOTE: ALL DIMENSIONS IN INCHES (IN PARENTHESES IN MILLIMETERS)

X9241A

Packaging Information

20-Lead Plastic, TSSOP, Package Type V

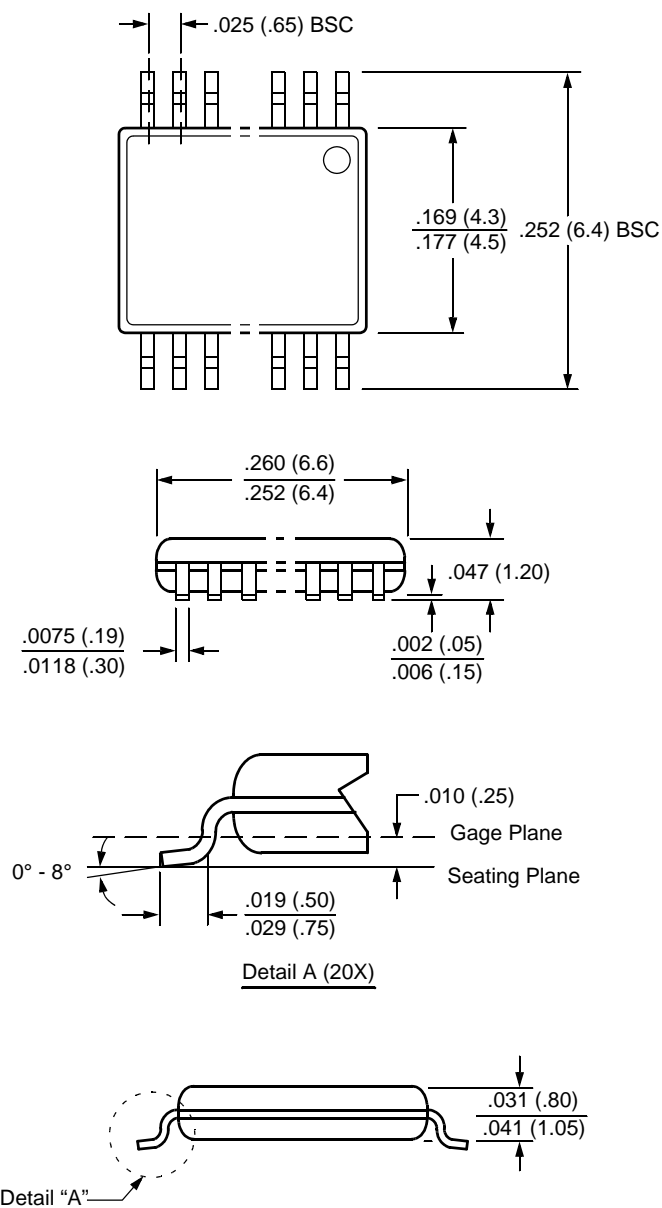

NOTE: ALL DIMENSIONS IN INCHES (IN PARENTHESES IN MILLIMETERS)

All Intersil U.S. products are manufactured, assembled and tested utilizing ISO9000 quality systems. Intersil Corporation's quality certifications can be viewed at www.intersil.com/design/quality

Intersil products are sold by description only. Intersil Corporation reserves the right to make changes in circuit design, software and/or specifications at any time without notice. Accordingly, the reader is cautioned to verify that data sheets are current before placing orders. Information furnished by Intersil is believed to be accurate and reliable. However, no responsibility is assumed by Intersil or its subsidiaries for its use; nor for any infringements of patents or other rights of third parties which may result from its use. No license is granted by implication or otherwise under any patent or patent rights of Intersil or its subsidiaries.

For information regarding Intersil Corporation and its products, see www.intersil.com