

SONY

CXA1446S

PLL-SPLIT System VIF, SIF

Description

The CXA1446S is an IF signal processor IC for CTVs and VCRs used in Japan and the U.S.A.

Features

- PLL synchronous detection ensures video detection output with less distortion
- Can receive external AGC
- Employs the PLL-SPLIT system, which enhances audio sensitivity and reduces buzzing
- Can also be used as intercarrier system
- The effect of interference is minimized as VCO oscillates at $f_p \times 1/2$
- Built-in audio volume

Absolute Maximum Ratings (Ta=25°C)

• Supply voltage	Vcc	17	V
• Operating temperature	Topr	-20 to +75	°C
• Storage temperature	Tstg	-65 to +150	°C
• Allowable power dissipation	Pd	1.35	W

Recommended Operating Conditions

Supply voltage	Vcc	9±0.5	V
----------------	-----	-------	---



Functions

VIF amplifier, PLL synchronous detection, AGC amplifier, ANC, internal stabilizing power supply, PLL-SPLIT system detection, AFT control output, AFT defeat, SIF limiter amplifier, quadrature detection, audio amplifier, audio output mute, electronic attenuator.

Structure

Bipolar silicon monolithic IC

Block Diagram and Pin Configuration (Top View)

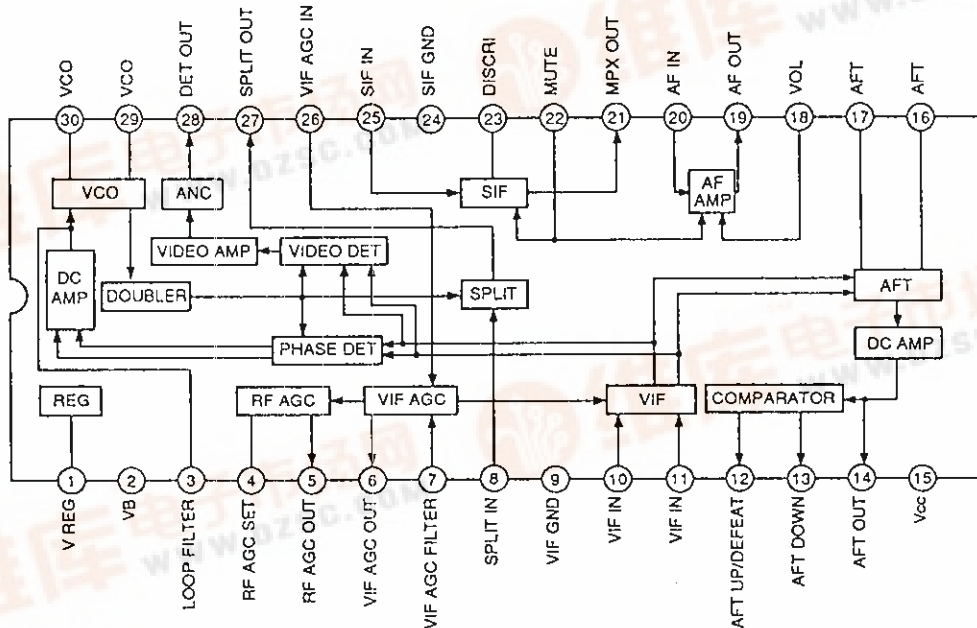

* Care must be taken in handling due to low electrostatic resistance.

Sony reserves the right to change products and specifications without prior notice. This information does not convey any license by any implication or otherwise under any patents or other right. Application circuits shown, if any, are typical examples illustrating the operation of the devices. Sony cannot assume responsibility for any problems arising out of the use of these circuits.



Pin Description and Equivalent Circuit

Pin No.	Symbol	Pin voltage	Equivalent circuit	Description
1	V REG	6.8V		Internal stabilizing power supply.
2	VB	9V		Ripple filter pin. A capacitor is connected externally for internal bias stabilization.
3	LOOP FILTER	2.7V		External pin of PLL loop filter.
4	RF AGC SET	3.8V*		Adjustment pin of RF AGC set voltage. This voltage is the comparator reference voltage.
5	RF AGC OUT	0V		RF AGC voltage output pin.
6	VIF AGC OUT	5.4V		VIF AGC voltage output pin.

* Applied externally

Pin No.	Symbol	Pin voltage	Equivalent circuit	Description
7	VIF AGC FILTER	9V		Time constant external pin of VIF AGC filter.
8	SPLIT IN	3V		Audio carrier input pin for pseudo split carrier type detection.
9	VIF GND	0V*		GND of VIF circuit.
10 11	VIF IN	3.3V		Video carrier input pin.
12	AFT UP/DEFEAT	0V		UP voltage output pin for AFT digital output. AFT output is defeated when voltage is 7V or more.
13	AFT DOWN	0V		DOWN voltage output pin for AFT digital output.

* Applied externally

Pin No.	Symbol	Pin voltage	Equivalent circuit	Description
14	AFT OUT	4.9V		AFT analog voltage output pin.
15	Vcc	9V*		Vcc pin.
16 17	AFT	6V		External pin of AFT coil.
18	VOL	0 to 9V*		Control pin of electronic attenuator.
19	AF OUT	4.8V		Audio signal output pin.
20	AF IN	3.1V		Audio signal input pin.

* Applied externally

Pin No.	Symbol	Pin voltage	Equivalent circuit	Description
21	MPX OUT	4.2V		Multiplex signal output pin.
22	MUTE	0 to 9V*		Pin which applies muting voltage.
23	DISCRI	0V		External pin of SIF detection coil.
24	SIF GND	0V*		GND for SIF circuit.
25	SIF IN	2.7V		SIF signal input pin.
26	VIF AGC IN	5V		Input pin for VIF AGC external voltage.

* Applied externally

Pin No.	Symbol	Pin voltage	Equivalent circuit	Description
27	SPLIT OUT	6.5V		SIF carrier output pin for pseudo split carrier type detection.
28	DET OUT	5.1V		VIF detection signal output pin.
29 30	VCO	5.7V		External pin of VCO oscillating coil.

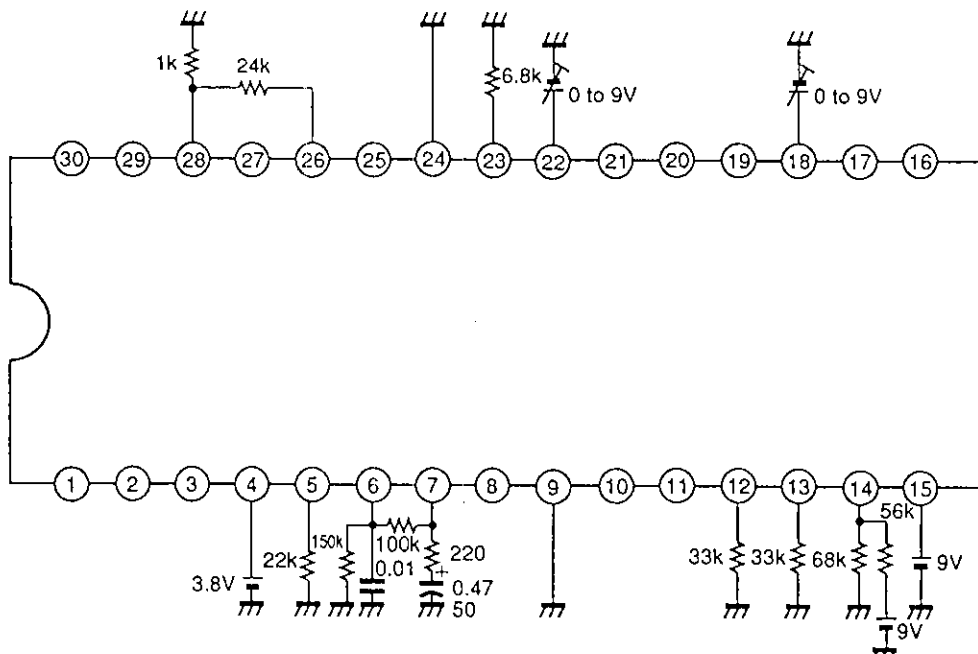

(Ta=25°C, Vcc=9V)

Electrical Characteristics

No.	Item	Symbol	Input signal	Level	Input point	Measurement conditions													Measurement point	Measurement content	Min.	Typ.	Max.	Unit			
						SW condition										Bias condition (V)											
						1	2	3	4	5	6	7	8	9	10	11	12	13							E1	E2	E3
1	Video Zero Carrier DC	Vzero				1																9		4.6	5.1	5.6	V
2*	Video AC Output	Vvac	58.75MHz, 15.75kHz, 87.5%TVAM	-20dBm	B				ON															1.7	2.0	2.3	Vp-p
3*	Video Distortion	VTHD	58.75MHz, 15.75kHz, 87.5%TVAM	-20dBm	B																			-	-	6	%
4*	VIF Sensitivity	Vsers	58.75MHz, 15.75kHz, 87.5%TVAM	-63dBm	B																			1.2	-	-	Vp-p
5*	VIF MAX Input	Vvmax	58.75MHz, 15.75kHz, 87.5%TVAM	-15dBm	B																			1.7	2.0	2.4	Vp-p
8*	Caputure-Range 1	CAP1	to 57.75MHz, CW	-30dBm	B																			-1	-	-	MHz
9*	Caputure-Range 2	CAP2	59.75MHz to, CW	-30dBm	B																			1	-	-	MHz
10*	VCO Hold Range 1	HOLD1	to 56.75MHz, CW	-30dBm	B																			-2	-	-	MHz
11*	VCO Hold Range 2	HOLD2	60.75MHz to, CW	-30dBm	B																			2	-	-	MHz
12	RF AGC MIN DC	VRMIN				ON											1							-	-	0.2	V
13	RF AGC MAX DC	VRMAX																9						7.2	7.5	7.8	V
14	AFT Zero Carrier DC	VFDC																9						2.5	4.2	6.0	V
15*	AFT Sensitivity	VFSENS	58.75MHz, 60Hz±25kHz FM	-30dBm	B				ON															1.4	2.0	2.6	Vp-p
16*	AFT MAX DC Output	VFMAX	57.75MHz, CW	-30dBm	B																			7.7	-	-	V

* For items with *, make sure to execute the ADJUST in the Notes on page 10 before measuring the item.

No.	Item	Symbol	Input signal	Level	Input point	Measurement conditions													Measurement Point	Measurement content	Min.	Typ.	Max.	Unit				
						SW condition										Bias condition (V)												
						1	2	3	4	5	6	7	8	9	10	11	12	13							E1	E2	E3	E4
17*	AFT MIN DC Output	V _{FMIN}	59.75MHz, CW	-30dBm	B	1																9	AFT OUT DC level for 59.75MHz input	-	-	0.7	V	
18*	AFT Defeat DC Output	V _{FDEO}	59.75MHz, CW	-30dBm	B						2							9					9	AFT OUT voltage when AFT is defeated	4.7	4.9	5.1	V
19*	AFT Defeat Drive DC	V _{FDED}	59.75MHz, CW	-30dBm	B													6 to 8					9	Voltage to defeat AFT	6.4	6.9	7.4	V
20	AFT UP DC Output	V _{FUO}									1	2						9					e	AFT UP high level	4.5	4.8	5.1	V
21	AFT UP Threshold DC	V _{FUT}											ON					6 to 7					e	AFT OUT level when AFT UP signal goes high	6.3	6.5	6.8	V
22	AFT Down DC Output	V _{FDOO}																1					f	AFT DOWN high level	4.5	4.8	5.1	V
23	AFT Down Threshold DC	V _{FDOO}											ON					2 to 3					f	AFT OUT level when AFT DOWN signal goes high	2.3	2.5	2.7	V
24*	Split Output	V _{SAC}	54.25MHz, CW	-45dBm	C								ON										j	Detection level of audio carrier	-7	-2	3.5	dBm
25*	MPX AC Output	V _{MAC}	4.5MHz, 1kHz±25kHz FM	-10dBm	A																		i	Output level of multiplex signal	300	420	550	mVrms
26*	MPX Distortion 1	M _{THD1}	4.5MHz, 1kHz±25kHz FM	-10dBm	A																		i	Distortion factor of multiplex output for typ. input	-	-	1	%
27*	MPX Distortion 2	M _{THD2}	4.5MHz, 1kHz±100kHz FM	-10dBm	A																		i	Distortion factor of multiplex output for overmodulation	-	-	3	%
28*	SIF Sensitivity	V _{MSns}	4.5MHz, 1kHz±25kHz FM	-55dBm	A																		i	Multiplex output for weak electric field input	0.2	-	-	Vrms
29*	AM Rejection Ratio	V _{AMRR}	4.5MHz, 1kHz 30% AM	-10dBm	A																		i	AM elimination, 20 log (V _{MAC} /V _{AMRR})	30	-	-	dB
30*	MPX Mute AC Output	V _{MMAC}	4.5MHz, 1kHz±25kHz FM	-10dBm	A																		i	Multiplex output for MUTE ON	-	-	0.1	mVrms

* For items with *, make sure to execute the ADJUST in the Notes on page 10 before measuring the item.

No.	Item	Symbol	Input signal	Level	Input point	Measurement conditions														Measurement point	Min.	Typ.	Max.	Unit		
						SW condition										Bias condition (V)										
						1	2	3	4	5	6	7	8	9	10	11	12	13	E1						E2	E3
31	MPX Mute DC Output	V _{MDC}				1																i	3.9	4.2	4.5	V
32*	MPX Mute Drive DC	V _{MDD}	4.5MHz, 1kHz±25kHz FM	-10dBm	A																	i	1.0	3.0	3.5	V
33	AF AC Output	V _{AAC1}	1kHz	0.35V	D																	h	3.5	5.8	7.3	dB
34	0dB Volium DC	V _{AAC2}	1kHz	0.35V	D																	h	4.2	5.2	6.2	V
35	AF Distortion	ATHD	1kHz	0.35V	D																	h	-	-	1.5	%
36	AF DC Output	V _{ADC}																				h	4.4	4.8	5.2	V
37	AF Mute AC Output	V _{AMAC}	1kHz	0.35V	D																	h	-	-	0.8	mVrms
38	AF Mute DC Offset	V _{AMDC}																				h	-	-	0.4	V
39	Regulator DC Output	V _{REG}																				a	6.4	6.8	7.2	V
40	Current consumption	I _{CC}	58.75MHz, CW	-20dBm	B																	Ⓐ	45	58	80	mA

* For items with *, make sure to execute the ADJUST in the Notes on page 10 before measuring the item.

Electrical Characteristics Measurement Circuit

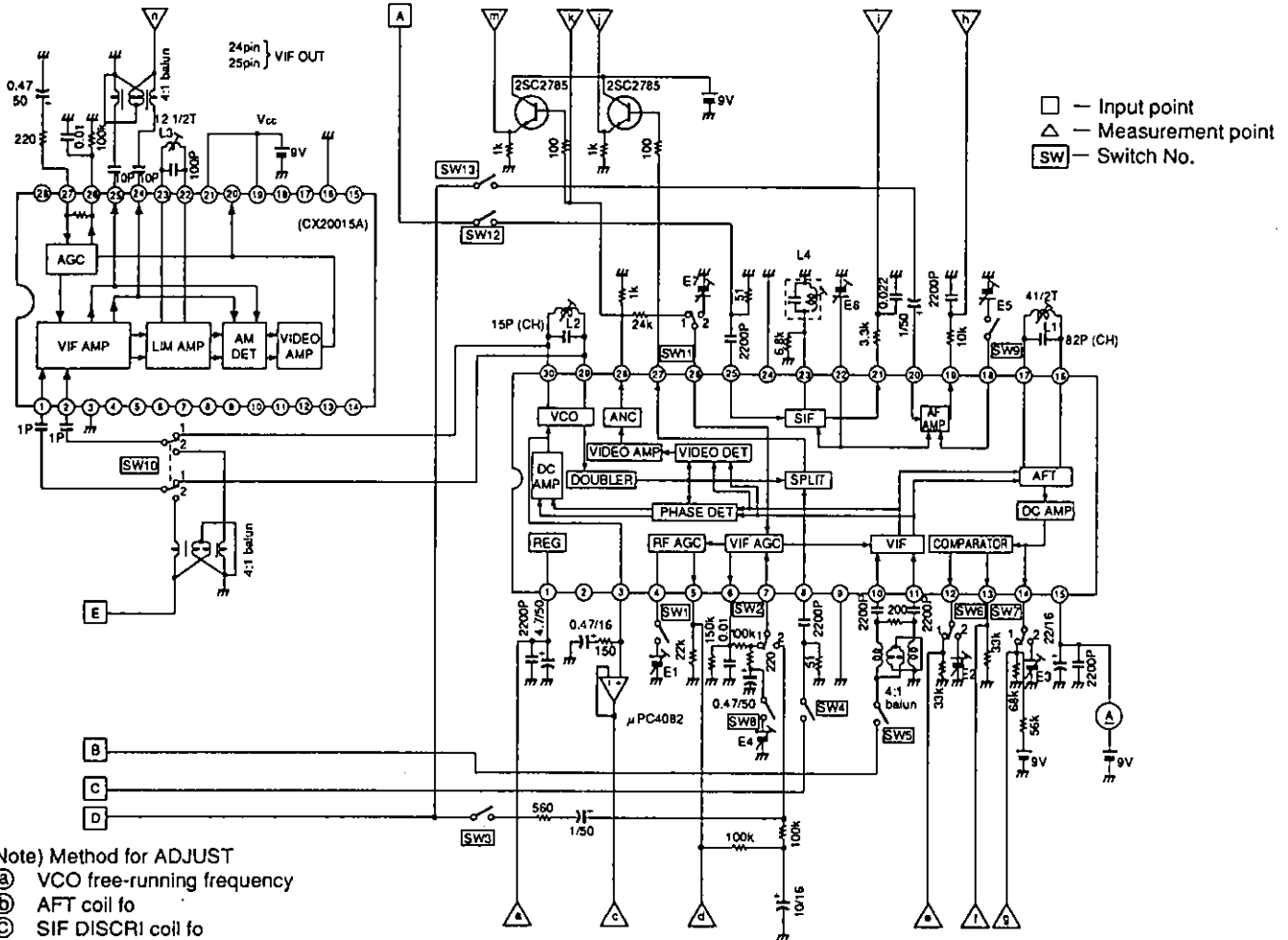

Measurement conditions

	Input signal	Level	Input point	SW condition													Bias condition (V)							Measurement point			
				1	2	3	4	5	6	7	8	9	10	11	12	13	E1	E2	E3	E4	E5	E6	E7				
Ⓐ	29.375MHz, CW	-20dBm	E		1					1	1	ON		2		1											n
Ⓑ	58.75MHz, CW	-30dBm	B					ON						1													g
Ⓒ	4.5MHz, CW	-10dBm	A									ON				ON											i

Adjusting Method

- a) Adjustment of VCO free-running frequency (L2, L3) (The CXA20015A is used as an amplifier for measuring VCO oscillation frequency with frequency counters.)
 - (1) Input a 29.375MHz signal at input point E. Adjust L3 coil so that the level at measurement point n is maximum.
 - (2) Switch SW10 from "2" to "1".
 - (3) Adjust L2 coil so that the frequency at measurement point n is 29.375MHz.
- b) Adjustment of AFT coil fo (L1)
 - (1) Input a 58.75MHz signal at input point B.
 - (2) Adjust L1 coil so that the DC level at measurement point i is 4.5V.
- c) Adjustment of SIF DISCRI coil fo (L4)
 - (1) Input a 4.5MHz signal at input point A.
 - (2) Adjust L4 coil so that the DC level at measurement point j is MPX MUTE DC voltage.

Description of Operation

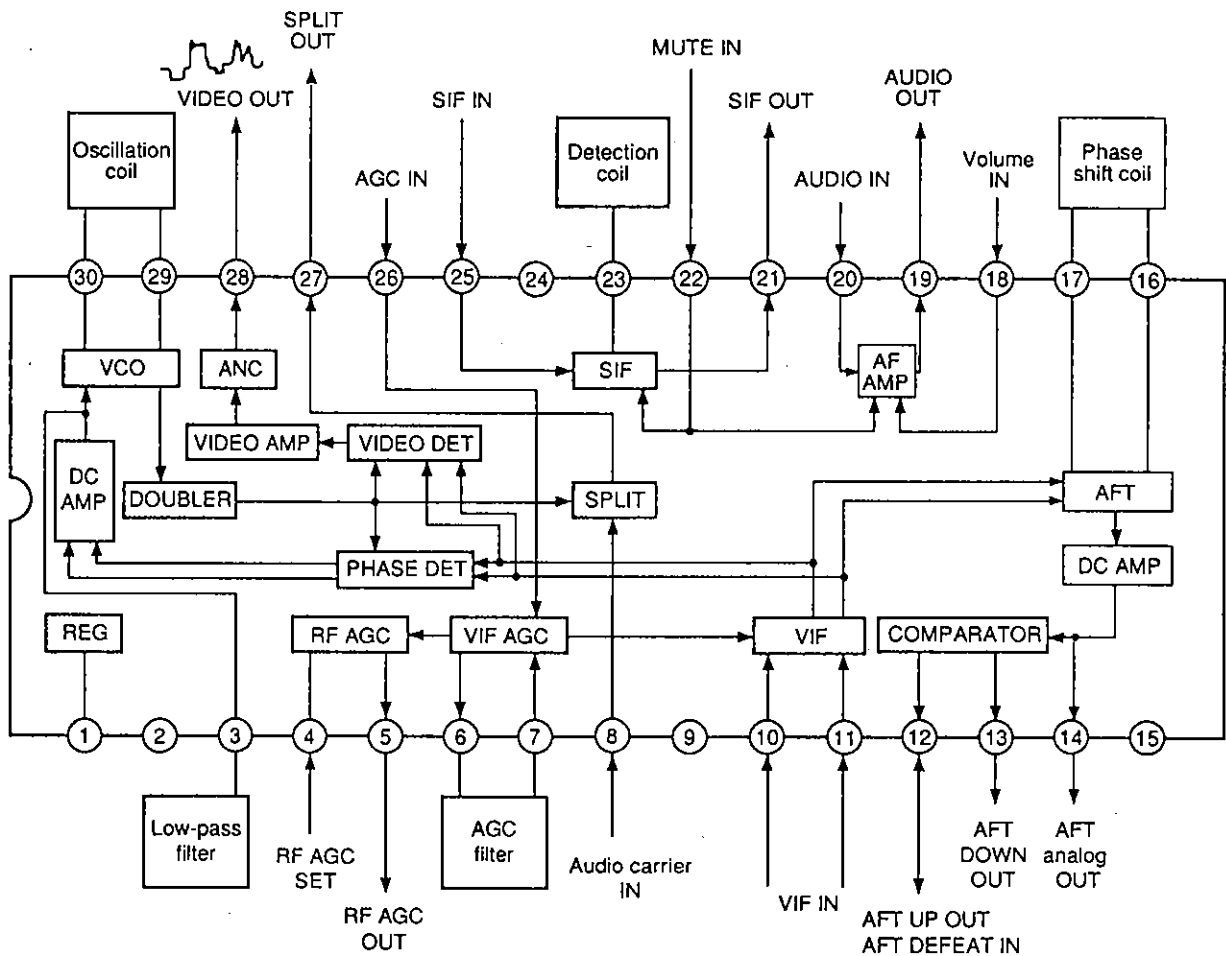

(1) VIF detection circuit

VIF signal input to Pins 10 and 11 (VIF IN) is detected by the continuous waves synchronous with the video carrier waves obtained from PLL. The detected signal is amplified at VIDEO AMP, and after the elimination of over signal noise at the ANC circuit, it is output from Pin 28 (DET-OUT).

(2) PLL circuit

The VCO 29.375MHz signal is doubled to 58.75MHz at DOUBLER. A signal proportional to the phase comparison between the DOUBLER output signal and the input VIF signal carrier wave is passed through the low-pass filter and is fed back to VCO.

Through this loop, the VCO signal is synchronized with the carrier wave of the input VIF signal.

(3) AGC circuit

AGC signal input to Pin 26 (VIF AGC-IN) passes through the AGC filter to be applied to each stage of the VIF amplifier. Then, it is compared to RF AGC SET voltage at Pin 4 and RF AGC voltage is output to Pin 5.

(4) AFT Circuit

AFT voltage is made by comparing the phases of carrier wave of the VIF signal input to Pins 10 and 11 (VIF-IN), and the carrier which passed through the 58.75MHz external phase shifter. This voltage is amplified at DC AMP and output from Pin 14 (AFT-OUT). Then, comparing with the reference voltage by means of the comparator circuit, the UP signal is output from Pin 12 and the DOWN signal (TTL level) is output from Pin 13. AFT output is defeated when a voltage of 7V or more is applied to Pin 12.

(5) PLL-SPLIT type detection circuit

The audio carrier signal input from Pin 8 (SPL-IN) is frequency converted by the continuous wave synchronous to the VIF video carrier wave, and output from Pin 27 (SPL-OUT).

(6) SIF detection circuit

The 4.5MHz SIF signal input from Pin 25 (SIF-IN), passes through the limiter amplifier, is FM detected by the quadrature detection circuit and output from Pin 21 (MPX-OUT). At that time, if a voltage of 3.5V or more is applied to Pin 22, the output of Pin 21 (MPX-OUT) is muted.

(7) AUDIO circuit

The AUDIO signal input from Pin 20 (AF-IN) is amplified at the AF AMP and output from Pin 19 (AF-OUT).

AF AMP gain is controlled by the volume voltage applied from Pin 18. Then, by applying a voltage of 3.5V or more to Pin 22, the output of Pin 19 (AF-OUT) is muted.

Application Circuit for Japan (U.S.)

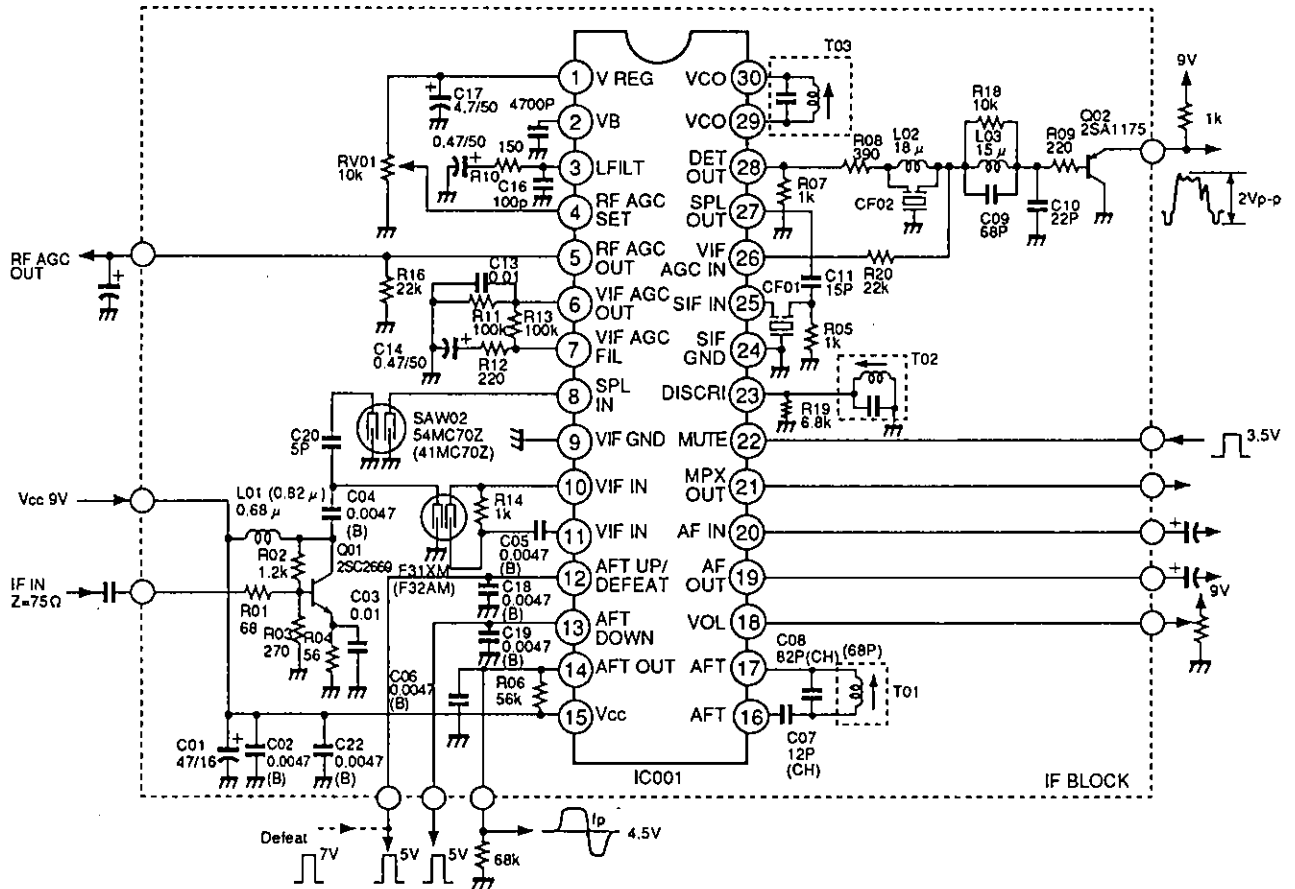

Application circuits shown are typical examples illustrating the operation of the devices. Sony cannot assume responsibility for any problems arising out of the use of these circuits or for any infringement of third party patent and other right due to same.

Coil Specifications

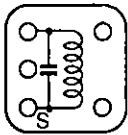
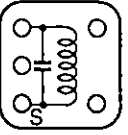
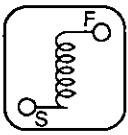
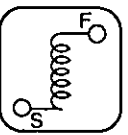
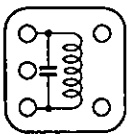
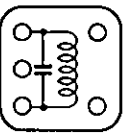
	fp=58.75MHz (JAPAN)	fp=45.75MHz (USA)
VCO COIL (7k)	 <p>T=11 1/2 0.1 φ C=24pF</p>	 <p>T=16 0.1 φ C=24pF</p>
AFT COIL (7k)	 <p>T=4 1/2 0.5 φ</p>	 <p>T=7 1/2 0.5 φ</p>
DISCRI COIL (7k)	 <p>T=35 0.09 φ C=100pF</p>	 <p>T=35 0.09 φ C=100pF</p>

(Bottom View)

Examples of Representative Characteristics

Pin 14 voltage vs. Frequency

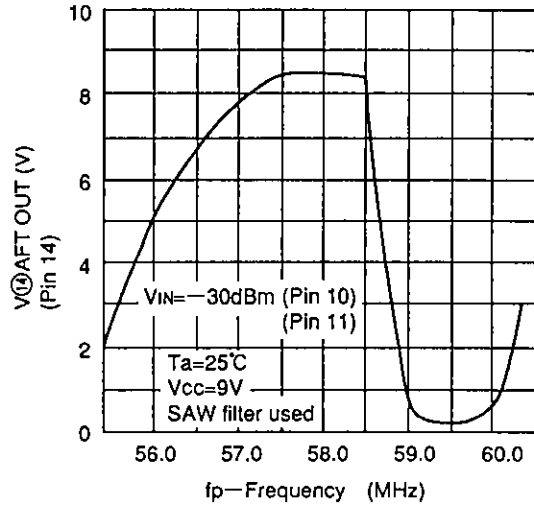

Pins 12, 13, 14 voltage vs. Frequency

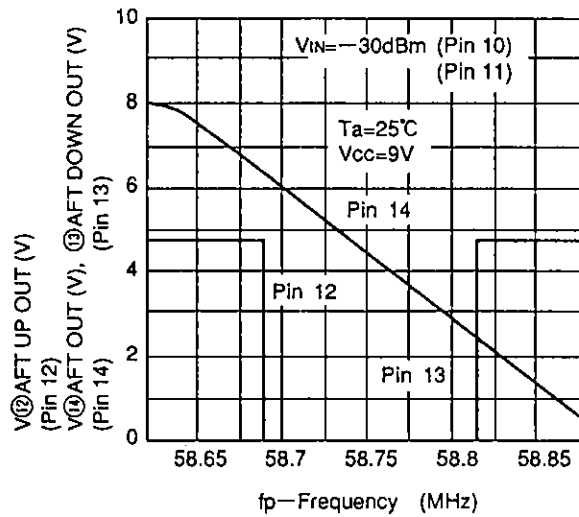

Audio amplifier gain vs. Pin 18 voltage

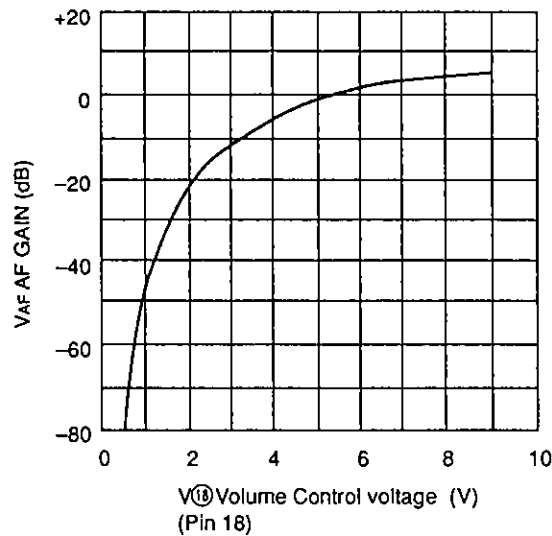

Package Outline Unit : mm

30pin SDIP (Plastic) 400mil 1.8g

