

**SONY**

**CXA1452N**

**Carrier/Deviation/Filter Adjustment for 8mm VCRs**

**Description**

The CXA1452N is an electrical volume IC for carrier/deviation/filter adjustment dedicated to the CXA1207AR/AQ, to facilitate adjustment automation (compatible with the electrical volume) in 8mm VCRs.

**Features**

- Equipped with the following built-in functions:  
Carrier adjustment  
Deviation adjustment  
Filter adjustment  
(IR adjustment of the CXA1207AR/AQ)
- The CXA1452N can be used in combination with the CXA1211M to form a CXA1207AR/AQ-peripheral electrical volume system.

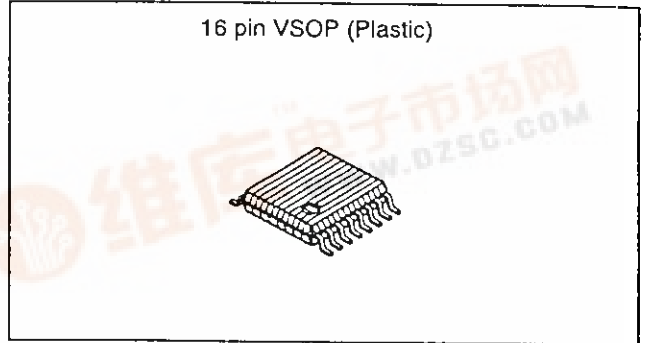

**Structure**

Bipolar silicon monolithic IC

**Application**

8mm VCRs

**Absolute Maximum Ratings**

- Supply voltage  $V_{cc}$  6 V
- Operating temperature  $T_{opr}$  -20 to +75 °C
- Storage temperature  $T_{stg}$  -40 to +125 °C
- Allowable power dissipation  $P_d$  275 mW

**Recommended Operating Conditions**

Supply voltage  $V_{cc}$  4.75 ± 0.25 V

**Block Diagram and Pin Configuration**

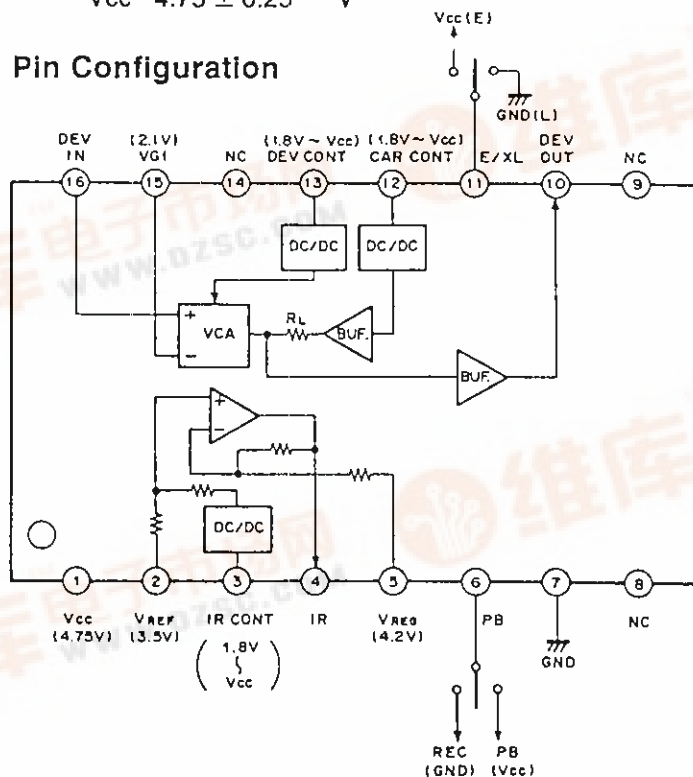

Sony reserves the right to change products and specifications without prior notice. This information does not convey any license by any implication or otherwise under any patents or other right. Application circuits shown, if any, are typical examples illustrating the operation of the devices. Sony cannot assume responsibility for any problems arising out of the use of these circuits.



Pin Description

\* Externally applied voltage

Pin No.	Symbol	Pin voltage	Equivalent circuit	Description
1	Vcc	4.75V*	—	Power supply.
2	VREF	approx. 3.5V*		Connects to Pin 14 of the CXA1207AR/AQ.
3	IR CONT	1.8V to Vcc		Applies DC voltage for IR adjustment (filter adjustment).

Pin No.	Symbol	Pin voltage	Equivalent circuit	Description
4	IR	—		<p>IR adjustment (filter adjustment) output. Connects to Pin 8 of the CXA1207AR/AQ through a 22kΩ metallic film resistor.</p>
5	VREG	4.2V*	—	Connects to Pin 6 of the CXA1207AR/AQ.
6	PB	<p>PB: 2.7V and above*</p> <p>REC: 2.1V and below*</p>		<p>REC/PB selection switchover. Power can be saved during PB by turning off the carrier deviation adjustment circuit.</p>

Pin No.	Symbol	Pin voltage	Equivalent circuit	Description
7	GND	0V*	—	GND.
8	NC	—	—	No connection. Under normal conditions, connect to GND.
9	NC	—	—	No connection. Under normal conditions, connect to GND.
10	DEV OUT	—		Output for signals adjusted for carrier deviation. Connected to Pin 54 of the CXA1207AR/AQ through a 2.7kΩ metallic film resistor.
11	E/XL	E (Hi8): 3.2V and above* L (standard): 2.1V and below*		Hi8 mode/standard mode selection switchover.

Pin No.	Symbol	Pin voltage	Equivalent circuit	Description
12	CAR. CONT	1.8V to Vcc *		Applies DC voltage for carrier adjustment.
13	DEV CONT	1.8V to Vcc *		Applies DC voltage for deviation adjustment.

Pin No.	Symbol	Pin voltage	Equivalent circuit	Description
14	NC	—	—	No connection. Under normal conditions, connect to GND.
15	VGI	2.1V*		Connects to Pin 60 of the CXA1207AR/AQ.
16	DEV IN	2.1V		Y signal input for carrier and deviation adjustment. Connects to Pin 57 of the CXA1207AR/AQ.

## Electrical Characteristics

(Ta=25°C, Vcc=4.75V)

No.	Item	Symbol	Conditions	Min.	Typ.	Max.	Unit	Remarks
1	Circuit current (REC)	ICCR	SG: no input SW1: OFF V3, V12, V13=3.275V V11=4.75V V16=2.1V V6=GND	5.0	7.0	9.0	mA	
2	Circuit current (PB)	ICCP	SG: no input SW1: OFF V3, V12, V13=3.275V V11=4.75V V16=2.1V V6=4.75V	1.5	1.9	2.4	mA	
3	Deviation control maximum gain (E mode)	D <sub>MAXE</sub>	SG: 300kHz, 0.83Vp-p V3, V12=3.275V V11, V13=4.75V V16=2.26V V6=GND Test at TP10	3.8	4.1	4.4	dB	
4	Deviation control minimum gain (E mode)	D <sub>MIN E</sub>	SG: 300kHz, 0.83Vp-p V3, V12=3.275V V11=4.75V V13=1.8V V16=2.26V V6=GND Test at TP10	-3.3	-2.8	-2.3	dB	
5	Deviation control maximum gain (L mode)	D <sub>MAXL</sub>	SG: 300kHz, 0.88Vp-p V3, V12=3.275V V6, V11=GND V13=4.75V V16=2.28V Test at TP10	-0.4	-0.1	0.2	dB	
6	Deviation control minimum gain (L mode)	D <sub>MINL</sub>	SG: 300kHz, 0.88Vp-p V3, V12=3.275V V6, V11=GND V13=1.8V V16=2.28V Test at TP10	-7.4	-6.9	-6.4	dB	
7	Deviation control frequency characteristics (E mode)	D <sub>fE</sub>	SG: 5MHz/300kHz, 0.5Vp-p V3, V12=3.275V V11=4.75V V16=2.1V V6=GND Test at TP10 V13=1.8V, 3.275V, 4.75V Confirm at each	-0.3	-0.1	0.1	dB	
8	Deviation control frequency characteristics (L mode)	D <sub>fL</sub>	SG: 5MHz/300kHz, 0.5Vp-p V3, V12=3.275V V6, V11=GND V16=2.1V Test at TP10 V13=1.8V, 3.275V, 4.75V Confirm at each	-0.3	-0.1	0.1	dB	

No.	Item	Symbol	Conditions	Min.	Typ.	Max.	Unit	Remarks
9	Carrier control maximum DC electric potential (E mode)	C <sub>MAXE</sub>	SG: no input V3, V13=3.275V V11=4.75V V6=GND V16=2.1V V12=4.75V Test at TP10	3.00	3.02	3.04	V	
10	Carrier control minimum DC electric potential (E mode)	C <sub>MIN E</sub>	SG: no input V3, V13=3.275V V11=4.75V V6=GND V16=2.1V V12=1.8V Test at TP10	2.74	2.76	2.78	V	
11	Carrier control maximum DC electric potential (L mode)	C <sub>MAXL</sub>	SG: no input V3, V13=3.275V V6, V11=GND V16=2.1V V12=4.75V Test at TP10	2.79	2.81	2.83	V	
12	Carrier control minimum DC electric potential (L mode)	C <sub>MINL</sub>	SG: no input V3, V13=3.275V V6, V11=GND V16=2.1V V12=1.8V Test at TP10	2.53	2.55	2.57	V	
13	Deviation control secondary, third-phase distortion (E mode)	DdE	SG: 5MHz, 0.83Vp-p V3, V12=3.275V V11=4.75V V16=2.26V V6=GND Test at TP10 V13=1.8V, 3.275V, 4.75V Confirm at each	—	—	-40	dB	
14	Deviation control secondary, third-phase distortion (L mode)	DdL	SG: 5MHz, 0.88Vp-p V3, V12=3.275V V6, V11=GND V16=2.28V Test at TP10 V13=1.8V, 3.275V, 4.75V Confirm at each	—	—	-40	dB	
15	IR output maximum DC electric potential	I <sub>RMAX</sub>	SG: no input V12, V13=3.275V V6, V11=GND V16=2.1V V3=4.75V Test at TP4	3.22	3.24	3.26	V	
16	IR output minimum DC electric potential	I <sub>RMIN</sub>	SG: no input V12, V13=3.275V V6, V11=GND V16=2.1V V3=1.8V Test at TP4	2.41	2.43	2.45	V	



No.	Item	Symbol	Conditions	Min.	Typ.	Max.	Unit	Remarks
17	PB mode switching voltage	PV <sub>TH</sub>	SG: 5MHz, 1Vp-p V12=3.275V V3, V11, V13=4.75V V16=2.25V V6=variable Test at TP4, 10	2.7	—	4.75	V	Note 1
18	REC mode switching voltage	RV <sub>TH</sub>	SG: 5MHz, 1Vp-p V12=3.275V V3, V11, V13=4.75V V16=2.25V V6=variable Test at TP4, 10	0	—	2.1	V	Note 2
19	E mode switching voltage	EV <sub>TH</sub>	SG: 5MHz, 1Vp-p V12=3.275V V3, V11, V13=4.75V V16=2.25V V6=variable Test at TP4, 10	3.2	—	4.75	V	Note 3
20	L mode switching voltage	VV <sub>TH</sub>	SG: 5MHz, 1Vp-p V12=3.275V V3, V11, V13=4.75V V16=2.25V V6=variable Test at TP4, 10	0	—	2.1	V	Note 4

## Reference Values

Item	Symbol	Conditions	Typ.	Unit	Remarks
Deviation control S/N (E mode)	D <sub>NE</sub>	SG: luminance signal for S/N test V3, V12=3.275V V6, V11=GND V16=adjust to synchronization chip 2.1V Test at TP10 (at maximum gain)	61	dB	Note 5
Deviation control S/N (L mode)	D <sub>NL</sub>	SG: luminance signal for S/N test V3, V12=3.275V V6, V11=GND V16=adjust to synchronization chip 2.1V Test at TP10 (at maximum gain)	57	dB	Note 5

**Note 1)**

When  $V_6=2.7V$  or above, confirm that:

Standard value for No. 17 is satisfied at TP4.

Output is terminated at TP10.

Confirm that circuit current satisfies standard values for No. 2.

**Note 2)**

When  $V_6=2.2V$  or below, confirm that:

Standard values for No. 17 are satisfied at TP4.

Standard values for No. 3 are satisfied at TP10.

Circuit current satisfies standard values for No. 1.

**Note 3)**

When  $V_{11}=3.2V$  or above, confirm that:

Standard values for No. 3 are satisfied at TP10.

**Note 4)**

When  $V_{11}=2.1V$  or below, confirm that:

Standard values for No. 5 are satisfied at TP10.

**Note 5)**

Luminance signal for S/N test

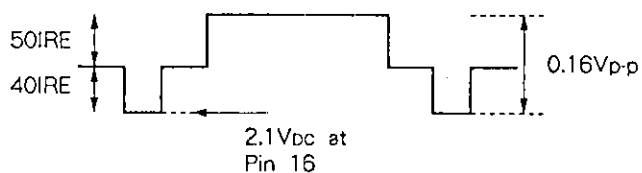

Band restrictions of S/N test equipment are:

HPF=100kHz

LPF=4.2MHz

Test Circuit

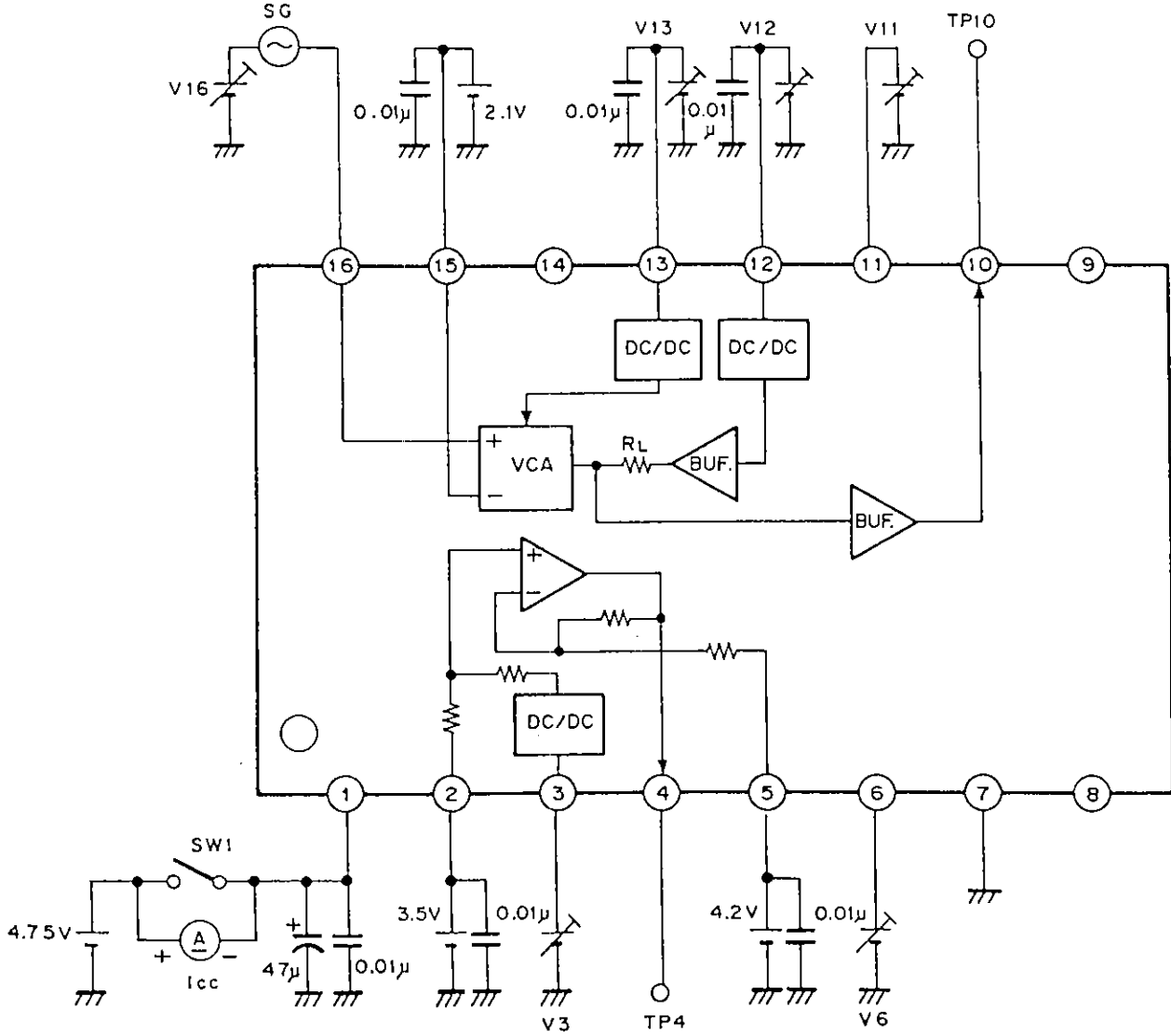

SW1 : ON when not specified.

Application Circuit

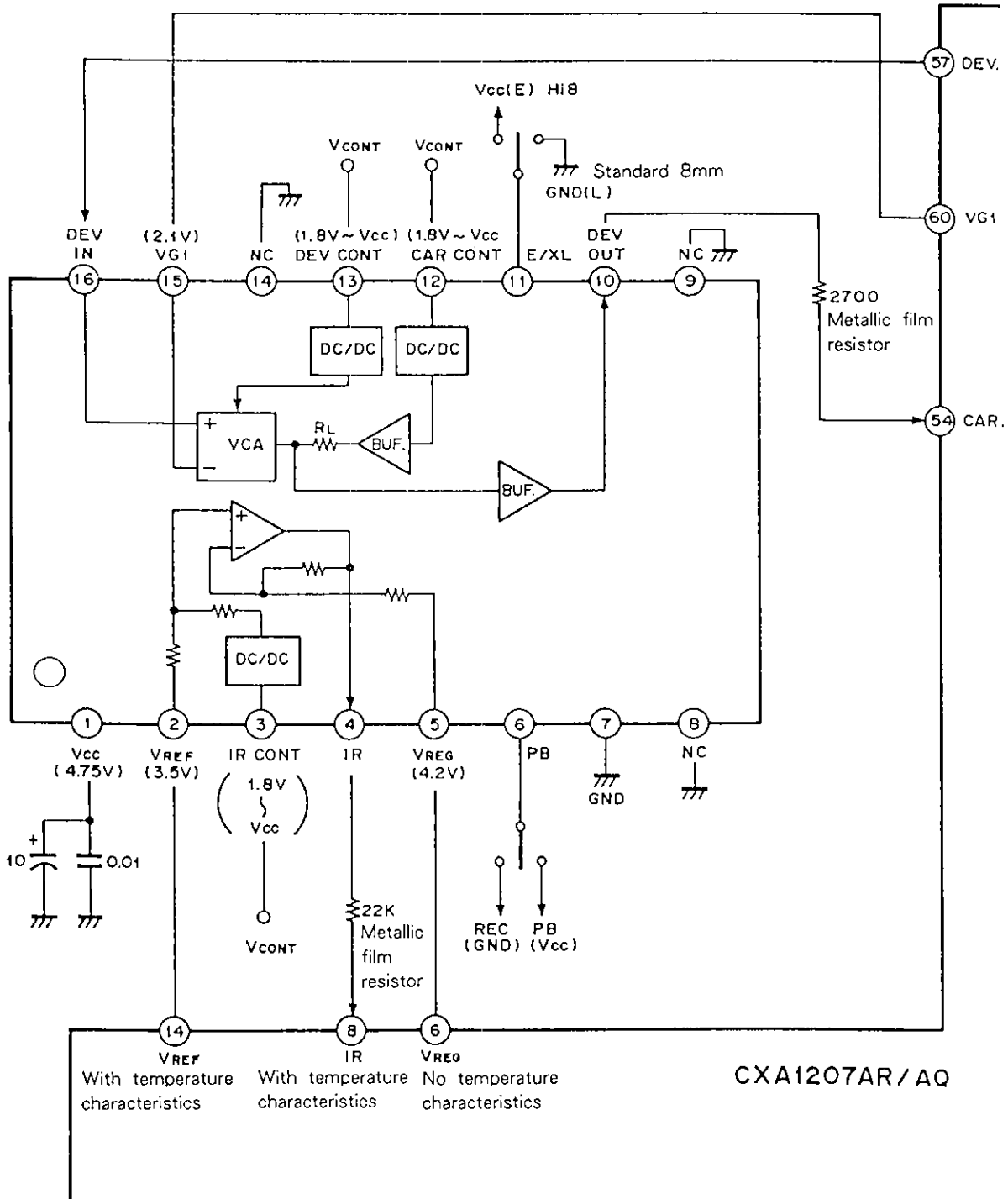

Application circuits shown are typical examples illustrating the operation of the devices. Sony cannot assume responsibility for any problems arising out of the use of these circuits or for any infringement of third party patent and other right due to same.

Package Outline Unit : mm

16pin VSOP (Plastic) 225mil

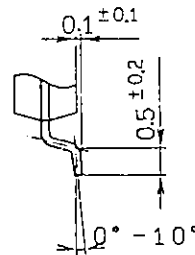
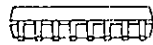
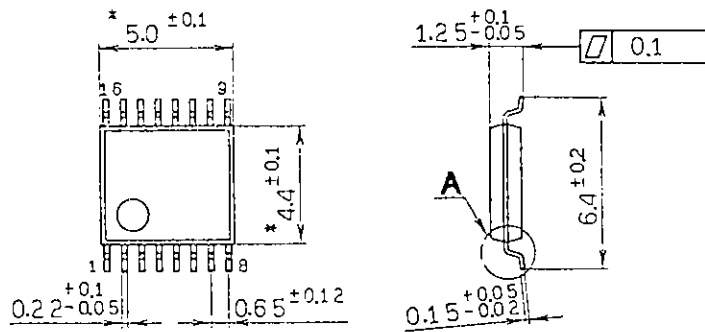

Detailed diagram of A

Note) Dimensions marked with \* does not include resin residue.

SONY NAME	VSOP-16P-L031
EIAJ NAME	SSOP016-P-0225-AM
JEDEC CODE	_____