

SONY

CXA1594L/L-S

All Band TV Tuner IC (VHF-CATV-UHF)

Description

The CXA1594L/L-S is a single chip tuner IC which performs as an oscillator mixer for VHF/CATV bands and UHF bands. An IF amplifier is also provided.

Use of this IC enables a large reduction of external parts in addition to the miniaturization of the tuner, improving manufacturing productivity, reliability, and ease of design.

This IC is similar in circuit to CXA1355L with pin arrangements modified to simplify installation in tuners.

Features

- On-chip UHF band OSC and MIX
- Low noise figure
- Reduced spurious interference
- Superior cross modulation distortion
- Ultra-small package ensures tuner miniaturization

Applications

- CTV tuner
- CATV UP-DOWN converter
- FM detector for 2IF satellite broadcasts

Structure

Bipolar silicon monolithic IC

Block Diagram and Pin Configuration

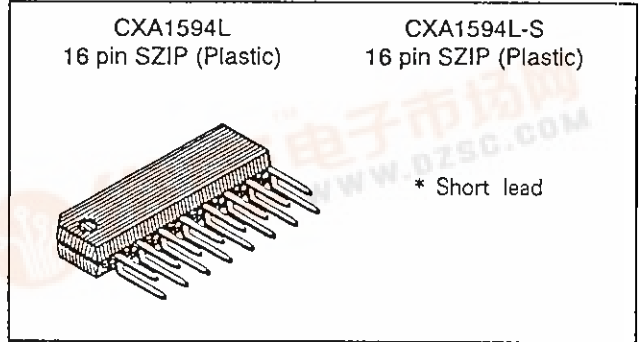
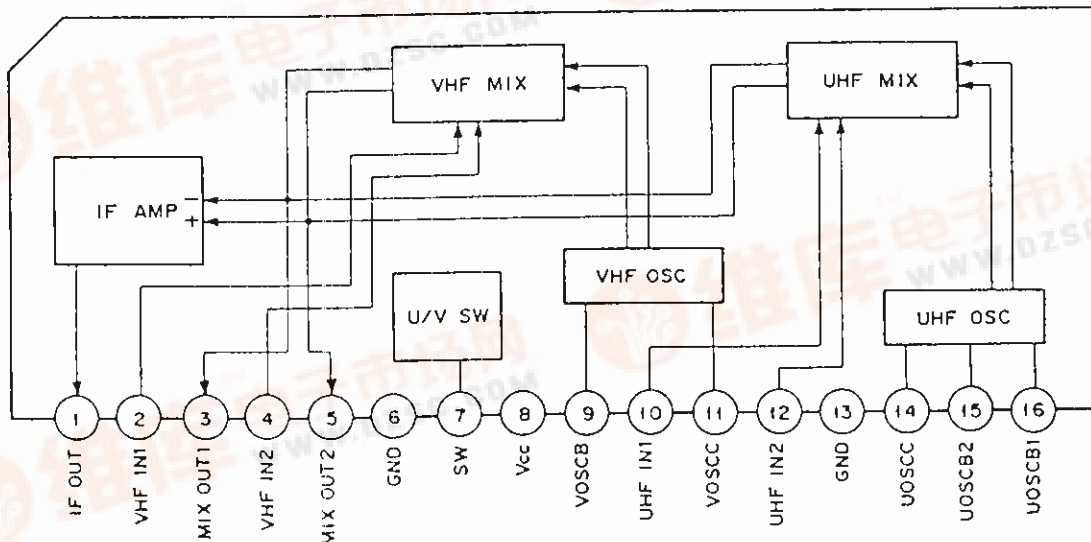

Absolute Maximum Ratings (Ta=25°C)

• Supply voltage	Vcc	12	V
• Storage temperature	Tstg	-55 to +150	°C
• Allowable power dissipation	Pd	800	mW

Recommended Operating Conditions

• Supply voltage	Vcc	8.1 to 9.9	V
• Ambient temperature	Topr	-20 to +75	°C

Sony reserves the right to change products and specifications without prior notice. This information does not convey any license by any implication or otherwise under any patents or other right. Application circuits shown, if any, are typical examples illustrating the operation of the devices. Sony cannot assume responsibility for any problems arising out of the use of these circuits.



Pin Description

Pin No.	Symbol	Typical voltage (V)	Equivalent circuit	Description
1	IF OUT	Under VHF operation 5.4 Under UHF operation 5.4		IF output.
2	VHF IN1	2.8 3.2		VHF input. Normally a condenser is connected at Pin 2 to GND and Pin 4 is used for input.
4	VHF IN2	2.8 3.2		
3	MIX OUT1	7.8 7.7		Doubles as mixer output and IF amp input.
5	MIX OUT2	7.8 7.7		
6	GND	0		GND
7	SW	3V or more 0.3V or less		UV switch pin. Connect 9V source through a resistor of about 5kΩ for VHF reception; leave OPEN (0V) for UHF.

Pin No.	Symbol	Typical voltage (V)	Equivalent circuit	Description
8	Vcc	9.0		Power supply (9V).
9	V OSCB	2.8 3.4		VHF oscillator. Since Pin 11 is an open collector, connect power supply through a choke coil or a resistor of about 500Ω .
11	V OSCC	9.0 9.0		
10	UHF IN1	3.2 2.8		UHF input. The differential signal input to Pin 11 and 12.
12	UHF IN2	3.2 2.8		
13	GND	0		GND
14	U OSCC	9.0 9.0		UHF oscillator. Since Pin 14 is an open collector, connect power supply through a choke coil or a resistor of about 500Ω .
15	U OSCB2	3.4 2.8		
16	U OSCB1	3.4 2.8		

Electrical Characteristics

See Electrical Characteristics Test Circuit. ($T_a=25^\circ\text{C}$, $V_{cc}=9\text{V}$)

Item	Symbol	Test conditions	Min.	Typ.	Max.	Unit
Supply current	IccV	VHF operation No signal	33.5	45.0	57.5	mA
	IccU	UHF operation No signal	35.0	46.0	60.0	mA
Conversion gain *1	CG1	VHF operation $f_{RF}=55\text{MHz}$ Input level -40dBm	22.0	25.0	28.0	dB
	CG2	VHF operation $f_{RF}=470\text{MHz}$ Input level -40dBm	22.0	25.0	28.0	dB
	CG3	UHF operation $f_{RF}=470\text{MHz}$ Input level -40dBm	28.5	31.5	34.5	dB
	CG4	UHF operation $f_{RF}=890\text{MHz}$ Input level -40dBm	26.0	29.0	32.0	dB
Noise figure *1	NF1	VHF operation $f_{RF}=55\text{MHz}$		12.0	14.0	dB
	NF2	VHF operation $f_{RF}=470\text{MHz}$		13.5	15.5	dB
	NF3	UHF operation $f_{RF}=470\text{MHz}$		8.5	10.5	dB
	NF4	UHF operation $f_{RF}=890\text{MHz}$		10.5	13.0	dB
1% cross modulation *1 *2	CM1	VHF operation $f_D=55\text{MHz}$ $f_{UD}=\pm 12\text{MHz}$	92.0	95.0		dB μ
	CM2	VHF operation $f_D=470\text{MHz}$ $f_{UD}=\pm 12\text{MHz}$	88.0	91.0		dB μ
	CM3	UHF operation $f_D=470\text{MHz}$ $f_{UD}=\pm 12\text{MHz}$	85.0	88.0		dB μ
	CM4	UHF operation $f_D=890\text{MHz}$ $f_{UD}=\pm 12\text{MHz}$	85.0	88.0		dB μ
Max. output power	Pomax (sat)	50 Ω load	+8.0	+12.0		dBm

*1 Measured value for untuned inputs.

Matching NF (noise figure) results in approximately the below values.

NF2 ($f_{RF}=470\text{MHz}$): 12dB typ. NF4 ($f_{RF}=890\text{MHz}$): 10dB typ.

For VHF the input is unbalanced and for UHF input is balanced.

*2 Optimal reception frequency (f_D) input level is -33dBm

Interrupt frequency (f_{UD}) is 100kHz at 40% AM; Interrupt frequency level when measured with spectrum analyzer at $S/I=46\text{dB}$.

Electrical Characteristics Test Circuit

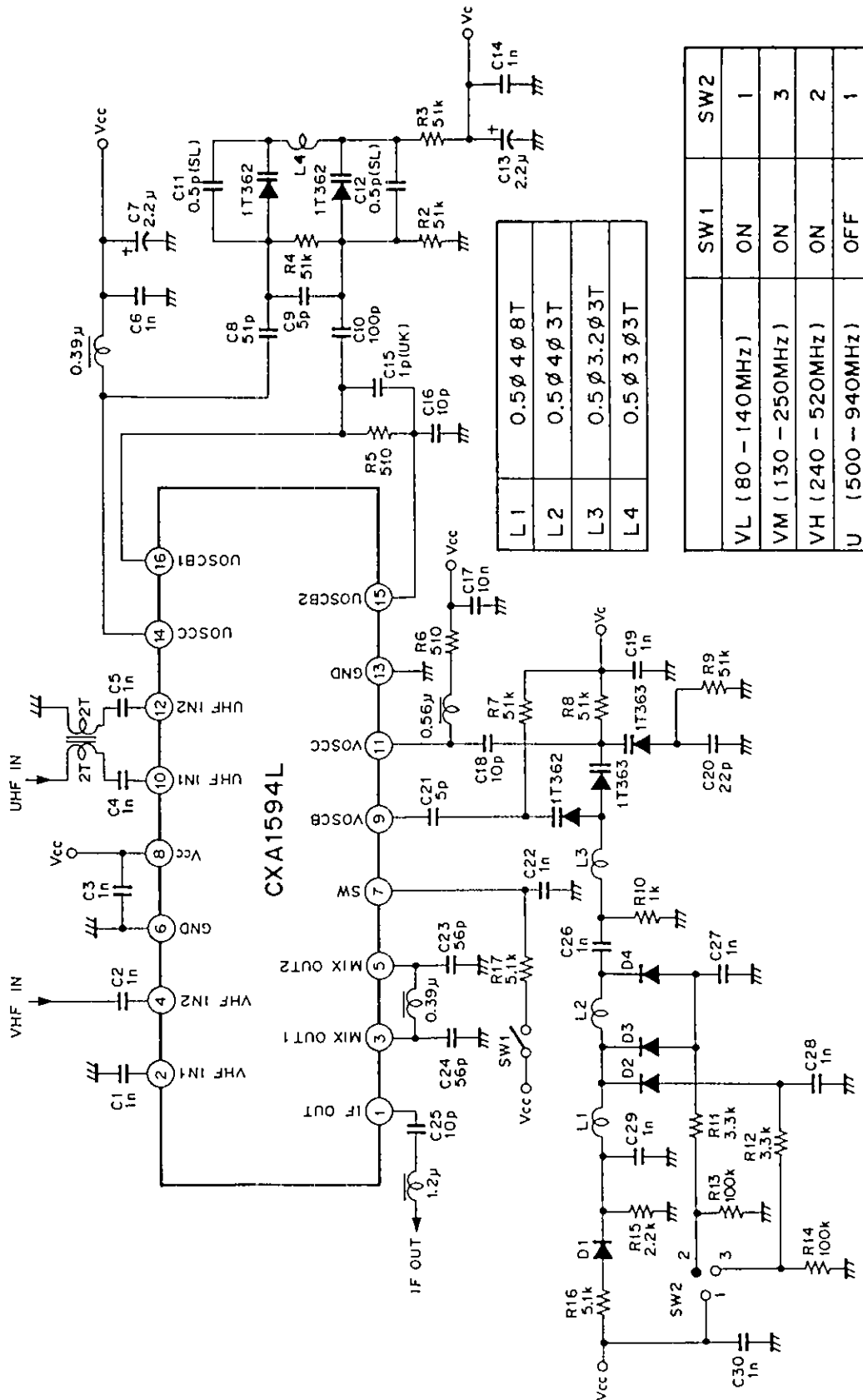

Application Circuit (UM 3 Band Tuner)

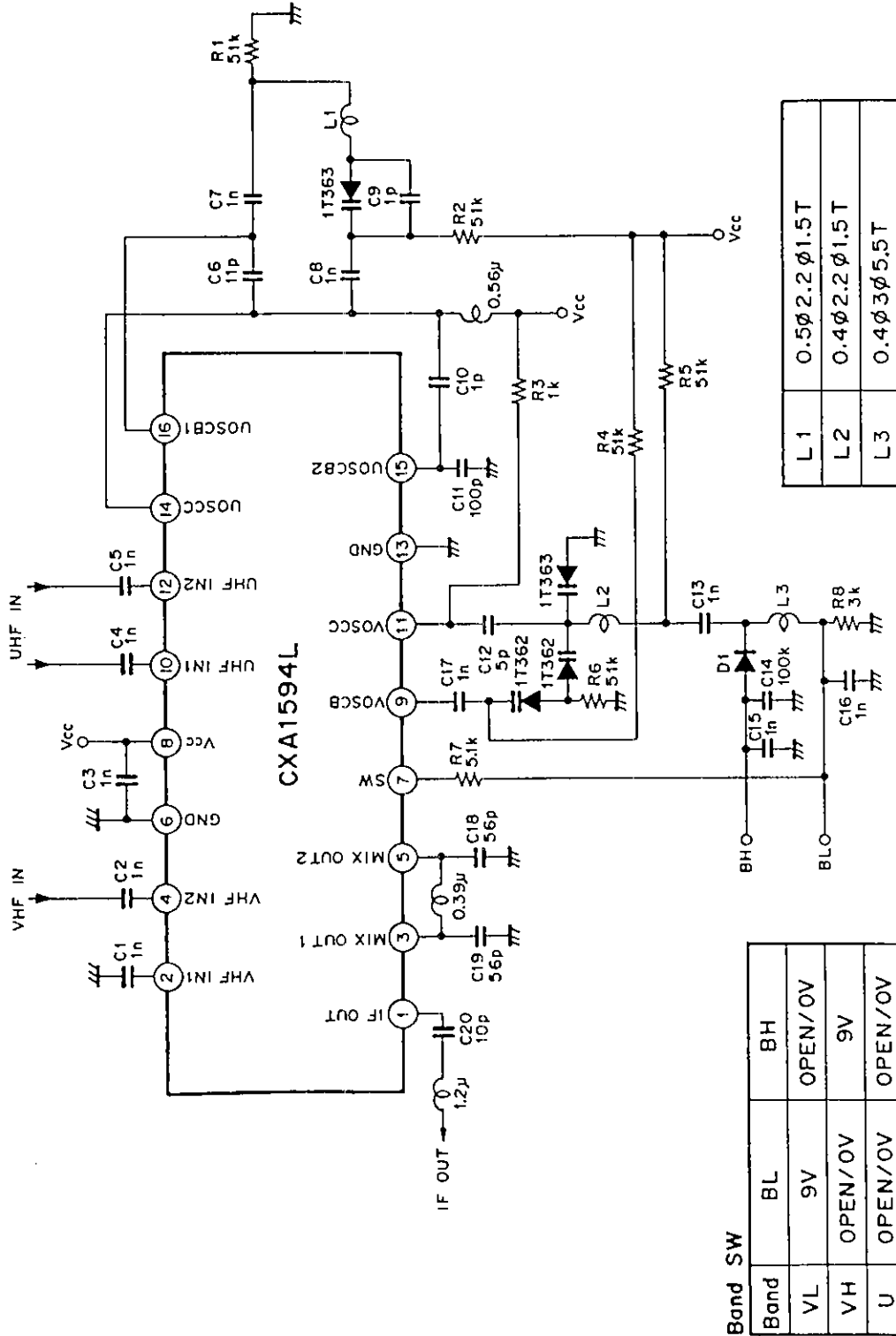

Application circuits shown are typical examples illustrating the operation of the devices. Sony cannot assume responsibility for any problems arising out of the use of these circuits or for any infringement of third party patent and other right due to same.

Description of Operation (See Electrical Characteristics Test Circuit Application Circuit)

(1) VHF Oscillator Circuit

Differential amplifier type oscillator circuit with output at Pin 11 and input at Pin 9.

Provide oscillation through applying positive feedback by inputting Pin 11 output through a combination capacitor followed by an LC resonator circuit and a feedback capacitor to Pin 9. Note that if the parasitic capacitance between Pins 9 and 11 is too large, a positive feedback is returned through the parasitic capacitance and abnormal oscillation may occur.

Since Pin 11 is an open collector, connect the power supply through a choke coil or a resistor rated between 510 and 1k Ω . When using a choke coil, note that parasitic oscillation may occur if Q is too large.

(2) VHF Mixer Circuit

The mixer circuit employs a double balance mixer for reduce local oscillator signal leakage. The RF is input to Pins 2 and 4. For normal use one pin is grounded and the other pin is the RF input. The RF signal is converted to IF signal with the oscillator signal. The input to the IF amplifier is output to Pins 3 and 5 simultaneously.

(3) UHF Oscillator Circuit

UHF oscillator is formed from a differential amplifier just like the VHF oscillator.

Oscillation should be provided at the point between the transistor base and collector at the differential input as shown in the Application Circuit.

Since Pin 14 is an open collector, connect the power supply through a choke coil or a resistor rated between 510 and 1k Ω .

(4) UHF Mixer Circuit

Double balance mixer is same as VHF mixer. The RF signal is input to Pins 10 and 12. The recommended input method is a balanced differential input from pre-stage double tune circuit.

Otherwise, the conditions and usage are the same as for the VHF Mixer Circuit.

(5) IF Amplifier Circuit

The mixer output signal is amplified by the IF amplifier and output to Pin 1. The output impedance is nearly equal 50 Ω .

(6) U/V Switch Circuit

U/V mode is selected by the DC voltage at Pin 7. UHF operation is chosen by OPEN (0V) input and VHF operation by an input of 3V or more. Normally the U/V switch is implemented through the combination of a 5.1k Ω resistor switching between open/9V.

Notes on Operation

Care should be taken in placing external parts because high frequencies are present. Adjust accordingly to prevent heat problems with special care for Pins 6 and 13 (GND) whose heat dissipations accumulate.

Example of Representative Characteristics

Circuit Current vs. Supply Voltage
(VHF operation)

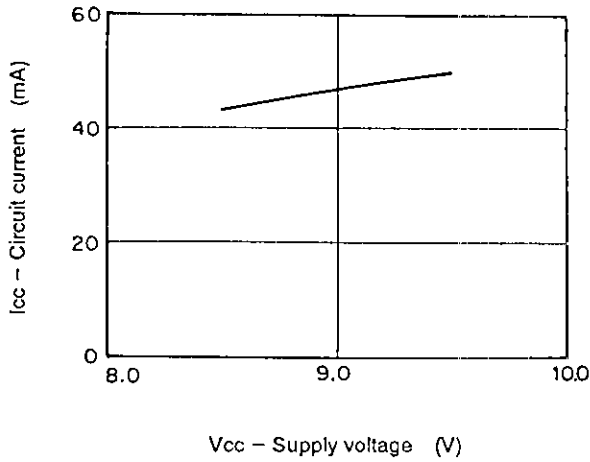

Conversion Gain vs. Reception Frequency
(Untuned Input)
Input level is -40dBm

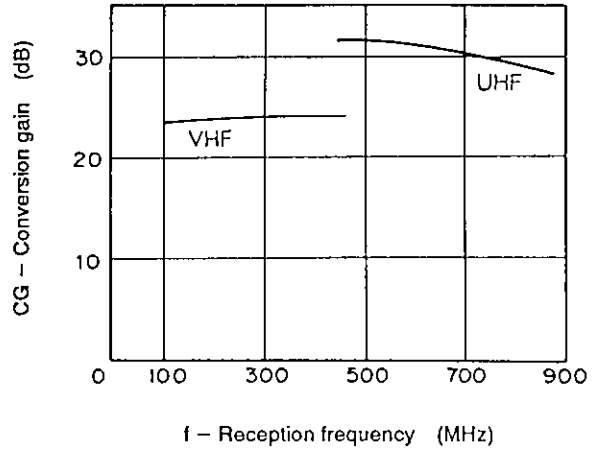

Noise Figure vs. Reception Frequency
(Untuned Input)

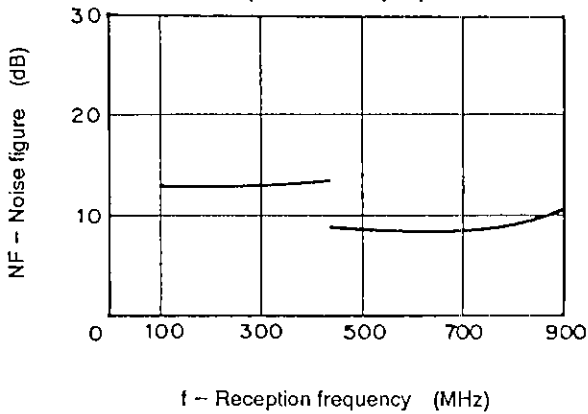

Noise Figure vs. Reception Frequency
(Tuned Input)

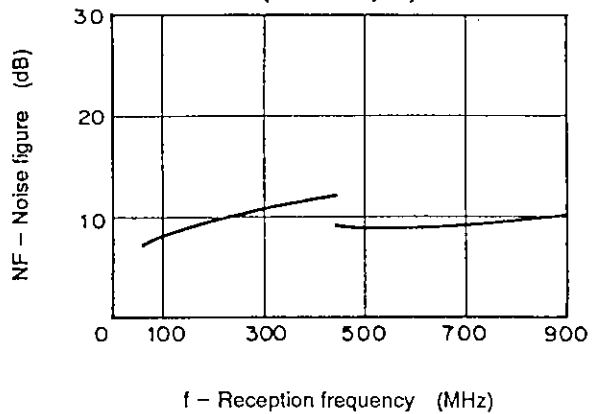

VHF Input Impedance

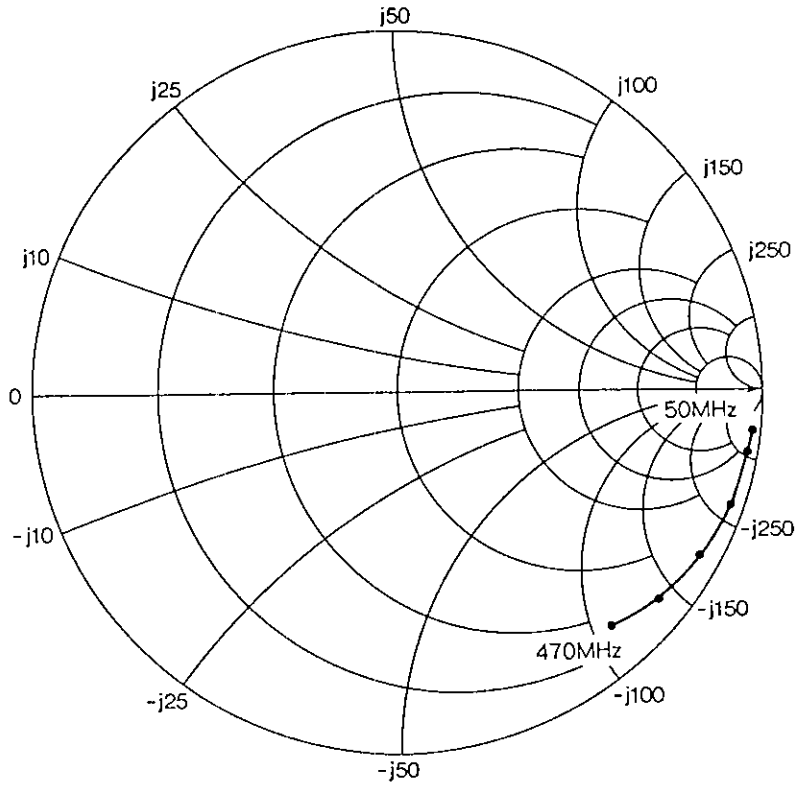

UHF Input Impedance

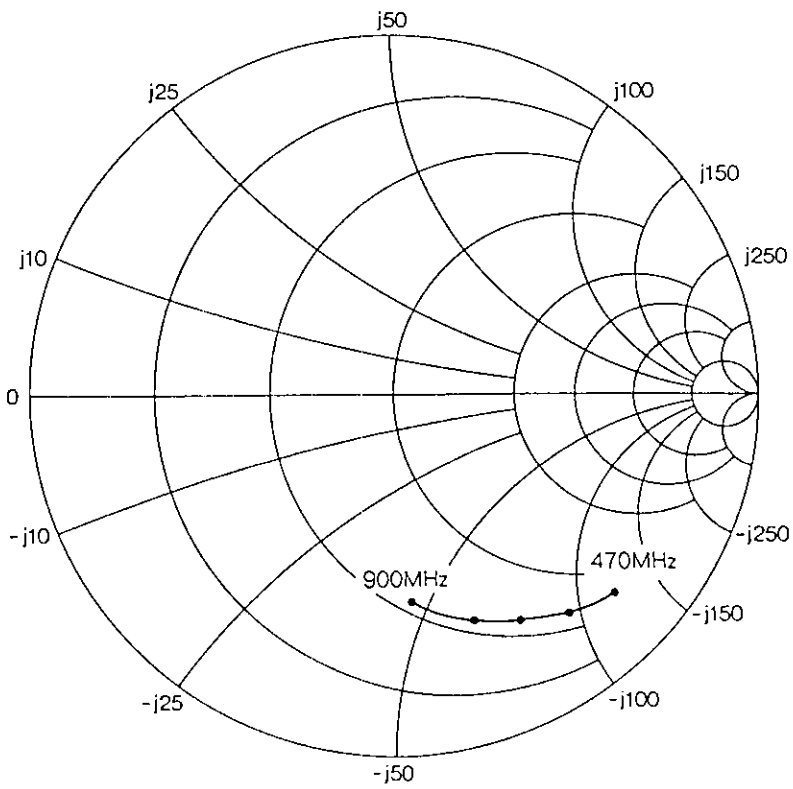

Package Outline Unit : mm

16pin SZIP (Plastic) 225mil

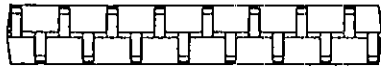
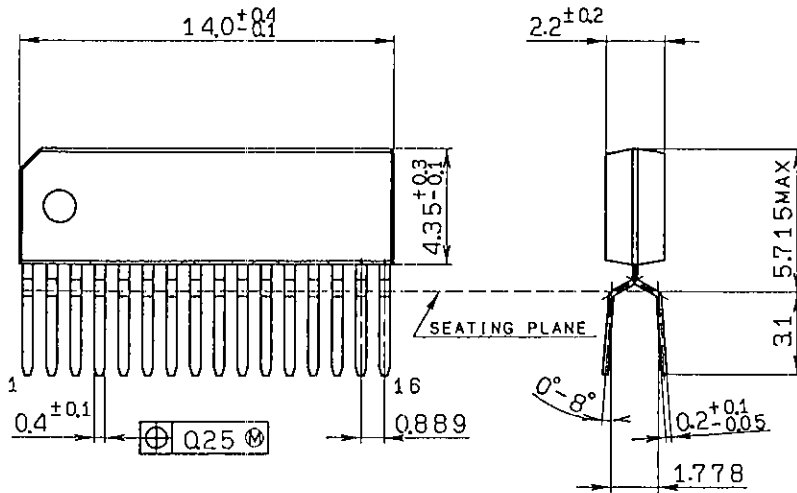

SONY NAME	SZIP-16P-01
EIAJ NAME	SZIP016-P-0225-A
JEDEC CODE	-----