

SONY

CXA1598M/S

Recording Equalizer Amplifier for Stereo Cassette Decks

Description

The CXA1598M/S is a bipolar IC developed for recording equalizer amplifier in analog cassette decks. Incorporating the filter circuit has eliminated the external inductor. Also, each of the six parameters required for equalizer amplifiers can be set independently with external resistance.

Features

- Inductor (coil) is unnecessary
- The six parameters (low frequency gain, medium frequency gain, peaking gain, medium frequency compensation frequency, peaking frequency, and Q) required for recording equalizer amplifiers can be set independently with external resistance
- Low frequency boost is possible with an external capacitor
- Built-in recording mute function (requiring only an external time constant circuit to implement soft mute)
- Built-in 2 channels
- Small package

Applications

Recording equalizer amplifier for stereo analog cassette decks

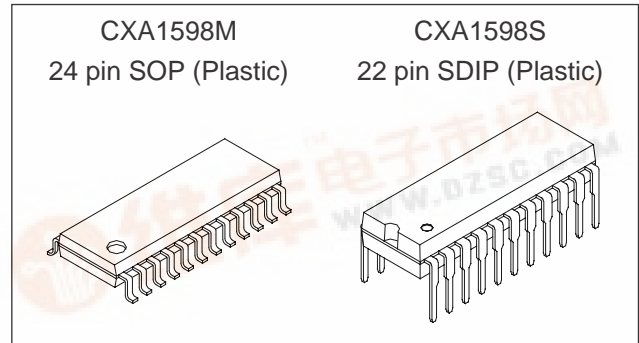

Structure

Bipolar silicon monolithic IC

Absolute Maximum Ratings

- Supply voltage V_{CC} 17 V
- Operating temperature T_{opr} -20 to +75 °C
- Storage temperature T_{stg} -65 to +150 °C
- Allowable power dissipation

P_D (CXA1598M)	570	mW
(CXA1598S)	880	mW

Operating Conditions

- Power supply Dual power supplies ($V_{CC} - V_{EE}$)

	±6.5 to 8.0	V
--	-------------	---
- Single power supply (V_{CC})

	10.0 to 16.0	V
--	--------------	---



Block Diagram and Pin Configuration

CXA1598M

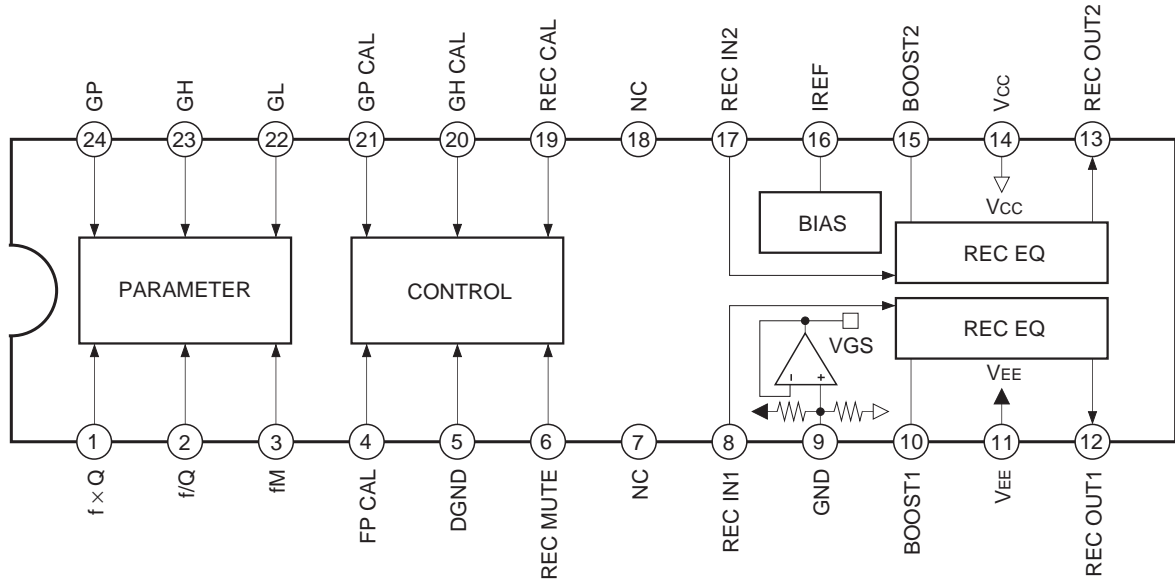

CXA1598S

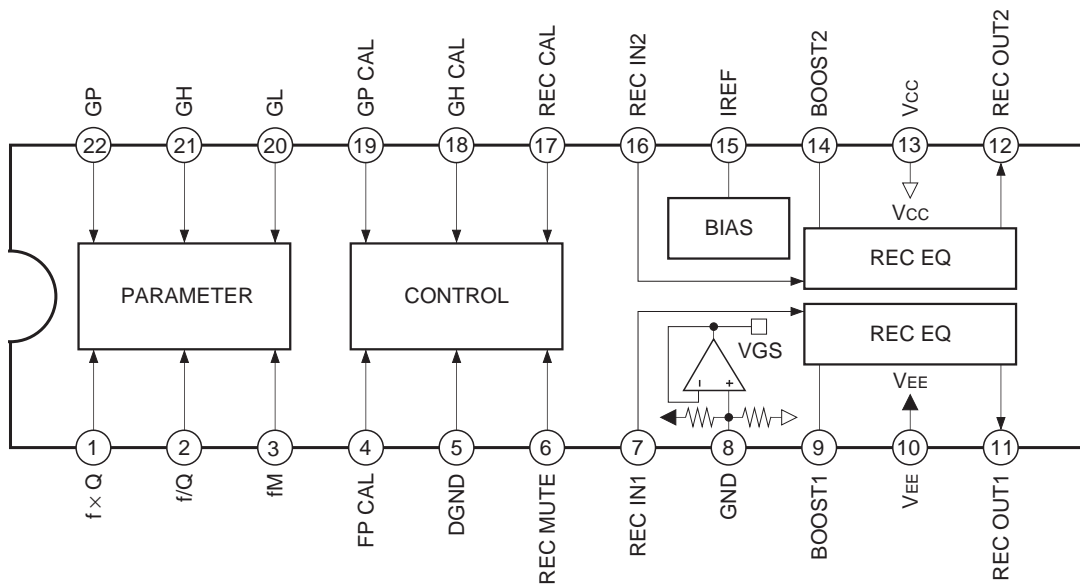

Pin Description

(Ta = 25°C, VCC = 7.0V, VEE = -7.0V)

Pin No.		Symbol	Typical pin voltage		I/O	Z (in)	Equivalent circuit	Description
CXA 1598M	CXA 1598S		DC	AC				
1	1	fxQ	1.2V	—	O	—		<p>Connection pins of resistors for setting the recording equalizer amplifier parameters.</p> <p>* Current input pins used to set the parameters for the recording equalizer amplifier.</p> <p>* Setting currents for each parameter are generated by attaching resistors between these pins and the DGND pin.</p>
2	2	f/Q						
3	3	fM						
22	20	GL						
23	21	GH						
24	22	GP						
4	4	FP CAL	2.5V	—	I	54k		<p>Peaking frequency calibration pin.</p> <p>* Controlled with DC voltages of 0 to 5V. High = Peaking frequency increased Low = Peaking frequency reduced</p> <p>* Leave this pin open when not using the peaking frequency calibration function.</p>
19	17	REC CAL	2.5V	—	I	54k		<p>Recording level calibration pin.</p> <p>* Controlled with DC voltages of 0 to 5V. High = Recording level gain increased Low = Recording level gain reduced</p> <p>* Leave this pin open when not using the recording level calibration function.</p>
5	5	DGND	0.0V	—	I	—		Connected to GND.

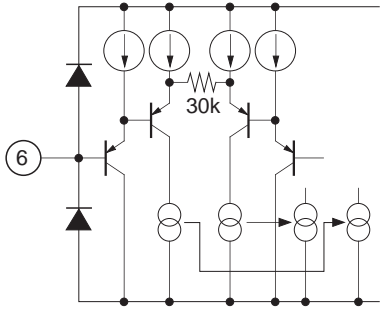
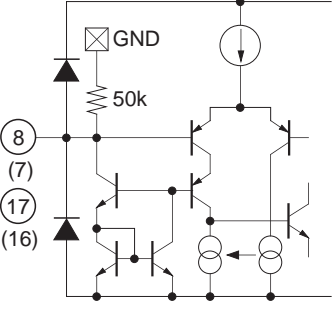
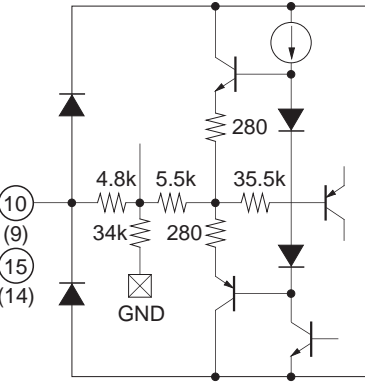
Pin No.		Symbol	Typical pin voltage		I/O	Z (in)	Equivalent circuit	Description
CXA 1598M	CXA 1598S		DC	AC				
6	6	REC MUTE	5.0V	—	I	—		<p>Recording mute ON/OFF selection pin.</p> <p>* Recording mute is controlled with DC voltages of 0 to 5V. High = Recording mute OFF Low = Recording mute ON</p> <p>* Soft mute and fader can be switched over by changing the time constant of the external time constant circuit.</p>
8 17	7 16	REC IN1 REC IN2	0.0V	-18dBv	I	50kΩ		<p>Recording equalizer amplifier input pin.</p>
9	8	GND (VG)	0.0V	—	I	—	<p>Connect to GND for positive/negative dual power supplies. Vcc/2 (center potential) for a single power supply. (Connect a capacitor of 10μF or more)</p>	
10 15	9 14	BOOST1 BOOST2	0.0V	—	I	9.5kΩ		<p>Connection pin of an external capacitor for low frequency boost.</p> <p>* When low frequency boost is unnecessary, connect to GND for positive/negative dual power supplies; connect a capacitor (3.3μF or more) for a single power supply.</p>

Pin No.		Symbol	Typical pin voltage		I/O	Z (in)	Equivalent circuit	Description
CXA 1598M	CXA 1598S		DC	AC				
11	10	V _{EE}	-7.0V	—	I	—		Connect to the negative power supply for positive/negative dual power supplies. Connect to GND for a single power supply.
12 13	11 12	REC OUT1 REC OUT2	0.0V	-3.0dBv	O	—		Recording equalizer amplifier output pin.
14	13	V _{CC}	7.0V	—	I	—		Positive power supply connection pin.
16	15	IREF	1.2V	—	O	—		Reference current setting pin for monolithic filter. * The reference current can be set by attaching a resistor between this pin and DGND.

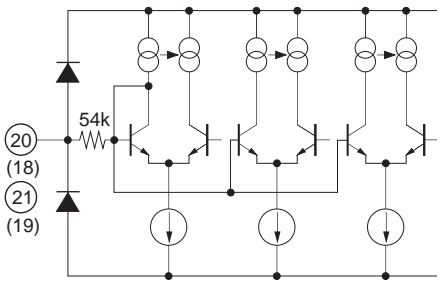
Pin No.		Symbol	Typical pin voltage		I/O	Z (in)	Equivalent circuit	Description
CXA 1598M	CXA 1598S		DC	AC				
20	18	GH CAL	2.5V	—	I	—		<p>Medium frequency calibration pin.</p> <p>* Controlled with DC voltages of 0 to 5V. High = Medium frequency level gain increased Low = Medium frequency level gain reduced</p> <p>* Leave this pin open when not using the medium frequency calibration function.</p>
21	19	GP CAL	2.5V	—	I	—		<p>High frequency calibration pin.</p> <p>* Controlled with DC voltages of 0 to 5V. High = High frequency level gain increased Low = High frequency level gain reduced</p> <p>* Leave this pin open when not using the high frequency calibration function.</p>

Electrical Characteristics

(Ta = 25°C, VCC = 7.0V, VEE = -7.0V)

Item		Conditions	Min.	Typ.	Max.	Unit
Entire LSI	Current consumption (Icc)	Standard settings RGL: 36k//510k, RGH: 62k//220k, RGP: 36k//110k, RfM: 39k//910k, Rf/Q: 47k//750k, RfxQ: 47k//620k	10.0	13.6	17.4	mA
	Operating voltage range 1 (positive/negative dual power supplies)		±6.5	±7.0	±8.0	V
	Operating voltage range 2 (single power supply)		10.0	14.0	16.0	V
Recording equalizer amplifier	Recording reference output level	Recording equalizer amplifier reference output level (315Hz) (This output level is the tape reference 0dB which generates magnetic flux of 250nWb/m.)	—	-3.0	—	dBv
	Recording reference input level	Input level when the reference output level is 315Hz, -3.0dBv (For measurement, input a 315Hz, -18.0dBv signal to the REC IN pins and then measure the output level.)	-19.8	-18.3	-16.8	dBv
	Signal handling (1kHz, THD = 1%, RL = 2.7kΩ)	Input a 1kHz signal and set the output so that THD (total harmonic distortion) is 1%. RL = 2.7kΩ (Measure the distortion of a +11dB level-up signal.)	11.0	11.5	—	dB
	Total harmonic distortion (1kHz, 0.0dB, RL = 2.7kΩ)	Input a 1kHz, 0.0dB (reference input level) signal and measure the distortion. RL = 2.7kΩ (Measure the distortion as THD + N.)	—	0.12	0.6	%
	S/N ratio ("A"-WGT filter)	With no signal, measure the noise using the "A"-WGT filter. Rg = 5.1kΩ (The measured value is indicated as the relative value compared to the reference level.)	57.0	65.0	—	dB
	Output DC offset voltage (REC OUT pin)	With no signal, measure the DC offset voltage of the REC OUT pin.	-500	0	500	mV
	Mute characteristics 1 (REC-MUTE = 0.5V)	REC-MUTE = 0.5V (Use a 1kHz BPF.) Input a 1kHz signal (+12dB level up) and measure the attenuation when REC MUTE is on.	—	-100	-80	dB
	Mute characteristics 2 (REC-MUTE = 2.5V)	REC-MUTE = 2.5V Input a 1kHz, 0.0dB (reference level) signal and measure the attenuation characteristics of the soft mute function.	-6.0	-4.5	-3.0	dB
	REC-CAL characteristics 1 (REC-CAL = 5.0V)	REC-CAL = 5.0V Input a 315Hz signal (-20dB level down) and measure the amount of change compared to when the REC-CAL function is at the standard setting.	5.0	6.0	7.0	dB
	REC-CAL characteristics 2 (REC-CAL = 0.0V)	REC-CAL = 0.0V Input a 315Hz signal (-20dB level down) and measure the amount of change compared to when the REC-CAL function is at the standard setting.	-7.5	-6.5	-5.5	dB

Item		Conditions	Min.	Typ.	Max.	Unit
Recording equalizer amplifier	GH-CAL characteristics 1 (GH-CAL = 5.0V)	GH-CAL = 5.0V RGH: 62k//220k, RGL • RGP: OPEN RfM: 300k, Rf/Q: 18k, RfxQ: 12k Input a 6.3kHz signal (–20dB level down) and measure the amount of change compared to when the GH-CAL function is at the standard setting.	4.7	5.7	6.7	dB
	GH-CAL characteristics 2 (GH-CAL = 0.0V)	GH-CAL = 0.0V RGH: 62k//220k, RGL • RGP: OPEN RfM: 300k, Rf/Q: 18k, RfxQ: 12k Input a 6.3kHz signal (–20dB level down) and measure the amount of change compared to when the GH-CAL function is at the standard setting.	–5.5	–4.5	–3.5	dB
	GP-CAL characteristics 1 (GP-CAL = 5.0V)	GP-CAL = 5.0V RGP: 36k//110k, RGL • RGH: OPEN RfM: 300k, Rf/Q: 47k//750k, RfxQ: 47k//620k Input a signal (–20dB level down) and measure the amount of change compared to when the GP-CAL function is at the standard setting.	3.9	5.4	6.9	dB
	GP-CAL characteristics 2 (GP-CAL = 0.0V)	GP-CAL = 0.0V RGP: 36k//110k, RGL • RGH: OPEN RfM: 300k, Rf/Q: 47k//750k, RfxQ: 47k//620k Input a signal (–20dB level down) and measure the amount of change compared to when the GP-CAL function is at the standard setting.	–5.8	–4.3	–2.8	dB
	FP-CAL characteristics 1 (FP-CAL = 5.0V)	FP-CAL = 5.0V Input a signal (–20dB level down) and measure the amount of change compared to when the FP-CAL function is at the standard setting.	185	200	215	%
	FP-CAL characteristics 2 (FP-CAL = 0.0V)	FP-CAL = 0.0V Input a signal (–20dB level down) and measure the amount of change compared to when the FP-CAL function is at the standard setting.	36	46	56	%
	fM medium frequency compensation frequency variable width		0.3	2.4	10	kHz
	fp peaking frequency variable width		10	17.8	50	kHz
	Peaking Q variable width		2	4.2	7	
	GL low frequency gain variable width		–5	0	8	dB
	GH medium frequency gain variable width		–10	–3	11	dB
	GP peaking gain variable width		10	20.5	30	dB
	fM medium frequency compensation frequency deviation	RGL: 36k//510k, RGH • RGP: OPEN or RGH: 62k//220k, RGL • RGP: OPEN RfM: 39k//910k, Rf/Q: 18k, RfxQ: 12k	–15	0	15	%
	fp peaking frequency deviation	RGP: 36k//110k, RGL • RGH: OPEN RfM: 300k, Rf/Q: 47k//750k, RfxQ: 47k//620k	–15	0	15	%

Item		Conditions	Min.	Typ.	Max.	Unit
Recording equalizer amplifier	Peaking Q deviation	RGP: 36k//110k, RGL • RGH: OPEN RfM: 300k, Rf/Q: 47k//750k, RfxQ: 47k//620k	-20	0	20	%
	GL low frequency gain deviation	RGP: 36k//510k, RGH • RGP: OPEN RfM: 9.1k, Rf/Q: 18k, RfxQ: 12k	-0.5	0	0.5	dB
	GH medium frequency gain deviation	RGH: 62k//220k, RGL • RGP: OPEN RfM: 300k, Rf/Q: 18k, RfxQ: 12k	-0.8	0	0.8	dB
	GP peaking gain deviation	RGP: 36k//110k, RGL • RGH: OPEN RfM: 300k, Rf/Q: 47k//750k, RfxQ: 47k//620k	-2.0	0	2.0	dB
	Input impedance	Pins 8 and 17 (CXA1598M) Pins 7 and 16 (CXA1598S)	40	50	60	kΩ

Note: Unless otherwise specified, RGL, RGH, RGP, RfM, Rf/Q, and RfxQ settings are the characteristics when set to the standard settings.

Electrical Characteristics Measurement Circuit (CXA1598S)

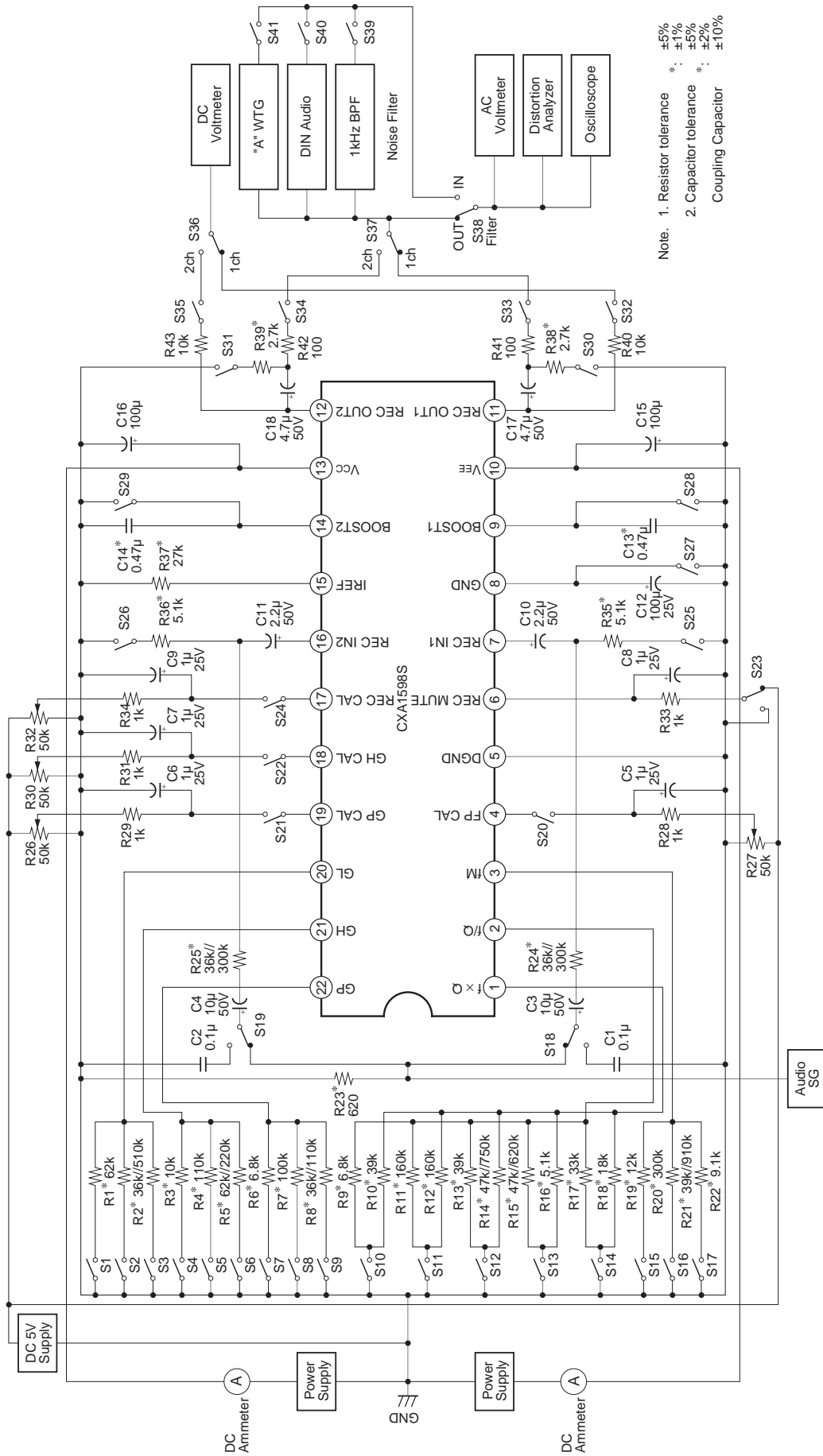

Note. 1. Resistor tolerance : ±5%
 * : ±1%
 ±5%
 2. Capacitor tolerance : ±2%
 * : ±10%
 Coupling Capacitor

Electrical Characteristics Measurement Circuit (CXA1598M)

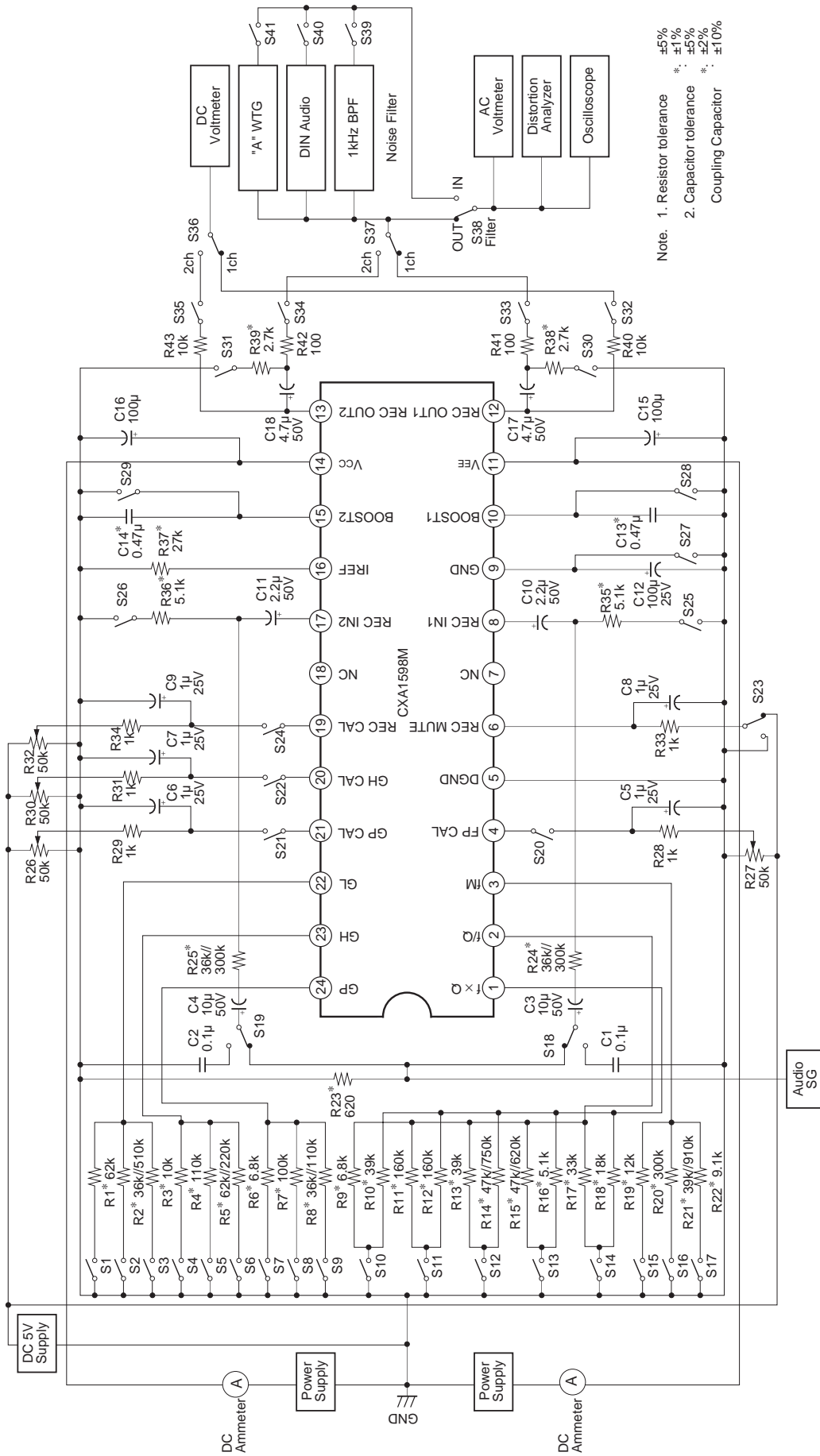

Note. 1. Resistor tolerance ±5%
 * : ±1%
 2. Capacitor tolerance ±5%
 * : ±2%
 Coupling Capacitor : ±10%

Application Circuit for Positive/Negative Dual Power Supplies (CXA1598S)

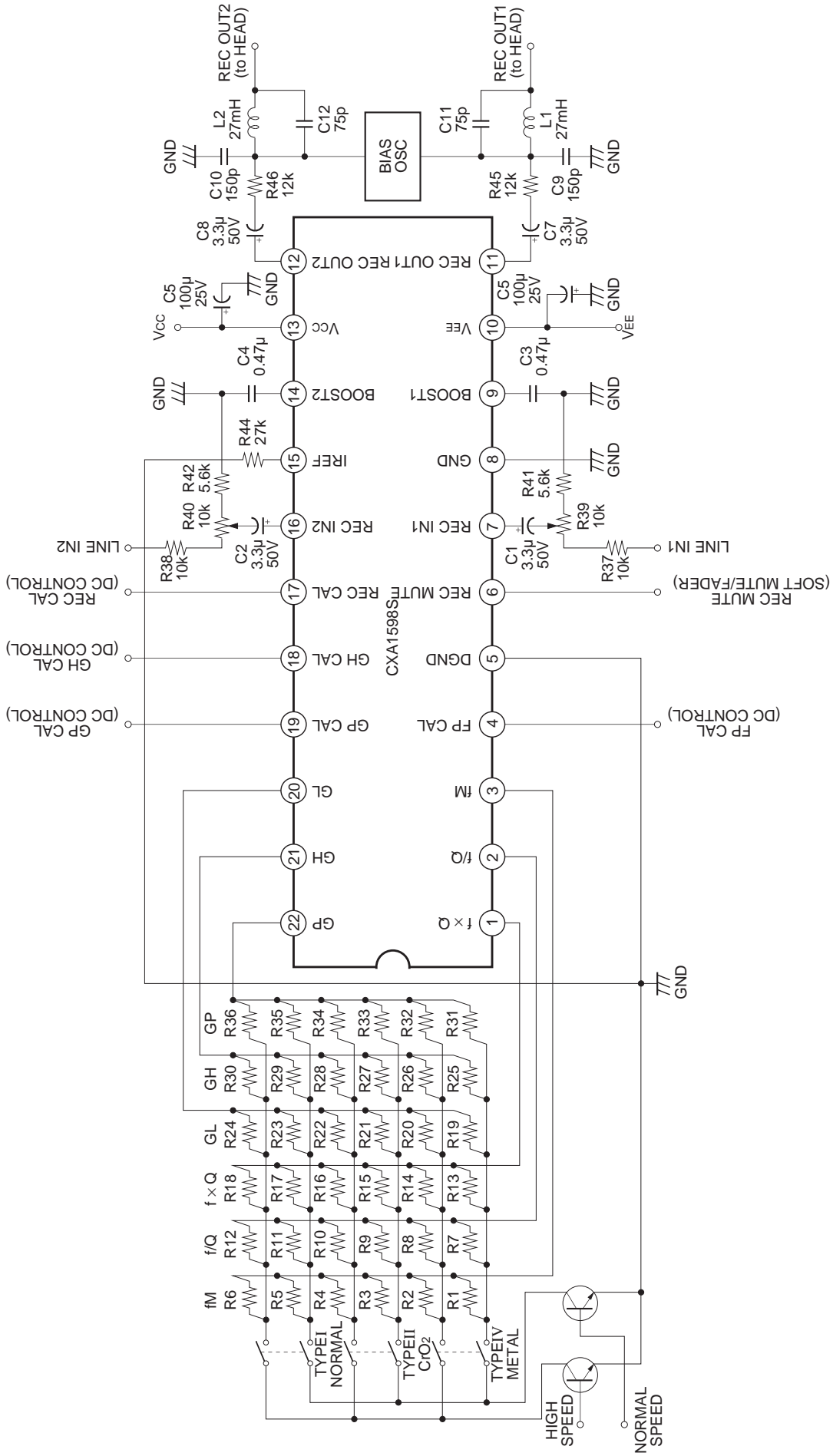

Application circuits shown are typical examples illustrating the operation of the devices. Sony cannot assume responsibility for any problems arising out of the use of these circuits or for any infringement of third party patent and other right due to same.

Application Circuit for Positive/Negative Dual Power Supplies (CXA1598M)

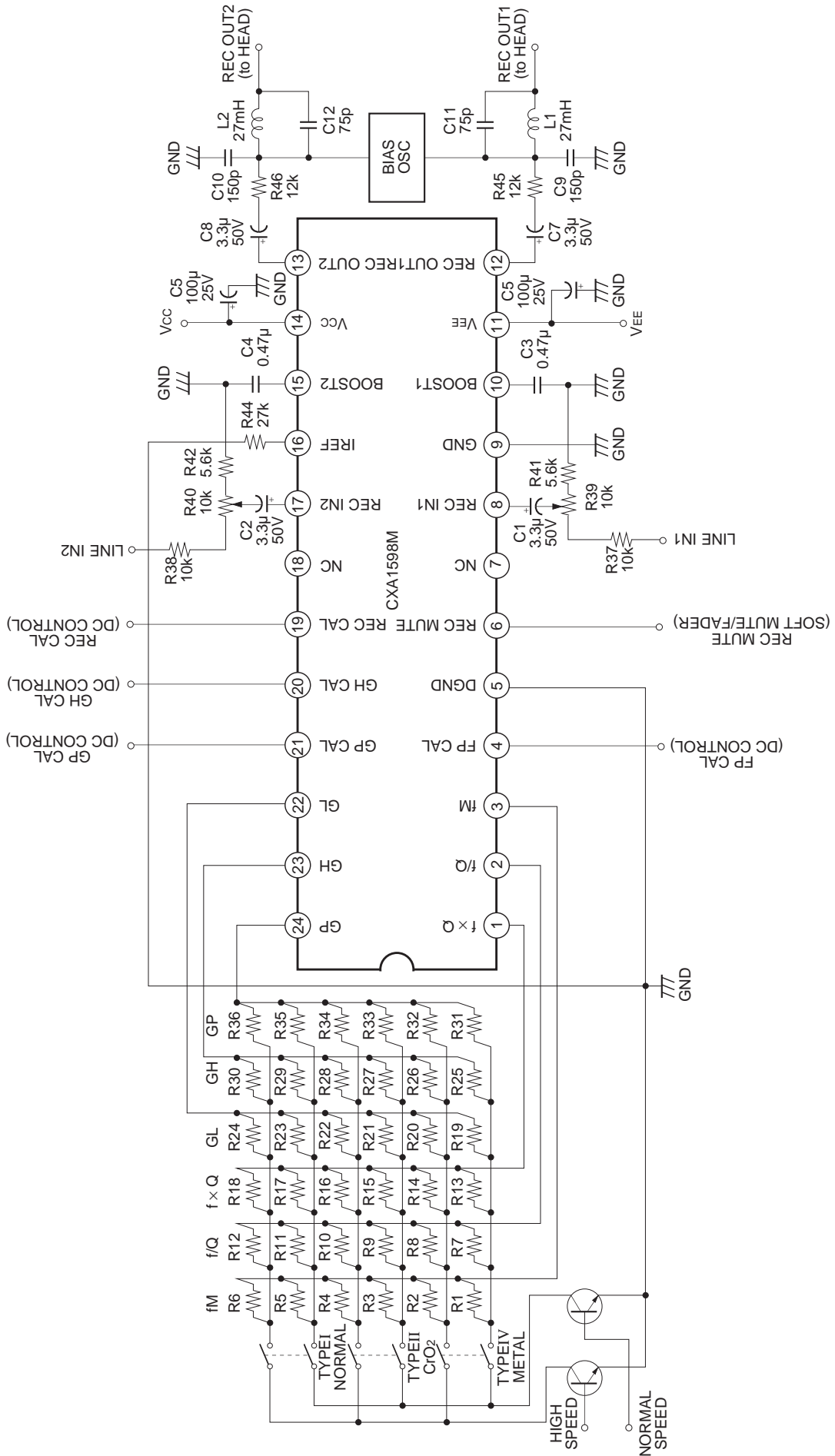

Application circuits shown are typical examples illustrating the operation of the devices. Sony cannot assume responsibility for any problems arising out of the use of these circuits or for any infringement of third party patent and other right due to same.

Application Circuit for a Single Power Supply (CXA1598S)

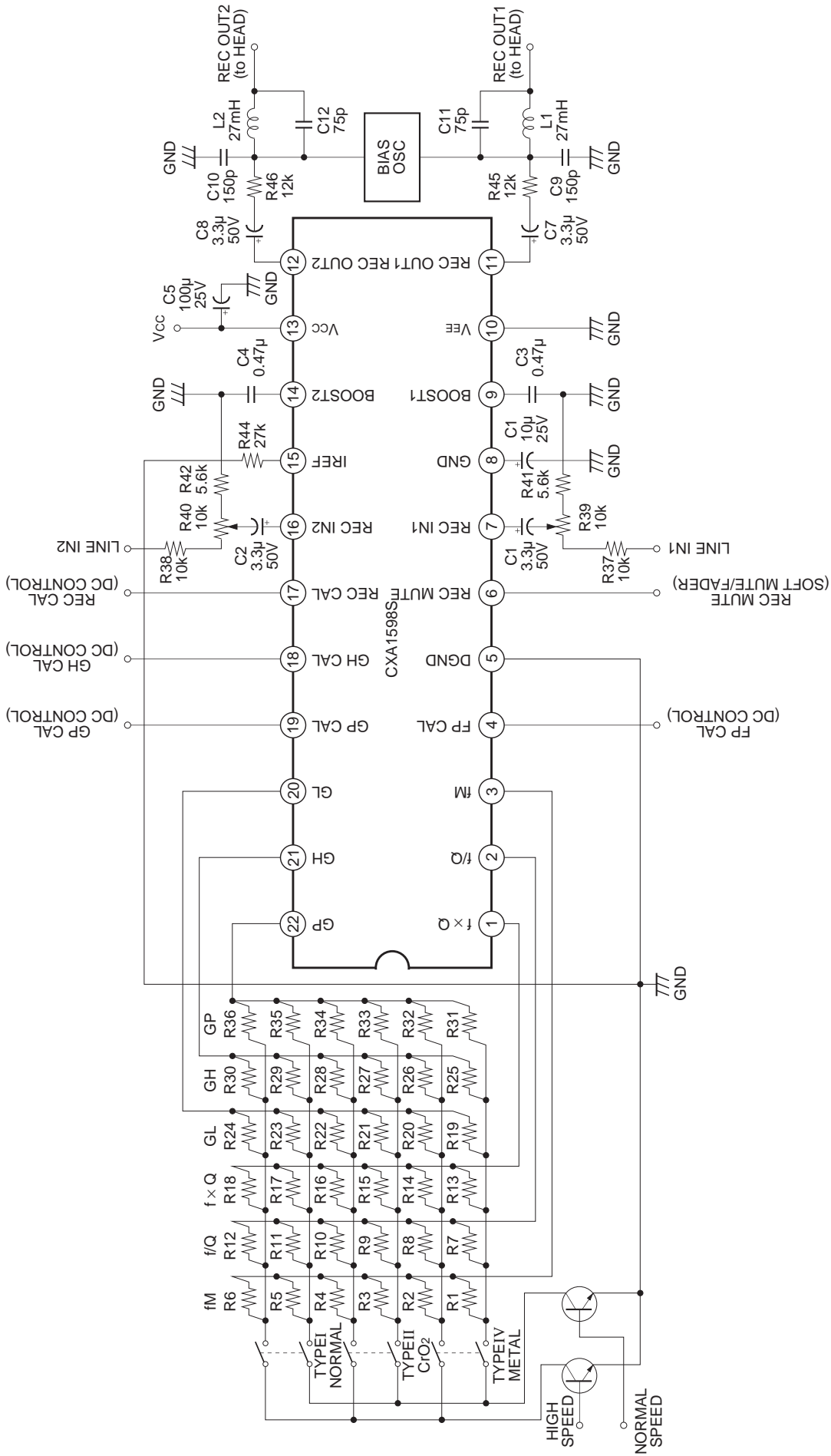

Application circuits shown are typical examples illustrating the operation of the devices. Sony cannot assume responsibility for any problems arising out of the use of these circuits or for any infringement of third party patent and other right due to same.

Application Circuit for a Single Power Supply (CXA1598M)

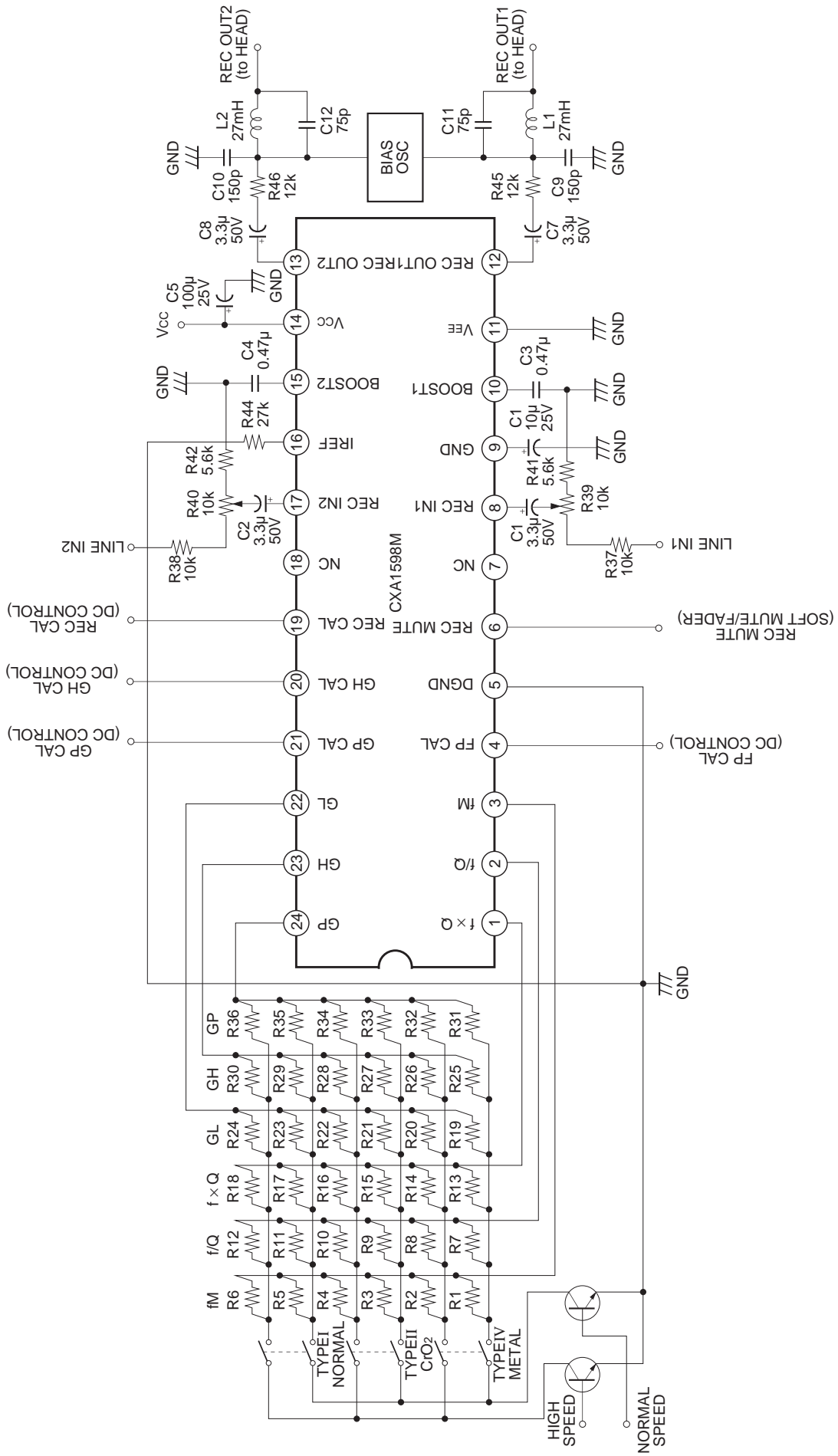

Application circuits shown are typical examples illustrating the operation of the devices. Sony cannot assume responsibility for any problems arising out of the use of these circuits or for any infringement of third party patent and other right due to same.

Description of Operation

1. Recording equalizer amplifier

The primary features of the CXA1598 recording equalizer amplifier are that by taking full advantage of monolithic filter technology, an LC resonance circuit consisting of a coil and capacitor normally required for high frequency compensation is dispensed with and medium and low frequency sensitivity compensation is performed with its internal filter alone. In addition, the six parameters (low frequency gain, medium frequency gain, peaking gain, medium frequency compensation frequency, peaking frequency, and Q) required for recording equalizer amplifiers can be set as desired simply by attaching resistors to the GL, GH, GP, fM, f/Q, and fxQ pins.

This IC has the circuit configuration shown in Fig. 1 to provide the optimum frequency response required for recording equalizer amplifiers.

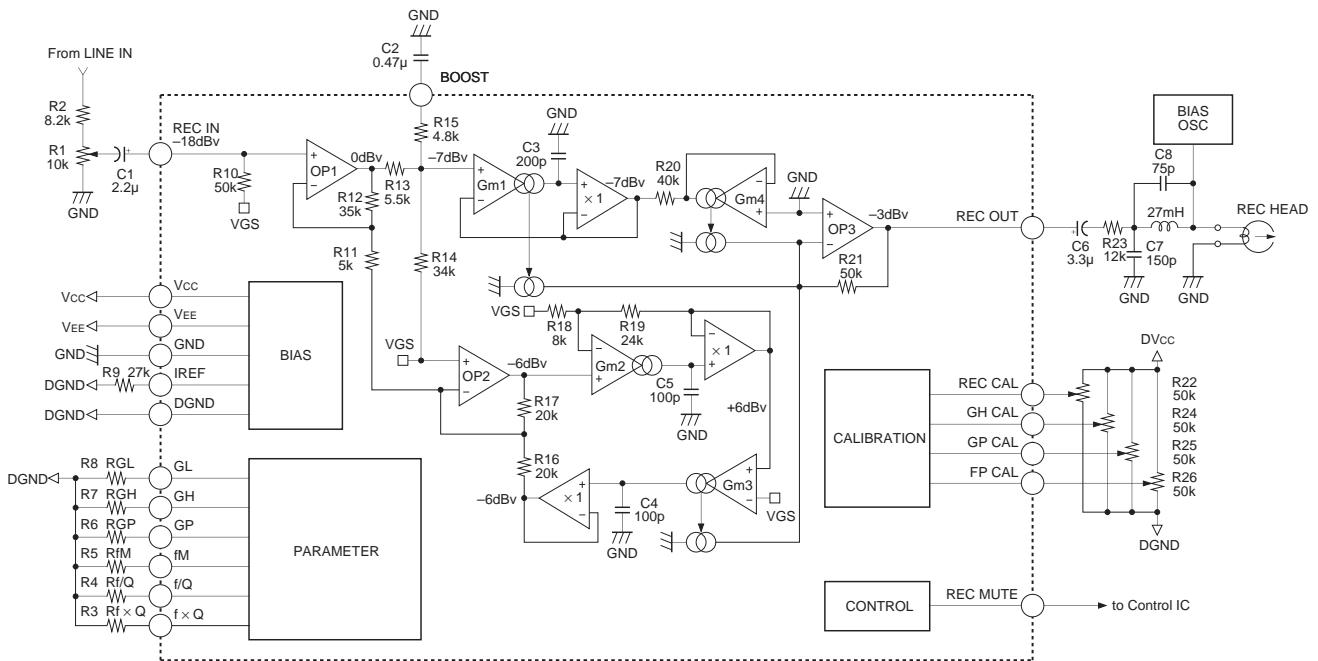

Fig. 1. CXA1598M/S functional circuit block diagram

2. Low frequency boost

The CXA1598 implements low frequency boost simply by attaching an external capacitor to the BOOST pins. Signals are boosted by approximately 6dB. The boost cut-off frequency can be freely set with the value of the external capacitor.

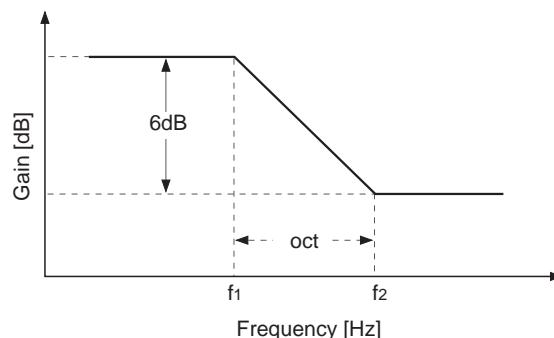

Fig. 2. CXA1598M/S low frequency boost frequency response

3. Recording mute function

The CXA1598 contains a built-in recording mute circuit which varies the recording equalizer amplifier gain according to the magnitude of the DC voltage applied to the REC MUTE pin just like an electronic volume control. Also, any desired soft mute or fader can be freely set depending on momentary changes in the DC voltage applied to the REC MUTE pin. Fig. 3 illustrates the recording mute waveforms.

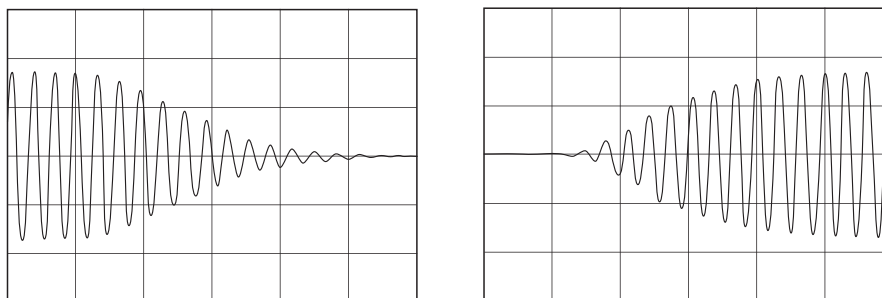

Fig. 3. Recording mute waveform

4. Recording level calibration function

The CXA1598 allows the recording level to be finely adjusted with a DC voltage. The recording equalizer amplifier gain can be varied by approximately ± 5 dB simply by applying a DC voltage to the REC CAL pin. When not using the recording level calibration function, simply leave the REC CAL pin open, and the REC CAL pin is matched to the internal reference voltage (2.5V), with the recording level set for the standard output gain.

5. Medium frequency equalizer amplifier calibration function

The CXA1598 allows the medium frequency equalizer amplifier characteristics to be finely adjusted with a DC voltage. By simply applying a DC voltage to the GH CAL pin, the medium frequency equalizer amplifier gain can be varied by approximately ± 4 dB. When not using this calibration function, simply leave the GH CAL pin open, and the GH CAL pin is matched to the internal reference voltage (2.5V), with the medium frequency equalizer amplifier characteristics set for the standard output gain.

6. High frequency equalizer amplifier calibration function

The CXA1598 allows the high frequency equalizer amplifier characteristics to be finely adjusted with a DC voltage. By simply applying a DC voltage to the GP CAL pin, the high frequency equalizer amplifier gain can be varied by approximately ± 4 dB. Also, when not using this calibration function, simply leave the GP CAL pin open, and the GP CAL pin is matched to the internal reference voltage (2.5V), with the high frequency equalizer amplifier characteristics set for the standard output gain.

7. fp peaking frequency calibration function

The CXA1598 allows the fp peaking frequency to be finely adjusted with a DC voltage. By simply applying a DC voltage to the FP CAL pin, the fp peaking frequency can be varied by approximately 46% to 200%. Also, when not using this calibration function, simply leave the FP CAL pin open, and the FP CAL pin is matched to the internal reference voltage (2.5V), with the fp peaking frequency response set for the standard fp peaking frequency.

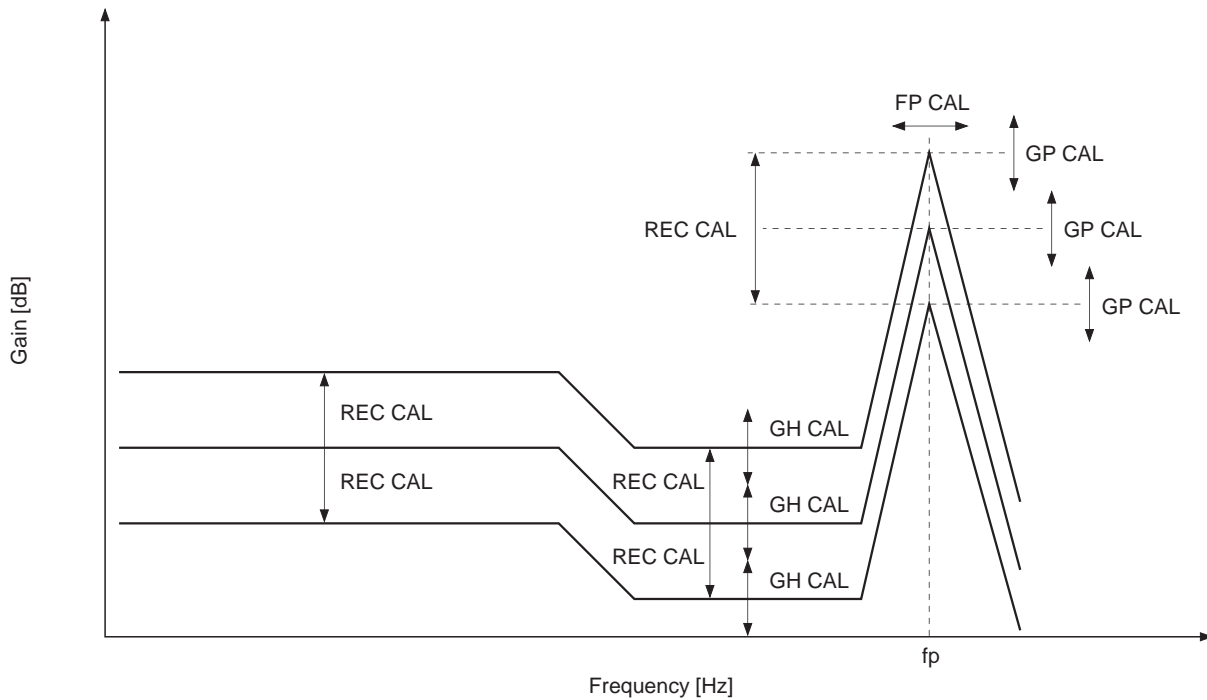

Fig. 4. Conceptual diagram of recording level/medium frequency equalizer amplifier/high frequency equalizer amplifier/fp peaking frequency calibration functions

Control Voltage for Each Control Pin

Pin NO.	Pin Name	Pin voltage [V], referenced to DGND					Remarks
		0.0	0.5	2.5	4.5	5.0	
4 (4)	FP CAL	Reduce <<<<<<<< Increase					Amount of fp peaking frequency change [%] compared to when FP CAL is at the standard setting.
		46	—	—	—	200	
6 (6)	REC MUTE	Reduce <<<<<<<< Increase					REC OUT attenuation [dB] compared to when REC MUTE is at the standard setting. f = 1kHz
		—	-100	-4.5	—	—	
17 (19)	REC CAL	Reduce <<<<<<<< Increase					Amount of change [dB] compared to when REC CAL is at the standard setting. f = 315Hz
		-6.5	—	—	—	6.0	
18 (20)	GH CAL	Reduce <<<<<<<< Increase					Amount of GH medium frequency gain change [dB] compared to RGH standard. RGL, RGP: OPEN
		-4.5	—	—	—	5.7	
19 (21)	GP CAL	Reduce <<<<<<<< Increase					Amount of GP peaking frequency gain change [dB] compared to RGP standard. RGL, RGH: OPEN
		-4.2	—	—	—	5.4	

8. Mode control methods

Refer to the application circuits shown in Figs. 5 and 6 for mode control methods using a manual switch. When tape mode is implemented with logic, use the same ground for the 27kΩ resistance connected to the common pin (analog switch connection) of the used analog switch IC and to the DGND and IREF pins. Figs. 5 and 6 show examples when using the 4051B (8-channel multiplexer/demultiplexer).

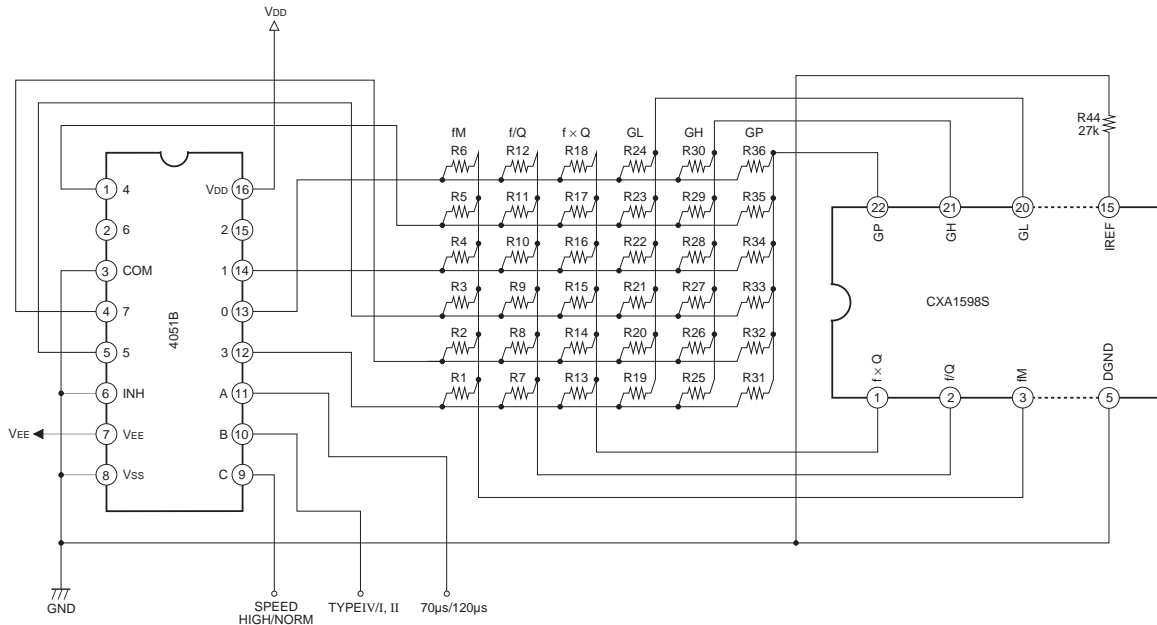

Fig. 5. For positive/negative dual power supplies

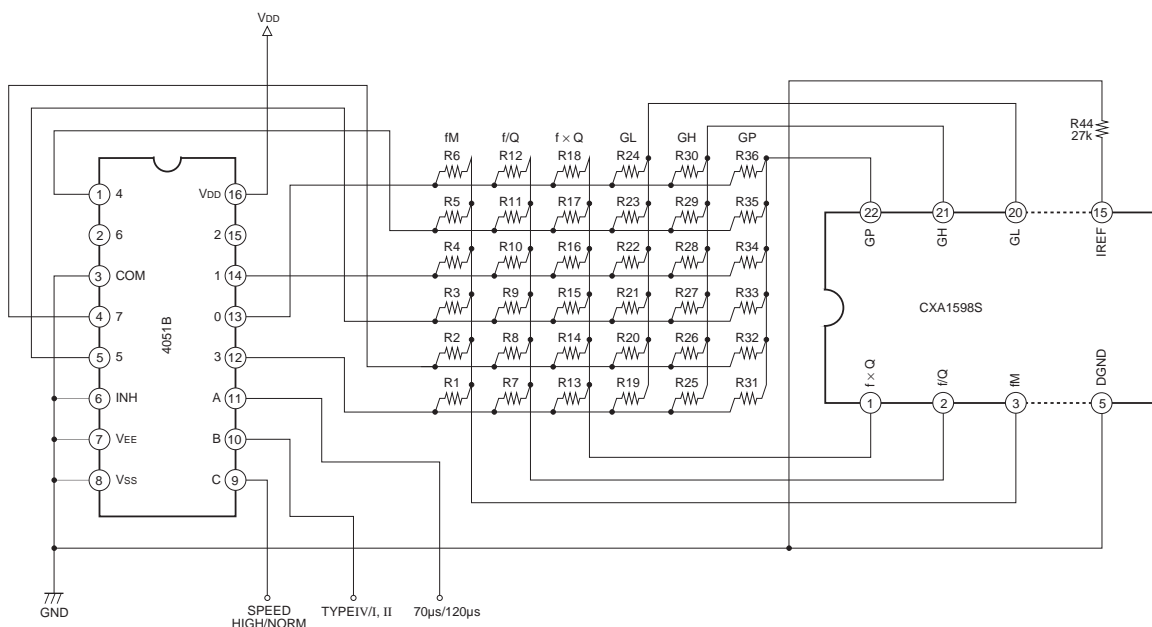

Fig. 6. For a single power supply

9. Temperature characteristics and accuracy of the recording equalizer amplifier

The temperature and cut-off frequency of the CXA1598 depend on the external resistance connected to the IREF, GL, GH, GP, fM, f/Q, and f×Q pins. For low frequency boost, however, the cut-off frequency becomes uneven depending on the temperature characteristics or unevenness of the internal resistance since its time constant is configured by the product of an external capacitor and the internal resistance.

Also, the recording equalizer amplifier frequency response depends on unevenness in the absolute, as well as relative values of the internal capacitance. Furthermore, the high frequency response indicates a high element sensitivity at the filter because the band-pass filter Q is high. Compared to low frequency, although the unevenness inherent in the IC is more likely to occur, this occurs relatively, and not individually for channels 1 and 2.

Notes on Operation

1. Power supply

The CXA1598 is designed basically for positive/negative dual power supplies, and can also operate with a single power supply. Connect the power supplies for each case as shown below:

	Vcc 14pin (13pin)	VEE 11pin (10pin)	GND 9pin (8pin)	DGND 5pin (5pin)
Positive/negative dual power supplies	Positive power supply	Negative power supply	GND	GND
Single power supply	Power supply	GND	—*	GND

Pin Nos. in parentheses are those for the CXA1598S.

* For a single power supply, connect a decoupling capacitor (10μF or more) to the GND (VG) pin. The ripple rejection ratio depends on the capacitance of this capacitor.

2. Low frequency boost

The CXA1598 can implement low frequency boost simply by connecting a capacitor to the BOOST pins. Although the boost is fixed to 6dB, the time constant which determines the cut-off frequency can be set to any desired value depending on the external capacitor. The pole (f₁) and zero (f₂) shown in Fig. 3. Low frequency boost frequency response can be expressed, with the external capacitor assumed to be C_B, as follows:

$$\begin{aligned}
 f_1 &= \frac{R_{13} + R_{14}}{2\pi \cdot C_B \cdot (R_{13} \cdot R_{14} + R_{14} \cdot R_{15} + R_{15} \cdot R_{13})} \\
 &= \frac{1}{2\pi \cdot C_B \cdot (R_{13} \cdot R_{14} / (R_{13} + R_{14}) + R_{15})} = \frac{1}{2\pi \cdot C_B \cdot (9.53k\Omega)} \text{ [Hz]} \\
 &= \frac{1}{2\pi \cdot C_B \cdot R_{15}} = \frac{1}{2\pi \cdot C_B \cdot (4.8k\Omega)} \text{ [Hz]}
 \end{aligned}$$

When not using low frequency boost, follow the procedure described below.

◎ For positive/negative dual power supplies

Connect the BOOST pins to GND.

◎ For single power supply

Connect a fairly large capacitor (3.3μF or more) to the BOOST pins or simply leave the BOOST pins open. If the BOOST pins are left open, note that the output level increases by 6dB, so the input level should be set 6dB down. The CXA1598 is basically designed for positive/negative dual power supplies and the BOOST pins cannot be easily connected to GND as in the case of positive/negative dual power supplies.

3. Resistance connected to the IREF pin as well as the GL, GH, GP, fM, f/Q, and fxQ pins

The recording equalizer amplifier frequency response is determined by the resistance connected to the IREF pin as well as the GL, GH, GP, fM, f/Q, and fxQ pins. This means that the accuracy of the recording equalizer amplifier frequency response is determined by the resistance connected to these pins. Therefore, the resistors used for this purpose must be free of unevenness and have excellent temperature characteristics (e.g., a metallic film resistor).

Example of Representative Characteristics

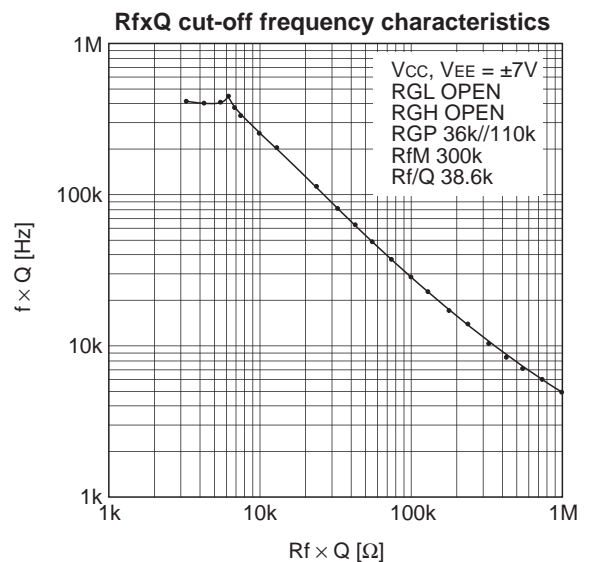
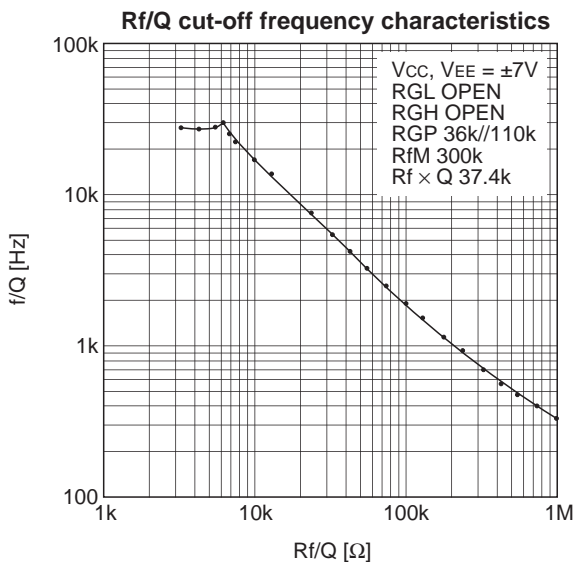
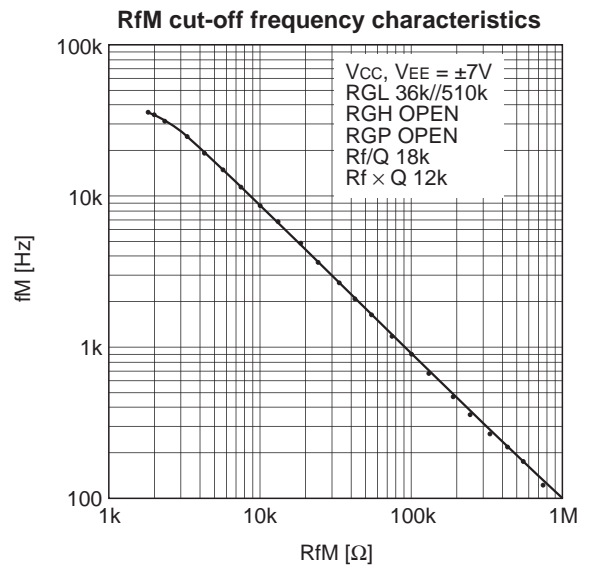
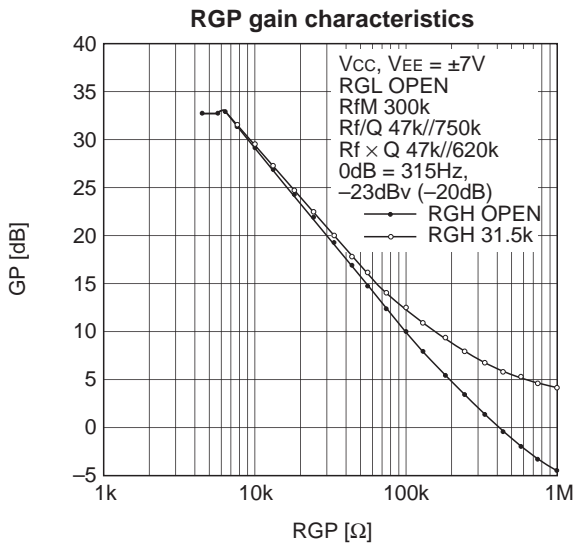
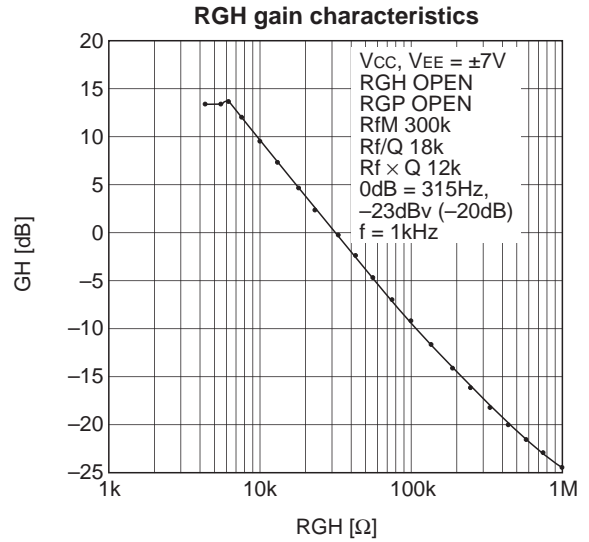
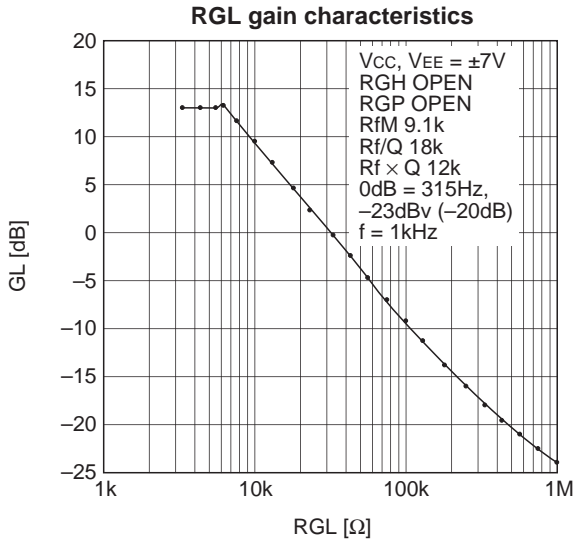

Output level vs. Mute characteristics 1

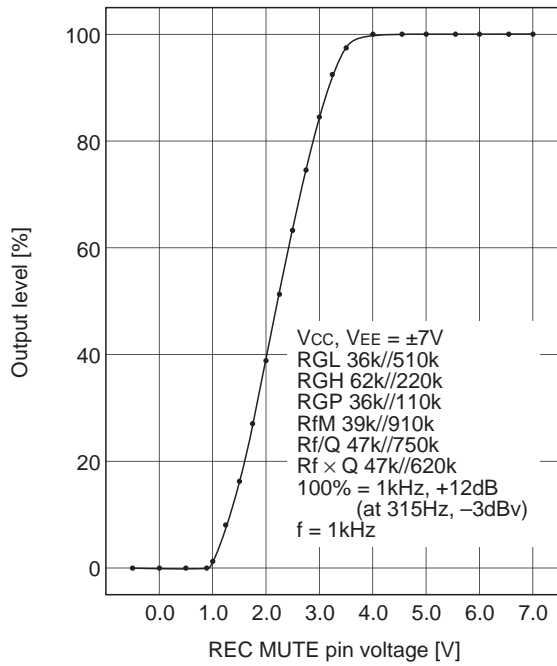

Current consumption vs. Supply voltage

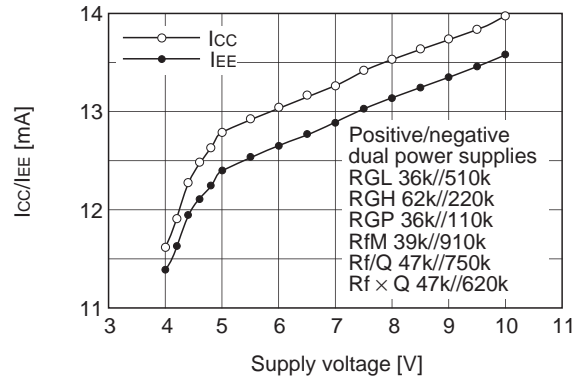

Output level vs. Mute characteristics 2

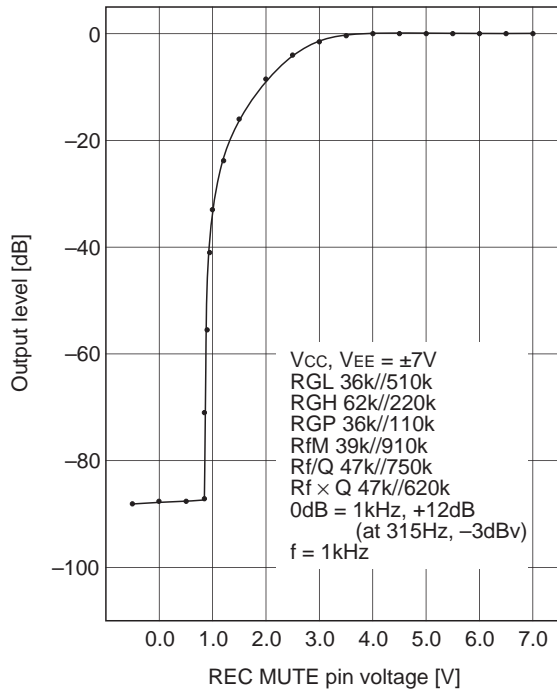

Output level vs. Mute characteristics 3

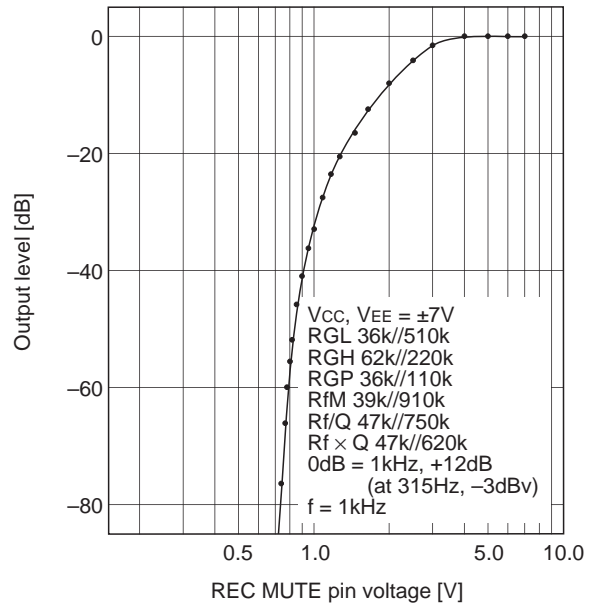

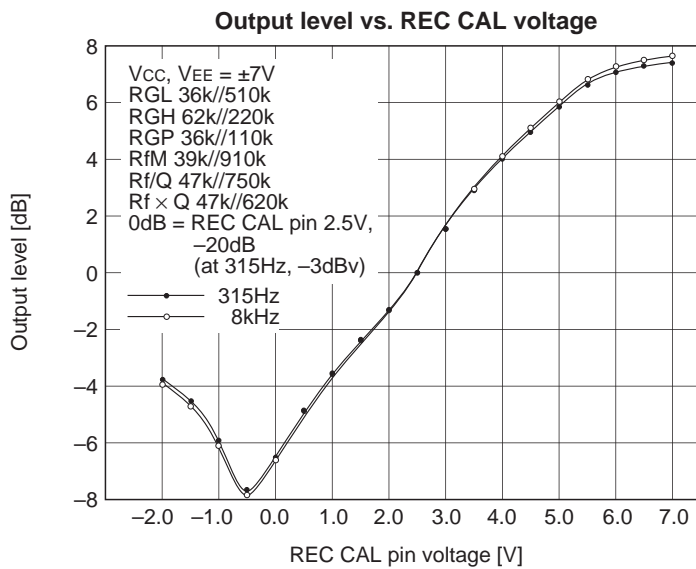
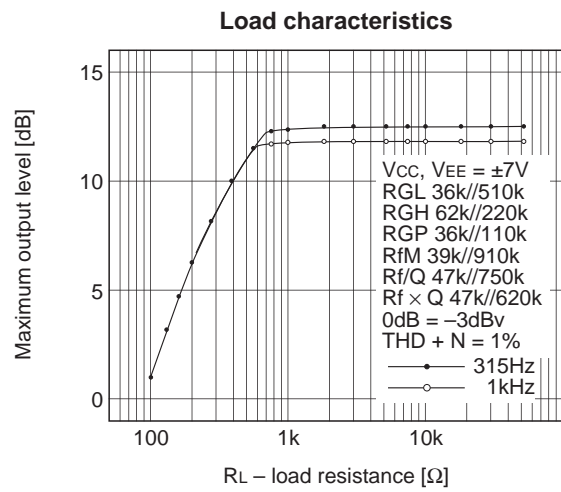
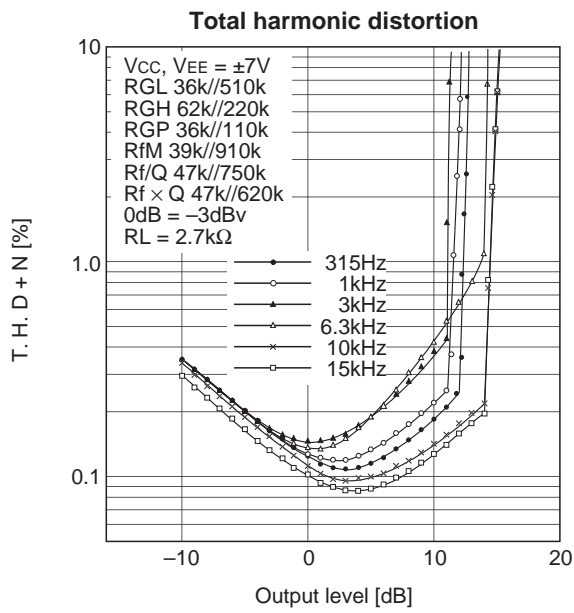

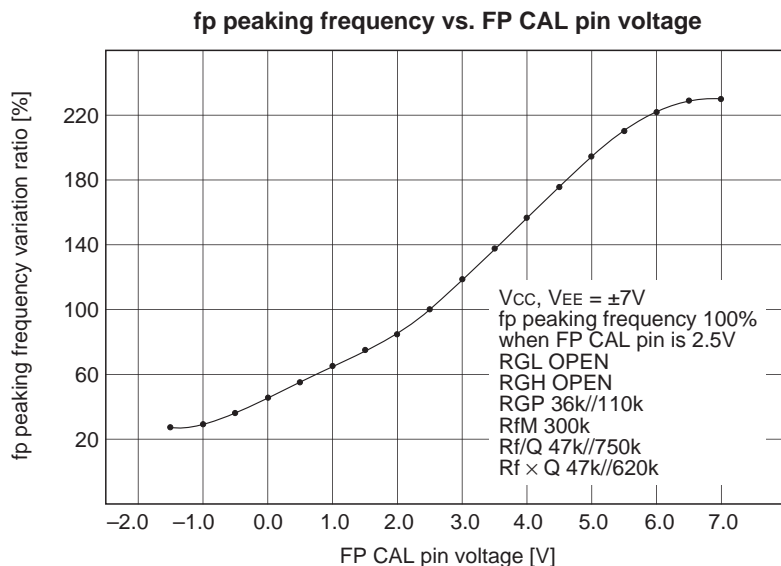
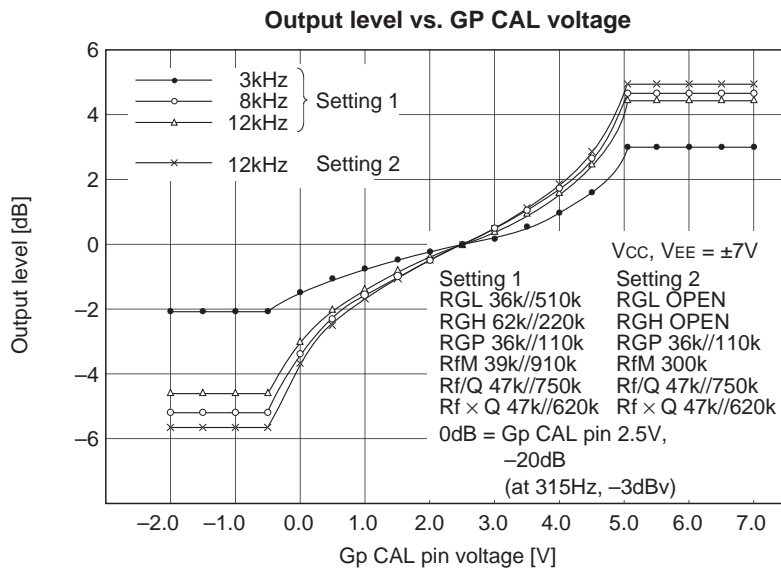
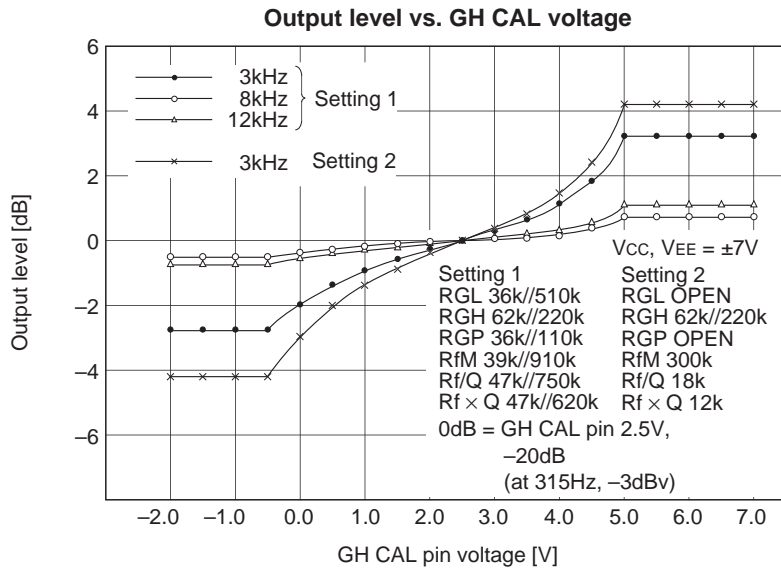

REC CAL and GH CAL frequency response

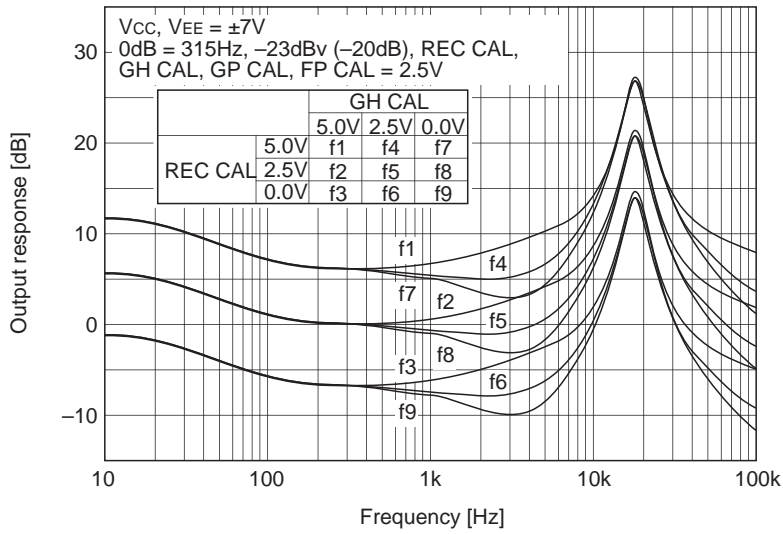

REC CAL and GP CAL frequency response

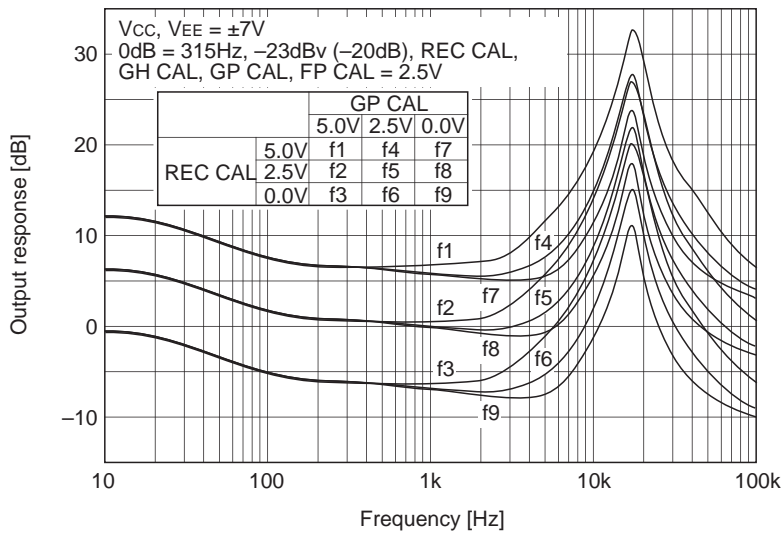

REC CAL and FP CAL frequency response

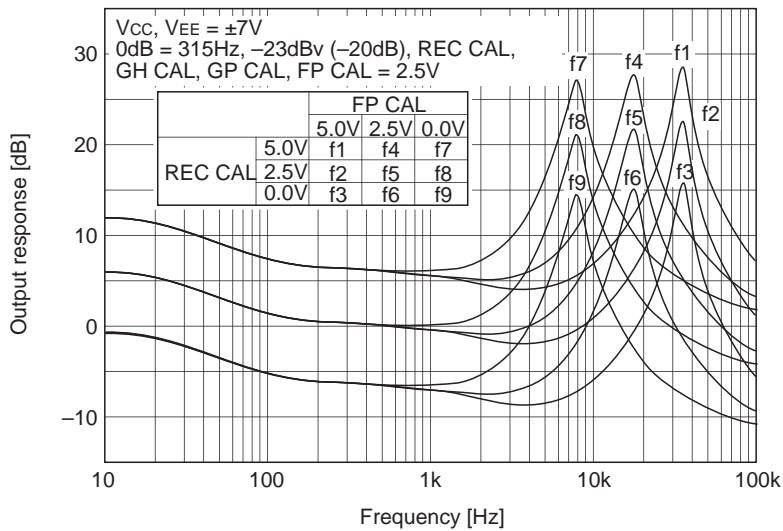

Package Outline Unit: mm

CXA1598M

24PIN SOP (PLASTIC)

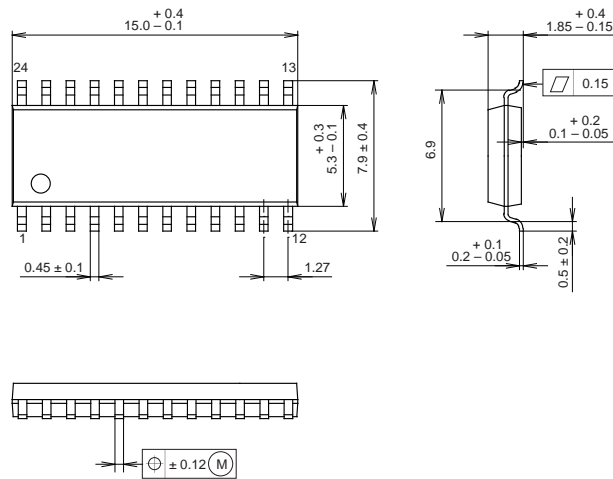

SONY CODE	SOP-24P-L01
EIAJ CODE	*SOP024-P-0300-A
JEDEC CODE	—————

PACKAGE STRUCTURE

MOLDING COMPOUND	EPOXY/PHENOL RESIN
LEAD TREATMENT	SOLDER PLATING
LEAD MATERIAL	COPPER ALLOY / 42ALLOY
PACKAGE WEIGHT	0.3g

CXA1598S

22PIN SDIP (PLASTIC)

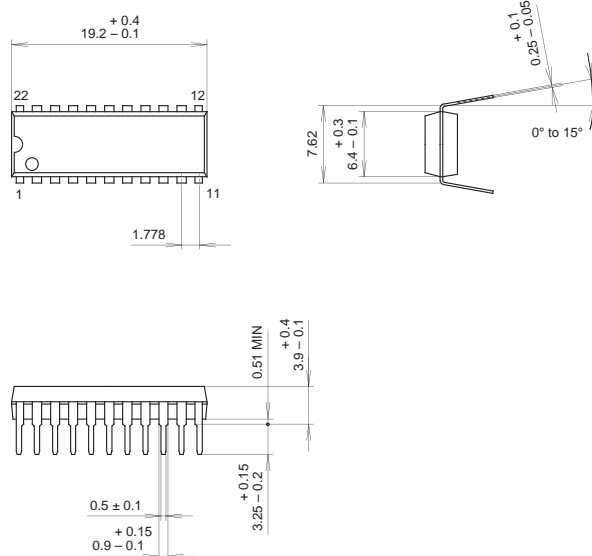

SONY CODE	SDIP-22P-01
EIAJ CODE	SDIP022-P-0300
JEDEC CODE	—————

PACKAGE STRUCTURE

MOLDING COMPOUND	EPOXY RESIN
LEAD TREATMENT	SOLDER PLATING
LEAD MATERIAL	COPPER ALLOY
PACKAGE WEIGHT	0.95g