

SONY

CXA1599Q

1-chip Cassette Deck

Description

The CXA1599Q is an IC for audio cassette decks. All analog signal processing functions, except Dolby NR, are incorporated in a single chip. As a result, a double cassette deck system can be simply configured by adding a Dolby IC.

Features

- Electronic recording volume for setting recording level (with a balance volume)
- Recording equalizer amplifier (with calibration and low frequency boost functions)
- Recording mute function (soft mute and fader possible)
- Playback head amplifier switch function (deck A/B switch)
- NR pass amplifier (NR IN/PASS switch)
- Headphone amplifier with electronic volume
- Full-wave rectifier output amplifier for level meter (with time constant function)
- HPF amplifier for AMS (with BS/AMS gain switch function)
- Electronic switch for tape EQ selection (120 μ s/70 μ s)
- Electronic switch for metal tape selection
- Electronic switch for normal/double speed dubbing selection (only for recording equalizer)
- Line mute function
- Double cassette dubbing system can be easily configured with this single IC.

48 pin QFP (Plastic)

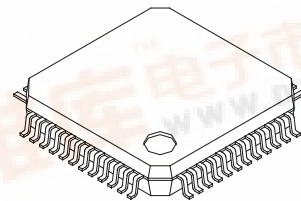

Applications

Analog signal processing (except Dolby NR) for stereo analog cassette deck (ALPS ELECTRIC CO., LTD. HADKH-55460 head applicable)

Structure

Bipolar silicon monolithic IC

Absolute Maximum Ratings (Ta = 25°C)

- | | | | |
|-------------------------------|------------------|-------------|----|
| • Supply voltage | V _{cc} | 17 | V |
| • Operating temperature | T _{opr} | -20 to +75 | °C |
| • Storage temperature | T _{stg} | -65 to +150 | °C |
| • Allowable power dissipation | P _d | 735 | mW |

Operating Conditions

- | | | | |
|---------------------------------------|-----------------|--------------|---|
| Supply voltage | V _{cc} | ±5.0 to ±8.0 | V |
| (positive/negative dual power supply) | | | |
| | | 10.0 to 16.0 | V |
| (single power supply) | | | |



Block Diagram

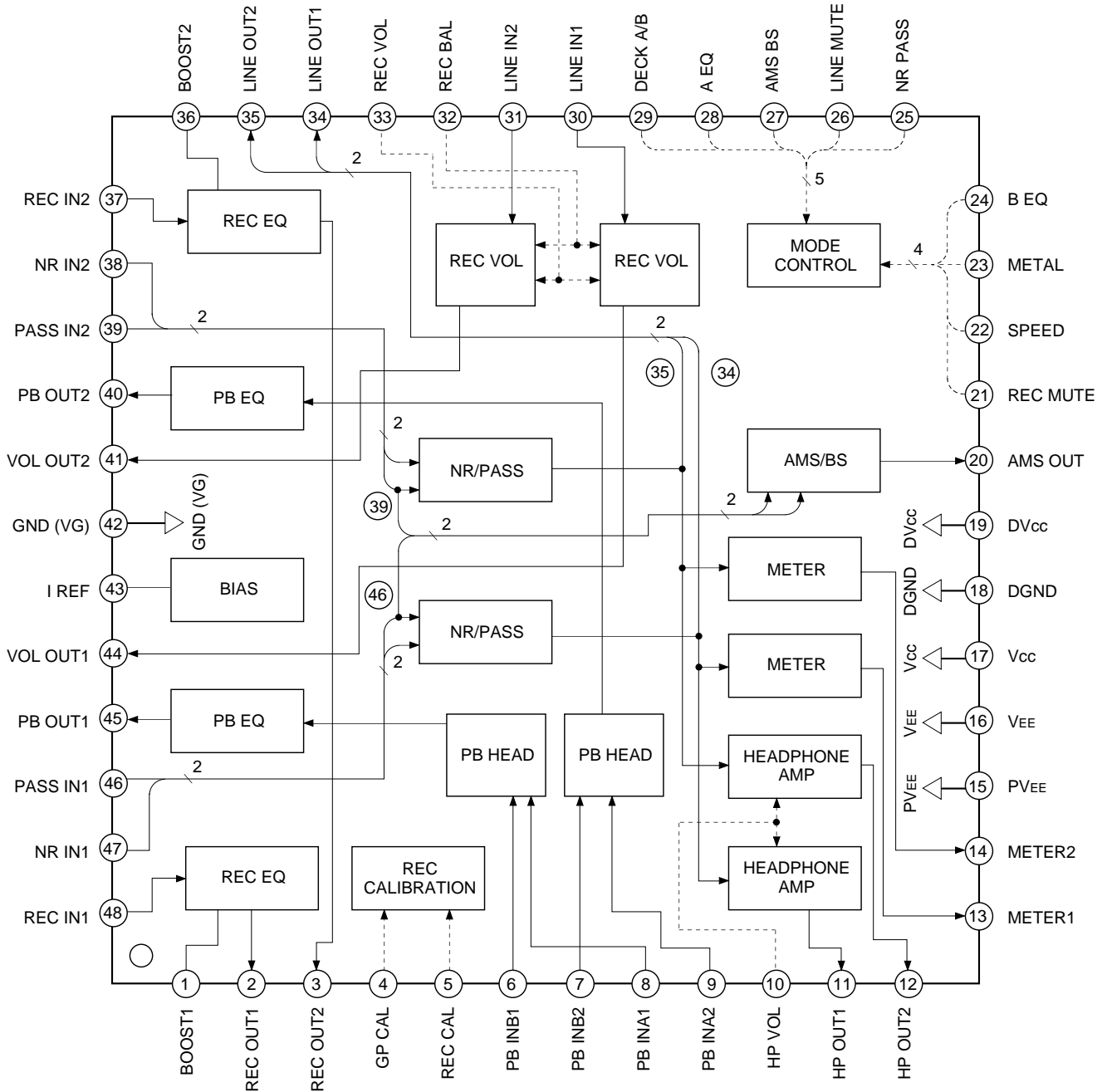

— Signal line
 - - - Control line

Pin Description

(Ta = 25°C, Vcc = 7V, VEE = -7V, DVcc = 5V, No signal)

Pin No.	Symbol	DC voltage	I/O	I/O resistance	Equivalent circuit	Description
1 36	BOOST1 BOOST2	0.0V	—	9.5kΩ		<p>Connects the external capacitor for low frequency boost of recording equalizer amplifier.</p> <p>*When low frequency boost is not executed: During positive/negative dual power supply → Connect to GND. During single power supply → Connect a capacitor (over 3.3μF).</p>
2 3	REC OUT1 REC OUT2	0.0V	O	0Ω		<p>Output of recording equalizer amplifier.</p>
4	GP CAL	2.5V (During OPEN)	I	54kΩ		<p>Calibration for high frequency gain of recording equalizer amplifier.</p> <p>Controls by applying the DC voltage of DGND to DVcc. High → Gain up Low → Gain down</p> <p>*When high frequency calibration function is not used, keep pin open.</p>

Pin No.	Symbol	DC voltage	I/O	I/O resistance	Equivalent circuit	Description
5	REC CAL	2.5V (During OPEN)	I	54kΩ		<p>Calibration for overall frequency gain of recording equalizer amplifier.</p> <p>Controls by applying the DC voltage of DGND to DVcc.</p> <p>High → Gain up Low → Gain down</p> <p>*When recording calibration function is not used, keep this pin open.</p>
6 7 8 9	PB INB1 PB INB2 PB INA1 PB INA2	0.0V	I	50kΩ		Input of playback equalizer amplifier.
37 48	REC IN2 REC IN1					Input of recording equalizer amplifier.
38 47	NR IN2 NR IN1					Input pin for connecting Dolby line (decode) output signal.
10 33	HP VOL REC VOL VOL	0.0V (During OPEN)	I	100kΩ		<p>Pin 10: Control for headphone volume Pin 33: Control for recording volume</p> <p>Controls by applying the DC voltage of DGND to DVcc for each pin.</p> <p>High → Volume up Low → Volume down</p>

Pin No.	Symbol	DC voltage	I/O	I/O resistance	Equivalent circuit	Description
11 12	HP OUT1 HP OUT2	0.0V	O	0Ω		Output of headphone volume
13 14	METER1 METER2	0.0V	O	—		Output of level meter amplifier
15 16	PV _{EE} V _{EE}	-7.0V	—	—	<p>⑮ —————> To PV_{EE}</p> <p>⑯ —————> To V_{EE}</p>	During positive/negative dual power supply → Connect to negative power supply. During single power supply → Connect to GND.
17	V _{CC}	7.0V	—	—	<p>⑰ —————> To V_{CC}</p>	Positive power supply.
18	DGND	0.0V	—	—	<p>⑱ —————> To DGND</p>	Connect to GND.
19	DV _{CC}	5.0V	—	60kΩ		Power supply for control.

Pin No.	Symbol	DC voltage	I/O	I/O resistance	Equivalent circuit	Description
20	AMS OUT	0.0V	O	0Ω		Output of AMS/BS amplifier.
21	REC MUTE	—	I	—		Mute ON/OFF switch of recording equalizer amplifier. Controls by applying the DC voltage of DGND to DVcc. High → Mute OFF Low → Mute ON *Soft mute/fader switch is possible by changing the time constant of the external time constant circuit.
22	SPEED	—	I	—		Tape speed switch High → High speed Low → Normal speed
23	METAL					Deck B metal tape switch High → Metal tape Low → Norm, CrO ₂ tape
26	LINE MUTE					Line mute ON/OFF switch High → Mute OFF Low → Mute ON
27	AMS BS					AMS/BS switch High → AMS mode Low → BS mode
29	DECK A/B					Deck A/B playback switch High → PBINB Low → PBINA

Pin No.	Symbol	DC voltage	I/O	I/O resistance	Equivalent circuit	Description
24	B EQ	—	I	—		Deck B equalizer switch High → 70μs EQ (CrO ₂ tape) Low → 120μs EQ (Norm tape)
25	NR PASS					NR/PASS input switch High → PASS IN Low → NR IN
28	A EQ					Deck A equalizer switch High → 70μs EQ Low → 120μs EQ
30 31	LINE IN1 LINE IN2	0.0V	I	0Ω		Line input. 47kΩ resistance connected externally.
32	REC BAL	2.5V (During OPEN)	I	100kΩ		Balance control of recording volume Controls by applying the DC voltage of DGND to DVcc. High → VOL OUT1 Low → VOL OUT2

Pin No.	Symbol	DC voltage	I/O	I/O resistance	Equivalent circuit	Description
34 35	LINE OUT1 LINE OUT2	0.0V	O	0Ω		Line output.
39 46	PASS IN2 PASS IN1	0.0V	I	20kΩ		Connects the playback equalizer amplifier output through DC cut off. Input for signals not passing Dolby decode.
40 45	PB OUT2 PB OUT1	0.0V	O	0Ω		Output of playback equalizer amplifier.

Pin No.	Symbol	DC voltage	I/O	I/O resistance	Equivalent circuit	Description
41 44	VOL OUT2 VOL OUT1	0.0V	O	0Ω		Output of recording volume.
42	GND (VG)	0.0V	—	15kΩ		<p>During positive/negative dual power supply → Connect to GND. During single power supply → Connect a capacitor (over 10μF) to remove center ripple.</p>
43	IREF	-5.8V	—	—		Reference current setting for recording/playback equalizer. Connect a 27kΩ resistance.

Electrical Characteristics

(Ta = 25°C, Vcc = 7V, VEE = -7V, DVcc = 5V)

Block	Item	Conditions	Min.	Typ.	Max.	Unit
Overall	Circuit current (Icc)	VOL/BAL = 2.5V, CAL = Open, LINE Mute = off, NR Pass = NR ON DECK A/B = A-DECK, A-EQ = 120μs, AMS/BS = BS Tape (B-EQ) = NORMAL, NORM-Speed, REC Mute = off	23.0	31.0	39.0	mA
Overall	Operating voltage range 1 (Positive/negative dual power supply)	VOL/BAL = 2.5V, CAL = Open, LINE Mute = off, NR Pass = NR ON DECK A/B = A-DECK, A-EQ = 120μs, AMS/BS = BS Tape (B-EQ) = NORMAL, NORM-Speed, REC Mute = off	±5.0	±7.0	±8.0	V
Overall	Operating voltage range 2 (Single power supply)	VOL/BAL = 2.5V, CAL = Open, LINE Mute = off, NR Pass = NR ON DECK A/B = A-DECK, A-EQ = 120μs, AMS/BS = BS Tape (B-EQ) = NORMAL, NORM-Speed, REC Mute = off	10.0	14.0	16.0	V
Recording equalizer	Recording equalizer amplifier Recording reference output level NORM-NORM mode	Reference output level of recording equalizer amplifier (315Hz) (Output level for magnetic flux of "0dB = 250nWb/m"; tape reference level) Recording equalizer block uses this level as reference.	—	-3.0	—	dBv
Recording equalizer	Recording equalizer amplifier Recording reference input level NORM-NORM mode	Input level for outputting reference output level of 315Hz, -3.0dBv	-19.2	-17.7	-16.2	dBv
Recording equalizer	NORM-NORM mode REC-EQ frequency characteristics 1 (3kHz, -20 dB)	NORM-Tape, NORM-Speed mode By inputting 3kHz signal attenuated from reference by -20dB to REC IN pin, relative deviation is measured for NORM-NS at 315Hz.	-1.6	0.2	2.2	dB
Recording equalizer	NORM-NORM mode REC-EQ frequency characteristics 2 (8 kHz, -20 dB)	NORM-Tape, NORM-Speed mode By inputting 8 kHz signal attenuated from reference by -20dB to REC IN pin, relative deviation is measured for NORM-NS at 315Hz.	2.9	5.6	8.1	dB
Recording equalizer	NORM-NORM mode REC-EQ frequency characteristics 3 (12 kHz, -20 dB)	NORM-Tape, NORM-Speed mode By inputting 12kHz signal attenuated from reference by -20dB to REC IN pin, relative deviation is measured for NORM-NS at 315Hz.	7.5	11.5	15.1	dB

Block	Item	Conditions	Min.	Typ.	Max.	Unit
Recording equalizer	CrO ₂ -NORM mode REC-EQ frequency characteristics 1 (3kHz, -20dB)	CrO ₂ -Tape, NORM-Speed mode By inputting 3kHz signal attenuated from reference by -20dB to REC IN pin, relative deviation is measured for NORM-NS at 315Hz.	4.3	6.2	7.9	dB
Recording equalizer	CrO ₂ -NORM mode REC-EQ frequency characteristics 2 (8kHz, -20dB)	CrO ₂ -Tape, NORM-Speed mode By inputting 8kHz signal attenuated from reference by -20dB to REC IN pin, relative deviation is measured for NORM-NS at 315Hz.	9.0	11.4	13.7	dB
Recording equalizer	CrO ₂ -NORM mode REC-EQ frequency characteristics 3 (12kHz, -20dB)	CrO ₂ -Tape, NORM-Speed mode By inputting 12kHz signal attenuated from reference by -20dB to REC IN pin, relative deviation is measured for NORM-NS at 315Hz.	13.4	17.1	20.5	dB
Recording equalizer	METAL-NORM mode REC-EQ frequency characteristics 1 (3kHz, -20dB)	METAL-Tape, NORM-Speed mode By inputting 3kHz signal attenuated from reference by -20dB to REC IN pin, relative deviation is measured for NORM-NS at 315Hz.	4.1	5.8	7.5	dB
Recording equalizer	METAL-NORM mode REC-EQ frequency characteristics 2 (8kHz, -20dB)	METAL-Tape, NORM-Speed mode By inputting 8kHz signal attenuated from reference by -20dB to REC IN pin, relative deviation is measured for NORM-NS at 315Hz.	7.4	9.4	11.4	dB
Recording equalizer	METAL-NORM mode REC-EQ frequency characteristics 3 (12kHz, -20dB)	METAL-Tape, NORM-Speed mode By inputting 12kHz signal attenuated from reference by -20dB to REC IN pin, relative deviation is measured for NORM-NS at 315Hz.	10.5	13.5	16.3	dB
Recording equalizer	NORM-HIGH mode REC-EQ frequency characteristics 1 (5kHz, -20dB)	NORM-Tape, HIGH-Speed mode By inputting 5kHz signal attenuated from reference by -20dB to REC IN pin, relative deviation is measured for NORM-NS at 315Hz.	-5.1	-3.3	-1.6	dB
Recording equalizer	NORM-HIGH mode REC-EQ frequency characteristics 2 (15kHz, -20dB)	NORM-Tape, HIGH-Speed mode By inputting 15kHz signal attenuated from reference by -20dB to REC IN pin, relative deviation is measured for NORM-NS at 315Hz.	-0.5	2.3	5.0	dB
Recording equalizer	NORM-HIGH mode REC-EQ frequency characteristics 3 (20kHz, -20dB)	NORM-Tape, HIGH-Speed mode By inputting 20kHz signal attenuated from reference by -20dB to REC IN pin, relative deviation is measured for NORM-NS at 315Hz.	3.1	6.8	10.2	dB
Recording equalizer	CrO ₂ -HIGH mode REC-EQ frequency characteristics 1 (5kHz, -20dB)	CrO ₂ -Tape, HIGH-Speed mode By inputting 5kHz signal attenuated from reference by -20dB to REC IN pin, relative deviation is measured for NORM-NS at 315Hz.	1.0	2.8	4.5	dB
Recording equalizer	CrO ₂ -HIGH mode REC-EQ frequency characteristics 2 (15kHz, -20dB)	CrO ₂ -Tape, HIGH-Speed mode By inputting 15kHz signal attenuated from reference by -20dB to REC IN pin, relative deviation is measured for NORM-NS at 315Hz.	5.4	8.0	10.5	dB
Recording equalizer	CrO ₂ -HIGH mode REC-EQ frequency characteristics 3 (20kHz, -20dB)	CrO ₂ -Tape, HIGH-Speed mode By inputting 20kHz signal attenuated from reference by -20dB to REC IN pin, relative deviation is measured for NORM-NS at 315Hz.	8.3	11.9	15.2	dB

Block	Item	Conditions	Min.	Typ.	Max.	Unit
Recording equalizer	METAL-HIGH mode REC-EQ frequency characteristics 1 (5kHz, -20dB)	METAL-Tape, HIGH-Speed mode By inputting 5kHz signal attenuated from reference by -20dB to REC IN pin, relative deviation is measured for NORM-NS at 315Hz.	1.5	3.2	4.7	dB
Recording equalizer	METAL-HIGH mode REC-EQ frequency characteristics 2 (15kHz, -20dB)	METAL-Tape, HIGH-Speed mode By inputting 15kHz signal attenuated from reference by -20dB to REC IN pin, relative deviation is measured for NORM-NS at 315Hz.	3.4	5.9	8.2	dB
Recording equalizer	METAL-HIGH mode REC-EQ frequency characteristics 3 (20kHz, -20dB)	METAL-Tape, HIGH-Speed mode By inputting 20kHz signal attenuated from reference by -20dB to REC IN pin, relative deviation is measured for NORM-NS at 315Hz.	5.9	8.8	11.5	dB
Recording equalizer	NORM-NORM mode REC-EQ signal handling (1kHz, THD=1%, RL=2.7kΩ)	NORM-Tape, NORM-Speed mode, RL = 2.7kΩ Output level when THD becomes 1% by inputting 1kHz signal	12.0	14.0	—	dB
Recording equalizer	NORM-NORM mode REC-EQ total harmonic distortion (1kHz, 0.0dB, RL=2.7kΩ)	NORM-Tape, NORM-Speed mode, RL = 2.7kΩ By inputting 1kHz, 0.0dB (reference input level) signal, distortion is measured. (Distortion is measured as THD + N.)	—	0.12	0.6	%
Recording equalizer	NORM-NORM mode REC-EQ S/N ratio ("A" weighting filter)	NORM-Tape, NORM-Speed mode, Rg = 5.1kΩ Noise is measured using "A" weighting filter with no signal. (Measured value is shown in relative value to reference level.)	57.0	61.0	—	dB
Recording equalizer	NORM-NORM mode Output DC offset voltage (REC OUT pin)	NORM-Tape, NORM-Speed mode, no signal DC offset voltage is measured at REC OUT pin.	-280	0	280	mV
Recording equalizer	NORM-NORM mode REC-EQ mute characteristics 1 (REC-MUTE = 0.5V)	NORM-Tape, NORM-Speed mode, REC-MUTE = 0.5V By inputting 1kHz signal which is +12dB up from reference input level, attenuation is measured during recording mute. (Using 1kHz BPF)	—	-90.0	-82.0	dB
Recording equalizer	NORM-NORM mode REC-EQ mute characteristics 2 (REC-MUTE = 2.5V)	NORM-Tape, NORM-Speed mode, REC-MUTE = 2.5V By inputting 1kHz, 0.0dB (reference level) signal, attenuation characteristics curve of soft mute function is measured (with 2.5V at REC-MUTE pin).	-8.0	-6.6	-5.0	dB
Recording equalizer	NORM-NORM mode REC-EQ REC-CAL characteristics 1 (REC-CAL = 5.0V)	NORM-Tape, NORM-Speed mode, REC-CAL = 5.0V By inputting 315Hz signal attenuated from reference by -20dB, REC-CAL function is measured as variation from standard mode.	2.2	4.6	7.0	dB
Recording equalizer	NORM-NORM mode REC-EQ REC-CAL characteristics 2 (REC-CAL = 0.0V)	NORM-Tape, NORM-Speed mode, REC-CAL = 0.0V By inputting 315Hz signal attenuated from reference by -20dB, REC-CAL function is measured as variation from standard mode.	-6.8	-5.4	-4.0	dB

Black	Item	Conditions	Min.	Typ.	Max.	Unit.
Recording equalizer	NORM-NORM mode REC-EQ Gp-CAL characteristics 1 (Gp-CAL = 5.0V)	NORM-Tape, NORM-Speed mode, Gp-CAL = 5.0V By inputting 8kHz signal attenuated from reference by -20dB, Gp-CAL function is measured as variation from standard mode.	1.4	3.2	5.5	dB
Recording equalizer	NORM-NORM mode REC-EQ Gp-CAL characteristics 2 (Gp-CAL = 0.0V)	NORM-Tape, NORM-Speed mode, Gp-CAL = 0.0V By inputting 8kHz signal attenuated from reference by -20dB, Gp-CAL function is measured as variation from standard mode.	-5.8	-3.7	-1.5	dB
Recording volume	Recording volume amplifier Recording volume characteristics 1 (REC-VOL = 5.0V, REC-BAL = 2.5V)	REC-VOL = 5.0V, REC-BAL = 2.5V, Rin = 47k Ω By inputting 1kHz, -6.0dBv signal to Rin = 47k Ω connected to "LINE IN" pin, full gain of recording volume amplifier is measured.	2.4	5.0	7.7	dB
Recording volume	Recording volume amplifier Recording volume characteristics 2 (REC-VOL = 2.0V, REC-BAL = 2.5V)	REC-VOL = 2.0V, REC-BAL = 2.5V, Rin = 47k Ω By inputting 1kHz, -6.0dBv signal to Rin = 47k Ω connected to "LINE IN" pin, attenuation of recording volume amplifier is measured.	-9.7	-8.7	-7.7	dB
Recording volume	Recording volume amplifier Recording volume attenuation (REC-VOL = 0.0V, REC-BAL = 2.5V)	REC-VOL = 0.0V, REC-BAL = 2.5V, Rin = 47k Ω By inputting 1kHz, -6.0dBv signal, max. volume attenuation of recording volume amplifier is measured. (Using 1kHz BPF)	—	-82.0	-77.0	dB
Recording volume	Recording volume amplifier REC-VOL signal handling (1 kHz, THD = 1%, RL = 2.7k Ω)	REC-VOL = 2.0V, REC-BAL = 2.5V, Rin = 47k Ω , RL = 2.7k Ω Input level when THD becomes 1% by inputting 1kHz signal	6.0	8.0	—	dBv
Recording volume	Recording volume amplifier REC-VOL total harmonic distortion (1kHz, -6.0dBv, RL = 2.7k Ω)	REC-VOL = 2.0V, REC-BAL = 2.5V, Rin = 47k Ω , RL = 2.7k Ω By inputting 1kHz, -6.0dBv (reference input level) signal, distortion is measured. (Distortion is measured as THD + N.)	—	0.06	0.4	%
Recording volume	Recording volume amplifier REC-VOL S/N ratio ("A" weighting filter)	REC-VOL = 5.0V, REC-BAL = 2.5V, Rin = 47k Ω Noise is measured using "A" weighting filter with no signal. (Measured value is shown in relative value to full gain.)	77.0	82.0	—	dB
Recording volume	Recording volume amplifier Output DC offset voltage (VOL OUT pin)	REC-VOL = 5.0V, REC-BAL = 2.5V, Rin = 47k Ω DC offset voltage is measured at VOL OUT pin with no signal.	120	0	120	mV

Block	Item	Conditions	Min.	Typ.	Max.	Unit
Recording volume	Recording volume amplifier REC-VOL balance characteristics 1 (REC-VOL = 5.0V, REC-BAL = 0.0V)	REC-VOL = 5.0V, REC-BAL = 0.0V, Rin = 47k Ω , (1kHz-BPF) Attenuation of "VOL OUT1" at 1kHz is measured. To "VOL OUT2"	—	-55.0	-44.0	dB
Recording volume	Recording volume amplifier REC-VOL balance characteristics 2 (REC-VOL = 5.0V, REC-BAL = 5.0V)	REC-VOL = 5.0V, REC-BAL = 5.0V, Rin = 47k Ω , (1kHz-BPF) Attenuation of "VOL OUT2" at 1kHz is measured. To "VOL OUT1"	—	-55.0	-44.0	dB
Line amplifier	Line amplifier Line amplifier gain (NR IN = 1kHz, -11.0dBv)	NR Pass = NR ON (1.0V), line mute = mute off (2.5V) Gain at 1kHz is measured.	3.8	4.8	5.8	dB
Line amplifier	Line amplifier signal handling (1kHz, THD = 1%, RL = 2.7k Ω)	NR Pass = NR ON (1.0V), line mute = off (2.5V), RL = 2.7k Ω Input level when THD becomes 1% by inputting 1kHz signal	12.0	15.0	—	dB
Line amplifier	Line amplifier Line amplifier total harmonic distortion (1kHz, -11.0dBv, RL = 2.7k Ω)	NR Pass = NR ON (1.0V), line mute = off (2.5V), RL = 2.7k Ω By inputting 1kHz, -11.0dB (reference input level) signal, distortion is measured. (Distortion is measured as THD + N.)	—	0.03	0.4	%
Line amplifier	Line amplifier Line amplifier S/N ratio ("A" weighting filter)	NR Pass = NR ON (1.0V), line mute = off (2.5V), Rg = 5.1k Ω Noise is measured using "A" weighting filter with no signal. (Measured value is shown in relative value to reference level.)	75.8	85.8	—	dB
Line amplifier	Line amplifier Output DC offset voltage (LINE OUT pin)	NR Pass = NR ON (1.0V), line mute = off (2.5V) DC offset voltage is measured with no signal at LINE OUT pin.	0	30	60	mV
Line amplifier	Line amplifier Line amplifier line mute characteristics (Line mute = 1.0V)	NR Pass = NR ON (1.0V), line mute = mute on (1.0V) By inputting 1kHz, +1.0dBv signal to NR IN pin, attenuation is measured during line mute. (Using 1kHz BPF)	—	-83.0	-74.0	dB
HP volume	HP volume amplifier HP volume characteristics 1 (HP-VOL = 5.0V, 1kHz, -11dBv)	HP-VOL = 5.0V, NR Pass = 1.0V, line mute = 2.5V Full gain of HP volume amplifier at 1kHz is measured.	17.5	19.0	20.5	dB
HP volume	HP volume amplifier HP volume characteristics 2 (HP-VOL = 2.0V, 1kHz, -11dBv)	HP-VOL = 2.0V, NR Pass = 1.0V, line mute = 2.5V Attenuation of HP volume amplifier at 1kHz is measured.	-9.5	-8.0	-6.5	dB

Block	Item	Conditions	Min.	Typ.	Max.	Unit
HP volume	HP volume amplifier HP volume attenuation (HP-VOL = 0.0V, 1kHz, +1.0dBv)	HP-VOL = 0.0V, NR Pass = 1.0V, line mute = 2.5V Max. volume attenuation at 1kHz is measured. (Using 1kHz BPF)	—	-81.0	-77.0	dB
HP volume	HP volume amplifier HP-VOL signal handling (1kHz, THD = 3%, RL = 150Ω)	HP-VOL = 2.0V, NR Pass = 1.0V, line mute = 2.5V, RL = 150Ω Output level when THD becomes 3% by inputting 1kHz signal	10.0	11.0	—	dBv
HP volume	HP volume amplifier HP-VOL total harmonic distortion (1kHz, -6.0dBv, RL = 2.7kΩ)	HP-VOL = 2.0V, NR Pass = 1.0V, line mute = 2.5V, RL = 150Ω By inputting 1kHz, -11.0dBv (reference input level) signal, distortion is measured. (Distortion is measured as THD + N.)	—	0.40	1.2	%
HP volume	HP volume amplifier HP-VOL S/N ratio ("A" weighting filter)	HP-VOL = 5.0V, NR Pass = 1.0V, line mute = 2.5V Noise is measured using "A" weighting filter with no signal. (Measured value is shown in relative value to full gain.)	93.0	97.0	—	dB
HP volume	HP volume amplifier Output DC offset voltage (HP OUT pin)	HP-VOL = 5.0V, NR Pass = 1.0V, line mute = 2.5V DC offset voltage is measured with no signal at HP OUT pin.	0	125	250	mV
Level meter	Level meter amplifier Level meter characteristics 1 (NR IN = 1kHz, -11.0dBv)	NR Pass = NR ON (1.0V), line mute = mute off (2.5V) By inputting 1kHz, -11.0dBv signal, output DC voltage is measured at METER pin.	1.43	1.53	1.63	V
Level meter	Level meter amplifier Level meter characteristics 2 (NR IN = 1kHz, -21.0dBv)	NR Pass = NR ON (1.0V), line mute = mute off (2.5V) By inputting 1kHz, -21.0dBv (-10.0dB down) signal, output DC voltage is measured at METER pin.	0.46	0.53	0.60	V
Playback equalizer	120μs-NS, A-DECK mode Playback reference input level (Playback equalizer amplifier gain)	A-DECK, A-EQ = 120μs, NORM-Speed mode By inputting 315Hz, -31.0dBv (reference input level) signal to PB IN pins (Pins 8/9), output level is measured.	-11.8	-11.2	-10.6	dBv
Playback equalizer	Playback equalizer amplifier PB-EQ frequency characteristics 1 120μs-NS, A-DECK mode	A-DECK, A-EQ = 120μs, NORM-Speed mode By inputting 5kHz, -31.0dBv (reference input level) signal, relative deviation is measured at 120μs, 315Hz.	-0.9	0.6	1.7	dB
Playback equalizer	Playback equalizer amplifier PB-EQ frequency characteristics 2 70μs-NS, A-DECK mode	A-DECK, A-EQ = 70μs, NORM-Speed mode By inputting 5kHz, -31.0dBv (reference input level) signal, relative deviation is measured at 120μs, 315Hz.	-4.7	-3.6	-2.3	dB

Block	Item	Conditions	Min.	Typ.	Max.	Unit
Playback equalizer	Playback equalizer amplifier PB-EQ frequency characteristics 3 120 μ s-HS, A-DECK mode	A-DECK, A-EQ = 120 μ s, HIGH-Speed mode By inputting 5kHz, -31.0dBv (reference input level) signal, relative deviation is measured at 120 μ s, 315Hz.	-0.6	0.4	1.6	dB
Playback equalizer	Playback equalizer amplifier PB-EQ frequency characteristics 4 70 μ s-HS, A-DECK mode	A-DECK, A-EQ = 70 μ s, HIGH-Speed mode By inputting 5kHz, -31.0dBv (reference input level) signal, relative deviation is measured at 120 μ s, 315Hz.	-4.7	-3.6	-2.3	dB
Playback equalizer	120 μ s-NS, A-DECK mode PB-EQ signal handling (1kHz, THD = 1%, RL = 2.7k Ω)	A-DECK, A-EQ = 120 μ s, NORM-Speed mode, RL = 2.7k Ω Output level when THD becomes 1% by inputting 1kHz signal	12.0	17.0	—	dB
Playback equalizer	120 μ s-NS, A-DECK mode PB-EQ total harmonic distortion (1kHz, 0.0dB, RL = 2.7k Ω)	A-DECK, A-EQ = 120 μ s, NORM-Speed mode, RL = 2.7k Ω By inputting 1kHz, -31.0dBv (reference input level) signal, distortion is measured. (Distortion is measured as THD + N.)	—	0.08	0.6	%
Playback equalizer	120 μ s-NS, A-DECK mode PB-EQ S/N ratio ("A" weighting filter)	A-DECK, A-EQ = 120 μ s, NORM-Speed mode, Rg = 5.1k Ω Noise is measured using "A" weighting filter with no signal. (Measured value is shown in relative value to reference level.)	58.8	63.8	—	dB
Playback equalizer	120 μ s-NS, A-DECK mode Output DC offset voltage (PB OUT pin)	A-DECK, A-EQ = 120 μ s, NORM-Speed mode DC offset voltage is measured with no signal at PB OUT pin.	10	180	350	mV
Playback equalizer	Playback equalizer amplifier DECK-A/B switch characteristics 120 μ s-NS, B-DECK mode	B-DECK, B-EQ = NORM Tape, NORM-Speed mode By inputting 1kHz, -31.0dBv (reference input level) signal to Pins 6 /7, relative deviation is measured for A-DECK at 120 μ s-NS, 315Hz.	-1.5	0.0	1.5	dB
NR Pass amplifier	NR Pass amplifier NR Pass amplifier gain (PB IN = 1kHz, -31.0dBv)	NR Pass = 2.5V, A-DECK, 120 μ s-NS, line mute off By inputting 1kHz, -31.0dBv (reference input level) signal to PB IN pins (Pins 8/9), relative value is measured to PB OUT.	3.2	4.7	6.2	dB
NR Pass amplifier	NR Pass amplifier Output DC offset voltage (LINE OUT pin)	NR Pass = 2.5V, A-DECK, 120 μ s-NS, line mute off DC offset voltage is measured with no signal at LINE OUT pin.	0	30	60	V

Block	Item	Conditions	Min.	Typ.	Max.	Unit
AMS/BS amplifier	AMS/BS amplifier AMS/BS frequency characteristics 1 AMS, 120 μ s-NS, A-DECK mode	AMS, A-DECK, A-EQ = 120 μ s, NORM-Speed mode By inputting 3kHz, -51.0dBv signal to PB IN pins (Pins 8/9), difference between output level and level at PB OUT pin is measured.	35.3	36.8	38.3	dB
AMS/BS amplifier	AMS/BS amplifier AMS/BS frequency characteristics 2 AMS, 120 μ s-NS, A-DECK mode	AMS, A-DECK, A-EQ = 120 μ s, NORM-Speed mode By inputting 600Hz, -51.0dBv signal to PB IN pins (Pins 8/9), deviation from output level of frequency characteristics 1 is measured.	-4.5	-3.0	-1.5	dB
AMS/BS amplifier	AMS/BS amplifier AMS/BS frequency characteristics 3 BS, 120 μ s-NS, A-DECK mode	BS, A-DECK, A-EQ = 120 μ s, NORM-Speed mode By inputting 1kHz, -51.0dBv signal to PB IN pins (Pins 8/9), difference between output level and level at PB OUT pin is measured.	45.9	47.4	48.9	dB
AMS/BS amplifier	AMS/BS amplifier AMS/BS frequency characteristics 4 BS, 120 μ s-NS, A-DECK mode	BS, A-DECK, A-EQ = 120 μ s, NORM-Speed mode By inputting 100Hz, -51.0dBv signal to PB IN pins (Pins 8/9), deviation from output level of frequency characteristics 3 is measured.	-5.8	-4.1	-2.4	dB
AMS/BS amplifier	AMS, 120 μ s-NS, A-DECK mode Output DC offset voltage (AMS OUT pin)	AMS, A-DECK, A-EQ = 120 μ s, NORM-Speed mode DC offset voltage is measured with no signal at AMS OUT pin.	-1.95	0.05	2.05	V
AMS/BS amplifier	BS, 120 μ s-NS, A-DECK mode Output DC offset voltage (AMS OUT pin)	BS, A-DECK, A-EQ = 120 μ s, NORM-Speed mode DC offset voltage is measured with no signal at AMS OUT pin.	-2.0	0.0	2.0	V

Electrical Characteristics Measurement Circuit

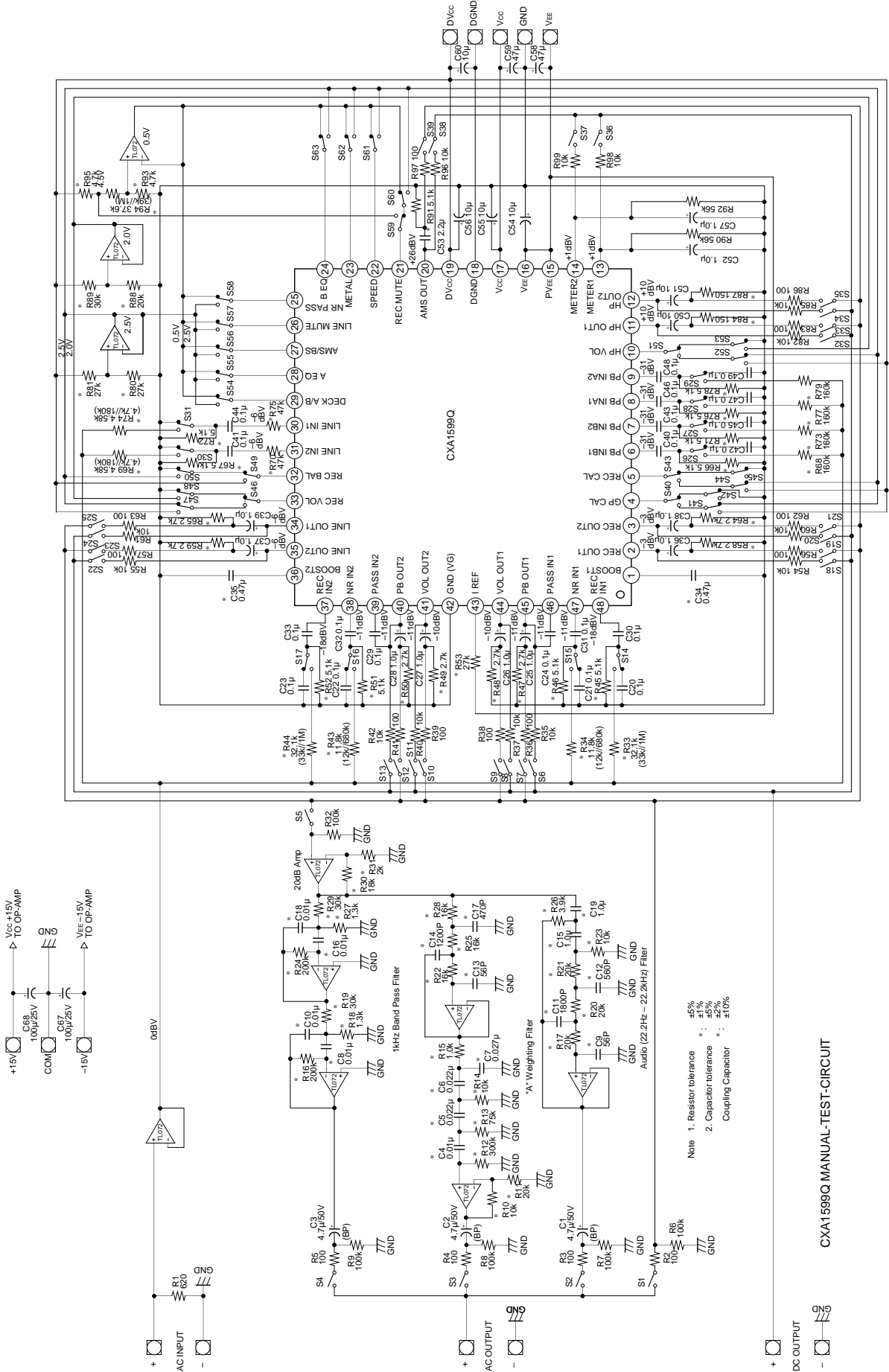

CXA1599Q MANUAL-TEST-CIRCUIT

Application Circuit

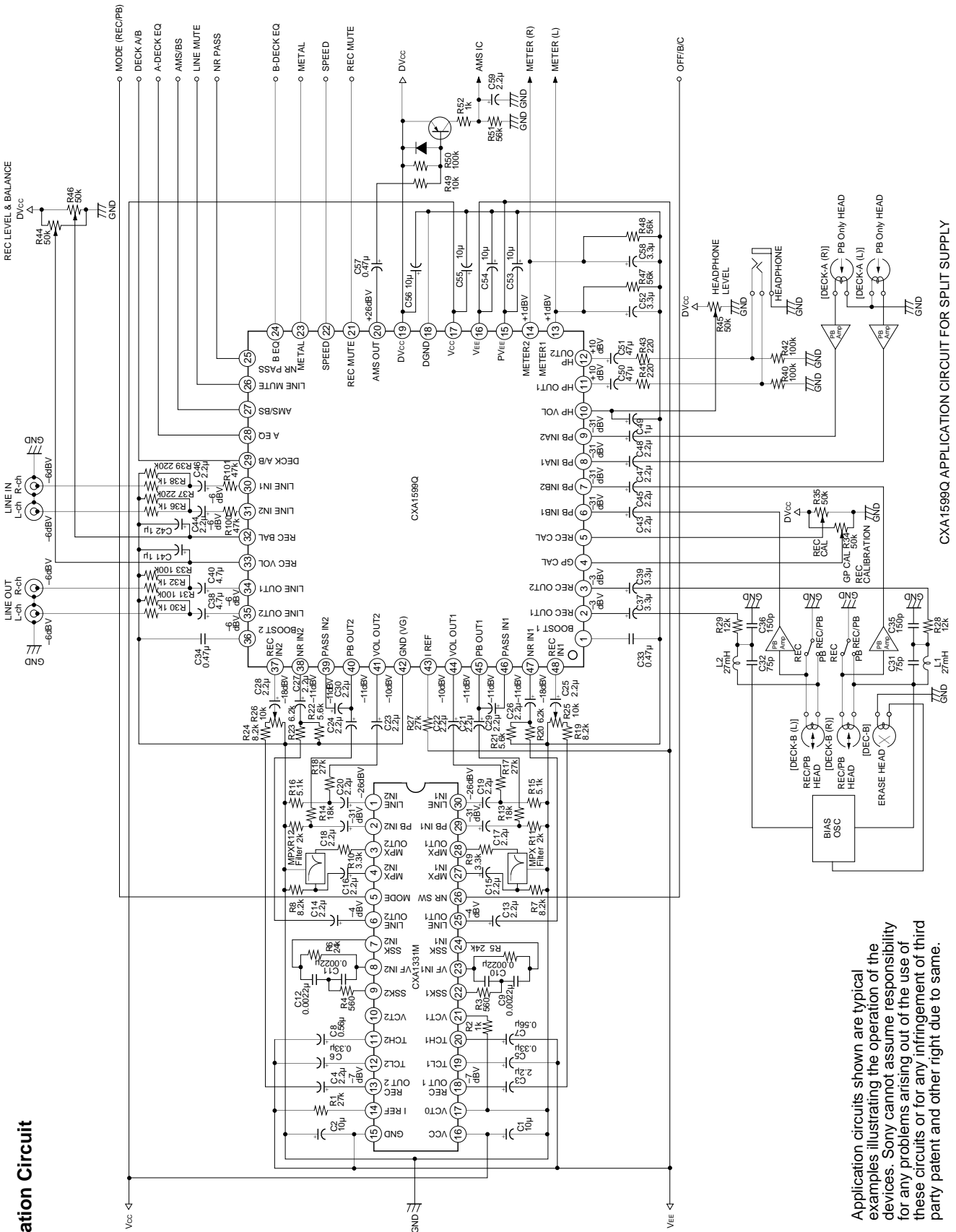

CXA1599Q APPLICATION CIRCUIT FOR SPLIT SUPPLY

Application circuits shown are typical examples illustrating the operation of the devices. Sony cannot assume responsibility for any problems arising out of the use of these circuits or for any infringement of third party patent and other right due to same.

Example of Representative Characteristics

Recording equalizer frequency characteristics (Normal speed)

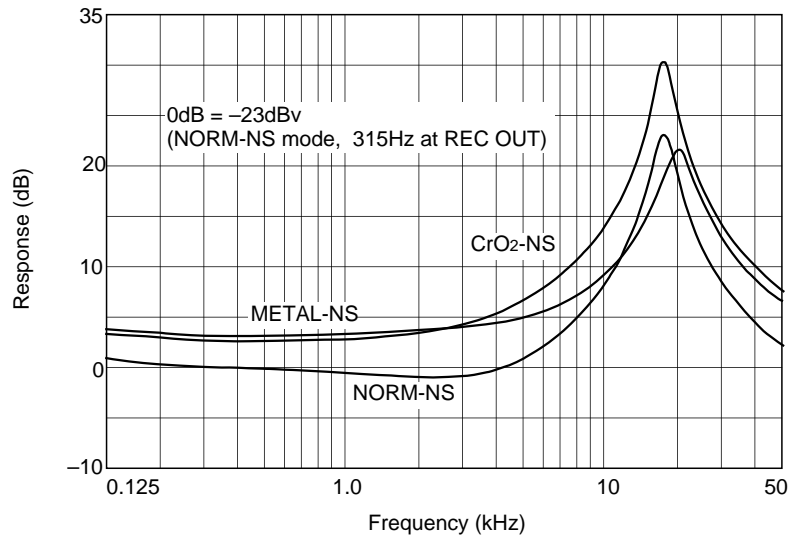

Recording equalizer frequency characteristics (Double speed)

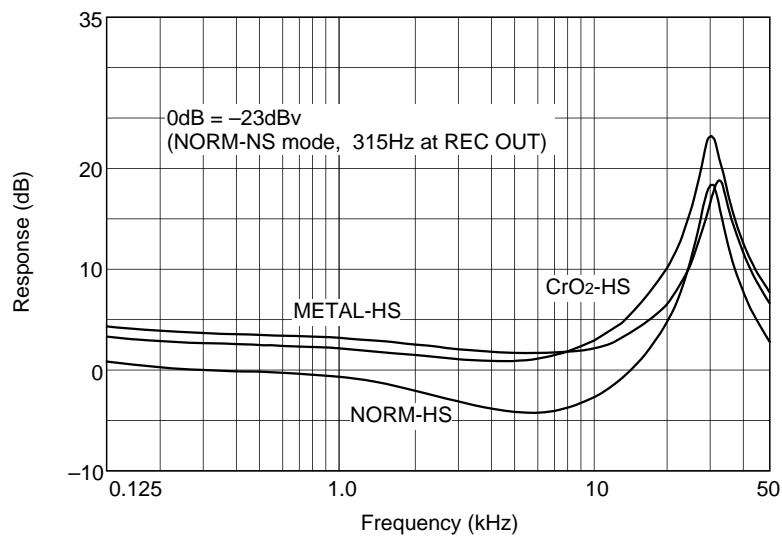

Playback equalizer frequency characteristics

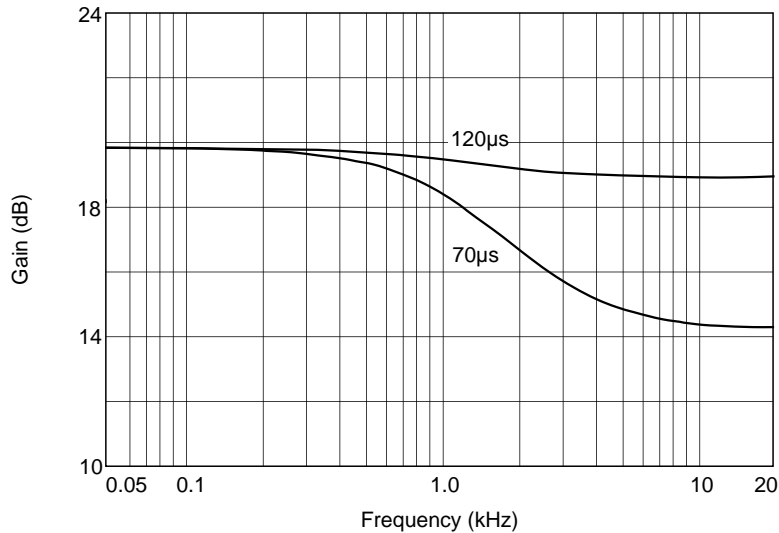

Recording equalizer calibration characteristics (REC CAL & Gp CAL)

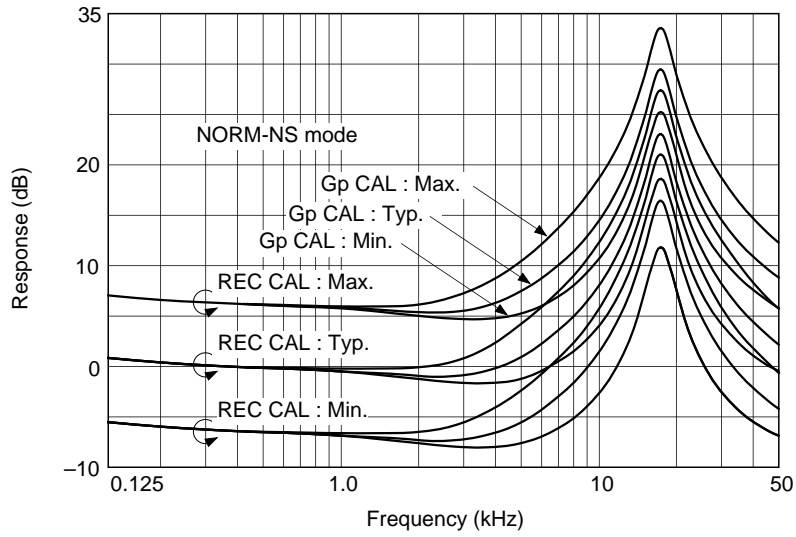

Recording equalizer calibration characteristics (Gp CAL)

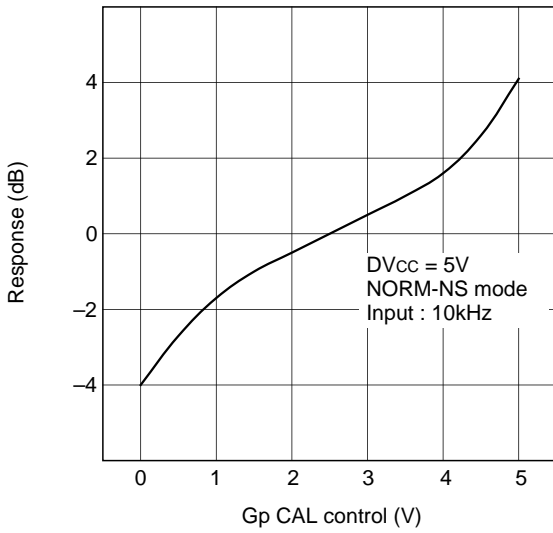

REC MUTE characteristics

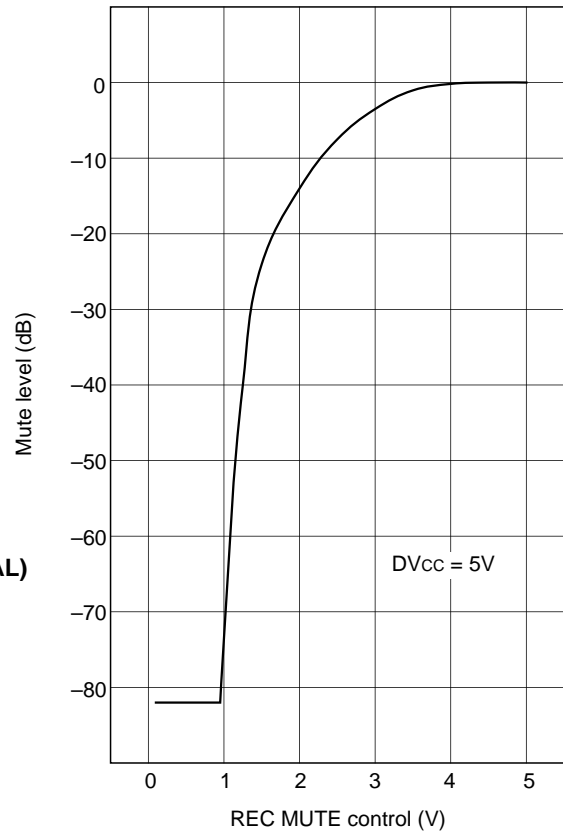

Recording equalizer calibration characteristics (REC CAL)

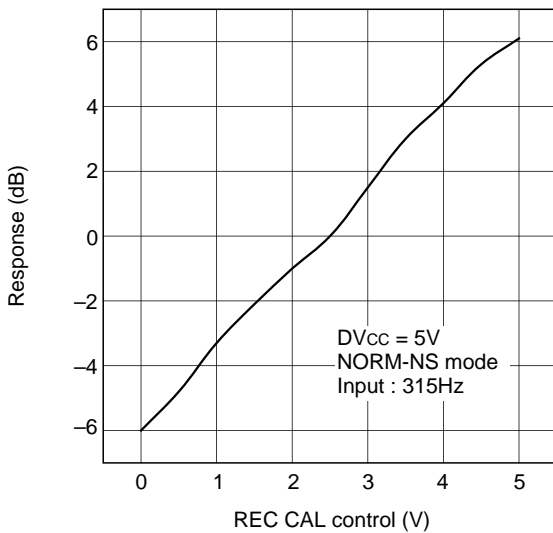

Recording volume characteristics

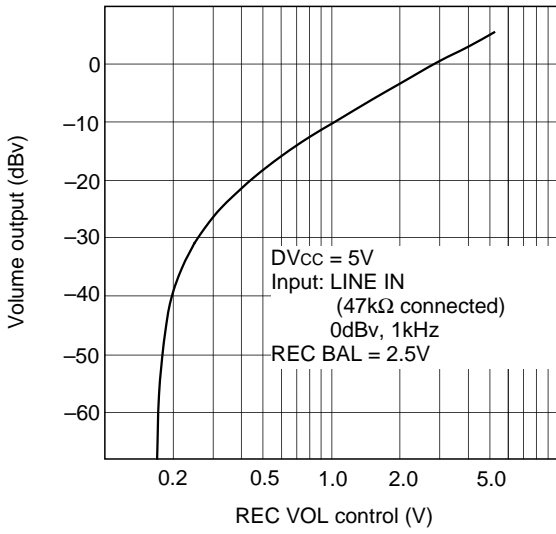

Recording balance characteristics

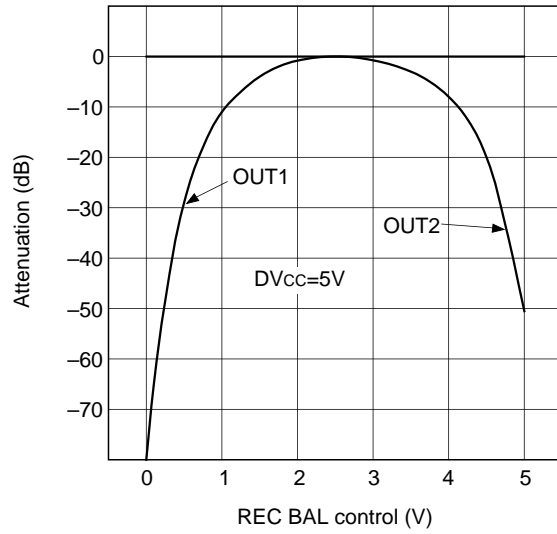

Headphone volume characteristics

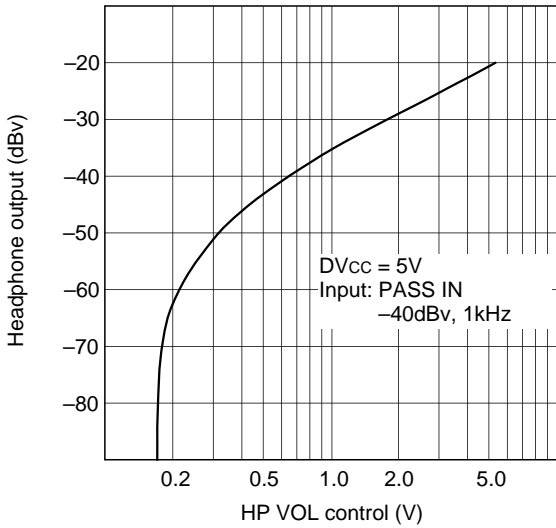

Level meter output characteristics

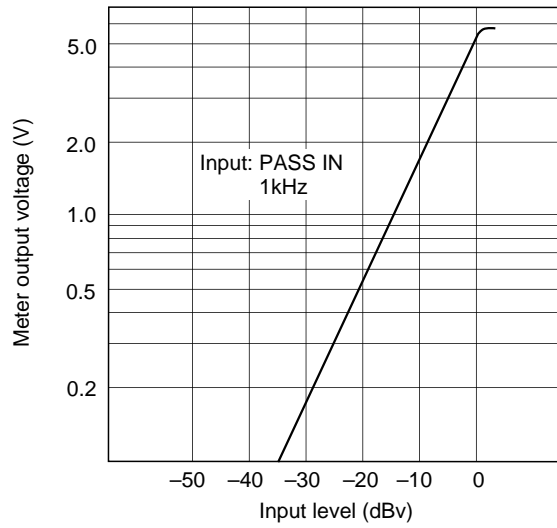

A.M.S./B.S. frequency characteristics

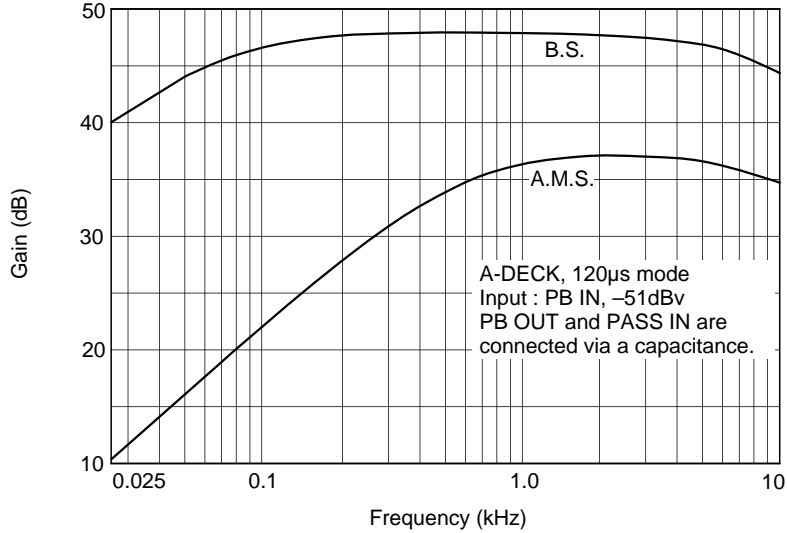

Package Outline Unit: mm

48PIN QFP (PLASTIC)

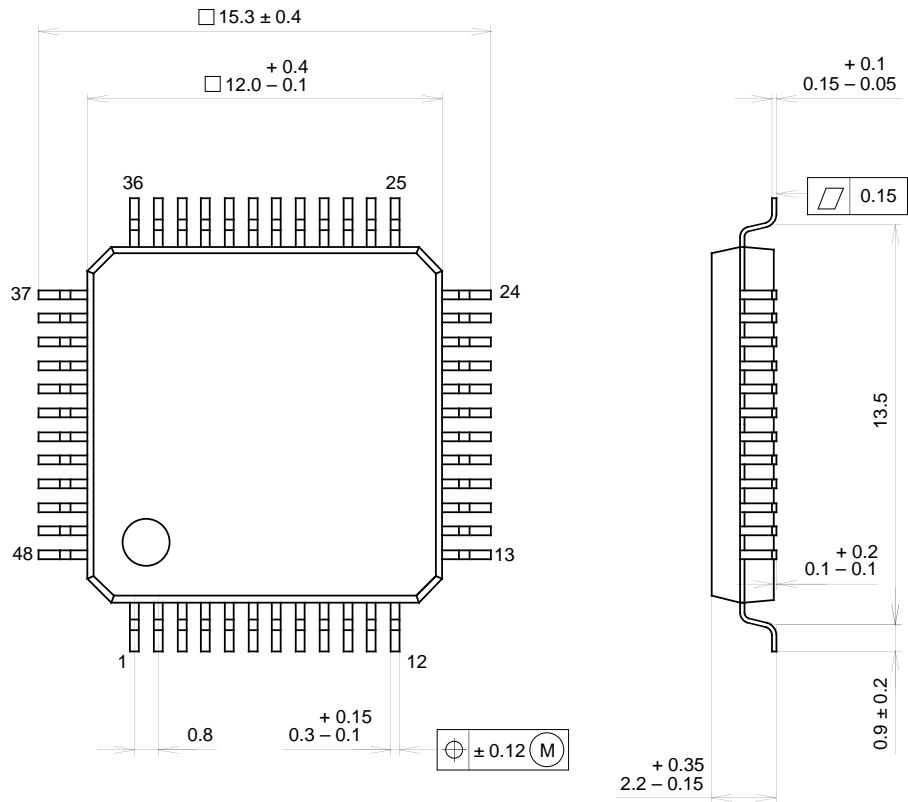

PACKAGE STRUCTURE

SONY CODE	QFP-48P-L04
EIAJ CODE	*QFP048-P-1212-B
JEDEC CODE	_____

PACKAGE MATERIAL	EPOXY RESIN
LEAD TREATMENT	SOLDER / PALLADIUM PLATING
LEAD MATERIAL	COPPER / 42 ALLOY
PACKAGE WEIGHT	0.7g