

SONY

CXA1709P

Pre-driver for Ultra-High Resolution Computer Display

Description

The CXA1709P is a bipolar IC designed for use in ultra-high resolution computer displays.

Features

- Built-in super wide-band amplifier (250 MHz/-3dB typ.)
- 1 channel to 1 package
- Contrast can be controlled by DC.
- Rise/fall time of 2ns or less due to output amplitude of 4 VP-P
- Drive adjustment for the three channels (R, G, B) is easily accomplished because the contrast characteristic is linear.

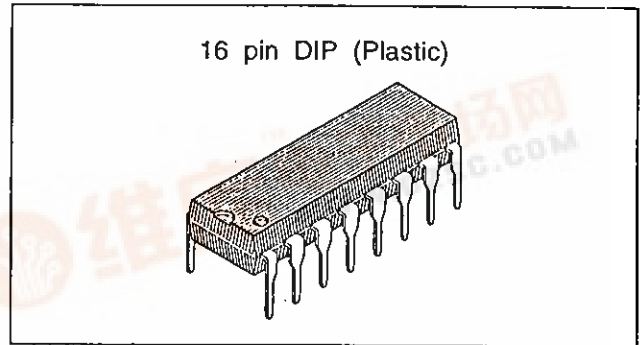

Operating Conditions

- Recommended supply voltage 12.0 V
- Operating range 12 ±0.5 V

Absolute Maximum Ratings (Ta=25°C)

• Supply voltage	Vcc	14	V
• Operating temperature	Topr	-20 to +75	°C
• Storage temperature	Tstg	-65 to +150	°C
• Allowable power dissipation	Pd	1040	mW

Structure

Bipolar silicon monolithic IC

Applications

Pre-driver for ultra-high resolution computer displays

Block Diagram and Pin Configuration

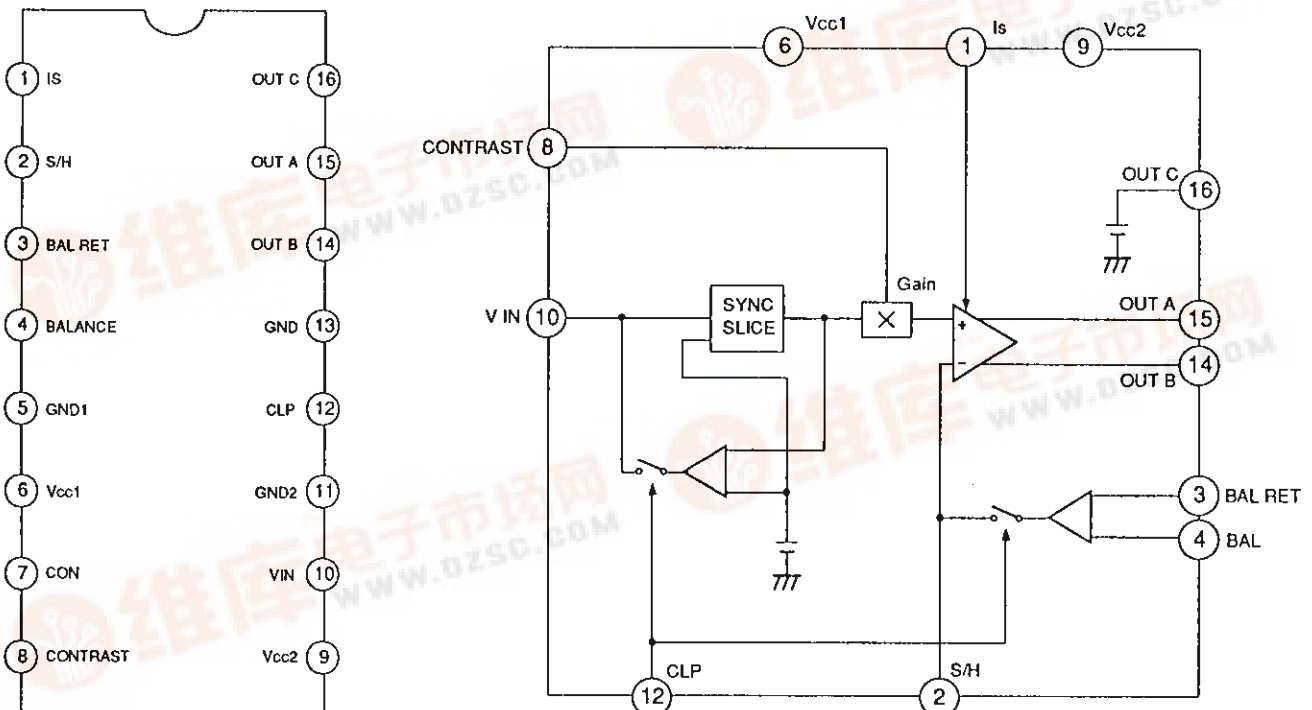

Sony reserves the right to change products and specifications without prior notice. This information does not convey any license by any implication or otherwise under any patents or other right. Application circuits shown, if any, are typical examples illustrating the operation of the devices. Sony cannot assume responsibility for any problems arising out of the use of these circuits.



Pin Description

Pin No.	Symbol	Pin voltage	Equivalent circuit	Description
1	IS	3V		Determines a reference current source. Connect a 15 kΩ metal film resistor between Pin 1 and GND.
2	S/H	8V		Connect a capacitor for clamp.
3	BAL RET	4V		Inputs a feedback signal from the drive stage to stabilize the DC bias at cathode drive stage.
4	BALANCE	4V		Sets a output DC level.
8	CONTRAST	—		Contrast control. Control is possible between 0 to 5 V DC.
10	VIN	—		Video signal input.
12	CLP	—		Clamp pulse input.

Pin No.	Symbol	Pin voltage	Equivalent circuit	Description
14	OUT B			Negative polarity output signal.
15	OUT A			Positive polarity output signal.
16	OUT C	2.6V		2.6V power supply output.
6	Vcc1	12V		Supply voltage for control system.
9	Vcc2	12V		Supply voltage for pre-amplifier block.
5	GND1	0		GND for control system.
11	GND2	0		GND for pre-amplifier block.
7	CON	0		Connect to GND.

Electrical Characteristics Measurement Circuit

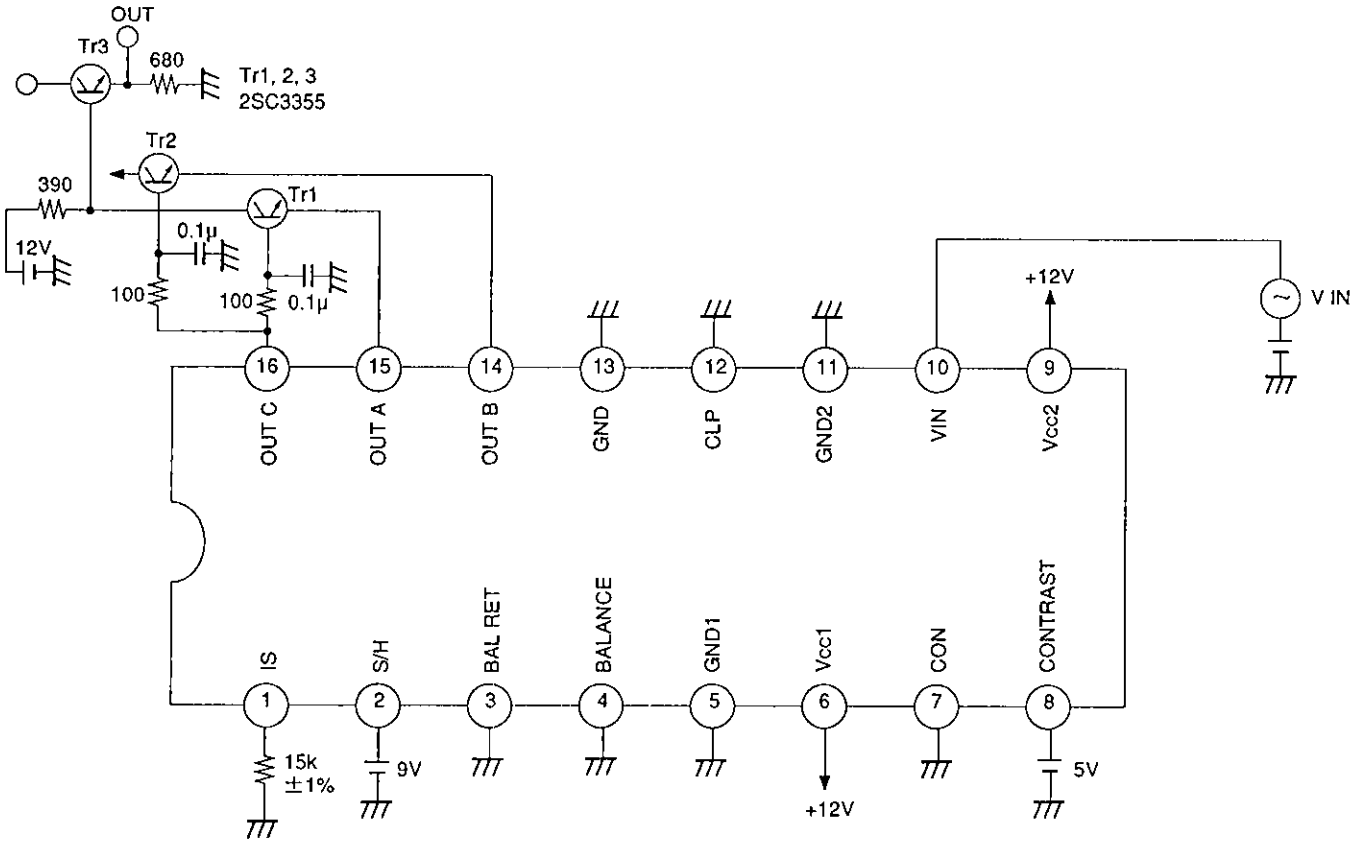

Electrical Characteristics

No.	Item	Symbol	Input conditions and measurements	Min.	Typ.	Max.	Unit
1	Supply current	ICC	Measure the inflow current at Pins 6 and 9 at no signal, no load.		33	45	mA
2	Frequency response	f150MHz	<p>R. G. B input</p> <p>R. G. B output</p> <p>Input: Input 0.7 VP-P, 1 MHz or 150 MHz and measure the output amplitude Vsig. Specifications can be obtained through the following formula, assuming Vsig1 for 1MHz and Vsig150 for 150MHz.</p> $f_{1-150} = 20 \log \left(\frac{V_{SIG150}}{V_{SIG1}} \right) \text{ (dB)}$ <p>* Measure Vsig peak to peak.</p>	- 3.0	+ 1.0	—	dB
3	Contrast control	CONTMAX	<p>R. G. B input</p> <p>R. G. B output</p> <p>Input: Measure the output amplitude Vsig at 0.7 VP-P, 1 MHz. The specifications can be obtained though the following formula.</p> $CONT_{MAX(MIN)} = 20 \log \left(\frac{V_{SIG}}{0.7} \right) \text{ (dB)}$	13.5	15.0	—	dB

Input/Output Pulse Waveforms and Description of Operation

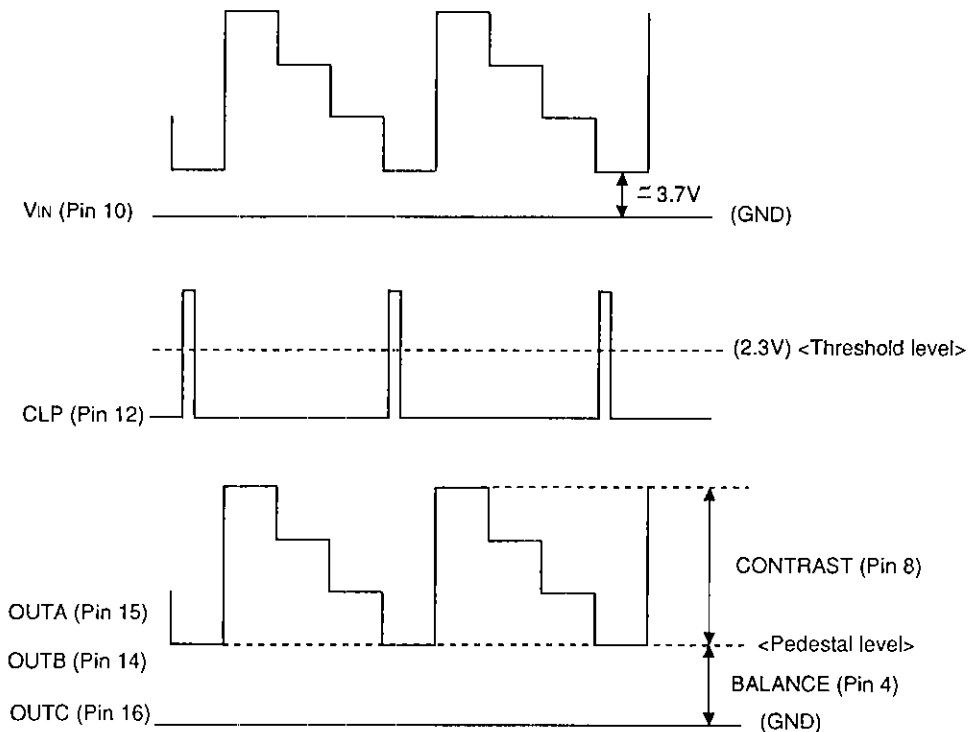

1. Contrast

Gain is controlled on the V_{IN} (Pin 10) input signal, using the DC voltage input from $CONTRAST$ (Pin 8). The control range is from -20 to 15 dB (typ.).

2. Pedestal Clamp

The pedestal level is clamped while $CLAMP$ (Pin 12) is high. The threshold level of the clamp pulse is approximately 2.3 V. Note that 300 ns are required for clamp time.

The output DC level can be varied by the DC input from $BALANCE$ (Pin 4). In this time, the emitter follower output at the external transistor should not be below 2 V or low.

3. The output signal is amplified by the external power amplifier and drives the CRT. The amplified signal voltage is fed back to Pin 3. Then, set the $R1$ and $R2$ values so that the pedestal level at Pin 3 is 4 ± 0.5 V.

Frequency response

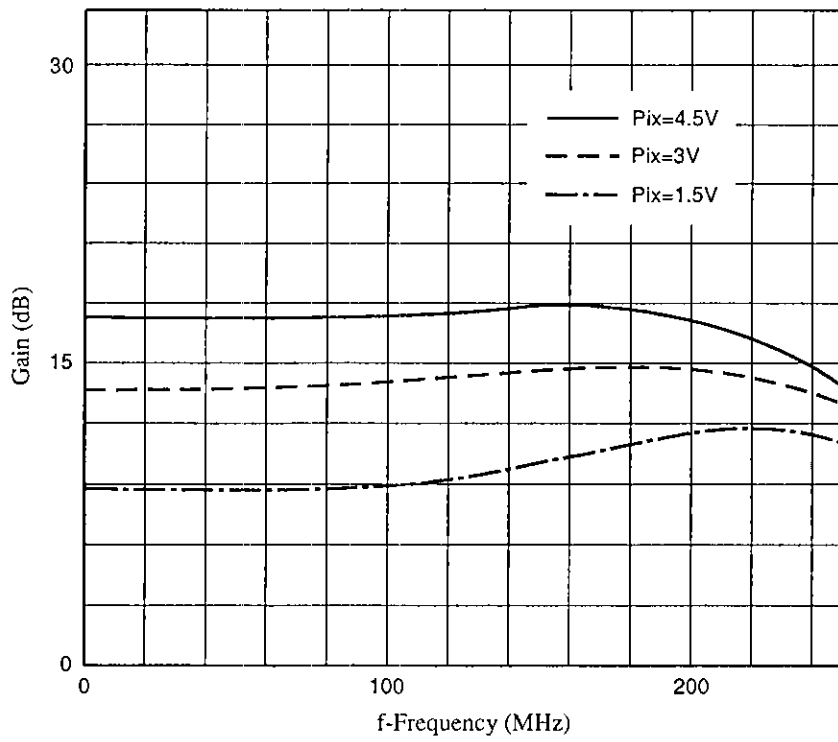

Gain control characteristics

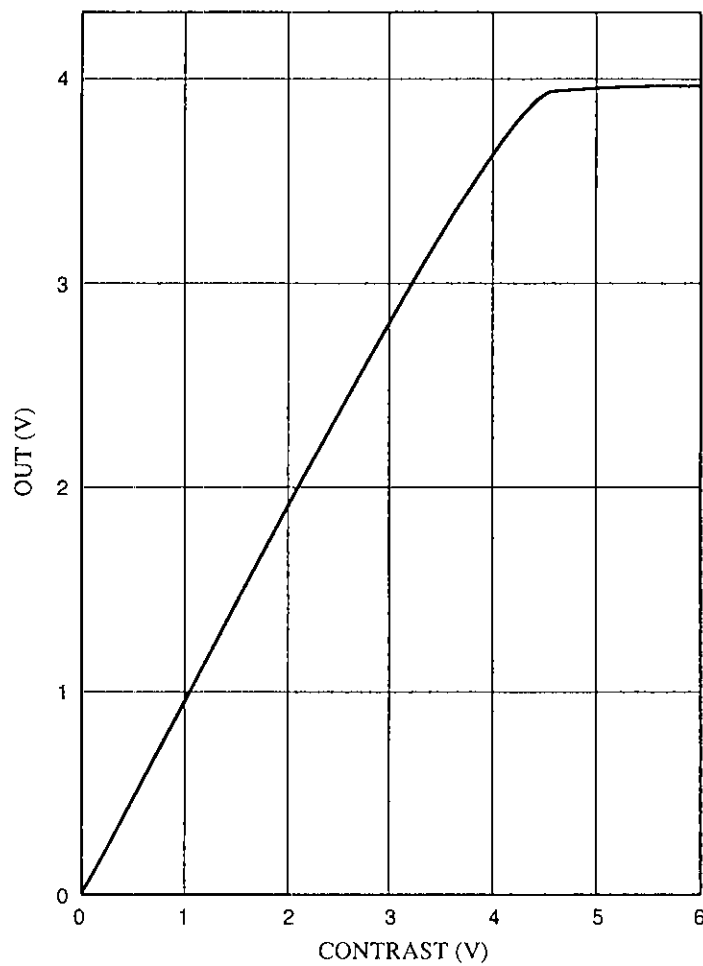

Package Outline Unit : mm

16pin DIP (Plastic) 300mil 1.0g

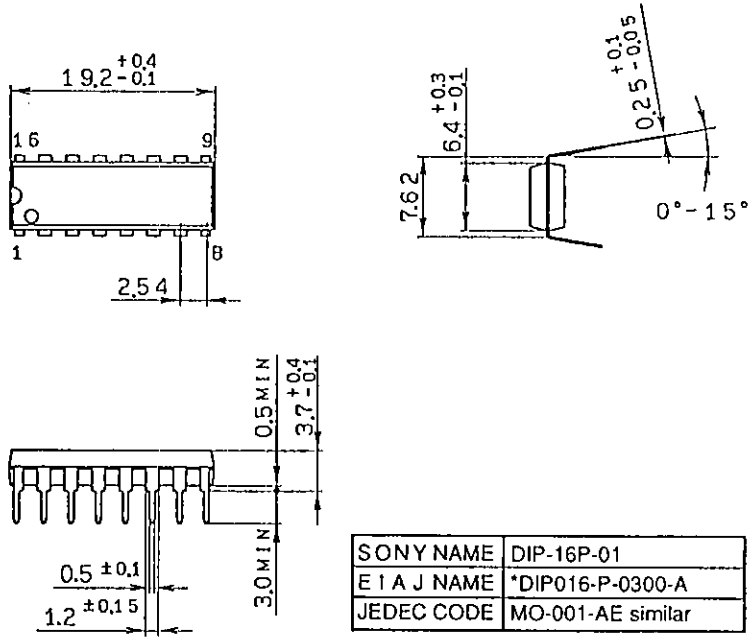

SONY NAME	DIP-16P-01
E I A J NAME	*DIP016-P-0300-A
JEDEC CODE	MO-001-AE similar