

SONY

CXA2038R

AFM Monaural Signal Processor for 8 mm VCR

Description

The CXA2038R is a bipolar IC designed as an AFM monaural signal processor for 8 mm VCRs. All functions necessary for AFM monaural are concentrated onto a single 64-pin LQFP.

Features

- Low supply voltage (3.15 V) design
- Low power consumption (Vcc=3.15 V)
 - Recording: 65 mW
 - Playback: 103 mW
- Built-in BPF (1.5 MHz)
- FM modulator center frequency made non-adjusting.
- Supports NTSC and PAL
- Enables both parallel and 3-line serial mode control
- Supports electronic volume (EVR) control

Applications

8 mm VCRs

Structure

Bipolar silicon monolithic IC

64 pin LQFP (Plastic)

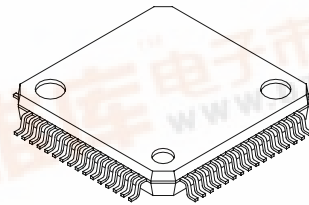

Absolute Maximum Ratings (Ta=25 °C)

- Supply voltage Vcc 7 V
- Operating temperature Topr -20 to +75 °C
- Storage temperature Tstg -65 to +150 °C
- Allowable power dissipation

P _D	1120	mW
----------------	------	----

 (When mounted on board)

Operating Conditions

- Recommended supply voltage

Vcc	3.15	V
VccH	4.75	V
- Supply voltage range

Vcc	3 to 5.25	V
VccH	4.5 to 5.25	V

 However, VccH ≥ Vcc



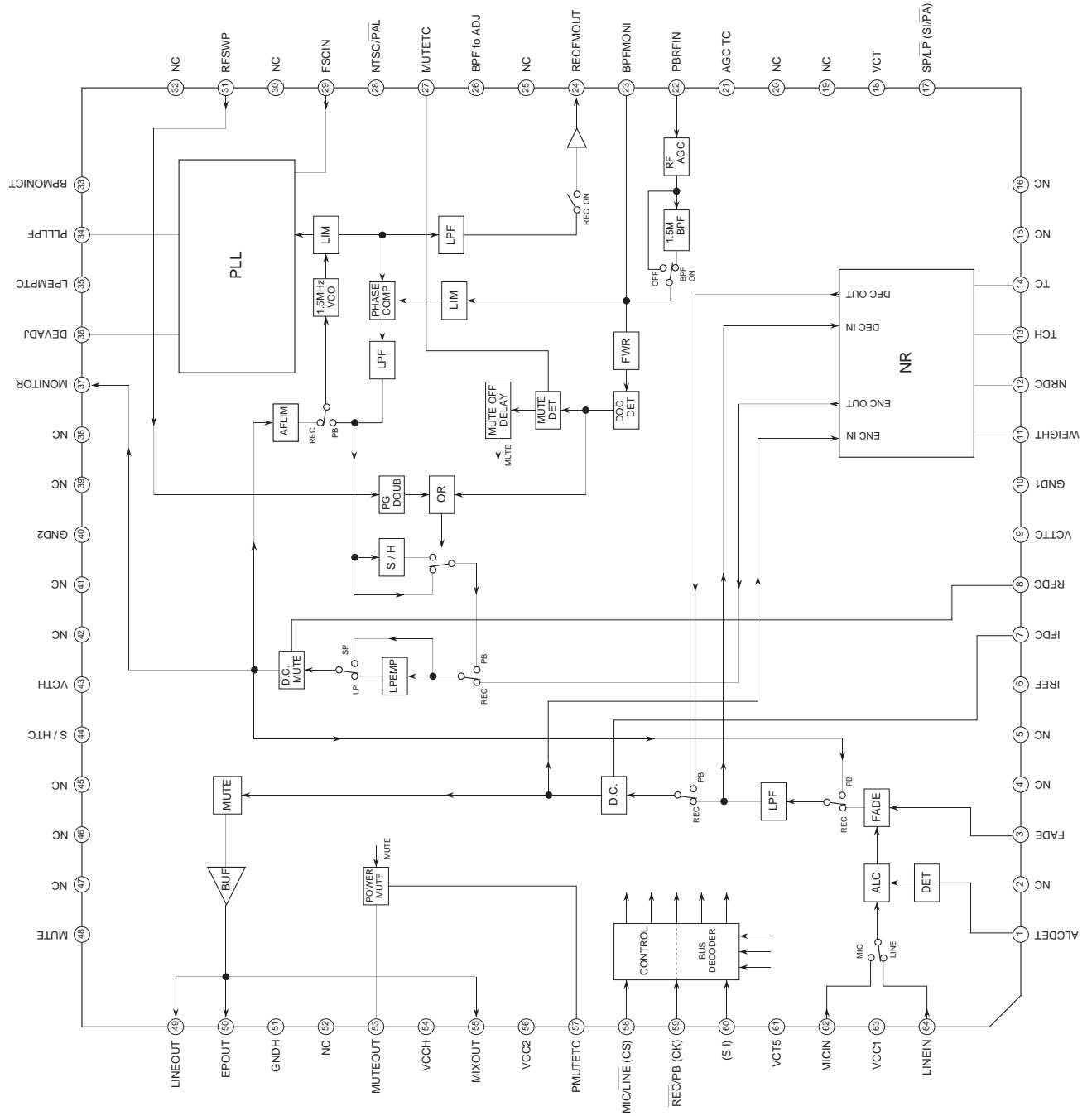

Block Diagram

Pin Description

(Vcc1, Vcc2=3.15 V, VccH=4.75 V, Ta=27 °C)

Pin No.	Symbol	Pin voltage		Equivalent circuit	Description
		DC	AC		
1	ALCDET	—	—		ALC time constant pin. ALC is OFF when this pin is connected to GND.
2	NC	—	—		
3	FADE	See attached sheet.	—		EVR control pin for fader. 0 to 0.5 V with fixed gain. Increasing the applied voltage lowers the gain and causes the fader to operate.
4	NC	—	—		
5	NC	—	—		

Pin No.	Symbol	Pin voltage		Equivalent circuit	Description
		DC	AC		
6	IREF	1.17 V	—		<p>Pin for generating the reference current. Connect a 47 kΩ external resistor. Be careful not to cause cross talk.</p>
7	IFDC	1.90 V	—		<p>Signal path DC monitor pin.</p>
8	RFDC	1.88 V	—		<p>Signal path DC monitor pin.</p>
9	VCT TC	1.83 V	—		<p>IC internal bias pin. Connect a decoupling capacitor.</p>
10	GND1	*1 0 V	—		<p>Audio system GND pin.</p>

*1 Externally applied voltage

Pin No.	Symbol	Pin voltage		Equivalent circuit	Description
		DC	AC		
11	WEIGHT	1.18 V	—		NR WEIGHT time constant pin.
12	NRDC	1.68 V	—		NR block DC monitor pin.
13	TCH	0.47 V	—		NR attack/recovery time constant pins.
14	TC	1.1 V	—		
15	NC	—	—		

Pin No.	Symbol	Pin voltage		Equivalent circuit	Description				
		DC	AC						
16	NC	—	—						
17	SI/PA (SP/LP)	—	—		<p>Serial/parallel (SP/LP) mode switching pin. When this pin is 4.3 V or more, the IC operates in serial control mode and mode control for the IC is performed by Pins 58 (CS), 59 (CK) and 60 (SI). When this pin is 3.5 V or less, the IC operates in parallel control mode as follows.</p> <table border="1"> <tr> <td>L (0 to 1 V)</td> <td>LP</td> </tr> <tr> <td>H (2 to 3.5 V) or OPEN</td> <td>SP</td> </tr> </table>	L (0 to 1 V)	LP	H (2 to 3.5 V) or OPEN	SP
L (0 to 1 V)	LP								
H (2 to 3.5 V) or OPEN	SP								
18	VCT	1.23 V	—		<p>IC internal bias pin. Connect a decoupling capacitor.</p>				
19	NC	—	—						
20	NC	—	—						

Pin No.	Symbol	Pin voltage		Equivalent circuit	Description
		DC	AC		
21	RFAGC TC	2.3 V	—		Pin for deciding RFAGC time constant.
22	PBRFIN	—			Input pin for PB RF signal. The reference input level is approximately 200 mVp-p (Y + C + AFM). Note that the reference input level for the AFM component is 15 mVp-p.
23	BPFMONI	1.0 V			Pin for monitoring the BPF output. Connect a 4.7 kΩ external resistor.
24	RECFMOUT	0.9 V			Recording FM modulated audio output pin.
25	NC	—	—		

Pin No.	Symbol	Pin voltage		Equivalent circuit	Description				
		DC	AC						
26	BPF f0 ADJ	See attached sheet.	—		Pin for varying the BPF fo. Non-adjusting mode when 0 to 0.8 V ($V_{CC} = 3.15$ V).				
27	MUTETC	2.3 V	—		Time constant pin for determining the MUTE OFF delay time.				
28	NTSC/PAL	—	—		<p>NTSC/PAL switching pin during parallel mode.</p> <table border="1"> <tr> <td>L (0 to 1 V)</td> <td>PAL</td> </tr> <tr> <td>H (2 V to V_{CC1})</td> <td>NTSC</td> </tr> </table>	L (0 to 1 V)	PAL	H (2 V to V_{CC1})	NTSC
L (0 to 1 V)	PAL								
H (2 V to V_{CC1})	NTSC								
29	Fsc IN	1.53 V	 Reference input 300 mVp-p		<p>fsc input pin.</p> <p>The input level is 200 to 500 mVp-p.</p> <p>During NTSC: 3.579545 MHz</p> <p>During PAL: 4.433619 MHz</p>				
30	NC	—	—						

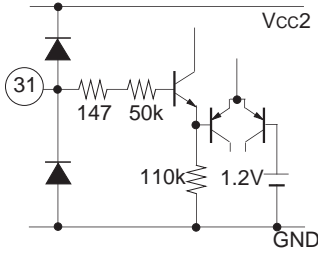
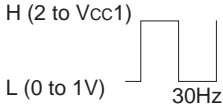
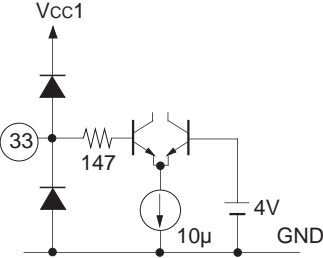
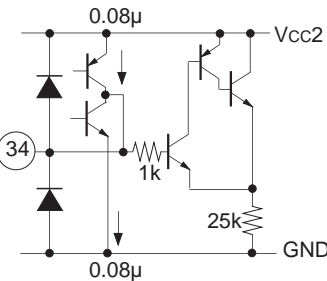
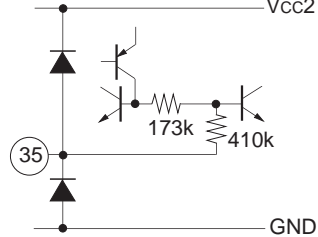
Pin No.	Symbol	Pin voltage		Equivalent circuit	Description				
		DC	AC						
31	RFSWP	—			<p>RFSWP input pin.</p> 				
32	NC	—	—						
33	BPFMONI CTL	—	—		<p>BPF ON/OFF switch control pin.</p> <table border="1" data-bbox="1066 1196 1445 1272"> <tr> <td>L (0 to 3.5 V) or OPEN</td> <td>BPF ON</td> </tr> <tr> <td>H2 (4.3 V to VccH)</td> <td>BPF OFF</td> </tr> </table>	L (0 to 3.5 V) or OPEN	BPF ON	H2 (4.3 V to VccH)	BPF OFF
L (0 to 3.5 V) or OPEN	BPF ON								
H2 (4.3 V to VccH)	BPF OFF								
34	PLLLPF	—	—		<p>PLL time constant pin. Since this pin has a small attraction and discharge current, signals should be received with high impedance when monitoring this pin. Also, be careful not to cause cross talk.</p>				
35	LPEMP TC	1.87 V	—		<p>LPEMP time constant pin. Be careful not to cause cross talk.</p>				

Pin No.	Symbol	Pin voltage		Equivalent circuit	Description
		DC	AC		
36	DEVADJ	See attached sheet.	—		Deviation adjusting pin. The variable width is from 0 to Vcc1.
37	MONI	1.84 V	 Reference output -15 dBm*2		Pin for monitoring the signal before modulation during recording and after demodulation during playback.
38	NC	—	—		
39	NC	—	—		
40	GND2	*1 0 V	—		RF system GND pin.

*1 Externally applied voltage

*2 0dBm=2.19 Vp-p

Pin No.	Symbol	Pin voltage		Equivalent circuit	Description
		DC	AC		
41	NC	—	—		
42	NC	—	—		
43	VCTH	1.89 V	—		RF system reference bias pin. Connect a decoupling capacitor.
44	SHTC	1.7 V	—		S/H time constant pin.
45	NC	—	—		

Pin No.	Symbol	Pin voltage		Equivalent circuit	Description				
		DC	AC						
46	NC	—	—						
47	NC	—	—						
48	MUTE ON/OFF	—	—		<p>Mute control pin.</p> <table border="1"> <tr> <td>L (0 to 1 V)</td> <td>MUTE OFF</td> </tr> <tr> <td>H (2 V to Vcc1) or OPEN</td> <td>MUTE ON</td> </tr> </table> <p>Mute control is possible during both serial and parallel modes.</p>	L (0 to 1 V)	MUTE OFF	H (2 V to Vcc1) or OPEN	MUTE ON
L (0 to 1 V)	MUTE OFF								
H (2 V to Vcc1) or OPEN	MUTE ON								
49	LINE OUT	2.01 V	<p>Reference output -7 dBm *1</p>		<p>LINEOUT pin. Set the load to 47 kΩ or more.</p>				
50	EPOUT	2.01 V	<p>Reference output -7 dBm *1</p>		<p>EPOUT pin. This pin can drive a load of 120 Ω.</p>				

*2 0dBm=2.19 Vp-p

Pin No.	Symbol	Pin voltage		Equivalent circuit	Description
		DC	AC		
51	GNDH	*1 0 V	—		Output buffer system GND pin.
52	NC	—	—		
53	MUTEOUT	0 V	—		MUTEOUT pin. This pin outputs current during muting and power ON/OFF to operate the external SW Tr.
54	VccH	*1 4.75 V	—		Output buffer system power supply pin.
55	MIXOUT	2.01 V	 Reference output -7 dBm *2		MIXOUT pin. Set the load to 47 kΩ or more.

*1 Externally applied voltage

*2 0dBm=2.19 Vp-p

Pin No.	Symbol	Pin voltage		Equivalent circuit	Description				
		DC	AC						
56	Vcc2	*1 3.15 V	—		RF system power supply pin.				
57	PMUTETC	4.75 V	—		Time constant pin for deciding the power ON/OFF mute time.				
58	MIC/LINE (CS)	—	—		<p>During parallel operation: MIC/LINE switching pin.</p> <table border="1"> <tr> <td>L (0 to 1 V) or OPEN</td> <td>LINE</td> </tr> <tr> <td>H (2 V to Vcc1)</td> <td>MIC</td> </tr> </table> <p>During serial operation: CS input pin.</p>	L (0 to 1 V) or OPEN	LINE	H (2 V to Vcc1)	MIC
L (0 to 1 V) or OPEN	LINE								
H (2 V to Vcc1)	MIC								
59	REC/PB (CK)	—	—		<p>During parallel operation: REC/PB switching pin.</p> <table border="1"> <tr> <td>L (0 to 1 V) or OPEN</td> <td>REC</td> </tr> <tr> <td>H (2 V to Vcc1)</td> <td>PB</td> </tr> </table> <p>During serial operation: CK input pin.</p>	L (0 to 1 V) or OPEN	REC	H (2 V to Vcc1)	PB
L (0 to 1 V) or OPEN	REC								
H (2 V to Vcc1)	PB								
60	SI	—	—		During serial operation: SI input pin.				

*1 Externally applied voltage

Pin No.	Symbol	Pin voltage		Equivalent circuit	Description
		DC	AC		
61	VCT5	2.02 V	—		IC internal bias pin. Connect a decoupling capacitor.
62	MICIN	1.16 V	 Reference input -38 dBm *2		Microphone input pin. Standard input level: -38 dBm. This pin has a small input signal level and high input impedance. Therefore, be careful not to cause cross talk with other signals.
63	Vcc1	*1 3.15 V	—		Audio system power supply pin.
64	LINE IN	1.16 V	 Reference input -38 dBm *2		Line input pin. Standard input level: -38 dBm. This pin has a small input signal level and high input impedance. Therefore, be careful not to cause cross talk with other signals.

*1 Externally applied voltage

*2 0dBm=2.19 Vp-p

No.	Item	Symbol	Measurement input signal conditions		Reference signal source			Control voltage						Switch condition, normally set to "b"										Mode condition	Measurement method	Ratings			Unit																	
			Input pin	Level	Frequency	Input pin	Level	Frequency	V3	V26	V33	V36	V44	1	3	22	29	31	33	44	62	64	Min.			Typ.	Max.																			
25	NR encode frequency response	FNR14	SG62	-38 dBm	10 kHz																																3.9	4.9	5.9	dB						
26	REC LP frequency response 1	FLP2	SG62	-38 dBm	2 kHz																																	1.6	2.1	2.5	dB					
27	REC LP frequency response 2	FLP10	SG62	-38 dBm	10 kHz																																			2.5	3.0	3.5	dB			
28	Oscillator frequency 1.5 MHz (NTSC)	FVCO1	SG29	200 mVpp	3.579545 MHz											a																								1.4995	1.5	1.5005	MHz			
29	Oscillator frequency 1.5 MHz (PAL)	FVCO2	SG29	200 mVpp	4.433619 MHz											a																								1.4995	1.5	1.5005	MHz			
30	REC FM output level	VFML				SG29	200 mVpp	3.579545 MHz								a																						187	208	229	mVpp					
31	REC FM output secondary distortion	VFMH1				SG29	200 mVpp	3.579545 MHz								a																										-45	-25	dB		
32	REC FM output tertiary distortion	VFNH2				SG29	200 mVpp	3.579545 MHz								a																											-50	-30	dB	
33	AF LIM characteristics	VAFLM	SG62	-18 dBm	10 kHz	SG29	200 mVpp	3.579545 MHz								a																									91	110	130	kHz		
34	DEV variable width 1.5 M	VDEV	SG62	-38 dBm	1 kHz	SG29	200 mVpp	3.579545 MHz								a																									0.1		2.9	V		
35	Reference FM modulation distortion	VRECH	SG62	-38 dBm	1 kHz	SG29	200 mVpp	3.579545 MHz								a																													0.4	%
36	RF AGC level 1	VAGCL1	SG22	150 mVpp	7 MHz	SG29	200 mVpp	3.579545 MHz								a																													110	mVpp

No.	Item	Symbol	Measurement input signal conditions		Reference signal source		Control voltage						Switch condition, normally set to "b,"							Mode condition	Measurement point	Measurement method	Ratings			Unit							
			Input pin	Level	Frequency	Input pin	Level	Frequency	V3	V26	V33	V36	V44	1	3	22	29	31	33				44	62	64		Min.	Typ.	Max.				
37	RFAGC level 2	VAGCL2	SG22	300 mV/pp	7 MHz	SG29	200 mV/pp	3.579545 MHz							a	a								166		mVp-p							
38	RFAGC level 3	VAGCL3	SG22	600 mV/pp	7 MHz	SG29	200 mV/pp	3.579545 MHz							a	a										167	mVp-p						
39	BPF ADJ voltage	VBPAJ	SG22	15 mV/pp	1.4 MHz, 1.6 MHz	SG29	200 mV/pp	3.579545 MHz	Adjusting						a	a								1.2	3	V							
40	BPF MONI level 1.5 MHz	VBPML	SG22	15 mV/pp	1.5 MHz	SG29	200 mV/pp	3.579545 MHz	VBPAJ value						a	a											110	mVp-p					
41	Frequency response 0.8 M/1.5 M	FBP0.8	SG22	15 mV/pp	0.8 MHz	SG29	200 mV/pp	3.579545 MHz	VBPAJ value						a	a													-28	dB			
42	Frequency response 1.3 M/1.5 M PBRFIN → BPFMONI	FBP1.3	SG22	15 mV/pp	1.3 MHz	SG29	200 mV/pp	3.579545 MHz	VBPAJ value						a	a														-8	dB		
43	Frequency response 1.4 M/1.5 M PBRFIN → BPFMONI	FBP1.4	SG22	15 mV/pp	1.4 MHz	SG29	200 mV/pp	3.579545 MHz	VBPAJ value						a	a														-2	dB		
44	Frequency response 1.6 M/1.5 M PBRFIN → BPFMONI	FBP1.6	SG22	15 mV/pp	1.6 MHz	SG29	200 mV/pp	3.579545 MHz	VBPAJ value						a	a														-2	dB		
45	Frequency response 1.7 M/1.5 M PBRFIN → BPFMONI	FBP1.7	SG22	15 mV/pp	1.7 MHz	SG29	200 mV/pp	3.579545 MHz	VBPAJ value						a	a														-15	dB		
46	Frequency response 2.5 M/1.5 M PBRFIN → BPFMONI	FBP2.5	SG22	15 mV/pp	2.5 MHz	SG29	200 mV/pp	3.579545 MHz	VBPAJ value						a	a														-31	dB		
47	Demodulation level	VPBL	SG22	15 mVpp-p DE/460 kHz fs=1 kHz	1.5 MHz	SG31 SG29	3 Vp-p 200 mVpp-p	30 Hz 3.579545 MHz	VBPAJ value	VDEV value					a	a														-7.8	-5.8	dBm	
48	Demodulation distortion factor	HPB	SG22	15 mVpp-p DE/460 kHz fs=1 kHz	1.5 MHz	SG31 SG29	3 Vp-p 200 mVpp-p	30 Hz 3.579545 MHz	VBPAJ value	VDEV value					a	a															0.25	0.5	%

No.	Item	Symbol	Measurement input signal conditions			Reference signal source				Control voltage				Switch condition, normally set to "b"								Mode condition	Measurement method	Ratings			Unit							
			Input pin	Level	Frequency	Input pin	Level	Frequency	V3	V26	V33	V36	V44	1	3	22	29	31	33	44	62			64	Min.	Typ.		Max.						
49	Demodulation noise	NPB	SG22	15 mVp-p	1.5 MHz	SG31 SG29	3 Vp-p 200 mVp-p	30 Hz 3.579545MHz	VBPJAJ value	VDEJ value						a	a	a								P49	A weight			-75	dBm			
50	DOC detection sensitivity a (during SF)	VDOC1	SG22	See Fig. 1	1.5 MHz	SG29	200 mVp-p	3.579545MHz	VBPJAJ value	2.4 V					a											P37	Obtain the value for a where 15 mVp-p = 0 dB. See Fig. 1.			-17.5 -7.5	dB			
51	Hysteresis b (during SF)	VDOC2	SG22	See Fig. 1	1.5 MHz 30 %AM	SG29	200 mVp-p	3.579545MHz	VBPJAJ value	2.4 V					a											P37	Obtain the ratio of b/a. VDOC2/VDOC1 See Fig. 1.	1	2	4.5	dB			
52	DOC detection sensitivity a (during LP)	VDOC3	SG22	See Fig. 1	1.5 MHz 30 %AM	SG29	200 mVp-p	3.579545MHz	VBPJAJ value	2.4 V					a											P37	Obtain the value for a where 15 mVp-p = 0 dB. See Fig. 1.			-20.5 10.5	dB			
53	MUTE OFF DELAY T1	TMUON	SG22	See Fig. 2	1.5 MHz Tone Burst	SG31 SG29	3 Vp-p 200 mVp-p	30 HZ 3.579545MHz	VBPJAJ value						a											P49				420	530	640	µs	
54	MUTE hold time T2	TMUOF	SG22	See Fig. 2	1.5 MHz Tone Burst	SG31 SG29	3 Vp-p 200 mVp-p	30 HZ 3.579545MHz	VBPJAJ value						a												P49				120	150	180	ms
55	PG doubler width (See Fig. 3.)	TPGH	SG22	15 mVp-p	1.5 MHz	SG31 SG29	3 Vp-p 200 mVp-p	30 Hz 3.579545MHz	VBPJAJ value	2.4 V					a																5.5	7.5	9.5	µs
56	PG doubler delay (See Fig. 3.)	TPGD	SG22	15 mVp-p	1.5 MHz	SG31 SG29	3 Vp-p 200 mVp-p	30 Hz 3.579545MHz	VBPJAJ value	2.4 V					a																1	2	3	µs
57	POWER ON/OFF NOISE	NPMU																										Measure the EE system output DC level difference during power ON/OFF.	-100	0	+100	mVp-p		
58	CS, CK, SIN input Low level	VSIL	58 59 60		DC																					P58 P59 P60				0	1	V		
59	CS, CK, SIN input High level	VSIH	58 59 60		DC																					P58 P59 P60				2	V _∞	V		
60	MUTE ON/OFF Low level	V48L	48		DC																					P48				0	1	V		

No.	Item	Symbol	Measurement input signal conditions		Reference signal source			Control voltage				Switch condition, normally set to "b"							Mode condition	Measurement point	Measurement method	Ratings			Unit								
			Input pin	Level	Frequency	Input pin	Level	Frequency	V3	V26	V33	V36	V44	1	3	22	29	31				33	44	62		64	Min.	Typ.	Max.				
61	MUTE ON/OFF High level	V48H	48		DC																											V _{cc}	V
62	Serial/parallel Low level	V17SL	17		DC																											3.5	V
63	Serial/parallel High level	V17SH	17		DC																											V _{cc}	V
64	SP/LP Low level	V17L	17		DC																											1	V
65	SP/LP High level	V17H	17		DC																											3.5	V
66	NTSC/PAL Low level	V28L	28		DC																											1	V
67	NTSC/PAL High level	V28H	28		DC																											V _{cc}	V
68	MUTE ON/OFF Low level	V48L	48		DC																											1	V
69	MUTE ON/OFF High level	V48H	48		DC																											V _{cc}	V
70	MIC/LINE Low level	V58L	58		DC																											1	V
71	MIC/LINE High level	V58H	58		DC																											V _{cc}	V
72	PB/REC Low level	V59L	59		DC																											1	V
73	PB/REC High level	V59H	59		DC																											V _{cc}	V

Mode Condition Table

Electrical characteristics measurement circuit mode table

Mode condition	Bus decoder condition table during serial										Condition table during parallel							Mode contents
	Value	bit 0-5	bit 6	bit 7-10	bit 11	bit 12	bit 13	bit 14	bit 15	Value	V58	V17	V28	V48	V59			
	0	—	—	—	LINE	LP	PAL	MUTE	REC	L	LINE	LP	PAL	MUTE	REC			
a	1	—	—	—	MIC	SP	NTSC	0	0	L	H	H	H	L	L	REC (LINE)		
b	—	0	0	0	0	1	1	0	0	H	H	H	H	L	L	REC (MIC)		
c	—	0	0	0	1	1	1	0	1	H	H	H	H	L	H	PB		
d	—	0	0	0	1	0	1	0	0	H	L	H	H	L	L	LP MODE		
e	—	0	0	0	1	1	0	0	0	H	H	L	L	L	L	PAL MODE		
f	—	0	0	0	1	1	1	1	0	H	H	H	H	H	L	REC MUTE		
g	—	0	0	0	1	1	1	1	1	H	H	H	H	H	H	PB MUTE		

Note)

- bit 6 should be "0".
- During serial control, set switches 58, 59 and 60 to "a", and V17 to 4.3 to VccH.
During parallel control, set switches 58, 59 and 60 to "b", and V17 to L (0 to 1 V) during LP and H (2 V to 3.5 V) during SP.

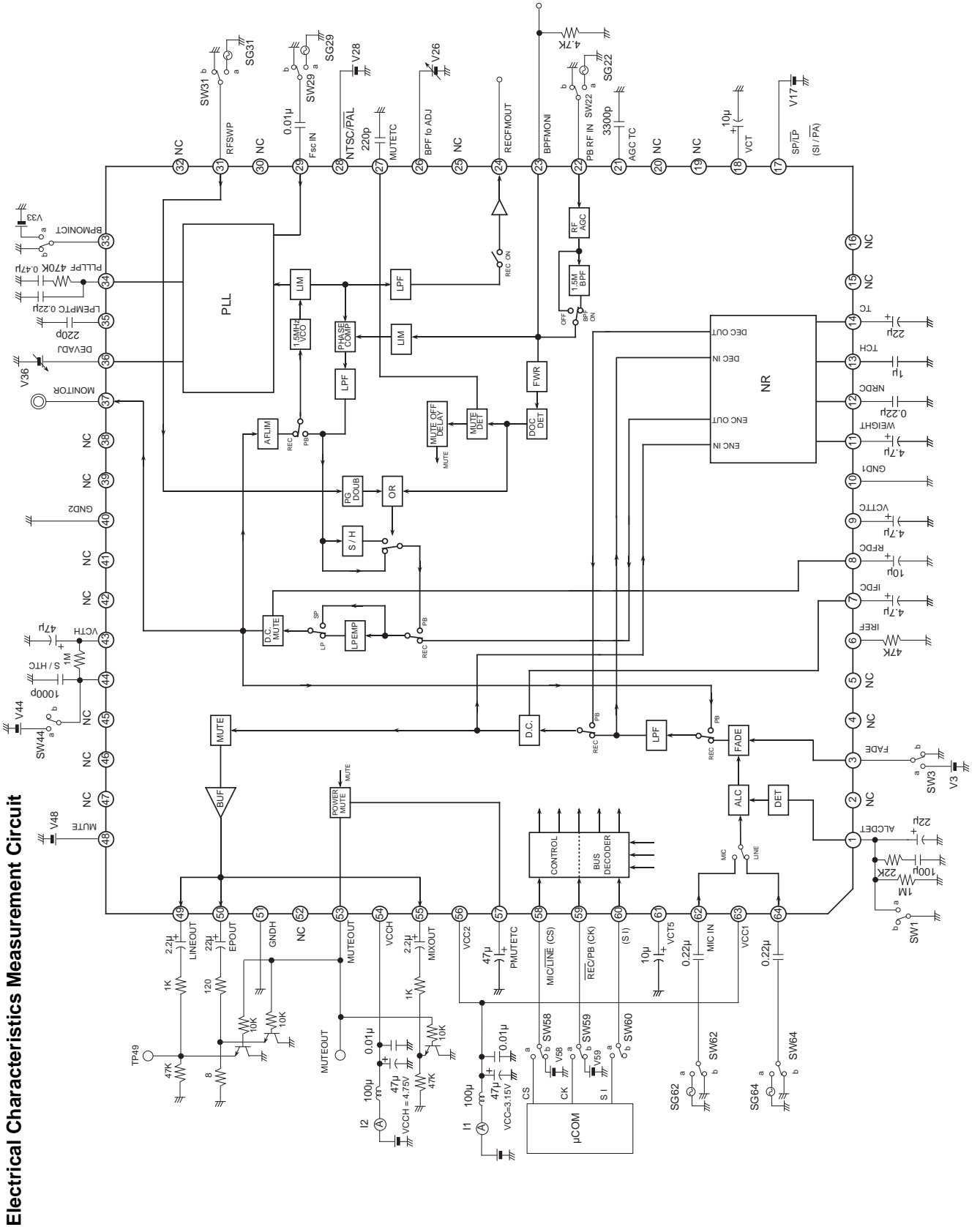

Electrical Characteristics Measurement Circuit

Input/Output Waveform

Fig. 1

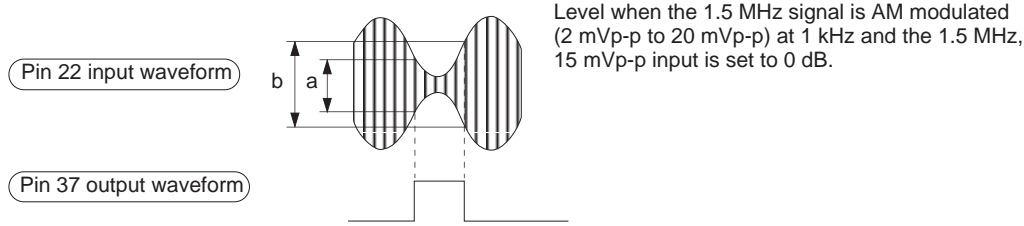

Fig. 2

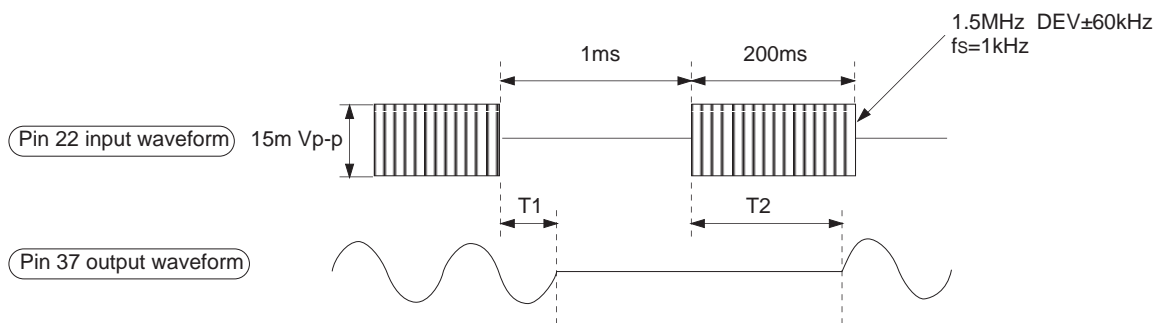
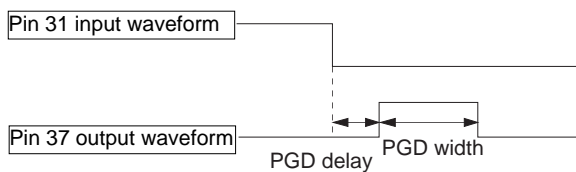

Fig. 3



Adjustment and measurement methods

- DEV adjustment method

Input the reference input (−38 dBm, 1 kHz) to the MIC input and adjust the voltage applied to Pin 36 so that the Pin 24 output reference frequency deflection is 1.5 MHz ±62.8 kHz.

When adjusting DEV, connect a 10 kΩ load resistor between Pin 24 and GND.

- Reference modulation distortion factor

Demodulate the Pin 24 output into the audio signal with the reference demodulator under the same conditions as for DEV adjustment above, then measure the distortion factor.

- BPF f0 adjustment method

Input 15 mVp-p, 1.4 MHz and 1.6 MHz signals to Pin 22 and adjust the voltage applied to Pin 26 so that the 1.4 MHz and 1.6 MHz levels output to Pin 23 are equal.

Note that since adjustment OFF mode results when the Pin 26 voltage is between 0 to 0.8 V, the BPF f0 should be adjusted with the Pin 26 voltage between 1.2 to 3 V (when Vcc1 = 3.15 V). When adjusting the BPF f0, connect a 4.7 kΩ load resistor between Pin 23 and GND.

Mode Control Tables

Parallel CTL mode table

Pin No.	Symbol	CTL voltage				
		LOW (0 to 1 V)	OPEN	HIGH1 (2 V to V _{cc1})	HIGH2 (2 V to 3.5V)	HIGH3 (4.3 V to V _{ccH})
17	SP/LP	LP	SP	—	SP	SERIAL*1
28	NTSC/PAL	PAL	—	NTSC	—	—
33	BPF ON/OFF	BPF ON	BPF ON	—	BPF ON	1.5 MBPFOFF
48	MUTE	MUTE OFF	MUTE ON	MUTE ON	—	—
58	MIC/LINE	LINE	LINE	MIC	—	—
59	REC/PB	REC	REC	PB	—	—

*1 When Pin 17 is 4.3 V or more, the IC operates in serial control mode.

Serial CTL mode table

When Pin 17 is 4.3 V or more, the IC operates in serial control mode.

bit No.	Control name	CTL value	Mode	Pin No.	Symbol	CTL voltage		
						LOW (0 to 1 V)	OPEN	HIGH (2 V to V _{cc})
0	—	—	—	58	CS	L	L	H
1	—	—	—	59	CK	L	L	H
2	—	—	—	60	SI	L	L	H
3	—	—	—					
4	—	—	—					
5	—	—	—					
6	—	L	—					
7	—	—	—					
8	—	—	—					
9	—	—	—					
10	—	—	—					
11	MIC/LINE switching	L H	LINEIN MICIN					
12	SP/LP switching	L H	LP SP					
13	NTSC/PAL switching	L H	PAL NTSC					
14	MUTE	L H	OFF MUTEON					
15	PB/REC	L H	REC PB					

Note) bit 6 should normally be set to

Input conditions

Item	Symbol	Min.	Typ.	Max.	Unit
Clock frequency	f _{ck}			800	kHz
Setup time	t _{su}	400			ns
Hold time	t _{HLD}	400			ns
CS fall time to SI start time	t ₁	2			μs
Final CK rise time to CS rise time	t ₂	2			μs

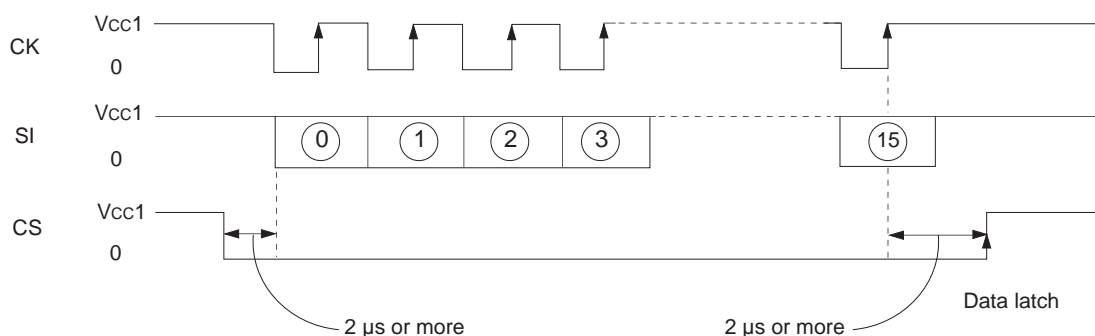

FADER characteristics A-Weight

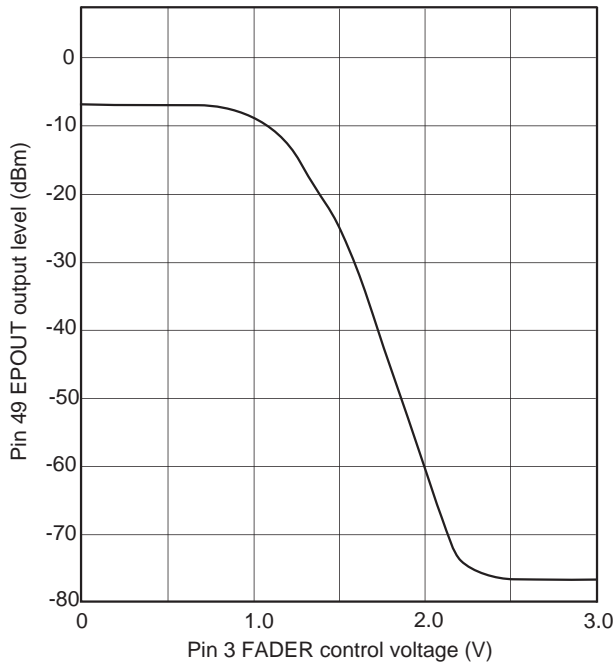

BPF fo characteristics

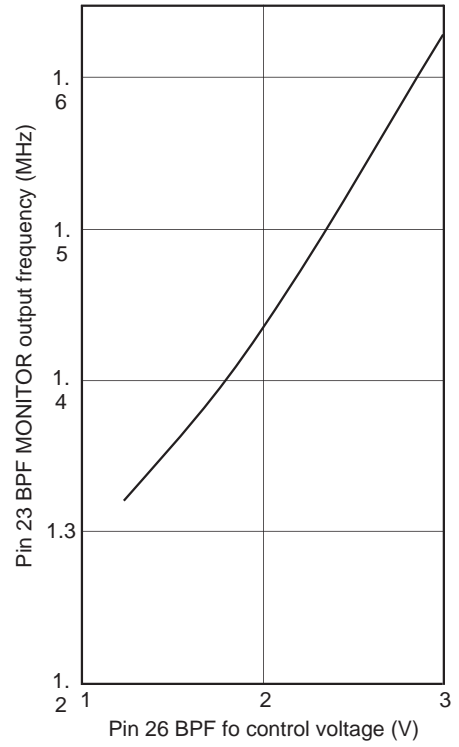

DEV width characteristics

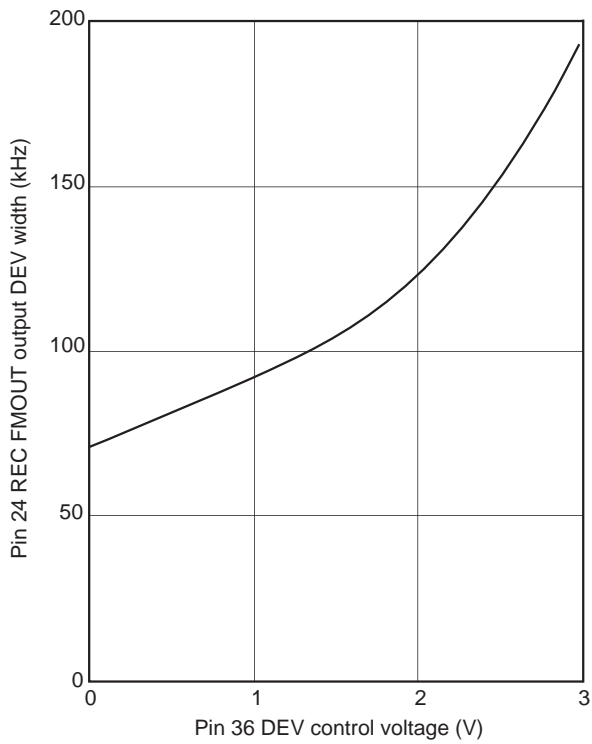

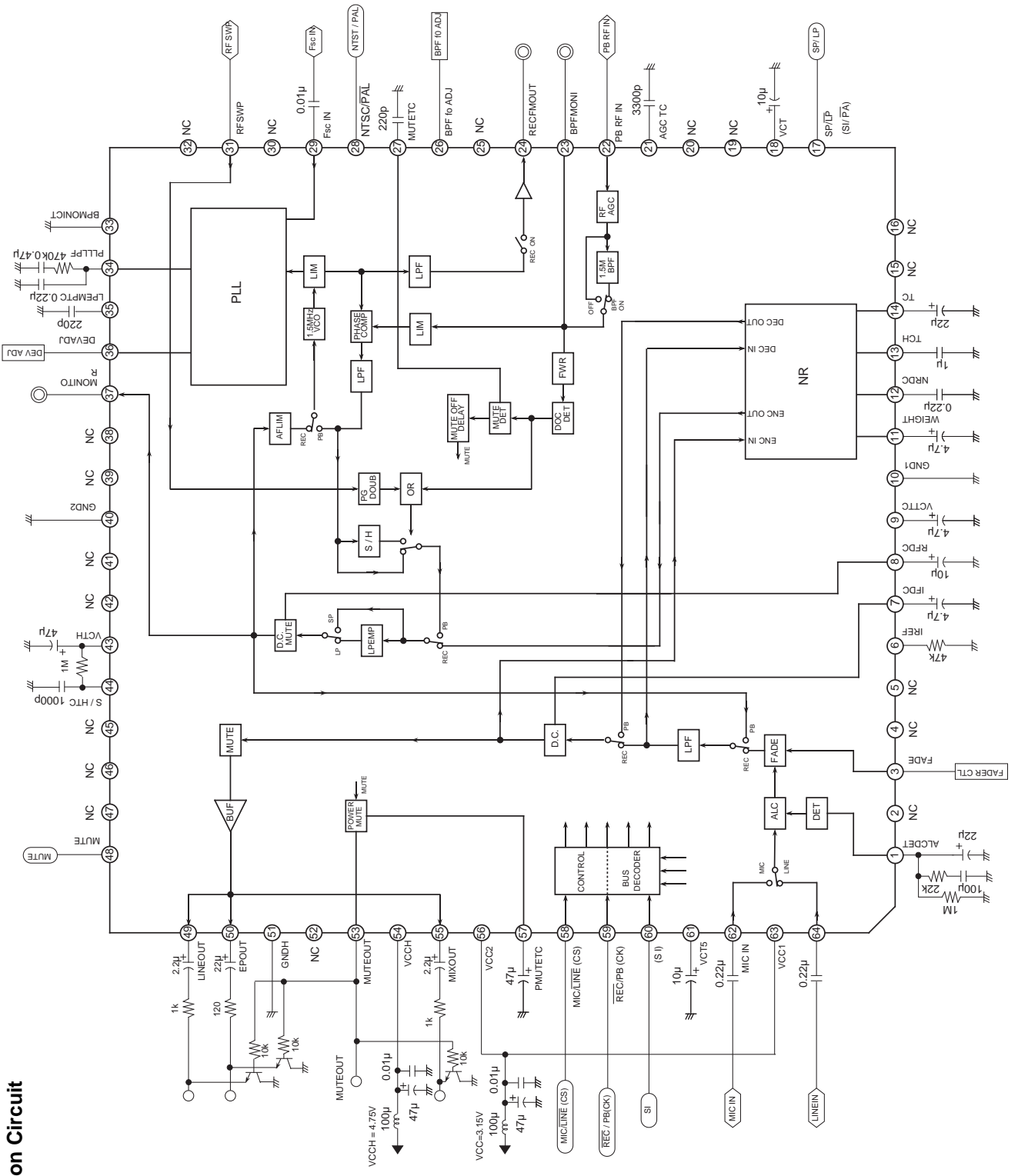

Application Circuit

Package Outline Unit : mm

64PIN LQFP (PLASTIC)

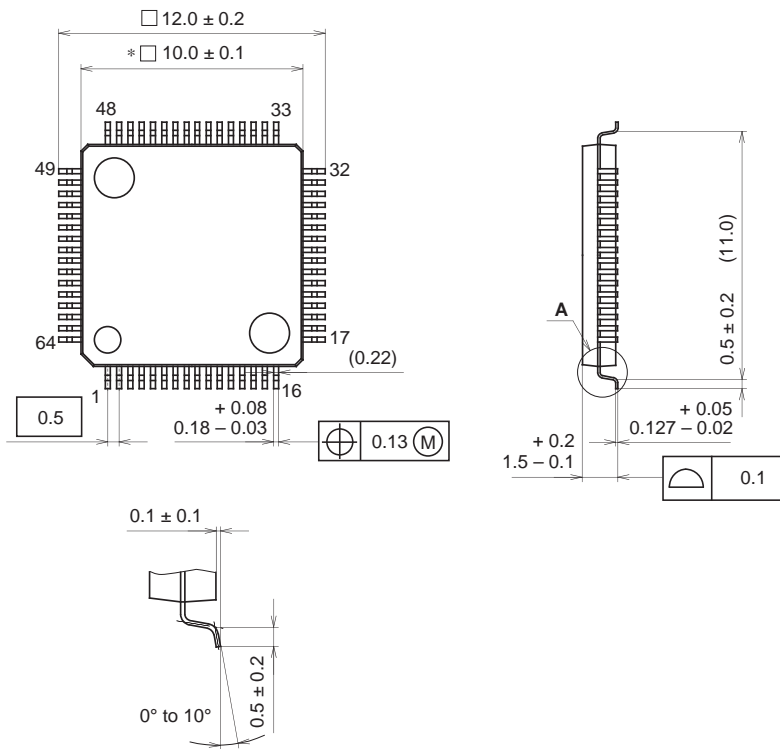

DETAIL A

NOTE: Dimension "*" does not include mold protrusion.

PACKAGE STRUCTURE

SONY CODE	LQFP-64P-L01
EIAJ CODE	LQFP064-P-1010
JEDEC CODE	_____

PACKAGE MATERIAL	EPOXY RESIN
LEAD TREATMENT	SOLDER/PALLADIUM PLATING
LEAD MATERIAL	42/COPPER ALLOY
PACKAGE MASS	0.3g