

**SONY**

**CXA2164Q**

**US Audio Multiplexing Decoder**

**Description**

The CXA2164Q is an IC designed as a decoder for the Zenith TV Multi-channel System and also corresponds with I<sup>2</sup>C BUS. Functions include stereo demodulation, SAP (Separate Audio Program) demodulation, dbx noise reduction, and sound processor. Various kinds of filters are built in this IC. Adjustment, mode control and sound processor control are all executed through I<sup>2</sup>C BUS.

**Features**

- Alignment-free VCO and filter
- Audio multiplexing decoder, dbx noise reduction decoder, sound processor
  - One external input
  - Volume control
 are all included in a single chip. Almost any sort of signal processing is possible through this IC.
- Input level, separation adjustments and each mode control are possible through I<sup>2</sup>C BUS.

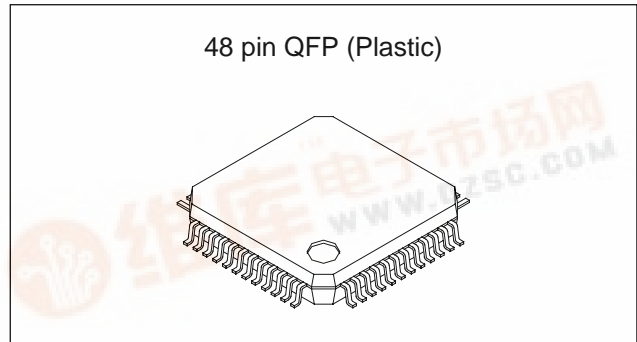

**Absolute Maximum Ratings** (Ta = 25°C)

- Supply voltage Vcc 11 V
- Operating temperature Topr -20 to +75 °C
- Storage temperature Tstg -65 to +150 °C
- Allowable power dissipation Pd 0.6 W

**Range of Operating Supply Voltage**

9 ± 0.5 V

**Applications**

TV, VCR and other decoding systems for US audio multiplexing TV broadcasting

**Structure**

Bipolar silicon monolithic IC

\* A license of the dbx-TV noise reduction system is required for the use of this device.

**Pin Configuration (Top View)**

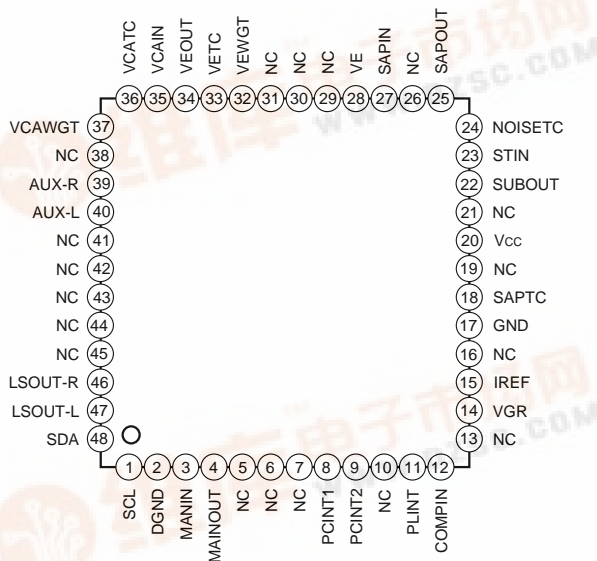

Block Diagram

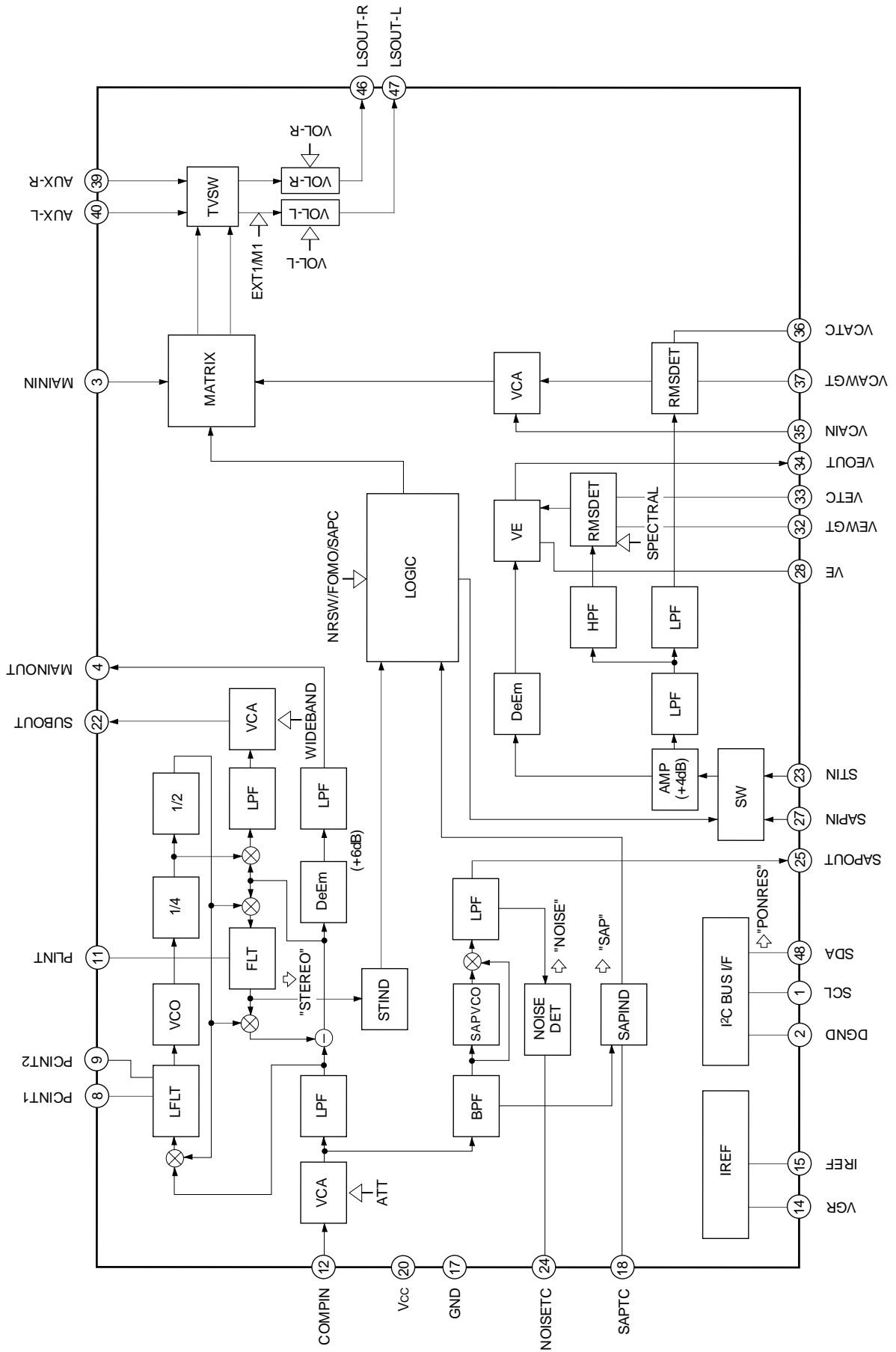

Pin Description





(Ta = 25°C, Vcc = 9V)

Pin No.	Symbol	Pin voltage	Equivalent circuit	Description
1	SCL	—		<p>Serial clock input pin.  <math>V_{IH} &gt; 3.0V</math>  <math>V_{IL} &lt; 1.5V</math></p>
2	DGND	—		<p>Digital block GND.</p>
3	MAININ	4.0V		<p>Input the (L + R) signal from MAINOUT (Pin 4).</p>
4	MAINOUT	4.0V		<p>(L + R) signal output pin.</p>
5	NC	—		<p>—</p>
6	NC	—		<p>—</p>
7	NC	—		<p>—</p>

Pin No.	Symbol	Pin voltage	Equivalent circuit	Description
8	PCINT1	4.0V		Stereo block PLL loop filter integrating pin.
9	PCINT2	4.0V		
10	NC	—		—
11	PLINT	5.1V		Pilot cancel circuit loop filter integrating pin. (Connect a 1μF capacitor between this pin and GND.)
12	COMPIN	4.0V		Audio multiplexing signal input pin.
13	NC	—		—

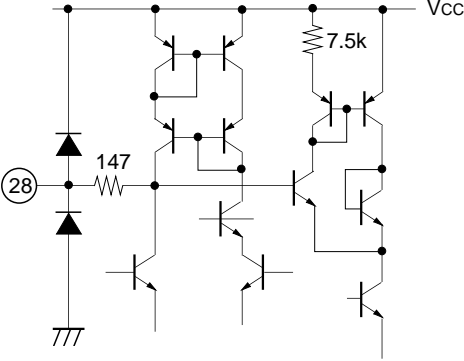



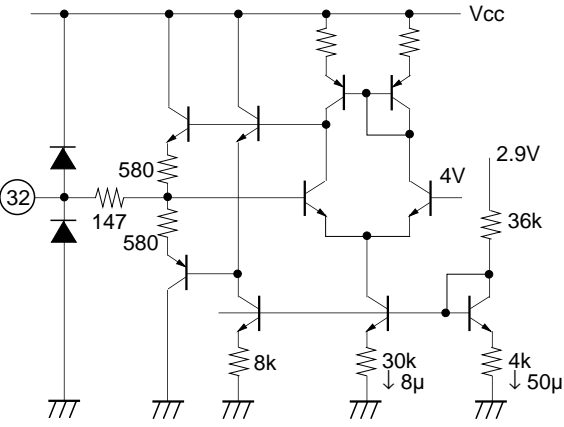
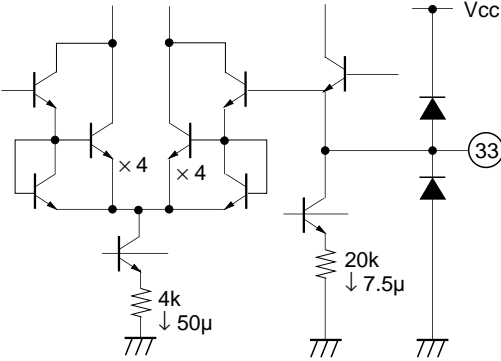

Pin No.	Symbol	Pin voltage	Equivalent circuit	Description
14	VGR	1.3V		Band gap reference output pin. (Connect a 10 $\mu$ F capacitor between this pin and GND.)
15	IREF	1.3V		Set the filter and VCO reference current. The reference current is adjusted with the BUS DATA based on the current which flows to this pin. (Connect a 62k $\Omega$ ( $\pm$ 1%) resistor between this pin and GND.)
16	NC	—		—
17	GND	—		Analog block GND.
18	SAPTC	4.5V		Set the time constant for the SAP carrier detection circuit. (Connect a 4.7 $\mu$ F capacitor between this pin and GND.)
19	NC	—		—
20	Vcc	—		Supply voltage pin.
21	NC	—		—

Pin No.	Symbol	Pin voltage	Equivalent circuit	Description
22	SUBOUT	4.0V		(L-R) signal output pin.
23	STIN	4.0V		Input the (L-R) signal from SUBOUT (Pin 22).
27	SAPIN	4.0V		Input the (SAP) signal from SAPOUT (Pin 25).
24	NOISETC	3.0V		Set the time constant for the noise detection circuit. (Connect a 4.7μF capacitor between this pin and GND.)
25	SAPOUT	4.0V		SAP FM detector output pin.

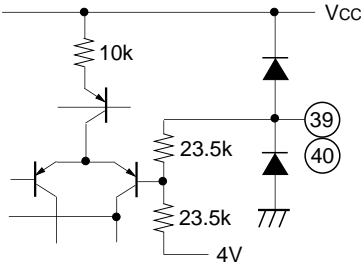
Pin No.	Symbol	Pin voltage	Equivalent circuit	Description
26	NC	—		—
28	VE	4.0V		Variable de-emphasis integrating pin. (Connect a 2700pF capacitor and a 3.3kΩ resistor in series between this pin and GND.)
29	NC	—		—
30	NC	—		—
31	NC	—		—
32	VEWGT	4.0V		Weight the variable de-emphasis control effective value detection circuit. (Connect a 0.047μF capacitor and a 3kΩ resistor in series between this pin and GND.)
33	VETC	1.7V		Determine the restoration time constant of the variable de-emphasis control effective value detection circuit. (The specified restoration time constant can be obtained by connecting a 3.3μF capacitor between this pin and GND.)

Pin No.	Symbol	Pin voltage	Equivalent circuit	Description
34	VEOUT	4.0V		<p>Variable de-emphasis output pin.                      (Connect a 4.7μF non-polar capacitor between Pins 34 and 35.)</p>
35	VCAIN	4.0V		<p>VCA input pin.                      Input the variable de-emphasis output signal from Pin 34 via a coupling capacitor.</p>
36	VCATC	1.7V		<p>Determine the restoration time constant of the VCA control effective value detection circuit.                      (The specified restoration time constant can be obtained by connecting a 10μF capacitor between this pin and GND.)</p>
37	VCAWGT	4.0V		<p>Weight the VCA control effective value detection circuit.                      (Connect a 1μF capacitor and a 3.9kΩ resistor in series between this pin and GND.)</p>

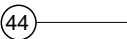

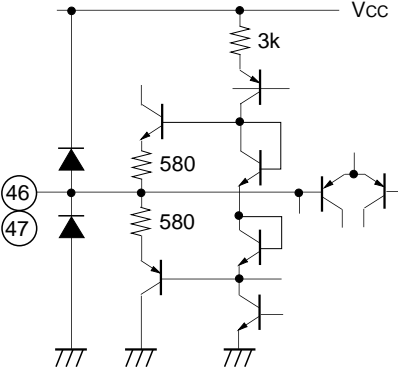
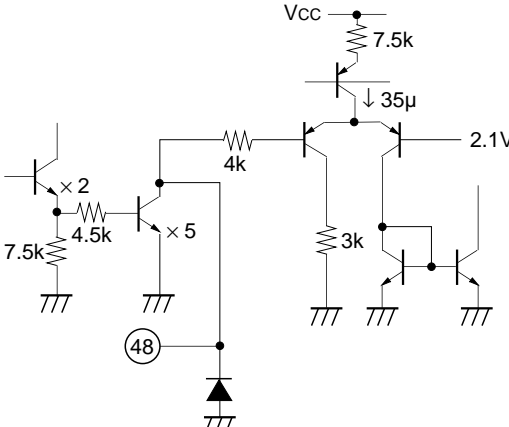
Pin No.	Symbol	Pin voltage	Equivalent circuit	Description
38	NC	—		—
39	AUX-R	4.0V		Right channel external input pin.
40	AUX-L	4.0V		Left channel external input pin.
41	NC	—		—
42	NC	—		—
43	NC	—		—
44	NC	—		—
45	NC	—		—
46	LSOUT-R	4.0V		LSOUT right channel output pin.
47	LSOUT-L	4.0V		LSOUT left channel output pin.
48	SDA	—		Serial data I/O pin. $V_{IH} > 3.0V$ $V_{IL} < 1.5V$

**Electrical Characteristics**

COMPIN input level

(100% modulation level)

Main (L + R) (Pre-Emphasis: OFF) = 245mVrms

SUB (L - R) (dbx-TV: OFF) = 490mVrms

Pilot = 49mVrms

SAP Carrier = 147mVrms

fH = 15.734kHz

(Ta = 25°C, Vcc = 9V)

No.	Item	Signal	Mode	Input pin	Input signal	Measurement conditions	Filter	Output pin	Min.	Typ.	Max.	Unit
1	Current consumption	Icc		—	No signal				23	32	43	mA
2	Main output level	Vmain	MONO	12	Mono 1kHz 100% mod. Pre-em. ON			46/47	440	490	540	mVrms
3	Main de-emphasis frequency characteristic	FCdeem	MONO	12	Mono 5kHz 30% mod. Pre-em. ON	20 log (‘5k/’1k’)		46/47	-1.2	0	1.0	dB
4	Main LPF frequency characteristic	FCmain	MONO	12	Mono 12kHz 30% mod. Pre-em. ON	20 log (‘12k/’1k’)		46/47	-3.0	-1.0	1.0	dB
5	Main distortion	THDm	MONO	12	Mono 1kHz 100% mod. Pre-em. ON		15kLPF	46/47	—	0.1	0.5	%
6	Main overload distortion	THDmmax	MONO	12	Mono 1kHz 200% mod. Pre-em. ON		15kLPF	46/47	—	0.15	0.5	%
7	Main S/N	SNmain	MONO	12	Mono 1kHz, Pre-em. ON	20 log (‘100%/’0%’)	15kLPF	46/47	61	69	—	dB
8	Sub output level	Vsub	ST	12	SUB (L-R) 1kHz, 100% mod., NR OFF			22	150	190	230	mVrms
9	Sub LPF frequency characteristic	FCsub	ST	12	SUB (L-R) 12kHz, 30% mod., NR OFF	20 log (‘12k/’1k’)		22	-3.0	-0.5	1.0	dB
10	Sub distortion	THDsub	ST	12	SUB (L-R) 1kHz, 100% mod., NR OFF		15kLPF	22	—	0.1	1.0	%
11	Sub overload distortion	THDsmax	ST	12	SUB (L-R) 1kHz, 200% mod., NR OFF		15kLPF	22	—	0.2	2.0	%
12	Sub S/N	SNsub	ST	12	SUB (L-R) 1kHz, NR OFF	20 log (‘100%/’0%’)	15kLPF	22	56	64	—	dB
13	Cross talk Stereo → SAP	CTst	SAP	12	ST-L (R) 1kHz, 100% mod., NR ON, SAP Carrier (5fh)	20 log (‘NRSW = 0/ ’NRSW = 1’)	1kBPf	47	60	70	—	dB
14	Cross talk SAP → Stereo	CTsap	ST	12	SAP 1kHz 100% mod. NR ON, Pilot (fh)	20 log (‘NRSW = 1/’NRSW = 0’)	1kBPf	47	60	70	—	dB

No.	Item	Symbol	Mode	Input pin	Input signal	Measurement conditions	Filter	Output pin	Min.	Typ.	Max.	Unit
15	Stereo ON level	THst	ST	12	Change PILOT (fH) Level	0dB = 49mVrms		BUS RETURN	-9.0	-6.0	-3.0	dB
16	Stereo ON/OFF hysteresis	HYst				20 log ('on level'/'off level')						
17	SAP output level	Vsap	SAP	12	SAP 1kHz 100% mod. NR OFF			25	130	160	190	mVrms
18	SAP LPF frequency characteristic	FCsap	SAP	12	SAP 10kHz 30% mod. NR OFF	20 log ('10k'/'1k')		25	-3.0	0	2.5	dB
19	SAP distortion	THDsap	SAP	12	SAP 1kHz 100% mod. NR OFF		15kLPF	25	—	2.5	6.0	%
20	SAP S/N	SNSap	SAP	12	SAP 1kHz, NR OFF	20 log ('100%'/'0%')	15kLPF	25	46	55	—	dB
21	SAP ON level	CTsap	SAP	12	Change SAP Carrier (5fH) Level	0dB = 147mVrms		BUS RETURN	-12.0	-9.0	-6.5	dB
22	SAP ON/OFF hysteresis	THsap				20 log ('on level'/'off level')						
23	ST separation 1 L → R	HYsap	ST	12	ST-L 300Hz 30% mod. NR ON		15kLPF	46/47	23	35	—	dB
24	ST separation 1 R → L	STLsep1	ST	12	ST-R 300Hz 30% mod. NR ON		15kLPF	46/47	23	35	—	dB
25	ST separation 2 L → R	STRsep1	ST	12	ST-L 3kHz 30% mod. NR ON		15kLPF	46/47	23	35	—	dB
26	ST separation 2 R → L	STLsep2	ST	12	ST-R 3kHz 30% mod. NR ON		15kLPF	46/47	23	35	—	dB
27	LSOUT output level	Vtv	EXT	39/40	Sine wave 1kHz, 490mVrms	EXT1 = '1'		46/47	440	490	540	mVrms
28	LSOUT mute attenuation	MUls	EXT	39/40	Sine wave 1kHz, 490mVrms	EXT1 = '1' M1 = '0'	1kBPf	46/47	—	-90	-80	dB
29	LSOUT distortion	THDls	EXT	39/40	Sine wave 1kHz, 490mVrms	EXT1 = '1'	15kLPF	46/47	—	0.01	0.3	%
30	LSOUT overload distortion	THDlsmax	EXT	39/40	Sine wave 1kHz, 2Vrms	EXT1 = '1'	15kLPF	46/47	—	0.03	0.3	%
31	LSOUT S/N	SNls	EXT	39/40	Sine wave 1kHz, 490mVrms	EXT1 = '1'	15kLPF	46/47	80	88	—	dB
32	LSOUT volume maximum attenuation	VOLmin	EXT	39/40	Sine wave 1kHz, 490mVrms	EXT1 = '1' VOL-L = '0' VOL-R = '0'	1kBPf	46/47	—	-90	-80	dB





**Register Specifications**

**Slave address**

SLAVE RECEIVER	SLAVE TRANSMITTER
84H (1000 0100)	85H (1000 0101)

**Register table**

SUB ADDRESS		DATA							
MSB	LSB	BIT7	BIT6	BIT5	BIT4	BIT3	BIT2	BIT1	BIT0
****0000		*		TEST-DA	TEST1	ATT			
****0001		*		SPECTRAL					
****0010		*		WIDEBAND					
****0011		*		EXT1	*	NRSW	FOMO	SAPC	M1
****0100		*		VOL-L					
****0101		*		VOL-R					

\* : Don't Care

**Status Registers**

STA1	STA2	STA3	STA4	STA5	STA6	STA7	STA8
BIT7	BIT6	BIT5	BIT4	BIT3	BIT2	BIT1	BIT0
POWER ON RESET	STEREO	SAP	NOISE	—	—	—	—

**Note)** The microcomputer reads both SAP and NOISE status and judges SAP discrimination.

## Description of Registers

### Control registers

Register	Number of bits	Classification*1	Standard setting	Contents
ATT	4	A	9	Input level adjustment
SPECTRAL	6	A	1F	Adjustment of stereo separation (3kHz)
WIDEBAND	6	A	1F	Adjustment of stereo separation (300Hz)
TEST-DA	1	T	0	DAC test mode
TEST1	1	T	0	Test mode
EXT1	1	U	0	Selection of TV mode or external input mode.
NRSW	1	U	0	Selection of the output signal (Stereo mode, SAP mode)
FOMO	1	U	0	Forced MONO (Left channel only is MONO during SAP output.)
M1	1	U	1	Selection of LSOUT mute function ON/OFF (0: mute ON, 1: mute OFF)
SAPC	1	S	0	Selection of SAP mode or L + R mode according to the presence of SAP broadcasting
VOL-L	1	U	3F	Left channel volume control
VOL-R	1	U	3F	Right channel volume control

\*1 Classification U: User control  
 A: Adjustment  
 S: Proper to set  
 T: Test

### Status registers

Register	Number of bits	Contents
PONRES	1	POWER ON RESET detection; 1: RESET
STEREO	1	Stereo discrimination of the COMPIN input signal; 1: Stereo
SAP	1	SAP discrimination of the COMPIN input signal; 1: SAP
NOISE	1	Noise level discrimination of the SAP signal; 1: Noise

**Description of Control Registers**

ATT (4): Perform input level adjustment.

0 = Level min.

F = Level max.

SPECTRAL (6): Perform high frequency (fs = 3kHz) separation adjustment.

0 = Level max.

3F = Level min.

WIDEBAND (6): Perform low frequency (fs = 300Hz) separation adjustment.

0 = Level min.

3F = Level max.

TEST-DA (1): Set DAC output test mode.

0 = Normal mode

1 = DAC output test mode

In addition, the following output are present at Pin 47.

LSOUT-L (Pin 47): DA control DC level

TEST1 (1): Monitor SAP BPF and NR BPF output.

0 = Normal mode

1 = SAP BPF and NR BPF output

In addition, the following outputs are present at Pins 47 and 46.

LSOUT-L (Pin 47): SAP BPF OUT

LSOUT-R (Pin 46): NR BPF OUT

EXT (1): Select TV mode or external input mode

0 = TV mode

1 = External input mode

NRSW (1): Select stereo mode or SAP mode

0 = Stereo mode

1 = SAP mode

FOMO (1): Select forced MONO mode

0 = Normal mode

1 = Forced MONO mode

M1 (1): Mute the LSOUT-L and LSOUT-R output.

0 = Mute ON

1 = Mute OFF

SAPC (1): Select the SAP signal output mode

When there is no SAP signal, the conditions for selecting SAP output are selected by SAPC.

0 = L + R output is selected

1 = SAP output is selected



VOL-L (6): LSOUT-L output signal level control  
0 = Volume min.  
3F = Volume max.  
-1.25dB/STEP

VOL-R (6): LSOUT-R output signal level control  
0 = Volume min.  
3F = Volume max.  
-1.25dB/STEP

**Description of Mode Control**

Mode control	SAPC = 0	SAPC = 1
NRSW	<p>“Select dbx input and TV decoder output”                      Conditions: FOMO = 0                      NRSW = 0 (MONO or ST output)</p> <ul style="list-style-type: none"> <li>• During ST input: left channel: L, right channel: R</li> <li>• During other input: left channel: L + R, right channel: L + R</li> </ul> <p>NRSW = 1 (SAP output)</p> <ul style="list-style-type: none"> <li>• When there is “SAP” during SAP discrimination                      – left channel: SAP, right channel: SAP</li> <li>• When there is “No SAP”, output is the same as when NRSW = 0.</li> </ul>	<p>“Select dbx input and TV decoder output”                      Conditions: FOMO = 0                      NRSW = 0 (MONO or ST output)</p> <p>As on the left</p> <p>NRSW = 1 (SAP output)</p> <ul style="list-style-type: none"> <li>• Regardless of the presence of SAP discrimination, dbx input: “SAP”                      left channel: SAP, right channel: SAP                      However, when there is no SAP, SAPOUT output is soft muted (–7dB)</li> </ul>
FOMO	“Forced MONO”	
	<p>FOMO = 1</p> <ul style="list-style-type: none"> <li>• During SAP output: left channel: L + R, right channel: SAP</li> <li>• During ST or MONO output: left channel: L + R, right channel: L + R</li> </ul>	
SAPC	<p>Change the selection conditions for “MONO or ST output” and “SAP output”.</p> <p>SAPC = 0: Switch to SAP output when there is SAP discrimination.                      Do not switch to SAP output when there is no SAP discrimination.</p> <p>SAPC = 1: Switch to SAP output regardless of whether there is SAP discrimination.</p>	
M1	“MUTE”	
	<p>M1 = 0: LSOUT-L, R output is muted.</p>	

Decoder Output and Mode Control Table 1 (SAPC = 1)

Input signal mode	Mode detection			Mode control			dbx input	Output	
	ST	SAP	NOISE	NRSW	FOMO	SAPC		Lch	Rch
MONO*1	0	0	0	0	*	1	MUTE	L + R	L + R
	0	0	0	1	0	1	SAP	SAP	SAP
	0	0	0	1	1	1	SAP	L + R	SAP
	0	*	1	0	*	1	MUTE	L + R	L + R
	0	*	1	1	0	1	(SAP)	(SAP)	(SAP)
	0	*	1	1	1	1	(SAP)	L + R	(SAP)
STEREO*1	1	0	*	0	0	1	L - R	L	R
	1	0	*	0	1	1	MUTE	L + R	L + R
	1	1	1	0	0	1	L - R	L	R
	1	1	1	0	1	1	MUTE	L + R	L + R
	1	0	0	1	0	1	SAP	SAP	SAP
	1	0	0	1	1	1	SAP	L + R	SAP
	1	*	1	1	0	1	(SAP)	(SAP)	(SAP)
1	*	1	1	1	1	(SAP)	L + R	(SAP)	
MONO & SAP	0	1	*	0	0	1	MUTE	L + R	L + R
	0	1	*	0	1	1	MUTE	L + R	L + R
	0	1	0	1	0	1	SAP	SAP	SAP
	0	1	0	1	1	1	SAP	L + R	SAP
	0	1	1	1	0	1	(SAP)	(SAP)	(SAP)
	0	1	1	1	1	1	(SAP)	L + R	(SAP)
STEREO & SAP	1	1	*	0	0	1	L - R	L	R
	1	1	*	0	1	1	MUTE	L + R	L + R
	1	1	0	1	0	1	SAP	SAP	SAP
	1	1	0	1	1	1	SAP	L + R	SAP
	1	1	1	1	0	1	(SAP)	(SAP)	(SAP)
	1	1	1	1	1	1	(SAP)	L + R	(SAP)

**Note**

(SAP) : The SAPOUT output signal is soft muted (approximately -7dB).

The signal is soft muted when NOISE = 1.

\* : Don't care.

\*1 SAP or NOISE discrimination may be made during MONO or STEREO input when the noise is inputted in the weak electric field.

Then microcomputer reads "NOISE" status from IC and decides whether SAP is outputted.

"NOISE" status rises earlier than "SAP" status when the amount of noise is increased to COMPIN.

Decoder Output and Mode Control Table 2 (SAPC = 0)

Input signal mode	Mode detection			Mode control			dbx input	Output	
	ST	SAP	NOISE	NRSW	FOMO	SAPC		Lch	Rch
MONO *1	0	0	*	*	*	0	MUTE	L + R	L + R
	0	1	1	0	0	0	MUTE	L + R	L + R
	0	1	1	0	1	0	MUTE	L + R	L + R
	0	1	1	1	0	0	(SAP)	(SAP)	(SAP)
	0	1	1	1	1	0	(SAP)	L + R	(SAP)
STEREO *1	1	0	*	0	0	0	L - R	L	R
	1	0	*	0	1	0	MUTE	L + R	L + R
	1	0	*	1	0	0	L - R	L	R
	1	0	*	1	1	0	MUTE	L + R	L + R
	1	1	1	0	0	0	L - R	L	R
	1	1	1	0	1	0	MUTE	L + R	L + R
	1	1	1	1	0	0	(SAP)	(SAP)	(SAP)
MONO & SAP	0	1	0	0	0	0	MUTE	L + R	L + R
	0	1	0	0	1	0	MUTE	L + R	L + R
	0	1	0	1	0	0	SAP	SAP	SAP
	0	1	0	1	1	0	SAP	L + R	SAP
	0	1	1	0	0	0	MUTE	L + R	L + R
	0	1	1	0	1	0	MUTE	L + R	L + R
	0	1	1	1	0	0	(SAP)	(SAP)	(SAP)
	0	1	1	1	1	0	(SAP)	L + R	(SAP)
STEREO & SAP	1	1	0	0	0	0	L - R	L	R
	1	1	0	0	1	0	MUTE	L + R	L + R
	1	1	0	1	0	0	SAP	SAP	SAP
	1	1	0	1	1	0	SAP	L + R	SAP
	1	1	1	0	0	0	L - R	L	R
	1	1	1	0	1	0	MUTE	L + R	L + R
	1	1	1	1	0	0	(SAP)	(SAP)	(SAP)
	1	1	1	1	1	0	(SAP)	L + R	(SAP)

**Note**

(SAP) : The SAPOUT output signal is soft muted (approximately -7dB).

The signal is soft muted when NOISE = 1.

\* : Don't care.

\*1 SAP or NOISE discrimination may be made during MONO or STEREO input when the noise is inputted in the weak electric field.

Then microcomputer reads "NOISE" status from IC and decides whether SAP is outputted.

"NOISE" status rises earlier than "SAP" status when the amount of noise is increased to COMPIN.

**Description of Operation**

The US audio multiplexing system possesses the base band spectrum shown in Fig. 1.

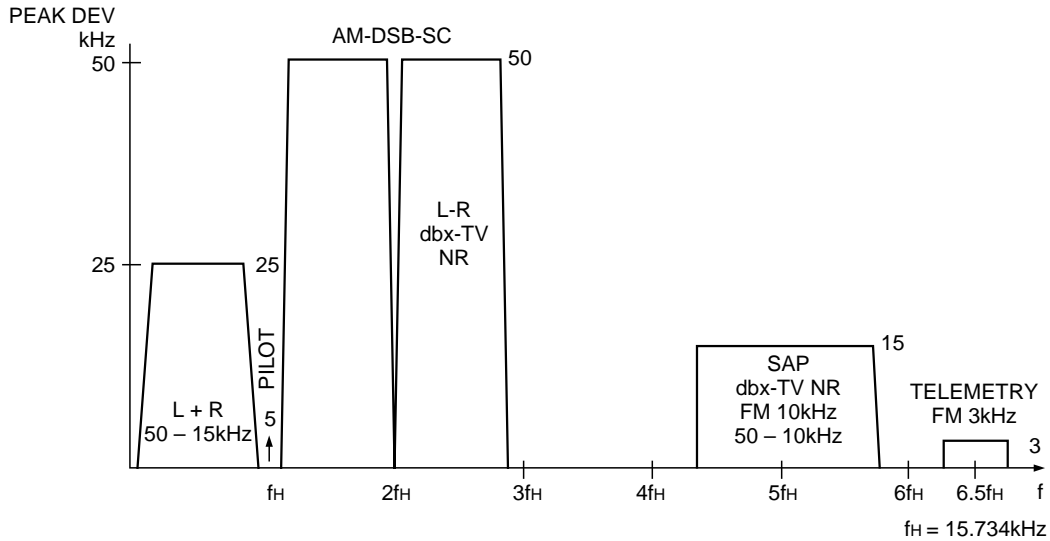

**Fig. 1. Base band spectrum**

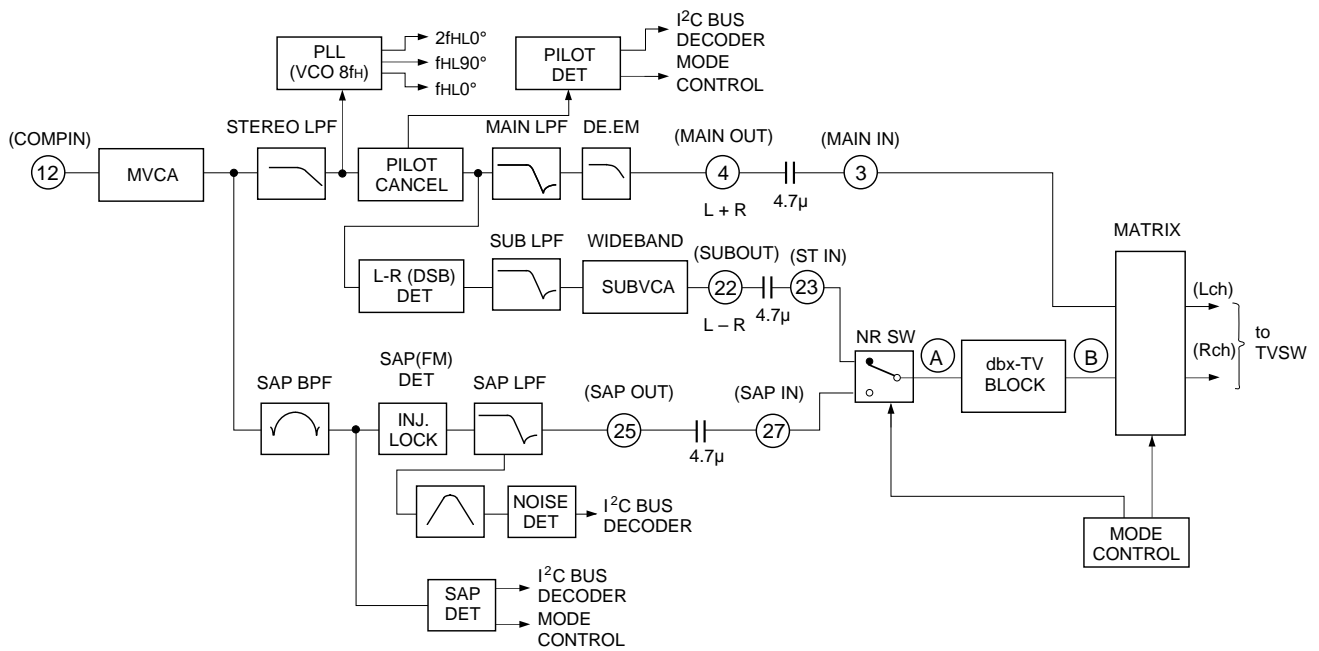

**Fig. 2. Overall block diagram (See Fig. 3 for the dbx-TV block)**

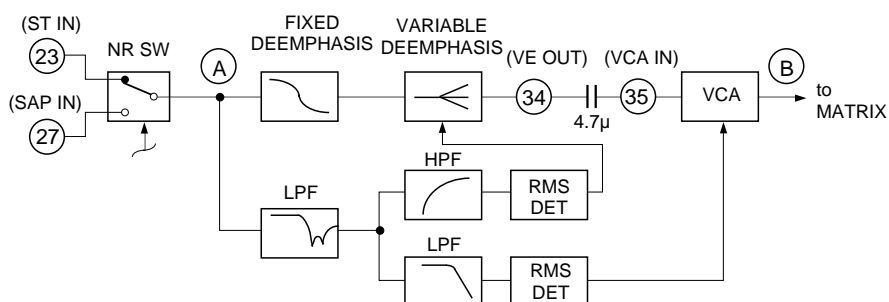

**Fig 3. dbx-TV block**

(1) L + R (MAIN)

After the audio multiplexing signal input from COMPIN (Pin 12) passes through MVCA, the SAP signal and telemetry signal are suppressed by STEREO LPF. Next, the pilot signals are canceled. Finally, the L – R signal and SAP signal are removed by MAIN LPF, and frequency characteristics are flattened (de-emphasized) and input to the matrix.

(2) L – R (SUB)

The L – R signal follows the same course as L + R before the pilot signal is canceled. L – R has no carrier signal, as it is a suppressed-carrier double-sideband amplitude modulated signal (DSB-AM modulated). For this reason, the pilot signal is used to regenerate the carrier signal (quasi-sine wave) to be used for the demodulation of the L – R signal. In the last stage, the residual high frequency components are removed by SUB LPF and the L – R signal is input to the dbx-TV block via the NRSW circuit after passing through SUBVCA.

(3) SAP

SAP is an FM signal using 5fH as a carrier as shown in the Fig. 1. First, the SAP signal only is extracted using SAP BPF. Then, this is subjected to FM detection. Finally, residual high frequency components are removed and frequency characteristics flattened using SAP LPF, and the SAP signal is input to the dbx-TV block via the NRSW circuit. When there is no SAP signal, the Pin 25 output is soft muted.

(4) Mode discrimination

Stereo discrimination is performed by detecting the pilot signal amplitude. SAP discrimination is performed by detecting the 5fH carrier amplitude. NOISE discrimination is performed by detecting the noise near 25kHz after FM detection of SAP signal.

(5) dbx-TV block

Either the L – R signal or SAP signal input respectively from ST IN (Pin 23) or SAP IN (Pin 27) is selected by the mode control and input to the dbx-TV block.

The input signal then passes through the fixed de-emphasis circuit and is applied to the variable de-emphasis circuit. The signal output from the variable de-emphasis circuit passes through an external capacitor and is applied to VCA (voltage control amplifier). Finally, the VCA output is converted from a current to a voltage using an operational amplifier and then input to the matrix.

The variable de-emphasis circuit transmittance and VCA gain are respectively controlled by Each of effective value detection circuits. Each of the effective value detection circuits passes the input signal through a predetermined filter for weighting before the effective value of the weighted signal is detected to provide the control signal.

(6) Matrix, TVSW

The signals (L + R, L – R, SAP) input to “MATRIX” become the outputs for the ST-L, ST-R, MONO and SAP signals according to the mode control and whether there is ST / SAP discrimination.

“TVSW” switches the “MATRIX” output signal and external input signal.

(7) Others

“MVCA” is a VCA which adjusts the input signal level to the standard level of this IC.

“Bias” supplies the reference voltage and reference current to the other blocks. The current flowing to the resistor connecting IREF (Pin 15) with GND become the reference current.

Application Circuit

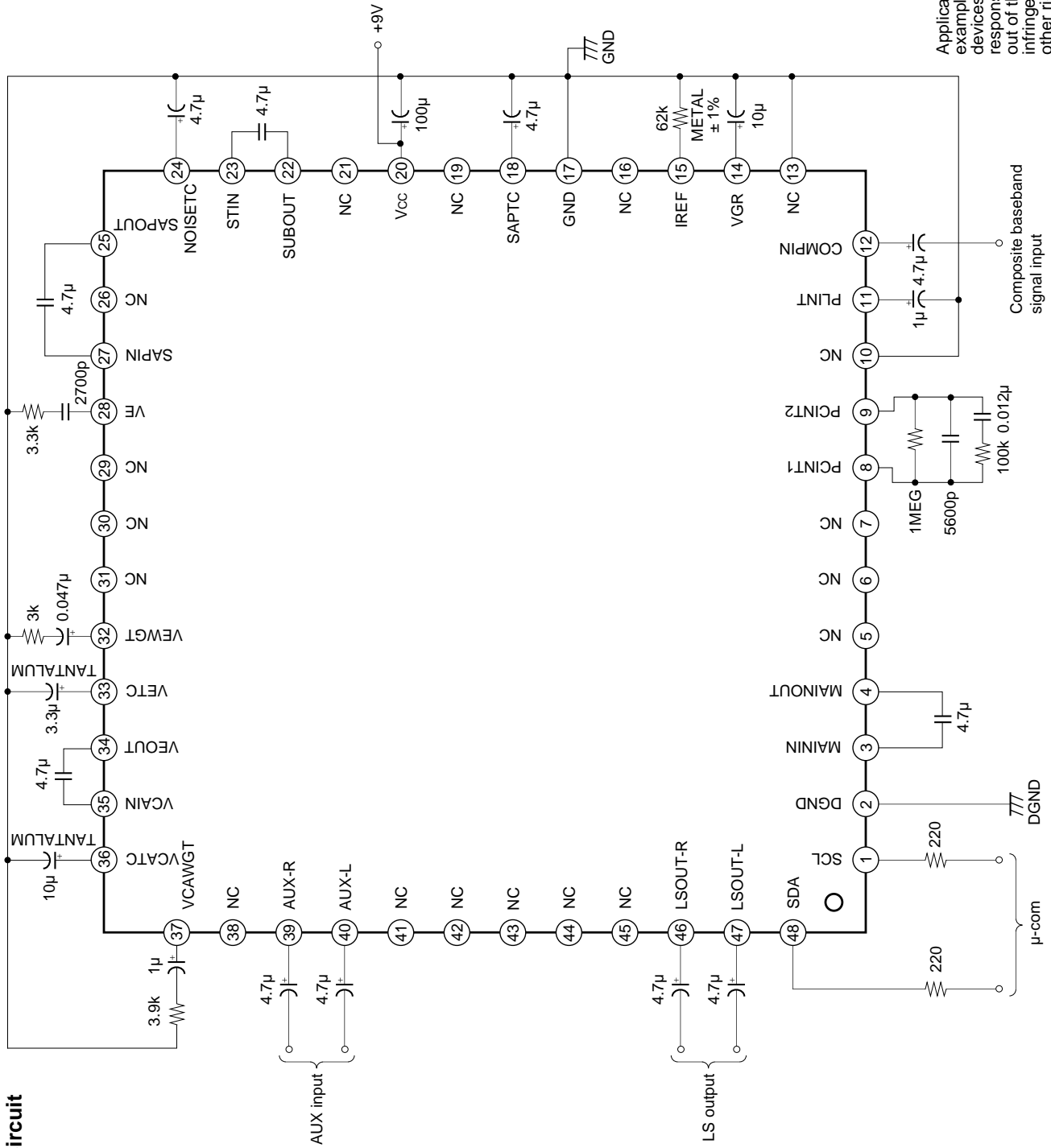

Application circuits shown are typical examples illustrating the operation of the devices. Sony cannot assume responsibility for any problems arising out of the use of these circuits or for any infringement of third party patent and other right due to same.

**I<sup>2</sup>C BUS block items (SDA, SCL)**

No.	Item	Symbol	Min.	Typ.	Max.	Unit
1	High level input voltage	V <sub>IH</sub>	3.0	—	5.0	V
2	Low level input voltage	V <sub>IL</sub>	0	—	1.5	
3	High level input current	I <sub>IH</sub>	—	—	10	μA
4	Low level input current	I <sub>IL</sub>	—	—	10	
5	Low level output voltage SDA (Pin 48) during 3mA inflow	V <sub>OL</sub>	0	—	0.4	V
6	Maximum inflow current	I <sub>OL</sub>	3	—	—	mA
7	Input capacitance	C <sub>i</sub>	—	—	10	pF
8	Maximum clock frequency	f <sub>SCL</sub>	0	—	100	kHz
9	Minimum waiting time for data change	t <sub>BUF</sub>	4.7	—	—	μs
10	Minimum waiting time for start of data transfer	t <sub>HD: STA</sub>	4.0	—	—	
11	Low level clock pulse width	t <sub>LOW</sub>	4.7	—	—	
12	High level clock pulse width	t <sub>HIGH</sub>	4.0	—	—	
13	Minimum waiting time for start preparation	t <sub>SU: STA</sub>	4.7	—	—	
14	Minimum data hold time	t <sub>HD: DAT</sub>	0	—	—	
15	Minimum data preparation time	t <sub>SU: DAT</sub>	250	—	—	ns
16	Rise time	t <sub>R</sub>	—	—	1	μs
17	Fall time	t <sub>F</sub>	—	—	300	ns
18	Minimum waiting time for stop preparation	t <sub>SU: STO</sub>	4.7	—	—	μs

I<sup>2</sup>C BUS load conditions: Pull-up resistor 4kΩ (Connect to +5V)  
Load capacity 200pF (Connect to GND)



**I<sup>2</sup>C BUS Control Signal**

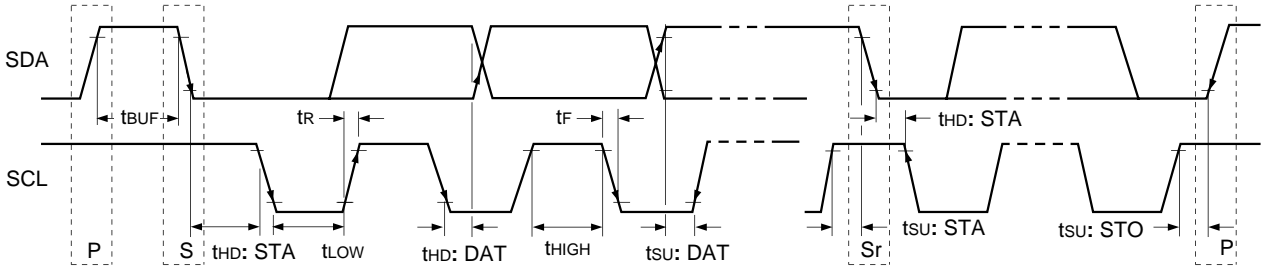

**I<sup>2</sup>C BUS Signal**

There are two I<sup>2</sup>C signals, SDA (Serial DATA) and SCL (Serial CLOCK) signals. SDA is a bidirectional signal.

- Accordingly there are 3 values outputs, H, L and HIZ.

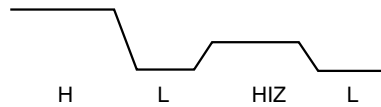

- I<sup>2</sup>C transfer begins with Start Condition and ends with Stop Condition.

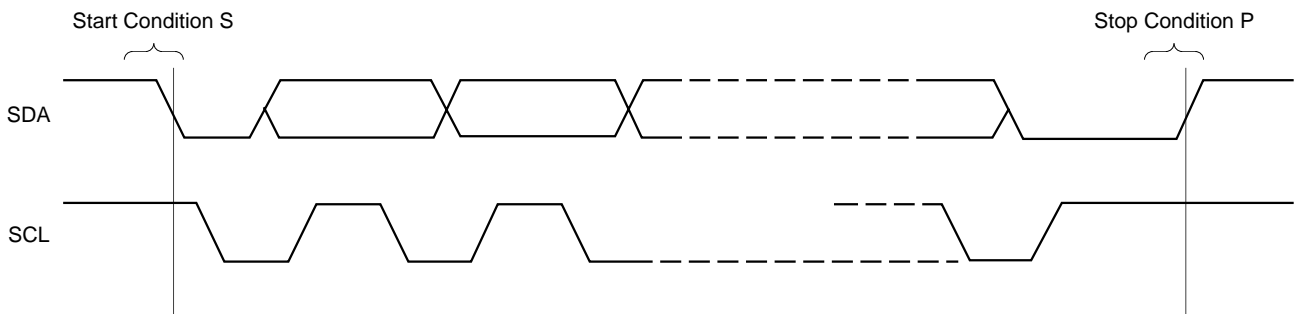

• I<sup>2</sup>C data Write (Write from I<sup>2</sup>C controller to the IC)

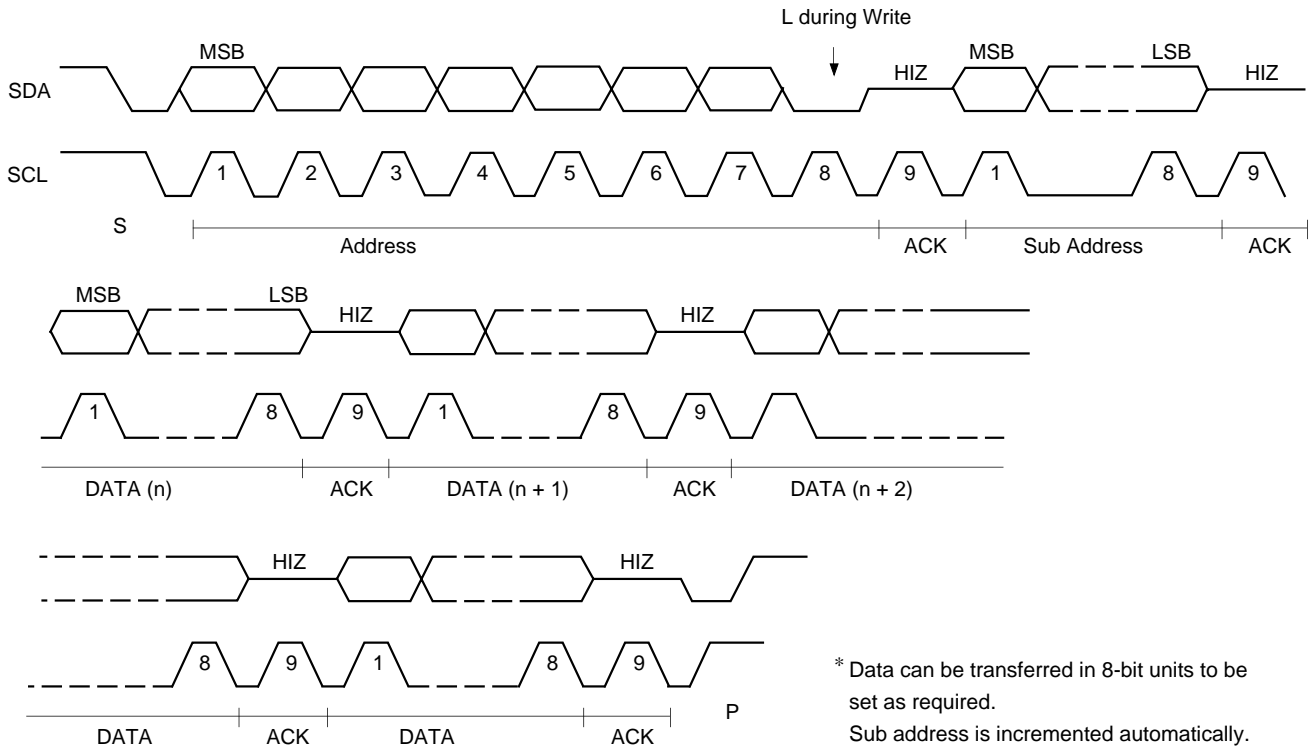

• I<sup>2</sup>C data Read (Read from the IC to I<sup>2</sup>C controller)

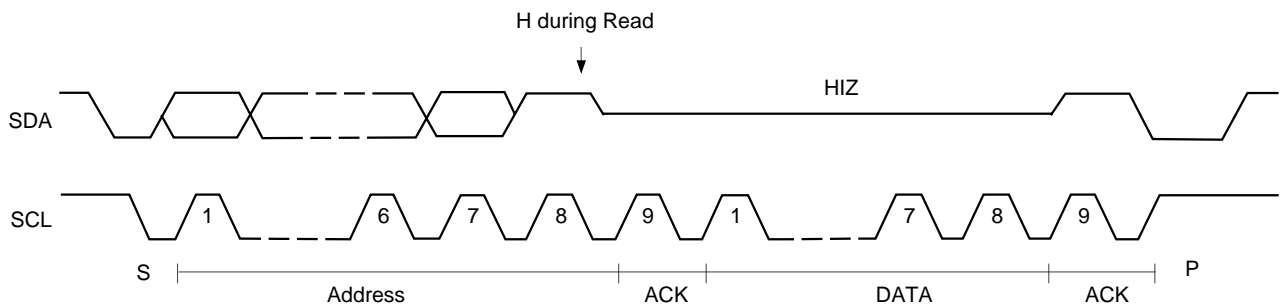

• Read timing

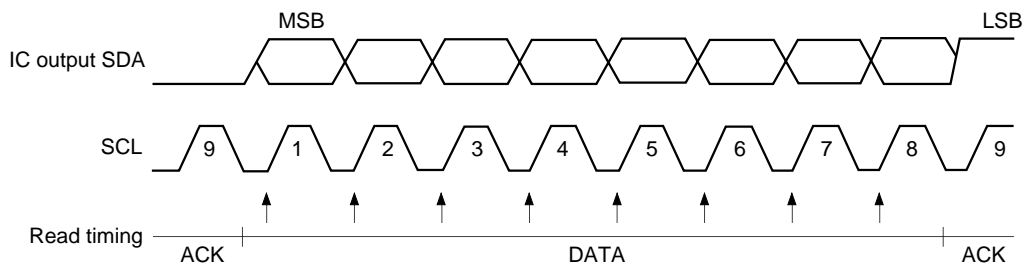

\* Data Read is performed during SCL rise.

**Input level vs. Distortion characteristics 1 (MONO)**

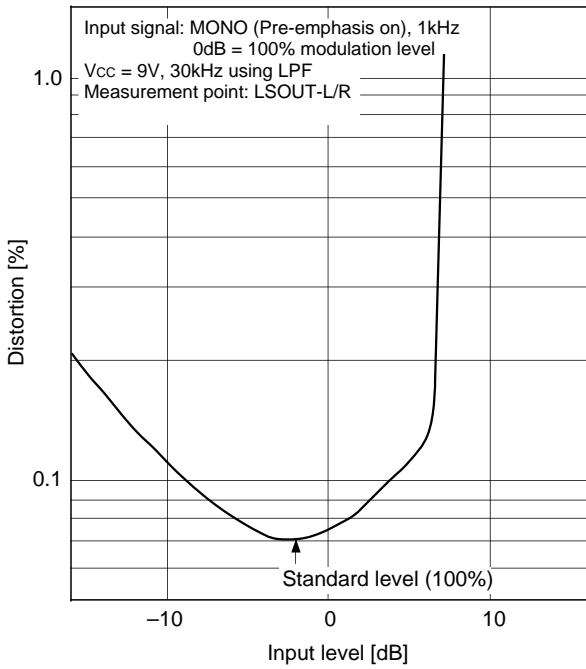

**Input level vs. Distortion characteristics 2 (Stereo)**

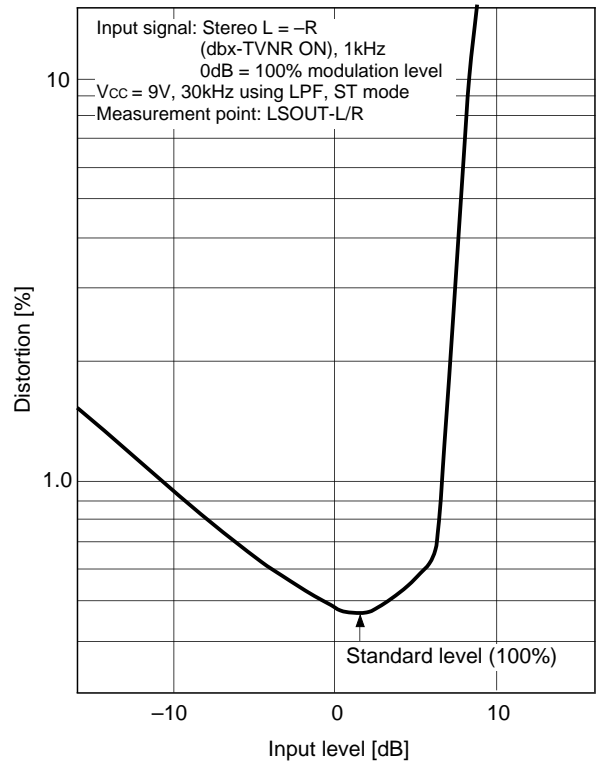

**Input level vs. Distortion characteristics 3 (SAP)**

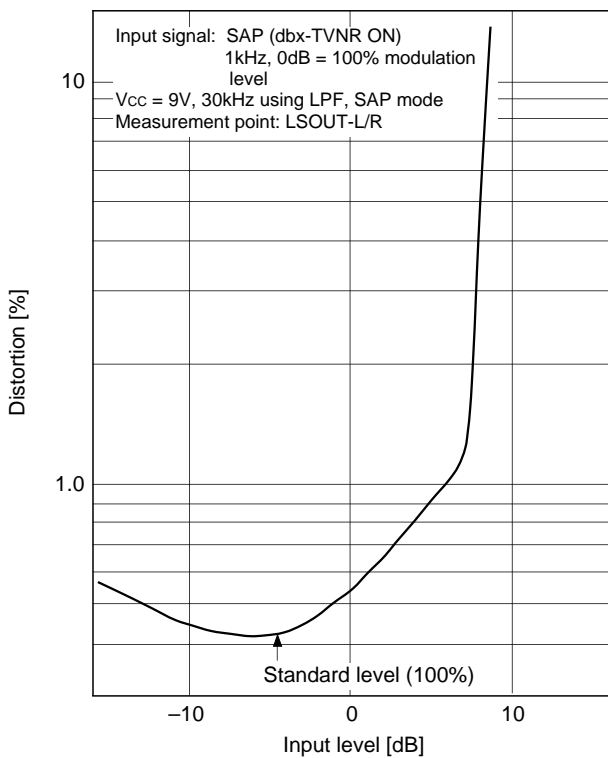

**Stereo LPF frequency characteristics**

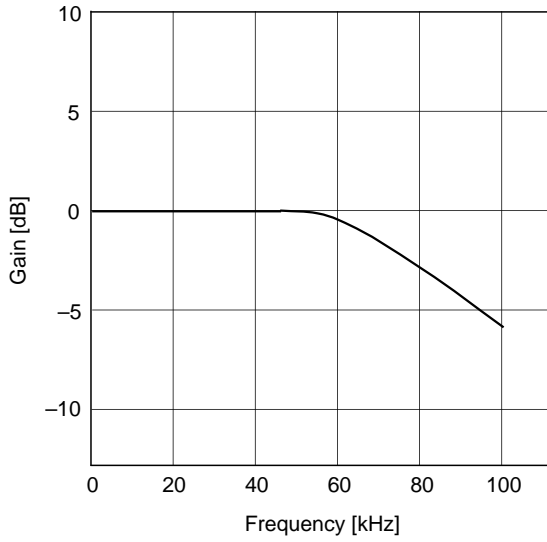

**Main LPF and Sub LPF frequency characteristics**

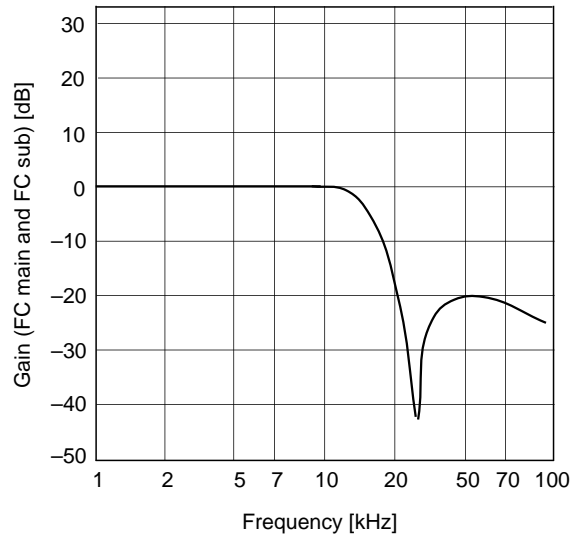

**SAP frequency characteristics and group delay**

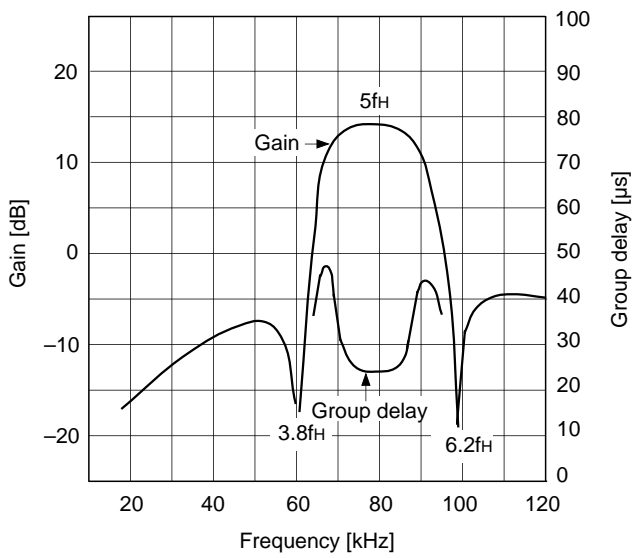

**Volume characteristics**

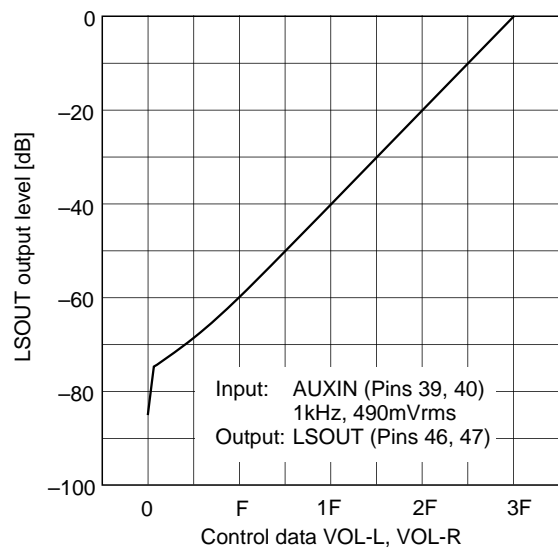

Package Outline Unit: mm

48PIN QFP (PLASTIC)

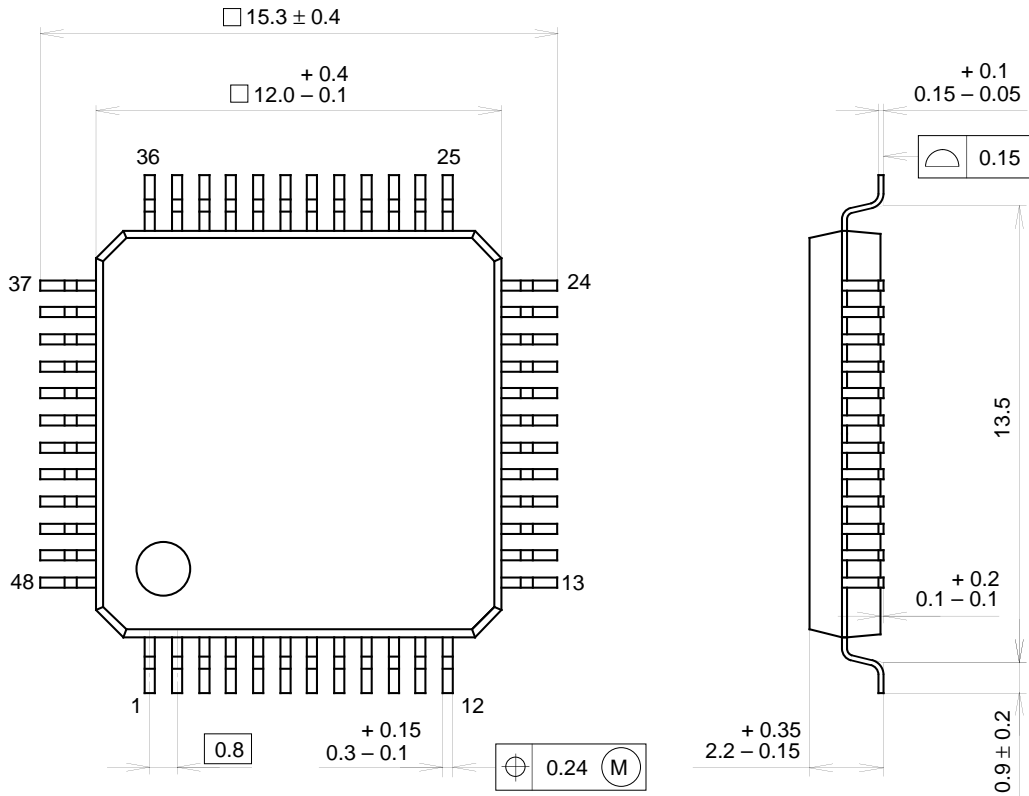

PACKAGE STRUCTURE

SONY CODE	QFP-48P-L04
EIAJ CODE	QFP048-P-1212
JEDEC CODE	_____

PACKAGE MATERIAL	EPOXY RESIN
LEAD TREATMENT	PALLADIUM PLATING
LEAD MATERIAL	COPPER ALLOY
PACKAGE MASS	0.7g