

SONY

CXA2500M/N

Dual REC/PB Preamplifier

Description

The CXA2500M/N is a dual recording/playback preamplifier system bipolar IC which has been developed for the low voltage operating cassette tape recorder.

Features

- Low quiescent current ($V_{CC} = 2V$)
PB: $I_{CC} = 3.2mA$ (typ.)
REC: $I_{CC} = 5.2mA$ (typ.)
- Very few external parts
- Built-in Metal/Normal selection switch
- Small switching noise due to internal transient muting

Applications

3V headphone radio cassette recorders

Structure

Bipolar silicon monolithic IC

Block Diagram

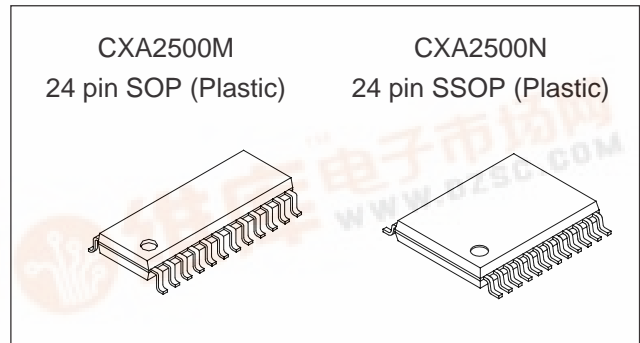
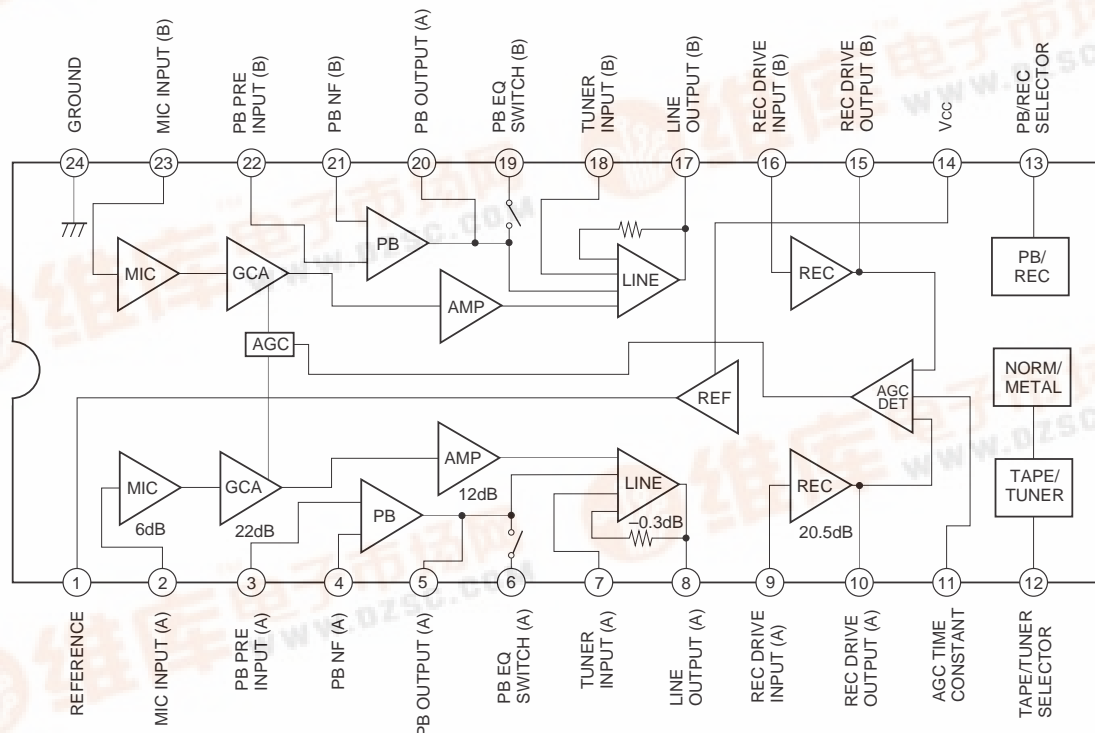

Absolute Maximum Ratings ($T_a = 25^\circ C$)

• Supply voltage	V_{CC}	7	V
• Operating temperature	T_{opr}	-20 to +75	$^\circ C$
• Storage temperature	T_{stg}	-65 to +150	$^\circ C$
• Allowable power dissipation	P_D		
	CXA2500M	600	mW
	CXA2500N	470	mW

Operating Conditions

Supply voltage	PB	V_{CC}	1.2 to 3.5	V
	REC	V_{CC}	1.6 to 3.5	V

Sony reserves the right to change products and specifications without prior notice. This information does not convey any license by any implication or otherwise under any patents or other right. Application circuits shown, if any, are typical examples illustrating the operation of the devices. Sony cannot assume responsibility for any problems arising out of the use of these circuits.



Pin Description

Pin voltage is during $V_{CC} = 2V$

No.	Symbol	Voltage (Typ.)	Equivalent circuit	Description
2 23	MIC IN (A) MIC IN (B)	0.93V		MIC preamplifier input
3 22	PB PRE IN (A) PB PRE IN (B)	0.93V		PB preamplifier input
4 21	PB-NF (A) PB-NF (B)	0.93V		PB equalizer circuit negative feedback
5 20	PB OUT (A) PB OUT (B)	0.93V		PB preamplifier output
6 19	PB EQ SW (A) PB EQ SW (B)	0.93V		PB equalizer switch

No.	Symbol	Voltage (Typ.)	Equivalent circuit	Description
7 18	TUNER IN (A) TUNER IN (B)	0.93V		Tuner input
8 17	LINE OUT (A) LINE OUT (B)	0.58V		Line amplifier output
9 16	REC AMP IN (A) REC AMP IN (B)	0.93V		REC drive input
10 15	REC AMP OUT (A) REC AMP OUT (B)	1.0V		REC drive output
1	REF	0.93V		Reference voltage output

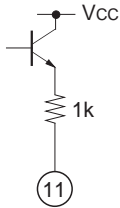
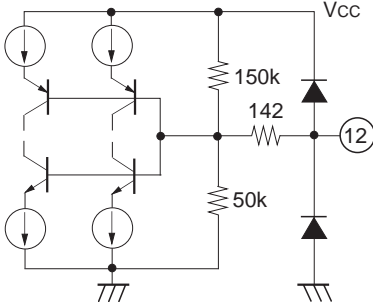
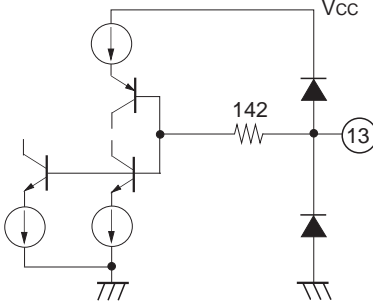
No.	Symbol	Voltage (Typ.)	Equivalent circuit	Description
11	AGC TC	0.37V		AGC time constant
12	TAPE/TUNER	0.5V (Open)		Tape/tuner selection During Tape/Normal: 0V During Tape/Metal: 0.5V During Tuner Mode: 2.0V
13	PB/REC	0V (2.0V)		PB/REC selection During PB = 0V During REC = 2.0V

V_{CC} = 2.0V, f = 1kHz, T_a = 25°C, unless otherwise specified.

Electrical Characteristics

Item	Symbol	SW condition																Input condition			Measurement conditions	Min.	Typ.	Max.	Unit
		S1	S2	S3	S4	S5	S6	S7	S8	S9	S10	S11	S12	S13	Vin1	Vin2	Vin3	Unit							
Tape playback quiescent current	Icq1	A	OFF	PB	C	OFF	A	OFF	B	B	B	B	A							V _{CC} = 2.0V No signal, Tape	1.8	3.2	5.5		
MIC recording quiescent current	Icq2	A	OFF	REC	C	OFF	A	OFF	B	B	B	B	A							V _{CC} = 2.0V No signal, Mic Rec	3.8	5.2	7.2	mA	
Radio playback quiescent current	Icq3	A	OFF	PB	A	OFF	A	OFF	B	B	B	B	A							V _{CC} = 2.0V No signal, Tuner	1.3	2.8	4.7		
Radio peccording quiescent current	Icq4	A	OFF	REC	A	OFF	A	OFF	B	B	B	B	A							V _{CC} = 2.0V No signal, Tuner Rec	2.8	4.2	6.2		
Reference voltage	Vref	A	ON	PB	C	OFF	A	OFF	B	B	B	B	A							V _{CC} = 2.0V No signal, Tape	0.78	0.93	1.05	V	
(1) PLAYBACK MODE																									
Open loop voltage gain	Gvo	A	ON	PB	C	OFF	A	ON	A	A	B	B	A							V _O = -15dBm	54	65	—		
Close loop voltage gain 1	Gvc1	A	ON	PB	C	OFF	A	ON	B	B	B	B	A							V _O = -15dBm	28.5	30.8	33.0	dB	
Close loop voltage gain 2	Gvc2	A	ON	PB	B	OFF	A	ON	B	B	B	B	A							V _O = -15dBm	25.5	27.2	29.0		
Channel balance	CB	A	ON	PB	C	OFF	A	ON	B	B	B	B	A							V _O = -15dBm	-2.0	0	+2.0		
Total harmonic distortion	THD	A	ON	PB	C	OFF	A	ON	B	B	B	B	A							V _O = -15dBm	—	0.3	1.05	%	
Maximum output voltage	Vom	A	ON	PB	C	OFF	A	ON	B	B	B	B	A							THD = 1%	190	300	—	mV	
Output noise voltage	Vno	A	ON	PB	C	OFF	A	OFF	B	B	B	B	A							R _g = 2.2kΩ	—	72	125	μV	
Ripple rejection	RR	B	ON	PB	C	OFF	A	OFF	B	B	B	B	A							f _r = 100Hz V _r = -30dBm	27.5	35	—	dB	

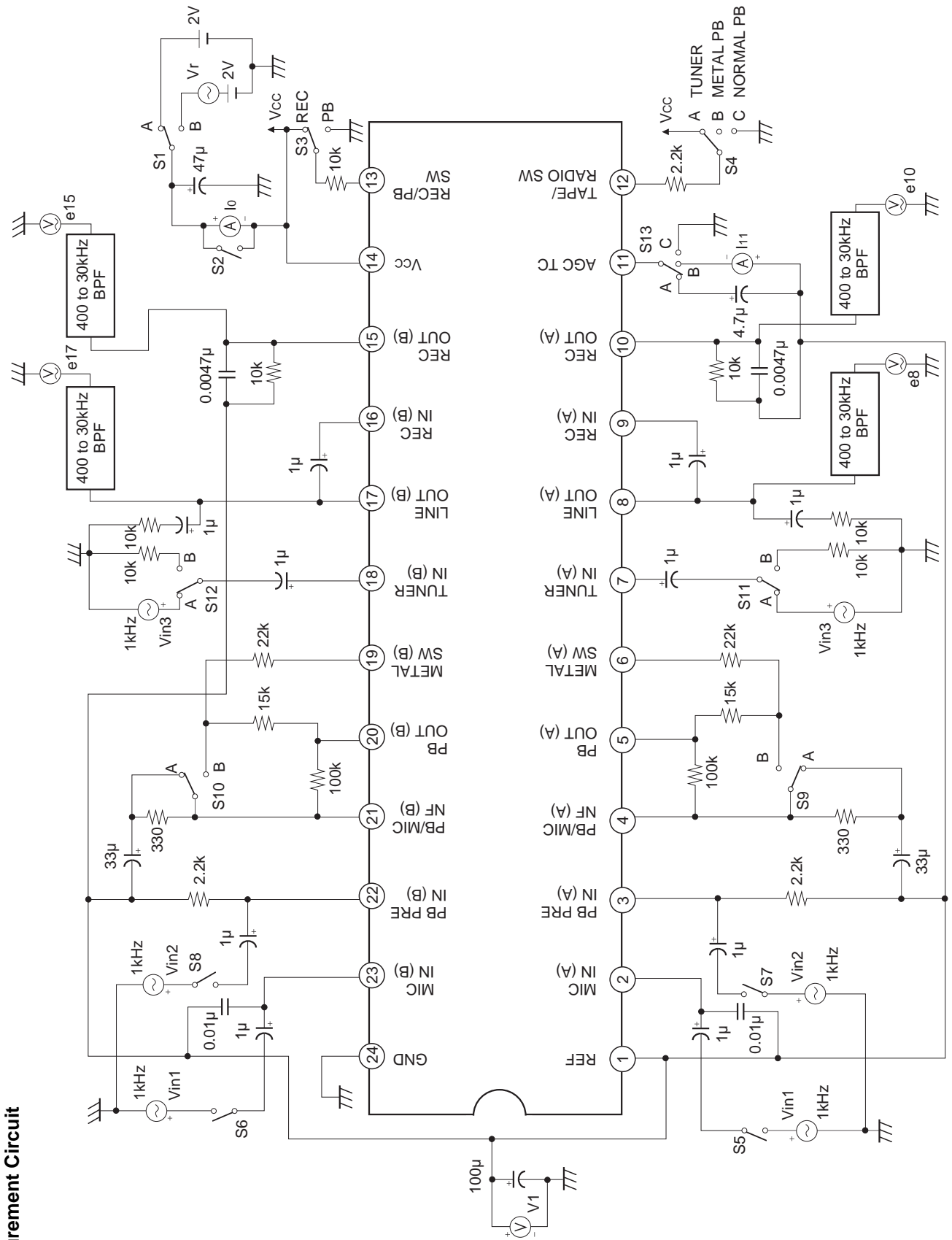

Measurement Circuit

Description of Operation

REF Pin (Pin 1)

A low impedance pin for outputting the internal reference voltage, which is fixed at 0.93V regardless of supply voltage variation.

LINE OUT Pin (Pin 8)

This output pin outputs signal from any selected source (MIC, Tape or Tuner) to the subsequent stages such as Dolby NR or power amplifier for further signal processing. It is internally biased at 0.58V so as to achieve maximum dynamic swing at minimum supply voltage of 1.2V. The change of DC potential at this pin that may result from any changeover of PB/REC or Tape/Tuner switch was set to be minimum, thus reducing any potential occurrence of switching noise.

REC Out Pin (Pin 10)

This recording driver output pin is internally biased at 1.0V to achieve maximum signal swing at minimum supply voltage of 1.6V during the recording mode. The REC OUT will be momentarily muted during the changeover of PB/REC or Tape/Tuner modes, so as to prevent mis-recording of any undesired switching noise. The muting period is determined by the values of R and C at Pins 12 or 13.

AGC TC Pin (Pin 11)

This is the external pin for AGC filter during the MIC Recording mode. The attack time is determined by the 1kΩ resistor inside the IC and the external electrolytic capacitor. The recovery time is determined by both external resistor and electrolytic capacitor at Pin 11.

Notes on Operation

1. The following table shows the potential at Pins 12 and 13 and the associated operating states of the amplifier. Each of the pins, when at the same potential as Pin 14, has H level, and when at the same potential as Pin 24, has L level.

System Control Operation Table

Control pins	Pin 13	L			H	
	Pin 12	L	FLOAT	H	L, FLOAT	H
Amplifier operating state	Operating mode	Playback (Normal)	Playback (Metal)	Tuner Mode	MIC Recording	Tuner Recording
MIC AMP		OFF	OFF	OFF	ON	OFF
AGC DET		OFF	OFF	OFF	ON	OFF
GCA		OFF	OFF	OFF	ON	OFF
AMP		OFF	OFF	OFF	ON	OFF
PB AMP		ON	ON	OFF	OFF	OFF
EQ SWITCH		OFF	ON	OFF	OFF	OFF
LINE AMP		ON	ON	ON	ON	ON
REC AMP		OFF	OFF	OFF	ON	ON

2. PB Mode:

To reduce the PB amplifier DC output offset, it is recommended that 39kΩ resistor be connected as shown in the Application Circuit. However, too low this resistor value may affect the low frequency portion of the PB frequency response. The inter-relationship of the RC values in the playback equalization network is as shown below:

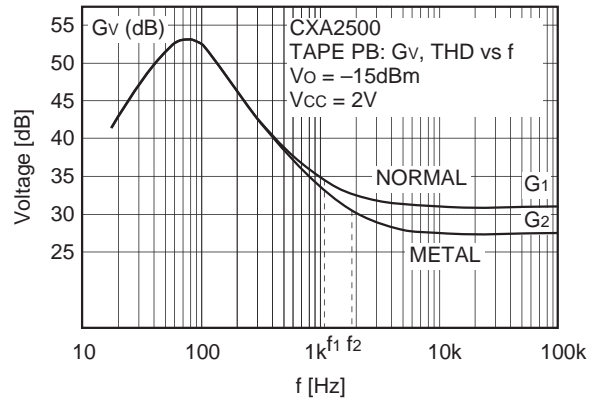
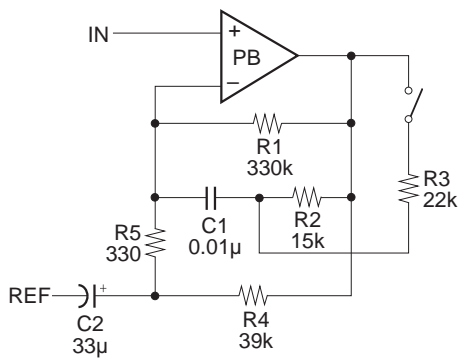

During Normal PB mode,

$$\text{Gain } G1 = 20 \log (R2 + R5)/R5$$

$$\text{3dB cut-off frequency, } f_1 = 1/(2 \times 3.1416 \times C1 \times R2)$$

During Metal PB mode,

$$\text{Gain } G2 = 20 \log (R2//R3 + R5)/R5$$

$$\text{3dB cut-off frequency, } f_2 = 1/(2 \times 3.1416 \times C1 \times R2//R3)$$

3. Use of RC at Tape/Tuner and PB/REC pins:

The purpose of the external RC components at the switch inputs is to create an internal mute pulse so as to mute the REC OUT momentarily during the switching operation. By doing so, the switching click noise that may appear at REC OUT can be reduced. The selection of the RC values affects the duration of the mute pulse. It is recommended to use resistor of 2.2kΩ and below at Tape/Tuner pin, i.e Pin 12. These RC components may be removed if such internal pop noise countermeasure is not required.

Package Outline Unit: mm

CXA2500M

24PIN SOP (PLASTIC)

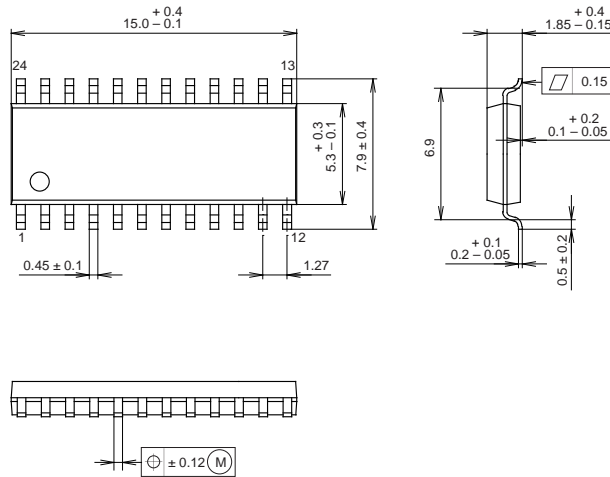

PACKAGE STRUCTURE

SONY CODE	SOP-24P-L01
EIAJ CODE	+SOP024-P-0300-A
JEDEC CODE	—

MOLDING COMPOUND	EPOXY/PHENOL RESIN
LEAD TREATMENT	SOLDER PLATING
LEAD MATERIAL	COPPER ALLOY / 42ALLOY
PACKAGE WEIGHT	0.3g

CXA2500N

24PIN SSOP(PLASTIC)

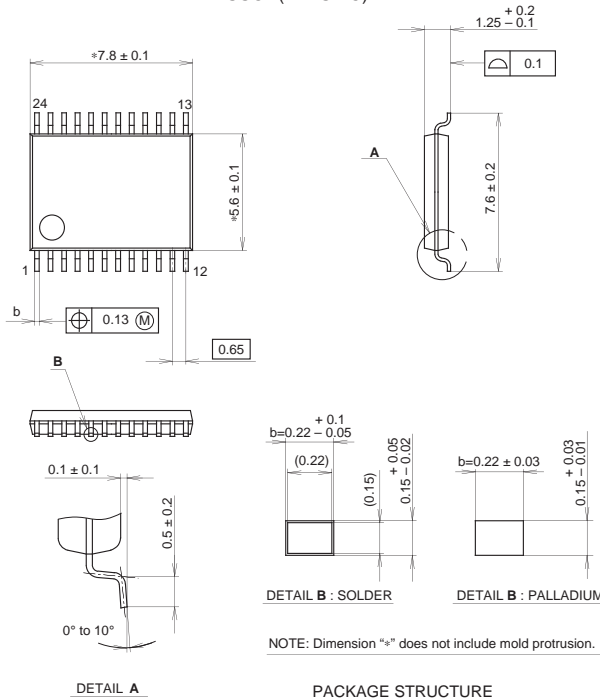

NOTE: Dimension "*e*" does not include mold protrusion.

PACKAGE STRUCTURE

SONY CODE	SSOP-24P-L01
EIAJ CODE	SSOP024-P-0056
JEDEC CODE	—

PACKAGE MATERIAL	EPOXY RESIN
LEAD TREATMENT	SOLDER/PALLADIUM PLATING
LEAD MATERIAL	42/COPPER ALLOY
PACKAGE MASS	0.1g

NOTE : PALLADIUM PLATING

This product uses S-PdPPF (Sony Spec.-Palladium Pre-Plated Lead Frame).