

SONY

CXA2510AQ

Dolby* B Type Noise Reduction System with Playback Equalizer Amplifier

Description

The CXA2510AQ is an IC designed for use in car stereo cassette decks. Functions include Dolby B type noise reduction (NR) system, playback equalizer amplifier and music sensor into a single chip.

Features

- Few external parts
- Small package (40-pin QFP)
- Same pin configuration as for the Dolby B-C type NR system (CXA2511AQ) and no Dolby NR system (CXA2509AQ)
- Dolby B type NR and playback equalizer amplifier into a single chip
- FORWARD/REVERSE head select switch
- Two-system (TAPE/AUX) input select switch
- Music signal interval detection level can be set by the external resistors/capacitors (2 modes).
- High-frequency cut-off of the music sensor circuit can be adjusted by the external capacitance.

Applications

- Car stereo cassette decks
- Playback-only cassette decks

40 pin QFP (Plastic)

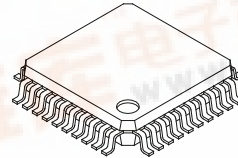

Structure

Bipolar silicon monolithic IC

Absolute Maximum Ratings

• Supply voltage	V _{cc}	12	V
• Operating temperature	T _{opr}	-40 to +85	°C
• Storage temperature	T _{stg}	-65 to +150	°C
• Power dissipation	P _d	430	mW

Operating Condition

Supply voltage	V _{cc}	7.8 to 11	V
----------------	-----------------	-----------	---

* This IC is available only to the licensees of Dolby Laboratories Licensing Corporation from whom licensing and applications information may be obtained.

* "Dolby" and the double D symbols are trademarks of Dolby Laboratories Licensing Corporation.

Sony reserves the right to change products and specifications without prior notice. This information does not convey any license by any implication or otherwise under any patents or other right. Application circuits shown, if any, are typical examples illustrating the operation of the devices. Sony cannot assume responsibility for any problems arising out of the use of these circuits.

Block Diagram and Pin Configuration

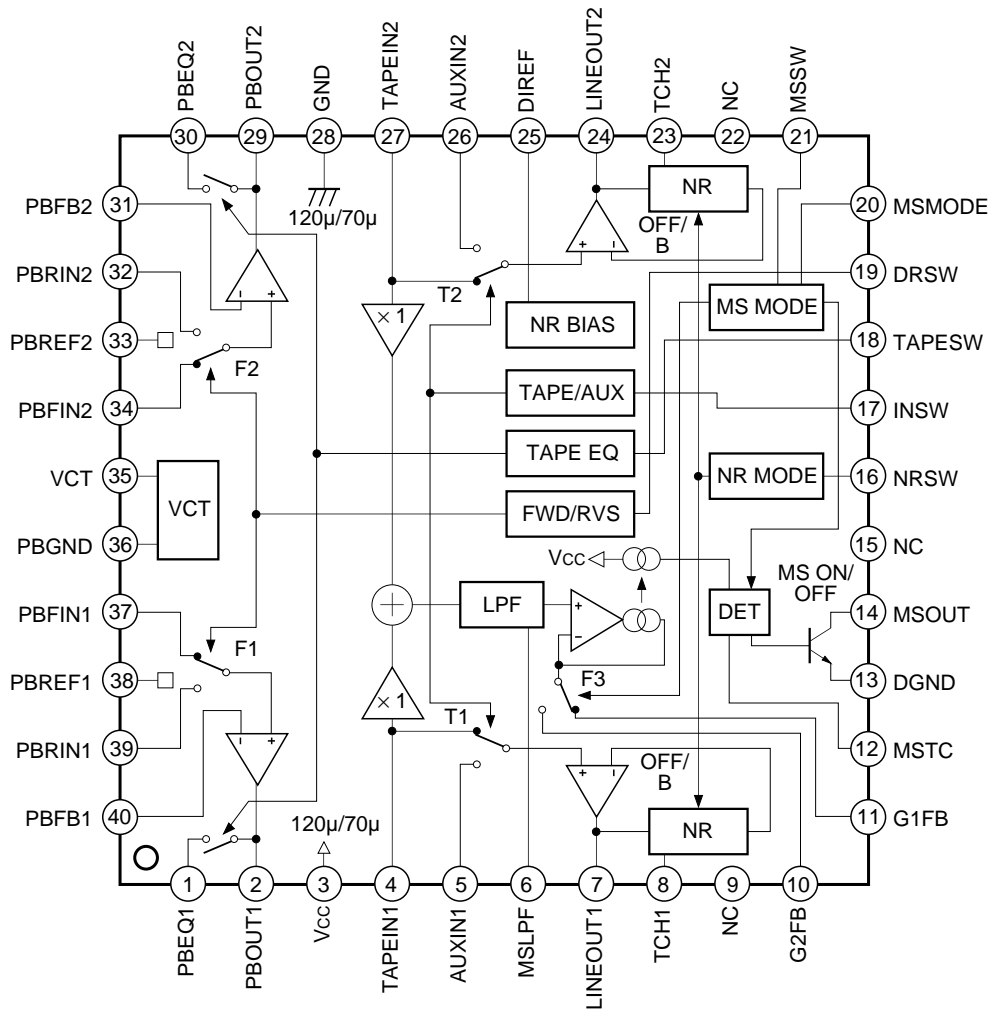

Pin Description

(Ta = 25°C, Vcc = 8.0V, DVcc = 5.0V)

Pin No.	Symbol	Typical pin voltage		I/O	I/O resistance	Equivalent circuit	Description
		DC	AC				
1 30	PBEQ1 PBEQ2	4.0V	—	O	—		Resistance for selecting the playback equalizer amplifier time constant
2 29	PBOUT1 PBOUT2	4.0V	-25dBm	O	—		Playback equalizer amplifier output
3	Vcc	8.0V	—	—	—		Power supply
4 27	TAPEIN1 TAPEIN2	4.0V	-30dBm	I	40kΩ		TAPE input
5 26	AUXIN1 AUXIN2						External input
6	MSLPF	4.0V	—	—	100kΩ		Cut-off frequency adjustment of the music sensor LPF

Pin No.	Symbol	Typical pin voltage		I/O	I/O resistance	Equivalent circuit	Description
		DC	AC				
7 24	LINEOUT1 LINEOUT2	4.0V	-6dBm	O	—		Line output
8 23	TCH1 TCH2	0.3V	—	—	—		Time constant for the HLS
10 11	G2FB G1FB	4.0V	—	—	—		Music signal interval detection level setting
12	MSTC	—	—	—	—		Time constant for detecting the music signal interval
13	DGND	0.0V	—	—	—		Logic ground (Connect to GND.)

Pin No.	Symbol	Typical pin voltage		I/O	I/O resistance	Equivalent circuit	Description
		DC	AC				
14	MSOUT	0.2V when a signal is detected; DVcc when no signal is detected	—	O	—		Time constant for detecting the music signal interval
17	INSW	0.0V when open	—	I	100kΩ		Line amplifier input select control Low (open): TAPEIN High: AUXIN
21	MSSW						Music sensor control Low (open): MS ON High: MS OFF
16	NRSW	0.0V when open	—	I	100kΩ		Dolby NR control Low (open): NR OFF High: NR ON
18	TAPESW						Playback equalizer amplifier control Low (open): 120μs High: 70μs
19	DRSW						Head select control Low (open): FORWARD High: REVERSE
20	MSMODE	0.0V when open	—	I	100kΩ		Music sensor mode control Low (open): G1 High: G2

Pin No.	Symbol	Typical pin voltage		I/O	I/O resistance	Equivalent circuit	Description
		DC	AC				
25	DIREF	1.2V	—	—	—		Resistance for setting the Dolby NR reference current (Connects 18kΩ between DIREF pin and GND for the standard setting.)
28	GND	0.0V	—	—	—		Ground
31 40	PBFB2 PBFB1	4.0V	-70dBm	I	—		Playback equalizer amplifier feedback
32 39	PBRIN2 PBRIN1	4.0V	-70dBm	I	—		Playback equalizer amplifier input (REVERSE head connected)
34 37	PBFIN2 PBFIN1						Playback equalizer amplifier input (FORWARD head connected)
33 38	PBREF2 PBREF1	4.0V	—	O	—		Playback equalizer amplifier reference (Vcc/2 output)

Pin No.	Symbol	Typical pin voltage		I/O	I/O resistance	Equivalent circuit	Description
		DC	AC				
35	VCT	4.0V	—	O	—		Center (Vcc/2 output)
36	PBGND	0.0V	—	—	—		Playback equalizer amplifier ground (Connect to ground.)
9 15 22	NC	—	—	—	—		No connected

Electrical Characteristics

(Ta = 25°C, Vcc = 8.0V. DVcc = 5.0V)

Item	Symbol	Measurement conditions	Min.	Typ.	Max.	Unit
Operating voltage	Vopr		7.8	8.0	11.0	V
Current consumption	Icc	No signal, NR OFF, TAPE, 120μs, MS ON	7.6	11.6	15.6	mA
Dolby NR (0dB = Dolby level LINEOUT of -6dBm)						
TAPEIN input sensitivity	V _{TIN}	TAPEIN 1kHz, LINEOUT 0dB, NR OFF	-32.0	-30.0	-28.0	dBm
AUXIN input sensitivity	V _{AUX}	AUXIN 1kHz, LINEOUT 0dB	-32.0	-30.0	-28.0	dBm
B type decode boost characteristics 1	BP1	TAPEIN 500Hz, LINEOUT -25dB, NR ON	1.4	2.9	4.4	dB
B type decode boost characteristics 2	BP2	TAPEIN 2kHz, LINEOUT -25dB, NR ON	5.5	7.0	8.5	dB
B type decode boost characteristics 3	BP3	TAPEIN 5kHz, LINEOUT -25dB, NR ON	3.9	5.4	6.9	dB
B type decode boost characteristics 4	BP4	TAPEIN 10kHz, LINEOUT -40dB, NR ON	9.7	10.4	11.9	dB
B type decode boost characteristics 5	BP5	TAPEIN 10kHz, LINEOUT 0dB, NR ON	-1.1	0.4	1.9	dB
Total harmonic distortion 1	THD1	TAPEIN 1kHz -20dBm, NR OFF, RL = 2.7kΩ	—	0.01	0.2	%
Total harmonic distortion 2	THD2	TAPEIN 1kHz -20dBm, NR ON, RL = 2.7kΩ	—	0.04	0.2	%
Decode S/N ratio	SN1	No signal, NR ON, Rg = 5.1kΩ, CCIR/ARM filter used	77.0	87.0	—	dB
Signal handling	SH1	TAPEIN 1kHz, NR OFF, RL = 2.7kΩ, THD = 1%	13.0	14.4	—	dB
Crosstalk between channels 1	CT1	TAPEIN 1kHz -24dBm, NR OFF, 1kHz BPF used	—	-86.0	-70.0	dB
Crosstalk between channels 2	CT2	AUXIN 1kHz -24dBm, 1kHz BPF used	—	-86.0	-70.0	dB
Crosstalk between TAPE and AUX	CT3	TAPE (AUX) IN 1kHz -24dBm, NR OFF, AUX (TAPE) mode, 1kHz BPF used*1	—	-67.0	-65.0	dB
Output DC offset voltage	Vos1	No signal, NR OFF, difference from VCT	-0.1	0.0	0.1	V
Playback Equalizer Amplifier						
Playback equalizer amplifier reference output level	PBREF	PBIN 315Hz -70dBm, 120μs mode	-27.0	-25.0	-23.0	dBm
Playback equalizer amplifier frequency response 1	F120	PBIN 2.7kHz -58.5dBm, 120μs mode at 315Hz	-1.5	0.0	1.5	dB
Playback equalizer amplifier frequency response 2	F70	PBIN 4.5kHz -53.8dBm, 70μs mode at 315Hz	-1.5	0.0	1.5	dB
Signal handling	SH2	PBIN 1kHz, 120μs mode, RL = 2.7kΩ, THD = 1%	-10.0	-3.0	—	dBm
Total harmonic distortion	THD3	PBIN 1kHz -52dBm, 120μs mode, RL = 2.7kΩ	—	0.07	0.5	%
S/N ratio	SN2	No signal, 70μs mode, Rg = 680Ω, CCIR/ARM filter used	59.0	64.5	—	dB

Item	Symbol	Measurement conditions	Min.	Typ.	Max.	Unit
Output DC offset voltage	V _{OS2}	No signal, 120μs mode, R _g = 680Ω, difference from VCT	-1.0	0.0	1.0	V
Crosstalk between channels	CT4	PBIN 1kHz -42dBm, 120μs mode, 1kHz BPF used	—	-81.0	-70.0	dB
Crosstalk between FORWARD and REVERSE	CT5	PBIN 1kHz -42dBm, 120μs mode, 1kHz BPF used	—	-80.0	-70.0	dB
Music Sensor						
Signal detection level 1	V _{MS1}	TAPEIN 5kHz, MS ON, G1 mode, external constant of 39kΩ and 0.0047μF	-43.0	-40.0	-37.0	dBm
Signal detection level 2	V _{MS2}	TAPEIN 5kHz, MS ON, G2 mode, external constant of 3.9kΩ and 0.47μF	-63.0	-60.0	-57.0	dBm
MS output leak current	I _{OH}	No signal, MS OFF, G1 mode	—	0.0	1.0	μA
MS output saturation voltage	V _{OL}	TAPEIN 5kHz -30dBm, MS ON, G1 mode, 1mA applied to MSOUT pin	—	0.3	1.0	V
Logic Voltage						
Low level	V _{IL}	Input voltage of NRSW, INSW, TAPESW, DRSW, MSMODE, MSSW	0.0	—	0.5	V
High level	V _{IH}	Input voltage of NRSW, INSW, TAPESW, DRSW, MSMODE, MSSW	2.5	—	DV _{CC}	V

*1 The crosstalk between TAPE and AUX is measured with a 5.1kΩ external resistor connected to AUXIN1 (Pin 5). In this condition, the crosstalk is approximately -67dB due to the signal leak from MSLPF (Pin 6). In order to improve the crosstalk between TAPE and AUX, AUXIN1 pin should be driven with a low impedance.

Electrical Characteristics Measurement Circuit

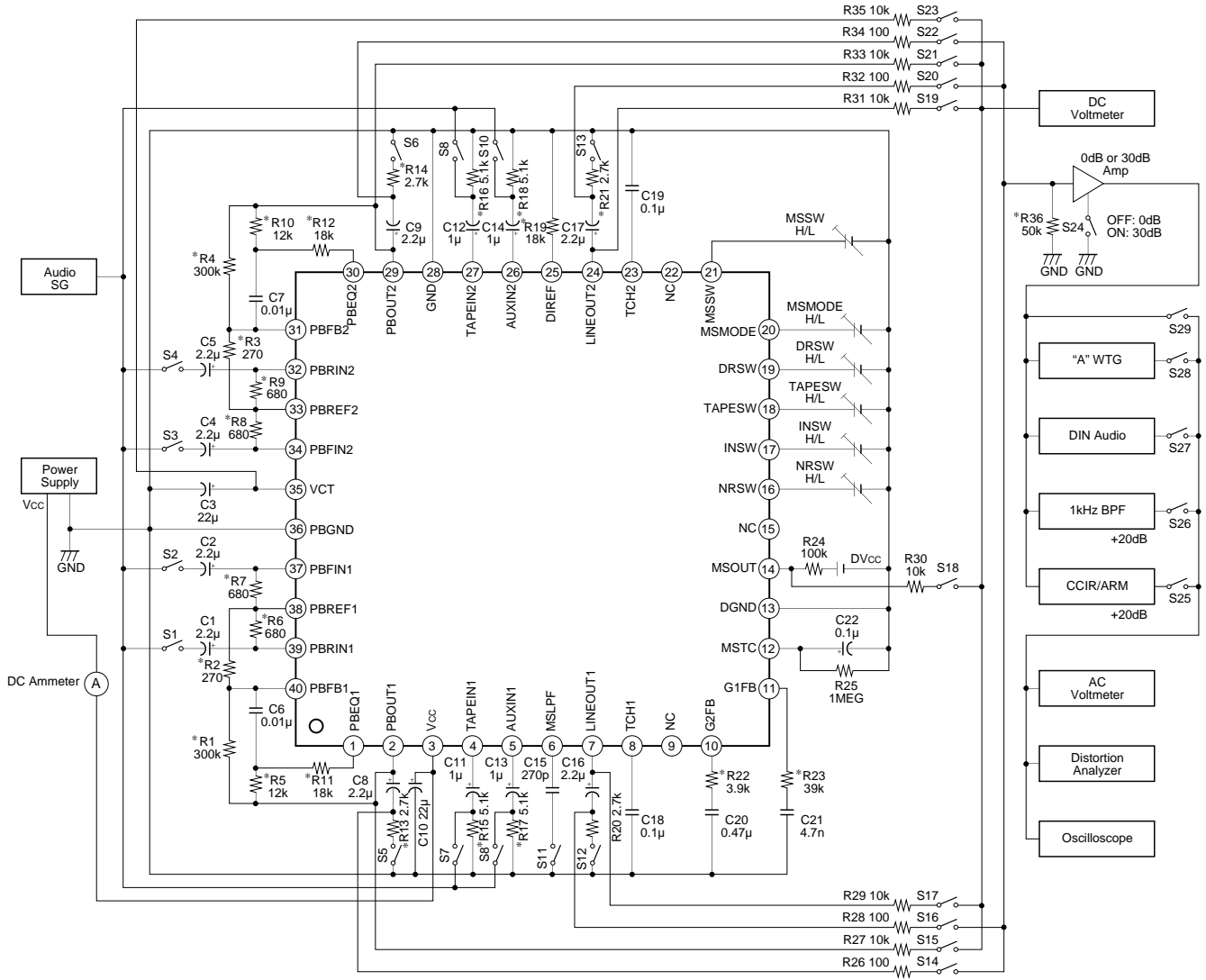

Note 1. Resistor tolerance ±5%
 *: ±1%
 2. Capacitor tolerance ±5%
 *: ±2%
 Coupling Capacitor ±10%

Application Circuit 1

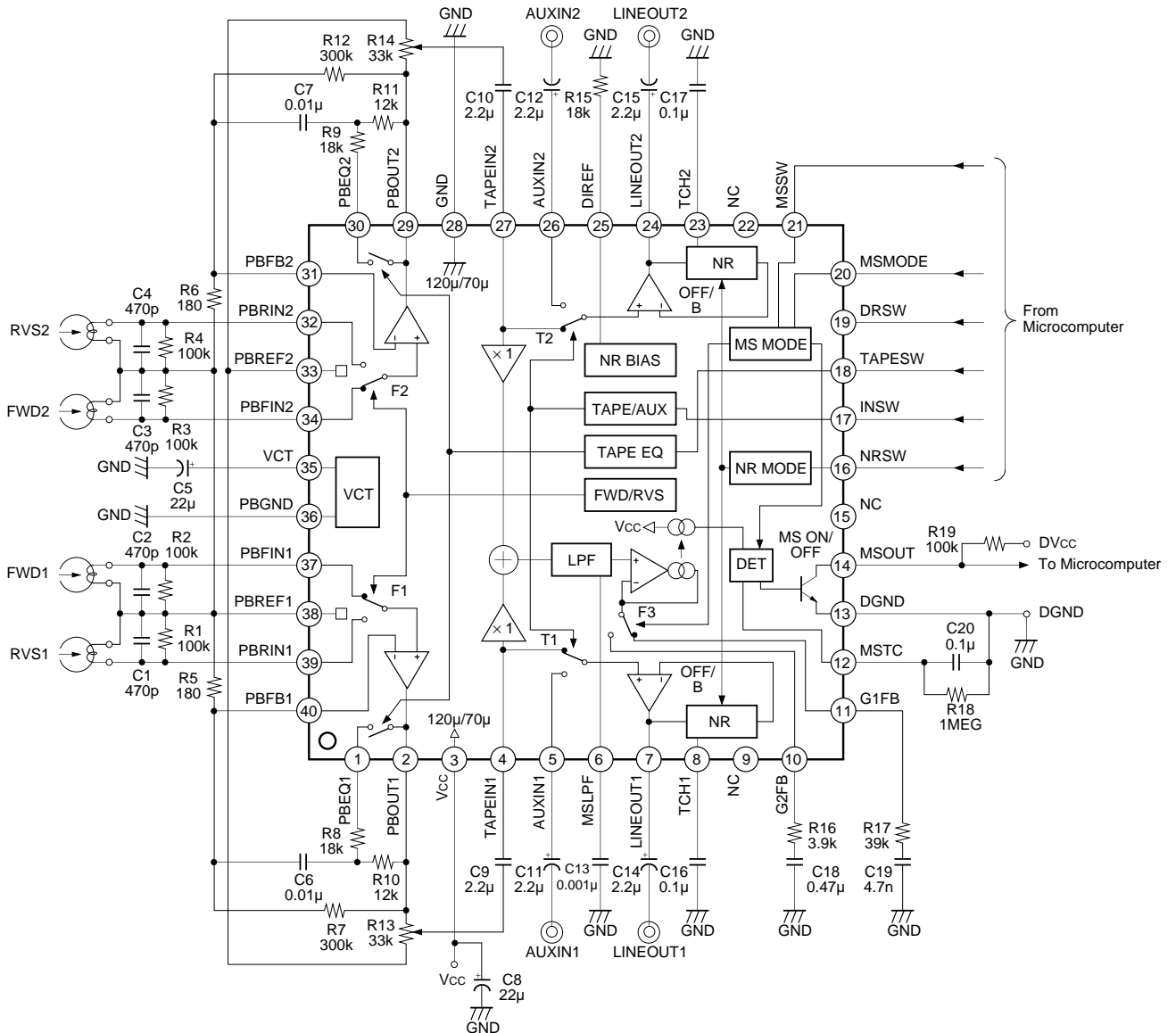

Application circuits shown are typical examples illustrating the operation of the devices. Sony cannot assume responsibility for any problems arising out of the use of these circuits or for any infringement of third party patent and other right due to same.

Application Circuit 2

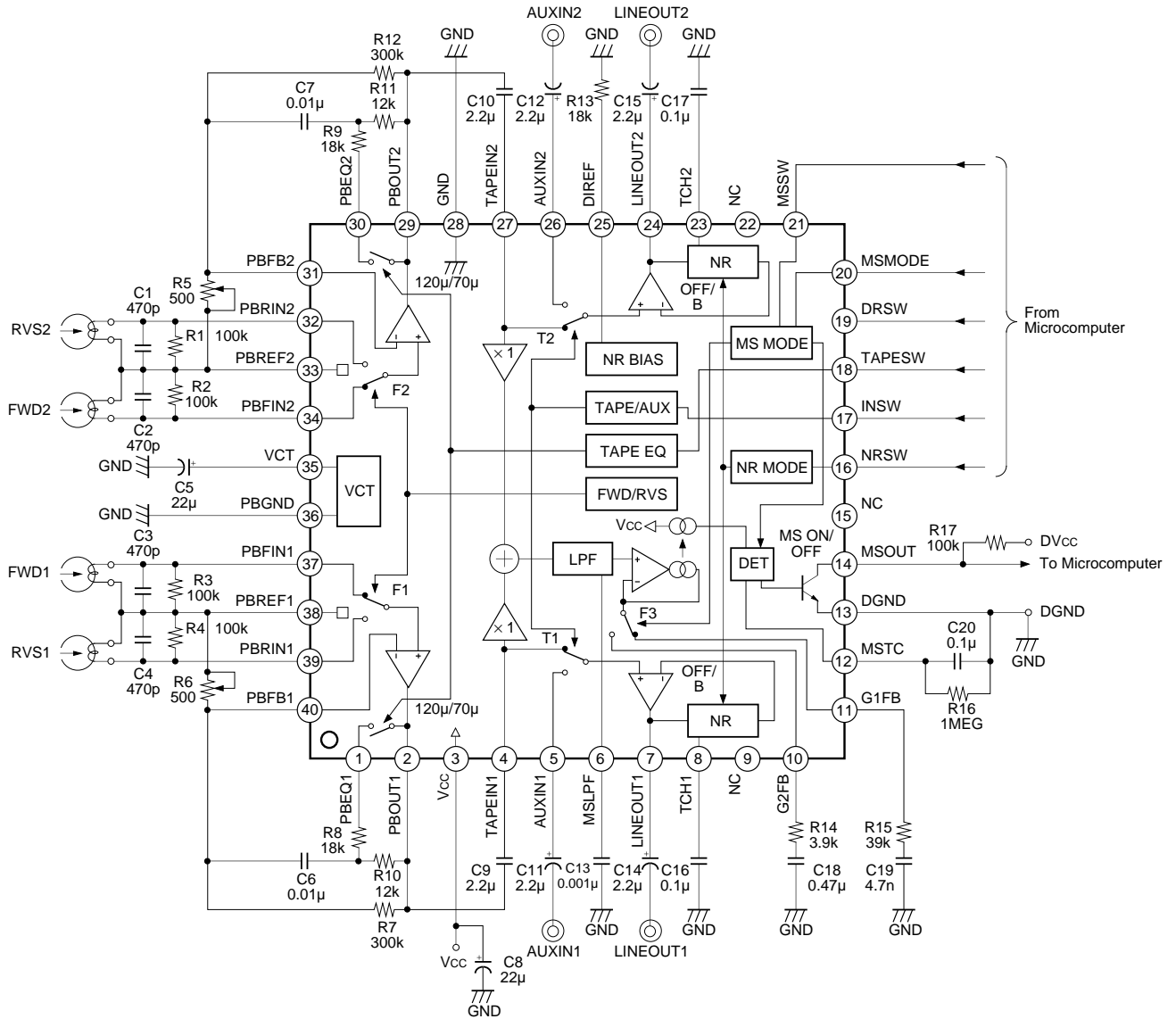

Application circuits shown are typical examples illustrating the operation of the devices. Sony cannot assume responsibility for any problems arising out of the use of these circuits or for any infringement of third party patent and other right due to same.

Description of Operation

1. Signal route

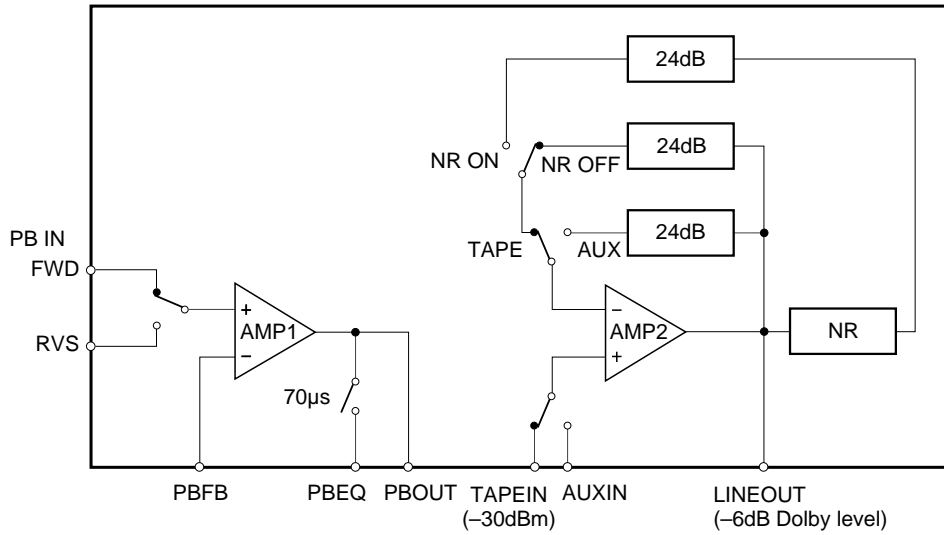

Fig. 1. Signal route block diagram

AMP1 and AMP2 are operational amplifiers. AMP1 composes the playback equalizer amplifier by attaching an external resistor and capacitor to PBF, PBEQ and PBOUT pins.

AMP2 is an input selector and a line amplifier. The gain is 24 dB when NR is OFF.

The Dolby NR reference level is -6dBm (LINEOUT).

2. Adjustment method

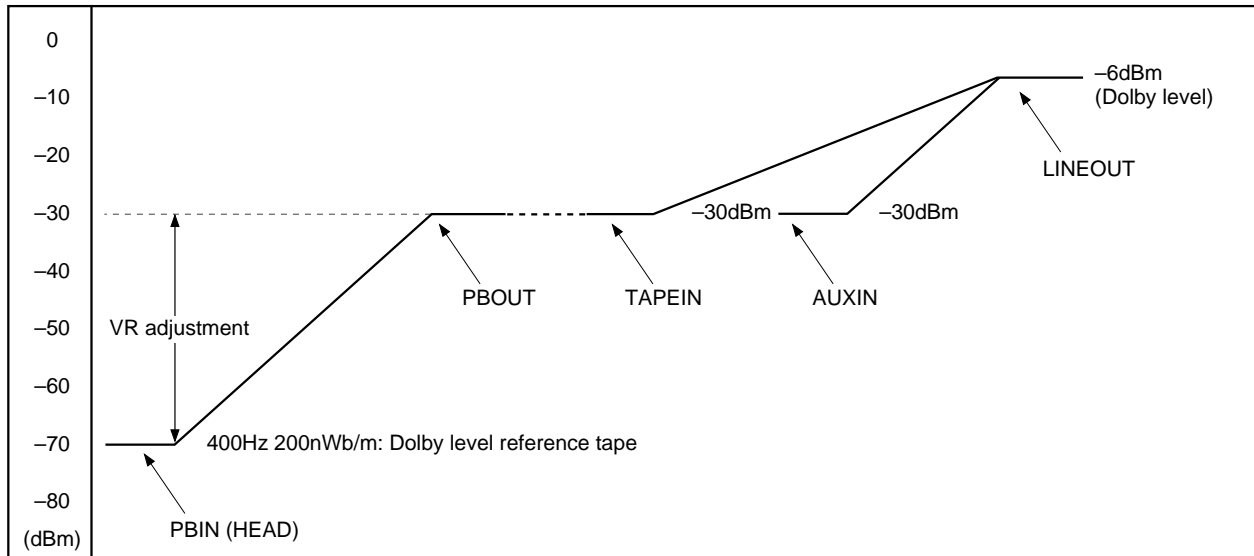

Fig. 2-1. Level diagram (application circuit 1)

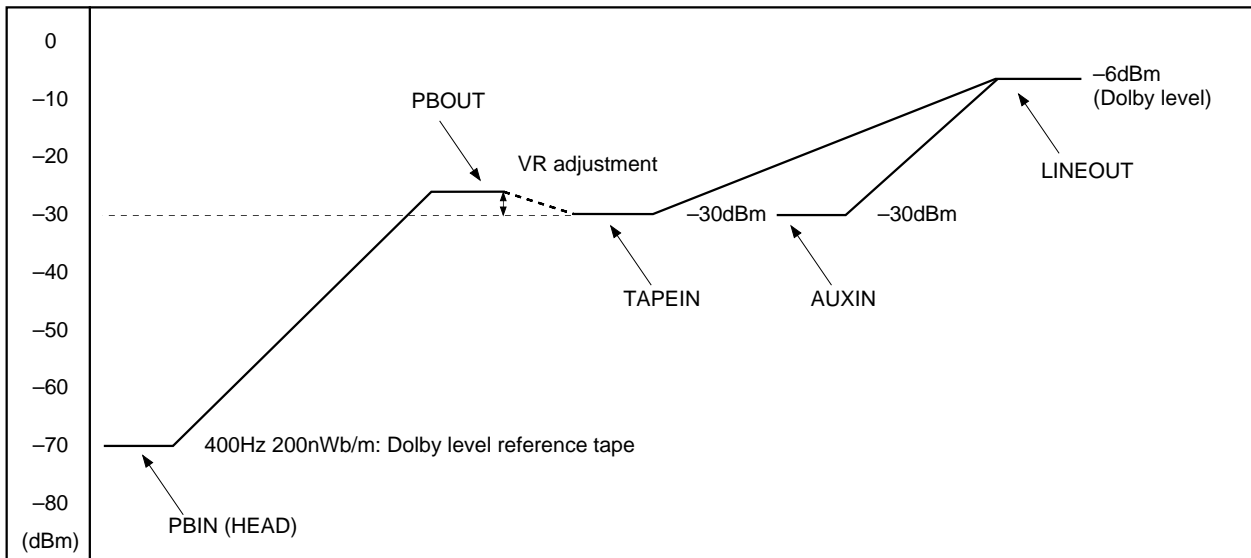

Fig. 2-2. Level diagram (application circuit 2)

Adjust the playback equalizer amplifier gain so that -6dBm (Dolby level) is output on LINEOUT (Pins 7 and 24) by playing back the reference tape for Dolby level adjustment.

Adjustment should be performed according to the rules of Dolby Laboratories Licensing Corporation because this IC has the built-in Dolby NR system.

List of Calibration Cassette Tape

Dolby level is defined as 200nWb/m measured according to the ANSI high efficiency head method. The followings are the reference tapes specified by Dolby Laboratories Licensing Corporation.

1. A-bex Laboratories, Inc. (part no. TCC-130)
2. BASF (product code 09797 XE)
3. Kaneon Corp. (LC Engineering part no. LCT-7001)
4. Standard Tape Laboratory (catalogue no. 28)
5. TEAC Corporation, Japan (part no. MTT150)
6. TEAC Corporation of America (part no. MTT150)
7. Victor Company of Japan, Ltd. (part no. TMT-6130, VTT-727)
8. Sony Corporation (part no. TY-256)

3. Playback equalizer amplifier

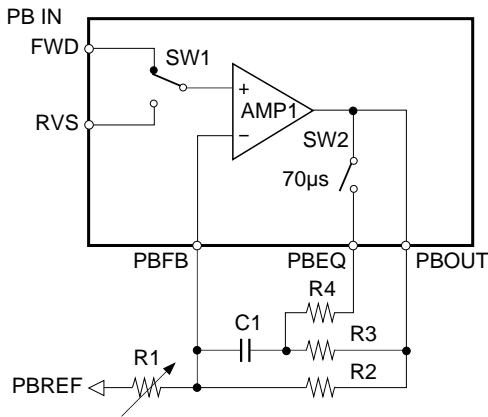

Fig. 3. Playback equalizer amplifier block diagram

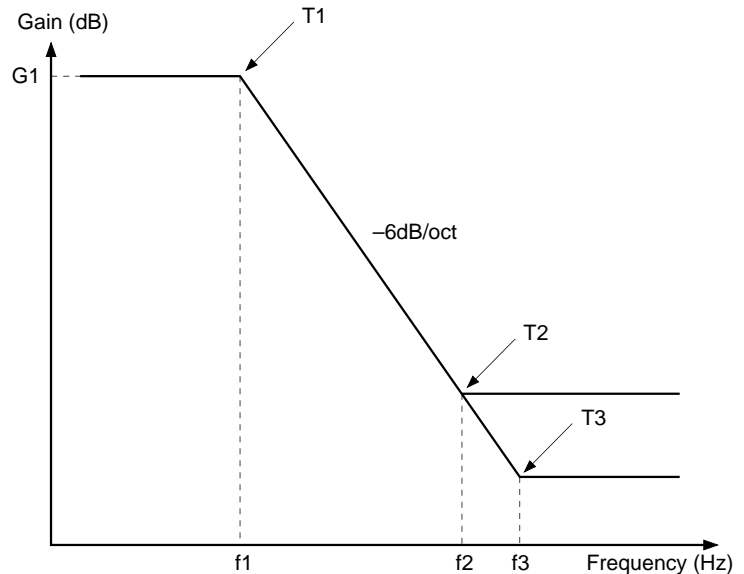

Fig. 4. Playback equalizer amplifier frequency response

The CXA2510AQ achieves the frequency response of Fig.4 with the circuit configuration shown in Fig. 3.

Two systems (FORWARD and REVERSE) of playback head input are provided for each channel.

The FORWARD input pin is selected when DRSW (Pin 19) is Low; REVERSE is selected when DRSW is High.

The playback equalizer amplifier frequency response can be set in two levels.

When TAPESW (Pin 18) is Low, SW2 shown in Fig. 3 is turned OFF; when TAPESW is High, SW2 is turned ON.

The external resistance R1 should be adjusted to adjust the playback equalizer amplifier gain.

The playback equalizer amplifier frequency response is all determined by the external resistance and capacitance, and it can be obtained with the following equation.

$$G(s) = \frac{R1 + R2}{R1} \cdot \frac{1 + \{s \cdot C1 \cdot (R1 \cdot R2 + R2 \cdot Rx + Rx \cdot R1) / (R1 + R2)\}}{1 + s \cdot C1 \cdot (R2 + Rx)} \quad (s = j\omega)$$

Where, Rx = R3 when TAPESW pin =Low;

Rx = R3//R4 when TAPESW pin = High

Using the above equation, G1 in Fig. 3 and low-frequency time constant (T1) and high-frequency time constants (T2 and T3) are as follows:

$$G1 = 20\log \frac{R1 + R2}{R1}$$

$$T1 = C1 \cdot (R2 + Rx)$$

$$T2, T3 = \frac{C1 \cdot (R1 \cdot R2 + R2 \cdot Rx + Rx \cdot R1)}{R1 + R2}$$

4. Music sensor

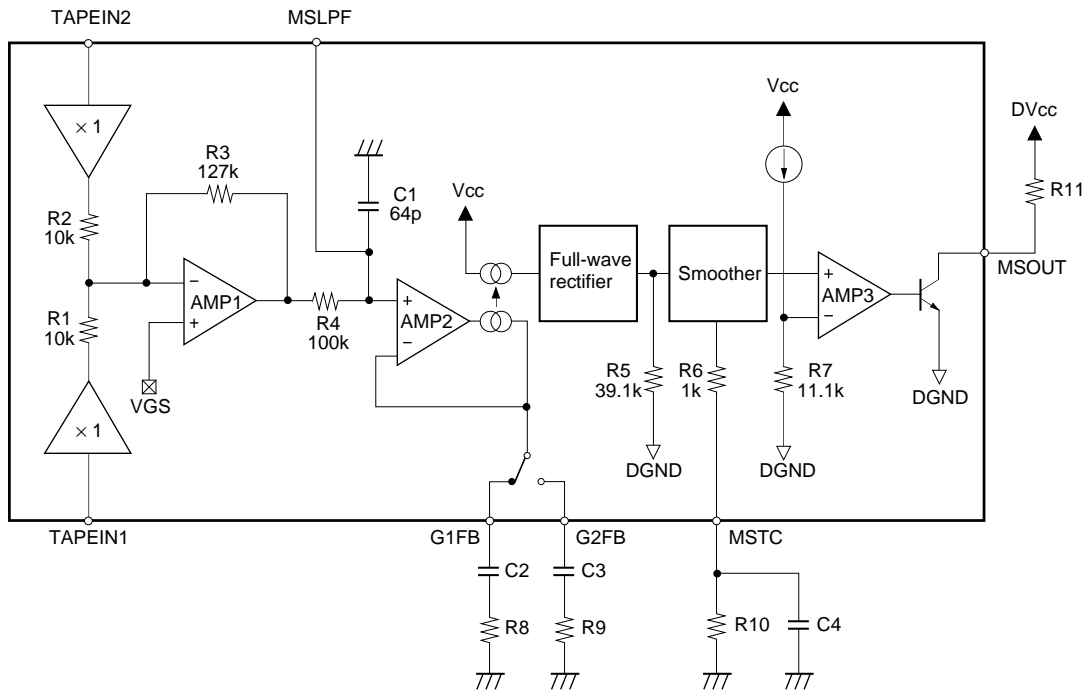

Fig. 5. Music sensor block diagram

The signal input from TAPEIN is added and amplified by AMP1. This signal is then input to the LPF (R4 and C1). The LPF cut-off frequency can be adjusted by connecting the external capacitance to MSLPF pin. The cut-off frequency is approximately 23kHz when MSLPF pin is left open.

The detection level and HPF cut-off frequency are determined with the external resistance and capacitance connected to G1FB or G2FB at AMP2, and the signal is converted to a current.

The signal is full-wave rectified and is converted to a voltage by the internal resistance R5.

The full-wave rectified signal is smoothed. The internal resistance (R6) and external capacitance (C4) determine the smoothing response time. The recovery time is determined by the external resistance (R10) and capacitance (C4).

The AMP3 comparator detects whether the smoothed signal is greater or smaller than the comparator threshold.

The comparator has approximately 2dB hysteresis.

The table below shows the example of the constant and characteristics for the external resistance and capacitance connected to G1FB and G2FB.

	R	C	Music signal detection level	Music signal interval detection level	Cut-off frequency
FF/REW (G1)	39kΩ	0.0047μF	-39.5dBm	-41.4dBm	870Hz
Playback (G2)	3.9kΩ	0.47μF	-59.5dBm	-61.4dBm	87Hz

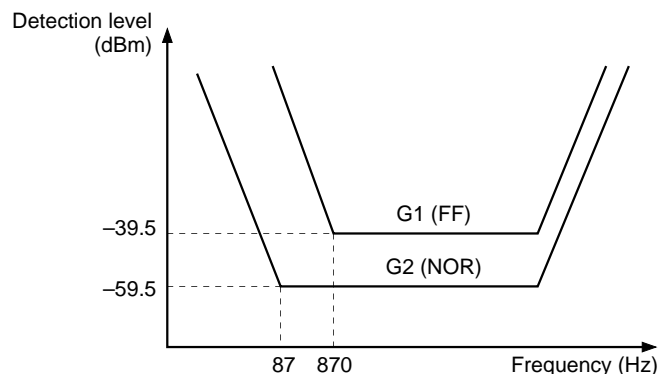

Fig. 6. Music sensor circuit frequency response

5. Operating mode control method

The CXA2510AQ has a Dolby NR switch (NRSW), playback equalizer amplifier select switch (TAPESW), head input select switch (DRSW), music sensor mode select switch (MSMODE) and music sensor switch (MSSW). The operating modes for each switch are shown in the following table.

Pin No.	Pin name	Pin voltage	
		Low (OPEN)	High
16	NRSW	Dolby NR OFF	Dolby NR ON
17	INSW	TAPE	AUX
18	TAPESW	120 μ s	70 μ s
19	DRSW	PBIN FORWARD	PBIN REVERSE
20	MSMODE	G1	G2
21	MSSW	MS ON	MS OFF

Notes on Operation

1. Dolby NR

Dolby NR functions by using the current that flows into DIREF (Pin 25) as standard.

The Dolby NR attack/recovery time is determined by the capacitance connected to TCH (Pins 8 and 23).

Use the parts connected to these pins with high accuracy and small temperature characteristics.

(It is recommended that the resistance tolerance of 2% <metal-oxide> and capacitance tolerance of 10% <film>.)

2. Playback equalizer amplifier

All playback equalizer amplifier characteristics are determined by the external constants. Use the parts which satisfies the accuracy required for the playback equalizer amplifier.

3. Music sensor

The current on DIREF (Pin 25), and the resistance and capacitance connected to G2FB (Pin 10) and G1FB (Pin 11) determine the detection level and the HPF cut-off frequency.

The response time is determined by the resistance and capacitance connected to MSTC (Pin 12).

Use the parts which satisfies the accuracy required for the music sensor.

Example of Representative Characteristics

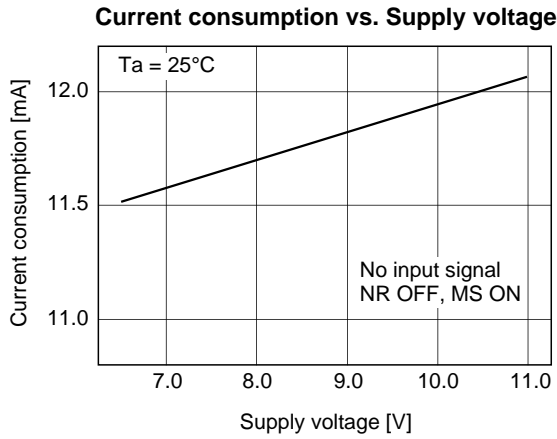

Playback equalizer amplifier frequency response

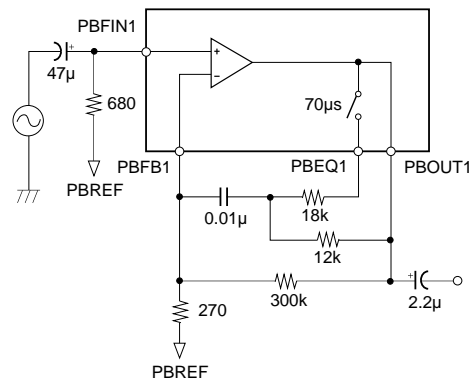
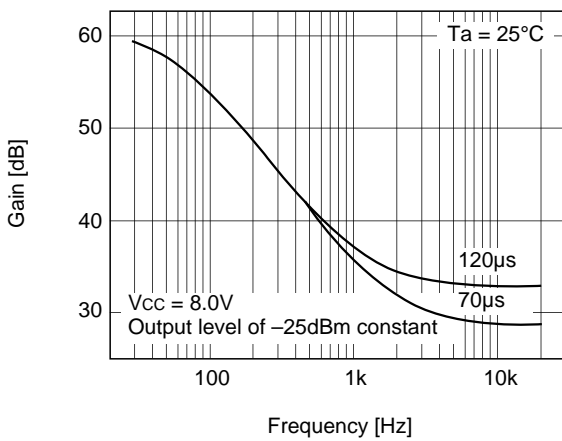
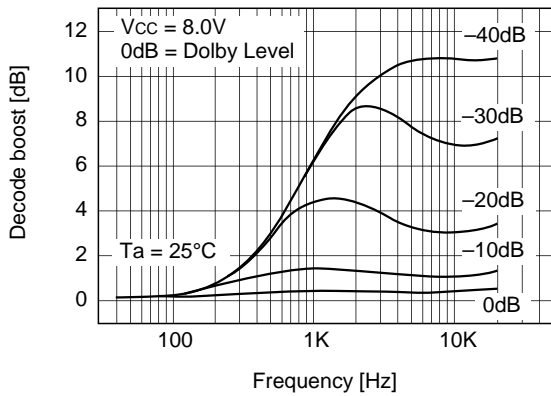
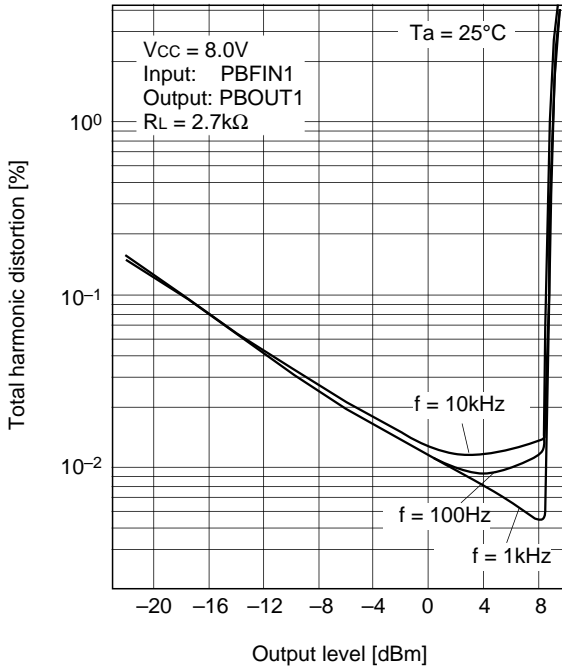

Fig. 7. Measurement circuit of playback equalizer amplifier frequency response

B type decode boost characteristics



Total harmonic distortion (playback equalizer amplifier)



B type total harmonic distortion (including NR OFF)

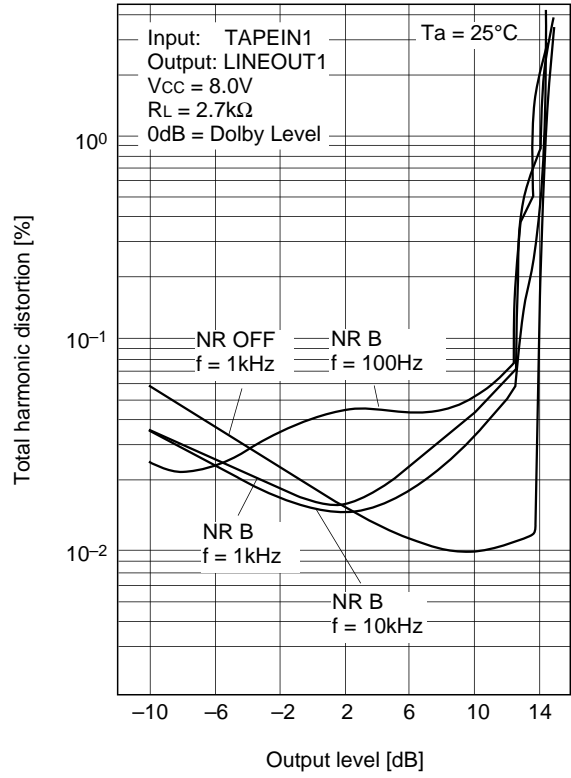

Ripple rejection ratio (PBOUT)

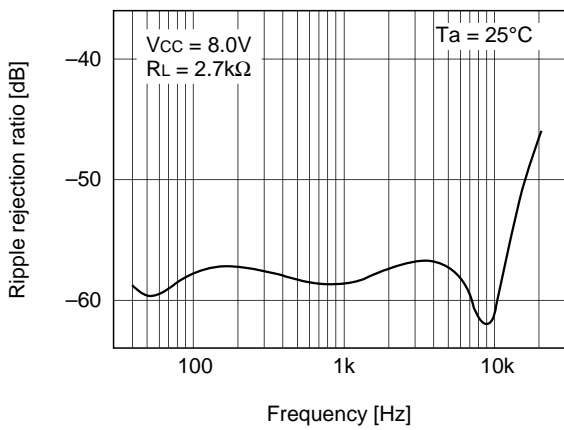

Ripple rejection ratio (LINEOUT)

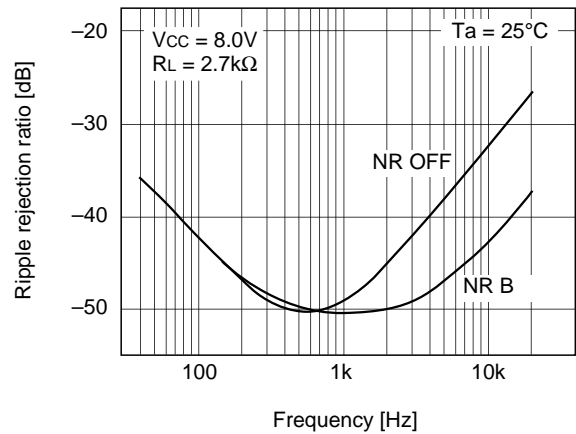

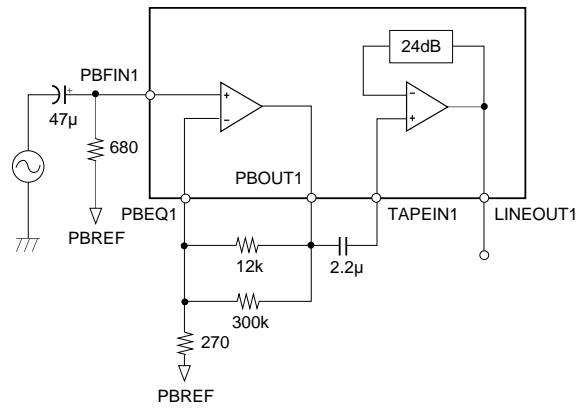
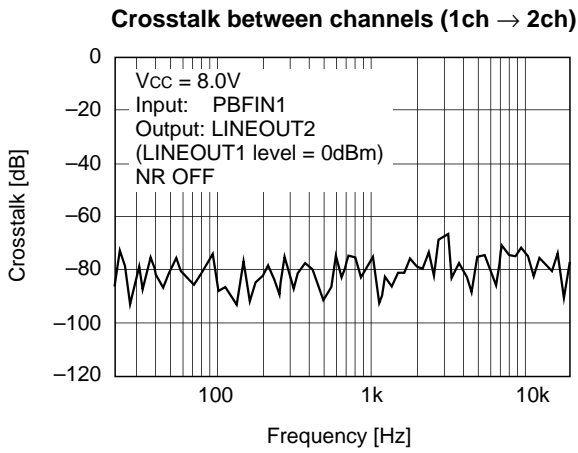
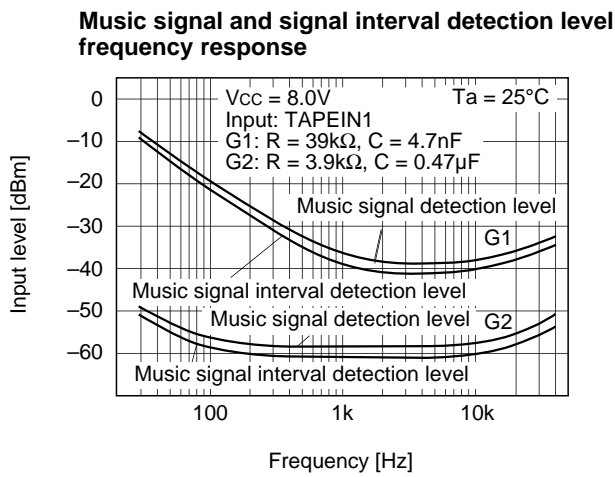
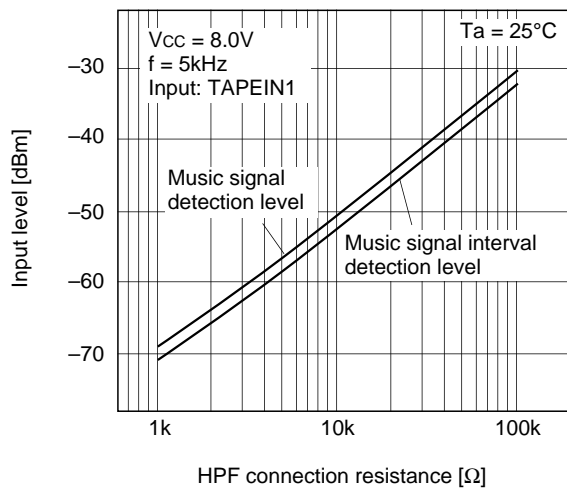

Fig. 8. Measurement circuit of crosstalk between channels



HPF connection resistance in MS block vs. Music signal and signal interval detection level characteristics



Package Outline

Unit: mm

40PIN QFP (PLASTIC)

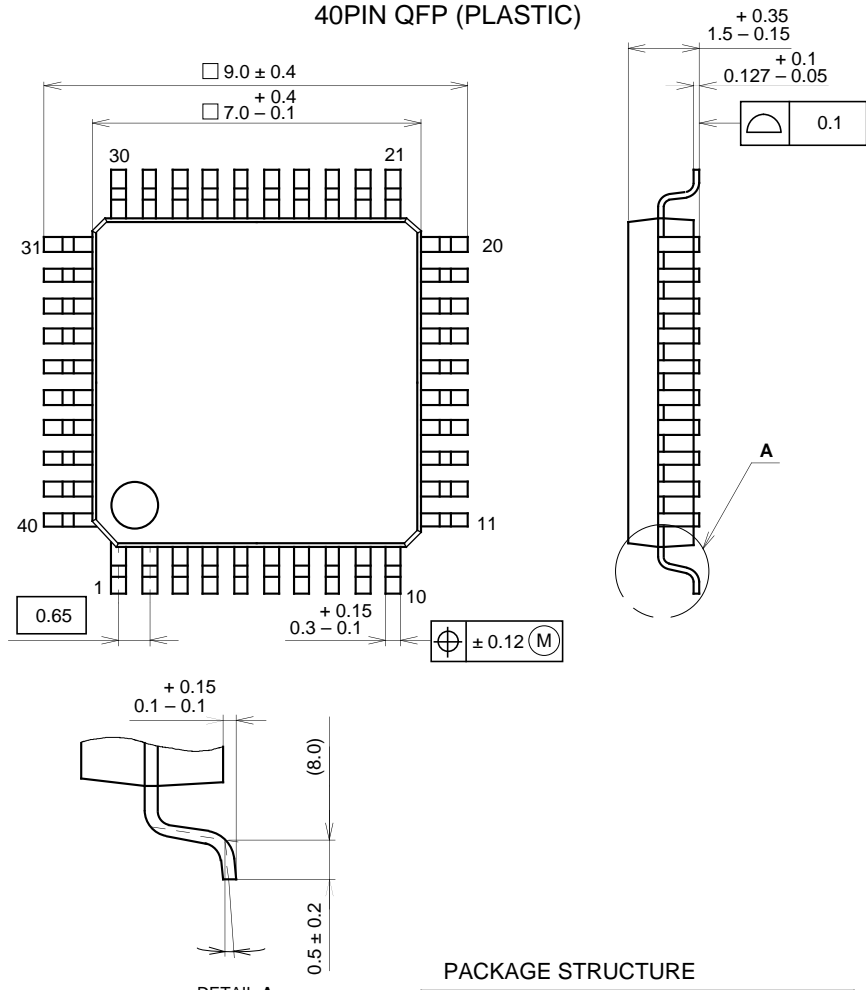

SONY CODE	QFP-40P-L01
EIAJ CODE	QFP040-P-0707
JEDEC CODE	_____

PACKAGE STRUCTURE

PACKAGE MATERIAL	EPOXY RESIN
LEAD TREATMENT	SOLDER / PALLADIUM PLATING
LEAD MATERIAL	42/COPPER ALLOY
PACKAGE MASS	0.2g

NOTE : PALLADIUM PLATING

This product uses S-PdPPF (Sony Spec.-Palladium Pre-Plated Lead Frame).