

SONY

CXA2534Q

4-Channel CD Motor Driver

Description

CXA2534Q is a 4-channel H-bridge motor driver IC designed for portable CD systems. It has a built-in DC to DC converter controller that allows voltage step-up to typically 3.2 V; this voltage can be used to power the system DSP, SSP and micro-controller. In addition, it also provides a PWM regulated power supply to the H-bridge output stage so as to ensure high efficiency.

Features

- 4 channels of H-bridge drivers
- PWM regulated power supply for H-bridge output stages
- Step-up DC to DC converter controller for system power supply
- Start and off controls with soft start capability
- Reset pulse
- Short circuit protect
- Over-voltage protect
- Low battery voltage detection
- Rechargeable battery charger
- General purpose operational amplifier
- Thermal shut-down for battery charger and H-bridge driver (170 °C/140 °C)
- Direct interface with wired remote controller possible

Applications

Portable CD player

Structure

Bipolar silicon monolithic IC

48 pin QFP (Plastic)

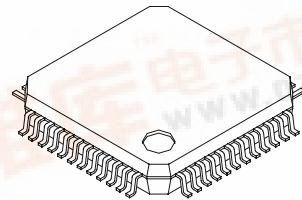

Sony reserves the right to change products and specifications without prior notice. This information does not convey any license by any implication or otherwise under any patents or other right. Application circuits shown, if any, are typical examples illustrating the operation of the devices. Sony cannot assume responsibility for any problems arising out of the use of these circuits.



Absolute Maximum Ratings (Ta=25 °C)

| Item | Symbol | Rating | Unit |
|--------------------------------|------------------|-------------|------|
| Supply voltage | Vcc1, Vcc2, PVcc | 13.5 | V |
| Spindle channel output current | Io (spindle) | 400 | mA |
| Sled channel output current | Io (sled) | 300 | mA |
| Focus channel output current | Io (focus) | 200 | mA |
| Track channel output current | Io (track) | 200 | mA |
| Allowable power dissipation | Pd | 660 | mW |
| operating temperature | Topr | -20 to +75 | °C |
| Storage temperature | Tstg | -65 to +150 | °C |

Recommended Operating Conditions (Ta=25 °C)

| Item | Symbol | Min | Typ | Max | Unit |
|--------------------------------|--------|-----|-----|------|------|
| System 1 supply voltage | Vcc1 | 2.7 | 3.2 | 5.5 | V |
| System 2 supply voltage | Vcc2 | 2.7 | 3.2 | 5.5 | V |
| Power Vcc | PVcc | — | PWM | Batt | V |
| Battery supply voltage | Batt | 1.5 | 2.4 | 8 | V |
| Battery charger supply voltage | ChgVcc | 3 | 4.5 | 8 | V |
| Operating temperature | Ta | -10 | 25 | 70 | °C |

Block Diagram

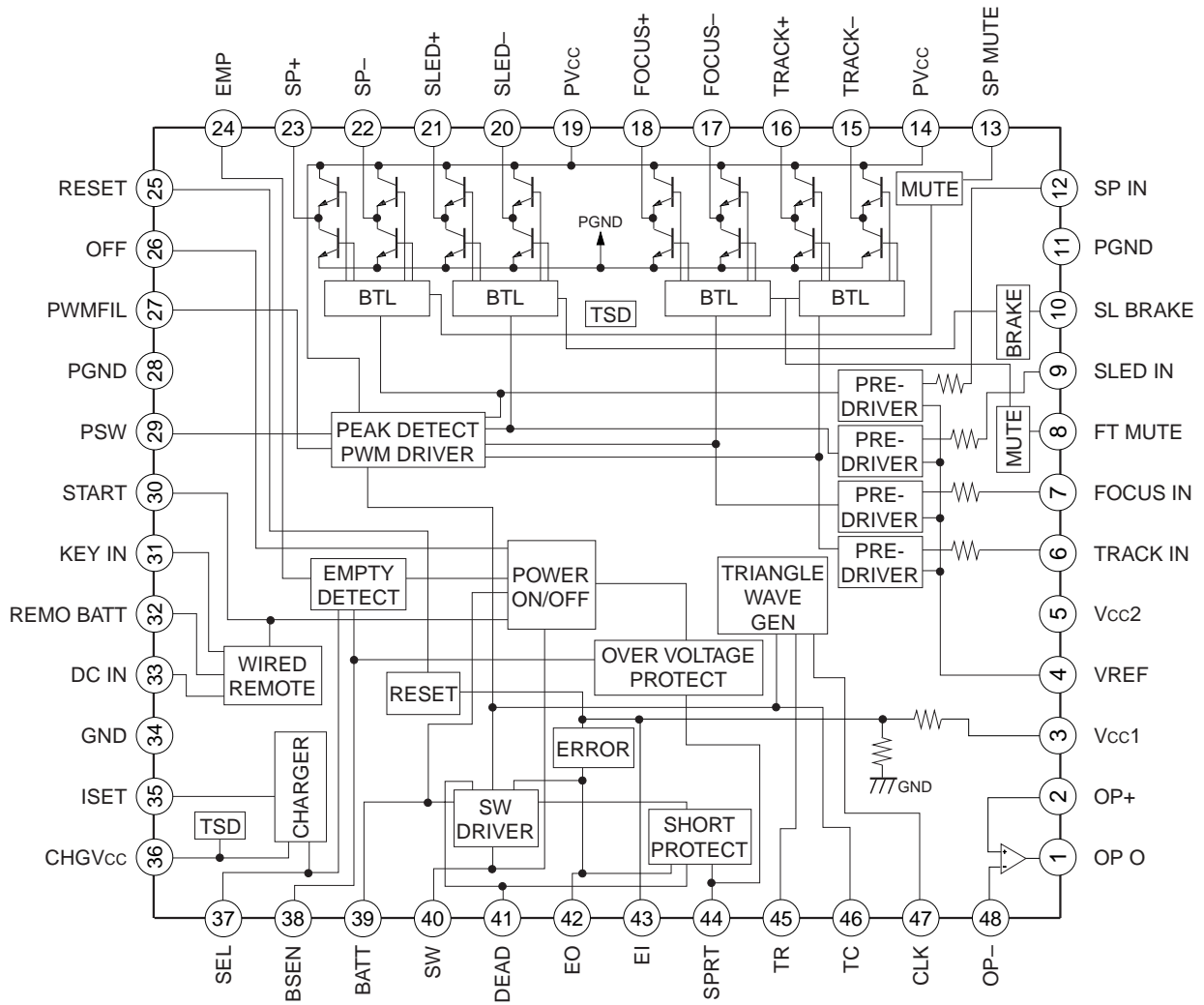

Pin Description

| Pin No. | Symbol | Pin Voltage | Equivalent circuit | Description |
|---------|--------|-------------|--------------------|--|
| 1 | OP O | — | | Output pin of built-in operational amplifier |
| 2 | OP+ | — | | Non-inverting input pin of operational amplifier |
| 48 | OP- | | | Inverting input pin of operational amplifier |
| 3 | Vcc1 | 3.2 V | | Power supply input to DC-DC controller circuits |
| 4 | VREF | 1.6 V | | Reference Voltage |
| 5 | Vcc2 | 3.2 V | | Power supply input to pre-driver circuits |

| Pin No. | Symbol | Pin Voltage | Equivalent circuit | Description |
|---------|----------|-------------|--------------------|-----------------------------------|
| 6 | TRACK IN | 1.6 V | | Tracking error signal input pin |
| 7 | FOCUS IN | | | Focus error signal input pin |
| 9 | SLED IN | | | Sled error signal input pin |
| 8 | FT MUTE | 0 V | | Focus and Tracking mute input pin |
| 10 | SL BRAKE | | | Sled motor brake input pin |
| 11 | PGND | 0 V | | Power ground for H-bridge drivers |
| 28 | | | | |
| 12 | SP IN | 1.6 V | | Spindle error signal input pin |
| 13 | SP MUTE | 0 V | | Spindle mute input |

| Pin No. | Symbol | Pin Voltage | Equivalent circuit | Description |
|---------|--------|-------------|--------------------|---|
| 14 | PVcc | — | | Power supply input for H-bridge drivers |
| 19 | | | | |
| 15 | TRACK- | — | | Negative output pin to tracking motor |
| 16 | TRACK+ | | | Positive output pin to tracking motor |
| 17 | FOCUS- | | | Negative output pin to focus motor |
| 18 | FOCUS+ | | | Positive output pin to focus motor |
| 20 | SLED- | | | Negative output pin to sled motor |
| 21 | SLED+ | | | Positive output pin to sled motor |
| 22 | SP- | | | Negative output pin to spindle motor |
| 23 | SP+ | | | Positive output pin to spindle motor |
| 24 | EMP | | | — |
| 25 | RESET | Vcc1 | | Reset output pin |

| Pin No. | Symbol | Pin Voltage | Equivalent circuit | Description |
|---------|--------|-------------|--------------------|---------------------------------------|
| 26 | OFF | Vcc1 | | Input pin to put IC into standby mode |
| 27 | PWMFIL | — | | PWM filter pin |
| 29 | PSW | — | | PWM switching output pin |

| Pin No. | Symbol | Pin Voltage | Equivalent circuit | Description |
|---------|--------------------|-------------|--------------------|---|
| 30 | START | Batt | | Input pin to start the IC |
| 31 | KEY IN | — | | Input pin from wired remote to start the IC |
| 32 | REMO BATT | — | | Power supply to the built-in wired remote interface circuit |
| 33 | DC IN | 0 V | | Input pin to start the IC when AC adapter is inserted |
| 34 | GND | 0 V | | Ground |
| 35 | ISET | 1.2 V | | Set charging current of built-in battery charger |
| 36 | CHGV _{cc} | 4.5 V | | Power supply input to the battery charger |

| Pin No. | Symbol | Pin Voltage | Equivalent circuit | Description |
|---------|--------|-------------|--------------------|---|
| 37 | SEL | — | | Detection input pin for battery or AC adapter operation and Battery charging current output pin |
| 38 | BSEN | Batt | | Detection input pin for battery empty detection |
| 39 | BATT | 2.4 V | | Battery input pin |
| 40 | SW | — | | DC to DC controller output pulses |

| Pin No. | Symbol | Pin Voltage | Equivalent circuit | Description |
|---------|--------|-------------|--------------------|-------------------------------|
| 41 | DEAD | 0.88 V | | Soft start pin |
| 42 | EO | — | | Output pin of error amplifier |
| 43 | EI | 1.2 V | | Input pin of error amplifier |
| 44 | SPRT | 0 V | | Short protection pin |

| Pin No. | Symbol | Pin Voltage | Equivalent circuit | Description |
|---------|--------|-------------|--------------------|--|
| 45 | TR | 1.2 V | | Together with the capacitor at TC, set the start-up and free running frequency of sawtooth |
| 46 | TC | — | | Together with the resistor at TR, set the start-up and free running frequency of sawtooth |
| 47 | CLK | — | | Synchronizing clock pulse input |

Electrical Specifications

If not specified, Ta=25 °C, Batt=2.4 V, Vcc1=Vcc2=3.2 V, Vref=1.6 V, ChgVcc=0 V, fCLK=88.2 kHz

| Item | Symbol | Min. | Typ. | Max. | Unit | Condition | |
|-----------------------------|-----------|-------------|------|------|------|------------------------------------|---------------------------------|
| 1. Overall | | | | | | | |
| Batt standby current | IST | — | 0 | 2 | μA | Batt=9 V, Vcc1=Vcc2=0 V | |
| Batt quiescent current | IBAT | — | 2 | 3.2 | mA | PVcc=PWM, FT Mute=3.2 V | |
| Vcc1 quiescent current | IVcc1 | — | 4.9 | 6.7 | mA | PVcc=0.45 V, FT Mute=3.2 V, EI=0 V | |
| Vcc2 quiescent current | IVcc2 | — | 4.2 | 6.4 | mA | PVcc=0.45 V, FT Mute=3.2 V | |
| ChgVcc quiescent current | IChgVcc | — | 0.79 | 1.2 | mA | ChgVcc=4.5 V, Rch=open | |
| 2. H-Bridge driver | | | | | | | |
| Voltage gain | Spindle | Gv (sp) | 21.9 | 23.9 | 25.9 | dB | |
| | Sled | Gv (sled) | 14 | 15.5 | 17 | dB | |
| | Focus | Gv (focus) | 14 | 15.5 | 17 | dB | |
| | Track | Gv (track) | 14 | 15.5 | 17 | dB | |
| Gain difference | ΔGv | -2 | 0 | 2 | dB | | |
| Input impedance | Spindle | Rin (sp) | 5.7 | 7.5 | 11 | kΩ | IN*=1.7 and 1.8 V |
| | Sled | Rin (sled) | 8.8 | 11 | 15 | kΩ | |
| | Focus | Rin (focus) | 8.8 | 11 | 15 | kΩ | |
| | Track | Rin (track) | 8.8 | 11 | 15 | kΩ | |
| Maximum output voltage | Spindle | Vom (sp) | 1.9 | 2.1 | — | V | IN=0 and 3.2 V, PVcc=4 V |
| | Sled | Vom (sl) | 1.9 | 2.05 | — | V | |
| | Focus | Vom (foc) | 1.9 | 2.05 | — | V | |
| | Track | Vom (tra) | 1.9 | 2.05 | — | V | |
| Upper Tr saturation voltage | Spindle | VSAT (sp) | — | 280 | 400 | mV | Io=400 mA, SP IN=0 and 3.2 V |
| | Sled | VSAT (sl) | — | 280 | 400 | mV | Io=300 mA, SLED IN=0 and 3.2 V |
| | Focus | VSAT (foc) | — | 230 | 400 | mV | Io=200 mA, FOCUS IN=0 and 3.2 V |
| | Track | VSAT (tra) | — | 230 | 400 | mV | Io=200 mA, TRACK IN=0 and 3.2 V |
| Lower Tr saturation voltage | Spindle | VSATL (sp) | — | 230 | 400 | mV | Io=400 mA, SP IN=0 and 3.2 V |
| | Sled | VSATL (sl) | — | 250 | 400 | mV | Io=300 mA, SLED IN=0 and 3.2 V |
| | Focus | VSATL (foc) | — | 200 | 400 | mV | Io=200 mA, FOCUS IN=0 and 3.2 V |
| | Track | VSATL (tra) | — | 200 | 400 | mV | Io=200 mA, TRACK IN=0 and 3.2 V |
| Input offset voltage | VOI | -5 | 0 | 5 | mV | | |
| Output offset voltage | Spindle | VOO (sp) | -50 | 0 | 50 | mV | Vref=IN=1.6 V |
| | Sled | VOO (sled) | | | | | |
| | Focus | VOO (focus) | | | | | |
| | Track | VOO (track) | | | | | |
| Dead band | Spindle | VDB (sp) | -5 | 20 | 45 | mV | |
| | Sled | VDB (sled) | -10 | 15 | 40 | mV | |
| | Focus | VDB (focus) | -10 | 15 | 40 | mV | |
| | Track | VDB (track) | -10 | 15 | 40 | mV | SP IN=1.8V |
| Spindle mute on | VMSP(on) | 2 | — | — | V | SP IN=1.8V | |
| Spindle mute off | VMSP(off) | — | — | 0.8 | V | SLED IN=1.8V | |
| Sled brake on | VBSL(on) | 2 | — | — | V | SLED IN=1.8V | |
| Sled brake off | VBSL(off) | — | — | 0.8 | V | | |

* IN means SP IN, SLED IN, FOCUS IN or TRACK IN.

| Item | Symbol | Min. | Typ. | Max. | Unit | Condition |
|---|-----------------|--------|------|--------|------|--|
| Focus/Track mute on | VMFT (on) | — | — | 0.8 | V | FOCUS IN=1.8 V |
| Focus/Track mute off | VMFT (off) | 2 | — | — | V | FOCUS IN=1.8 V |
| Vref on voltage | Vref (on) | 1.2 | — | — | V | SP IN=1.8 V |
| Vref off voltage | Vref (off) | — | — | 0.8 | V | SP IN=1.8 V |
| 3. PWM driver for PVcc | | | | | | |
| PSW output current | IPSW | 10 | 13 | 17 | mA | SLED IN=2.1 V |
| PVCC shift voltage | VSHIF | 0.2 | 0.3 | 0.4 | V | SLED IN=1.8 V, PVcc-SLED+ |
| PVCC leakage current | IPVcc (leakage) | — | 0 | 3 | μA | PVcc=9 V, Vcc1=Vcc2=Batt=0 V |
| PWM transconductance | GPWM | 1/67.5 | 1/50 | 1/32.5 | 1/kΩ | SL IN=1.8 V, PVcc=1.2 to 1.4 V |
| 4. DC to DC converter | | | | | | |
| 4.1 Error amplifier | | | | | | |
| VCC1 threshold voltage | VCC1TH | 3.05 | 3.2 | 3.37 | V | |
| Hi error output voltage | VEOH | 1.5 | 1.65 | — | V | EI=0.7 V, Io=-100 μA |
| Lo error output voltage | VEOL | — | — | 0.2 | V | EI=1.36 V, Io=100 μA |
| 4.2 Short circuit and Over voltage protection | | | | | | |
| SPRT voltage (normal) | VSPR | — | 0.05 | 0.1 | V | EI=1.36 V |
| SPRT output current (EO=H) | ISPR1 | 6 | 10 | 16 | μA | EI=0.7 V, VSPR=0 V |
| SPRT output current (OFF=L) | ISPR2 | 12 | 20 | 32 | μA | EI=1.36 V, OFF=0 V, VSPR=0 V |
| SPRT output current (Over-voltage) | ISPR3 | 12 | 20 | 32 | μA | EI=1.36 V, Batt=9.5 V, VSPR=0 V |
| SPRT impedance | RSPR | 154 | 220 | 297 | kΩ | |
| SPRT threshold voltage | VSPR (Th) | 1.1 | 1.23 | 1.36 | V | EI=0.7 V, TC=0 V |
| Over voltage protect threshold | VBSEN (Th) | 8 | 8.4 | 9 | V | BSEN Voltage |
| 4.3 Sawtooth waveform | | | | | | |
| SW high output voltage (Starting) | VSWH (start) | 0.78 | 0.98 | 1.13 | V | Batt=TC=1.5 V, Vcc1=Vcc2=0 V, Io=-2 mA, START=LO |
| SW high output voltage (Normal) | VSWH (nor) | 1 | 1.5 | — | V | TC=0 V, Io=-10 mA, EI=0.7 V, SPRT=0 V |
| SW low output voltage | VSWL (nor) | — | 0.1 | 0.4 | V | TC=2 V, Io=10 mA |
| SW start freq | fsw1 | 55 | 85 | 115 | kHz | TC=420 pF, Vcc1=Vcc2=0 V, START=LO |
| SW free running freq | fsw2 | 60 | 70 | 82 | kHz | TC=420 pF, CLK=0 V |
| SW synchronized freq | fsw3 | — | 88.2 | — | kHz | TC=420 pF, CLK=88.2 kHz |
| Start freq duty cycle | DSW1 | 45 | 55 | 65 | % | TC=420 pF, Vcc1=Vcc2=0 V |
| Free freq duty cycle | DSW2 | 70 | 80 | 90 | % | TC=420 pF, EI=0.7 V, CLK=0 V |
| Synchronized freq duty cycle | DSW3 | 65 | 75 | 85 | % | TC=420 pF, EI=0.7 V |
| 4.4 Soft start | | | | | | |
| DEAD pin impedance | RDEAD | 55 | 80 | 105 | kΩ | |
| DEAD pin voltage | VDEAD | 0.72 | 0.82 | 0.92 | V | |

| Item | Symbol | Min. | Typ. | Max. | Unit | Condition |
|--------------------------------------|-----------------------|-------------------|------|-------------------|------|--|
| 4.5 Input | | | | | | |
| OFF threshold voltage | V _{OFF} (th) | — | — | V _{CC-2} | V | EI=1.36 V |
| OFF current | I _{OFF} | 55 | 80 | 105 | μA | OFF=0 V |
| START on threshold voltage | V _{START1} | — | — | Batt-1 | V | V _{CC1} =V _{CC2} =0 V, TC=2 V |
| START off threshold voltage | V _{START2} | Batt-0.3 | — | — | V | V _{CC1} =V _{CC2} =0 V, TC=2 V |
| START pin current | I _{START} | 9 | 14 | 19 | μA | START=0 V |
| Clock input voltage | High | V _{CLKH} | 2 | — | — | V |
| | Low | V _{CLKL} | — | — | 0.8 | V |
| Clock current | I _{CLK} | — | 5 | 10 | μA | CLK=3.2 V |
| 4.6 Start | | | | | | |
| Start cut threshold voltage | V _{ST} (th) | 2.3 | 2.5 | 2.7 | V | V _{CC1} =V _{CC2} =0 V→3.2 V, START=0 V |
| Start cut hysteresis | V _{ST} (hs) | — | 200 | — | mV | START=0 V |
| Discharge threshold voltage | V _{DIS} | 1.25 | 1.45 | 1.65 | V | |
| 5. EMPTY | | | | | | |
| Empty detect threshold 1 | V _{EMPT1} | 1.9 | 2.0 | 2.1 | V | V _{SEL} =0 V (SEL=LOW) |
| Empty detect threshold 2 | V _{EMPT2} | 1.5 | 1.6 | 1.7 | V | I _{SEL} =-2 μA (SEL=HI Z) |
| Empty detect hysteresis | V _{EMPH1} | — | 50 | — | mV | V _{SEL} =0 V (SEL=LOW) |
| Empty detect hysteresis | V _{EMPH2} | — | 50 | — | mV | I _{SEL} =-2 μA (SEL=HI Z) |
| EMPTY pin voltage | V _{EMP} | — | — | 0.5 | V | I _o =1 mA, B _{SEN} =1 V |
| EMPTY pin leakage current | I _{EMPL} | — | — | 1 | μA | B _{SEN} =2.4 V |
| B _{SEN} pin impedance | R _{BSEN} | 16.5 | 22.8 | 29 | kΩ | V _{SEL} =0 V |
| B _{SEN} pin leakage current | I _{BSEN} L | — | — | 1 | μA | V _{CC1} =V _{CC2} =0 V, B _{SEN} =4.5 V |
| SEL pin threshold voltage | V _{SEL} (th) | 1.3 | — | — | V | V _{SEL} (th)=Batt-SEL, B _{SEN} =2 V |
| SEL pin threshold current | I _{SEL} (th) | -2 | — | — | μA | |
| 6. RESET | | | | | | |
| Reset threshold voltage | V _{RST} (th) | 85 | 90 | 95 | % | |
| Reset hysteresis | V _{RST} (hy) | — | 50 | — | mV | |
| RESET pin | V _{RST} | — | — | 0.4 | V | I _o =1 mA, V _{CC1} =V _{CC2} =2.8 V |
| RESET pin impedance | R _{RST} | 66 | 88 | 118 | kΩ | |
| 7. OP AMP | | | | | | |
| Input bias current | I _{BIAS} | — | — | 250 | nA | OP+=1.6 V |
| Input offset voltage | V _{IO} | -5 | 0 | 5 | mV | |
| High output voltage | V _{OH} | 2.9 | — | — | V | R _L =open |
| Low output voltage | V _{OL} | — | — | 0.2 | V | R _L =open |
| Output current (Source) | I _{SOU} | — | -8.5 | -3 | mA | R _L =50 Ω to GND |
| Output current (Sink) | I _{SIN} | 0.4 | 0.8 | — | mA | R _L =50 Ω to V _{CC1} |
| Open loop gain | G _{VO} | — | 70 | — | dB | V _{in} =-75 dB, f=1 kHz |
| Slew rate | SR | 0.5 | 1 | 1.5 | V/μS | |

| Item | Symbol | Min. | Typ. | Max. | Unit | Condition |
|---|-------------|------|------|------|------------|---|
| 8. BATTERY CHARGER | | | | | | |
| RCHG pin voltage | VRCHG | 0.7 | 0.8 | 0.9 | V | ChgVcc=4.5 V, ISET=1.8 k Ω |
| RCHG pin impedance | RRCHG | 0.68 | 0.96 | 1.16 | k Ω | ChgVcc=4.5 V, ISET=0.5 and 0.6 V |
| SEL pin leakage current (RCHG=open) | ISEL1 | — | — | 1 | μ A | ChgVcc=4.5 V, ISET=open |
| SEL pin leakage current (ChgVcc=0.6 V) | ISEL2 | — | — | 1 | μ A | ChgVcc=0.6 V, ISET=1.8 k Ω |
| SEL pin voltage | VSEL | — | 0.45 | 1 | V | ChgVcc=4.5 V, Io=300 mA, ISET=0 Ω |
| 9. WIRED REMOTE INTERFACE | | | | | | |
| DC IN pin threshold voltage | VDCIN (th) | 1 | — | — | V | Batt=4 V, Vcc1=Vcc2=0 V, TC=2 V, DC=IN=from 0 to 3 V |
| KEY IN pin threshold current | IKEYIN (th) | — | — | 5 | μ A | Batt=4 V, Vcc1=Vcc2=0 V, TC=2 V, IKEYIN=from 0 to 10 μ A |

Electrical Characteristics Test Circuit

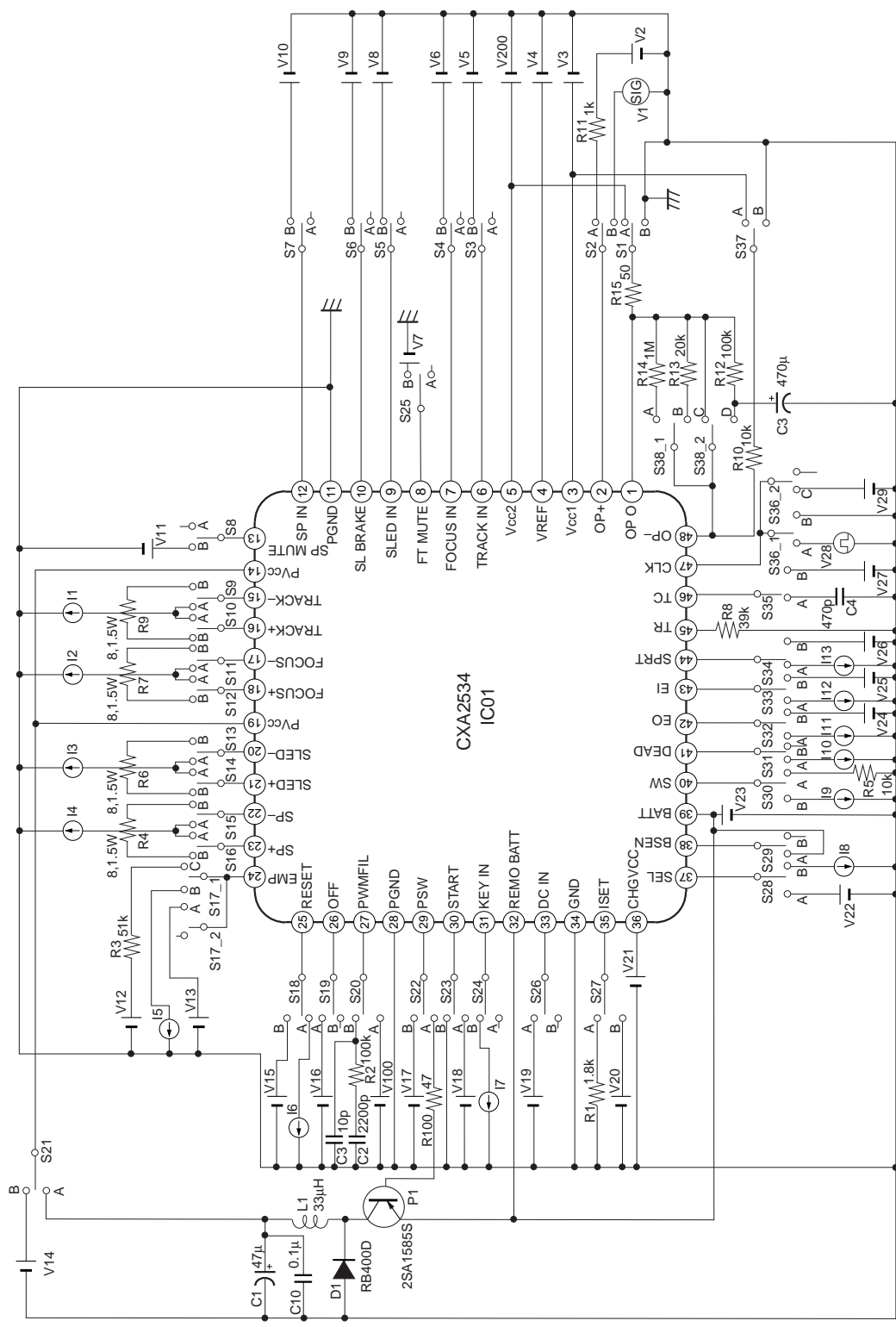

Application Circuit

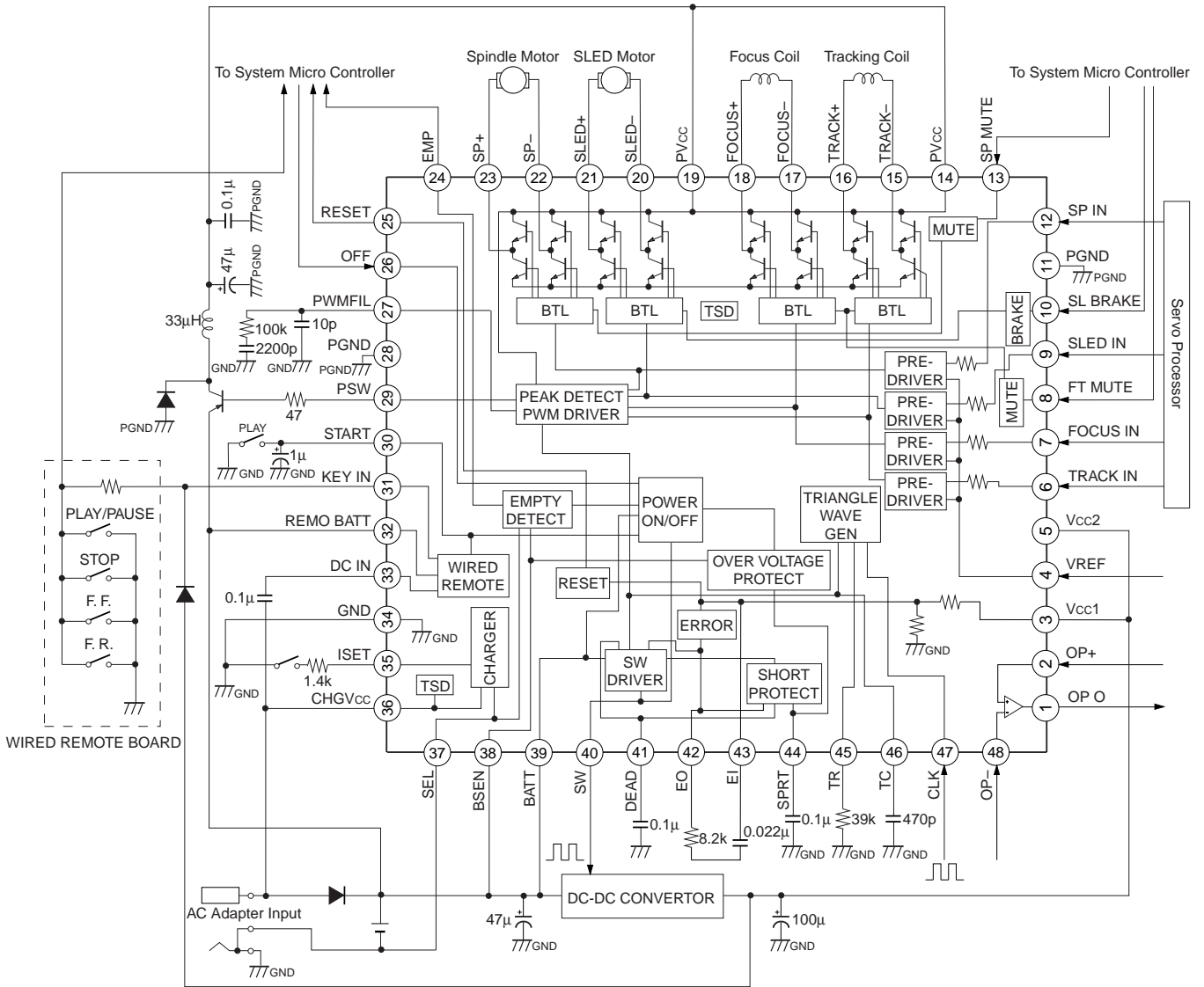

Application circuits shown are typical examples illustrating the operation of the devices. Sony cannot assume responsibility for any problems arising out of the use of these circuits or for any infringement of third party patent and other right due to same.

Description of Operation

1. H-Bridge Driver

a) Gain Setting

The input resistances of the Sled, Focus and Track channels are 11 kΩ (typical); the input resistance of the Spindle channel is 7.5 kΩ (typical). The gain can be adjusted by connecting an external resistor, R at the input pin of the channel.

| Channel | | Unit |
|--|--|------|
| Sled channel Focus channel Track channel | $G_v = 20 \log \left \frac{55 \text{ k}\Omega}{11 \text{ k}\Omega + R} \right $ | dB |
| Spindle channel | $G_v = 20 \log \left \frac{110 \text{ k}\Omega}{7.5 \text{ k}\Omega + R} \right $ | dB |

R - External Resistor

b) Mute

The Spindle channel operates normally when the SP MUTE (pin 13) is open or at LOW (below 0.8 V). The output will be muted when the SP MUTE pin is at HIGH (above 2 V). This is a high impedance mute as the spindle output voltage will be not pulled to LOW.

The Focus and Track channels share the same mute pin (pin 8). The channels are muted when the FT MUTE pin (pin 8) is open or at LOW level (below 0.8 V). When the Focus and Track channels are muted, the quiescent current at the Vcc2 pin is also reduced by almost half. This is because the bias are removed when the mute is on.

c) Thermal Shutdown

The H-bridge Driver has an internal thermal shutdown circuit. All the channels outputs will be muted when the chip temperature exceeds 170 °C (typical) and restored when the chip temperature falls to 140 °C (typical).

d) VREF pin

When the VREF pin (pin 4) is below 1 V (typical), the H-bridge driver will be at standby mode and the quiescent current is zero (typical).

e) Dead Band

$$\text{Dead band} = 2 \times \text{input Resistance (attached external resistor + internal resistor)} \times 0.5 \mu\text{A}$$

The dead band is depended on input resistance. Thus, the dead band varies with the gain settings. The dead band is 7.5 mV for Spindle channel and 11 mV for Sled, Focus and Track channels.

f) PWM Driver For PVcc

To ensure the good power efficiency of the H-bridge driver, a Buck DC-to-DC converter may be used to regulate the PVcc. The controller selects the peak voltage among the channels and used it to control the duty cycle of the PWM. External components necessary are: PNP transistor, inductor coil, diode and capacitors. The configuration of a Buck DC-to-DC converter is shown as follow:

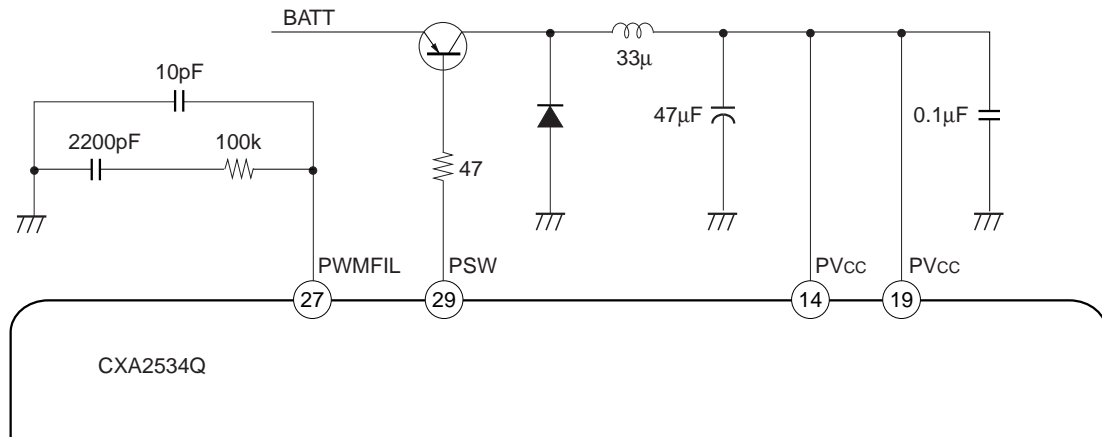

g) Bypass Capacitor

To have prevent noise, a bypass capacitor (roughly 0.1 μF) is connected from PVcc pin to the GND pin as close as possible.

2. DC-to-DC Converter

a) Vcc1 Voltage Setting

The Vcc1 voltage can be adjusted by varying the two external resistors, R1 and R2. The formula for Vcc1 Voltage setting is:

$$V_{cc1} = 1.23 \frac{\frac{R_1 R_3}{R_1 + R_3} + \frac{R_2 R_4}{R_2 + R_4}}{\frac{R_2 R_4}{R_2 + R_4}} \quad (V)$$

- where R1 - External Resistor
- R2 - External Resistor
- R3 - 35 kΩ
- R4 - 21 kΩ

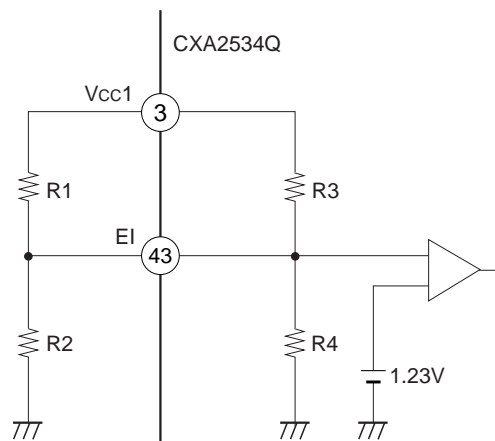

b) Short Circuit Protection

If the Vcc1 falls below the designed voltage for a long time, it will be considered as a short circuit at the Vcc1. In this case, the IC will detect this prolong drop in Vcc1 and turn off the IC.

When the Vcc1 is below the designed voltage, the error amplifier will output an HIGH at its EO pin (pin 42). The High level at EO pin will cause the SPRT pin's capacitor (pin 44) to charge up by a constant current of 10 μA. Once the voltage is above 1.23 V (typical), the IC will turn off. The duration of the short circuit can be varied by the SPRT pin's capacitor.

$$t = \frac{1.23V}{10\mu A} \times C_{SPRT} \quad (\text{sec})$$

c) Soft Start

During start-up of the IC, the duty cycle of the DC-to-DC converter is increased slowly to a maximum of 80 %. The Vcc1 voltage will also increase slowly. This is known as soft start.

During the soft start, the duty cycle of the SW pin (pin 40) is dependent on the voltage at the DEAD pin (pin 41). The DEAD pin is connected to a capacitor which is being charged up by an internal resistance of 65 kΩ. Therefore, the time taken for the duty cycle to reach the maximum is

$$t = C_{SPRT} \times R \quad (\text{sec}) \quad \text{where } R = 65 \text{ k}\Omega$$

d) Power Off

To turn off the DC-to-DC Converter, a LOW level is applied to the OFF pin (pin 26). When the OFF pin is low, the IC will not turn off the DC-to-DC converter immediately but will charge up the SPRT pin's capacitor with a constant current of 20 μA. Once the SPRT pin's voltage is above 1.23 V, the IC will then shut down. Therefore, the delay is given by the formula below:

$$t = \frac{1.23 \text{ V}}{20 \mu\text{A}} \times C_{SPRT} \quad (\text{sec})$$

e) Over-Voltage Protection

The IC will detect a over-voltage if the voltage at the BSEN pin is above 8.4 V (typical). When over-voltage occurred, the IC will shut down after a time delay. The time delay is determined by the time taken for the SPRT pin's capacitor to charge above 1.23 V. The charging current for the SPRT pin capacitor is constant and is 20 μA.

$$t = \frac{1.23 \text{ V}}{20 \mu\text{A}} \times C_{SPRT} \quad (\text{sec})$$

f) Reset Pulse

When the Vcc1 voltage rises above 90 % of the designed value, the RESET pin (pin 25) will change from LOW level to HIGH level. A hysteresis of 50 mV (typical) is implemented to prevent the 'chattering' of the output at RESET pin.

g) Empty Detection

The EMP pin (pin 24) is used to indicate low battery voltage. When the BSEN pin falls below a certain threshold voltage, the EMP pin will change from HIGH to LOW level. There are two threshold voltages, depending on the SEL pin (pin 37). In order to prevent 'chattering' of the output at the EMP pin, a hysteresis of 50 mV (typical) is implemented.

| SEL pin | Threshold Voltage (typical) | Recovery Voltage (typical) |
|----------|-----------------------------|----------------------------|
| LOW | 2.0 V | 2.05 V |
| High - Z | 1.6 V | 1.65 V |

3. Battery Charger

The Battery Charger is separated from the rest of the circuit. The ChgVcc pin (pin 36) is the power supply pin to the charger circuit. The charging current is drawn in from the SEL pin (pin 37) and can be set by an external resistor at ISET pin (pin 35). The charger has a built-in thermal shut down circuit. The shut down temperature is set to 170 °C and 140 °C is the recovery temperature.

4. Wired Remote Interface

When the IC is at standby, it can be activated by pulling the START pin (pin 30) or the KEY IN pin (pin 31) LOW. The START pin is controlled by the PLAY button on the main set and the KEY IN pin is controlled by the PLAY button on the wired remote control panel.

The wired remote interface circuit is powered at REMO BATT pin (pin 32) which is connected to the BATT. To ensure that the voltage at REMO BATT pin is not greater than V_{cc1} , a resistor and zener diode ($V_z=3.1$ V) may be necessary.

The DC IN pin (pin 33) will detect a pulse through a series capacitor when a AC adapter is power on. This pulse will activate the IC also.

Package Outline Unit : mm

48PIN QFP (PLASTIC)

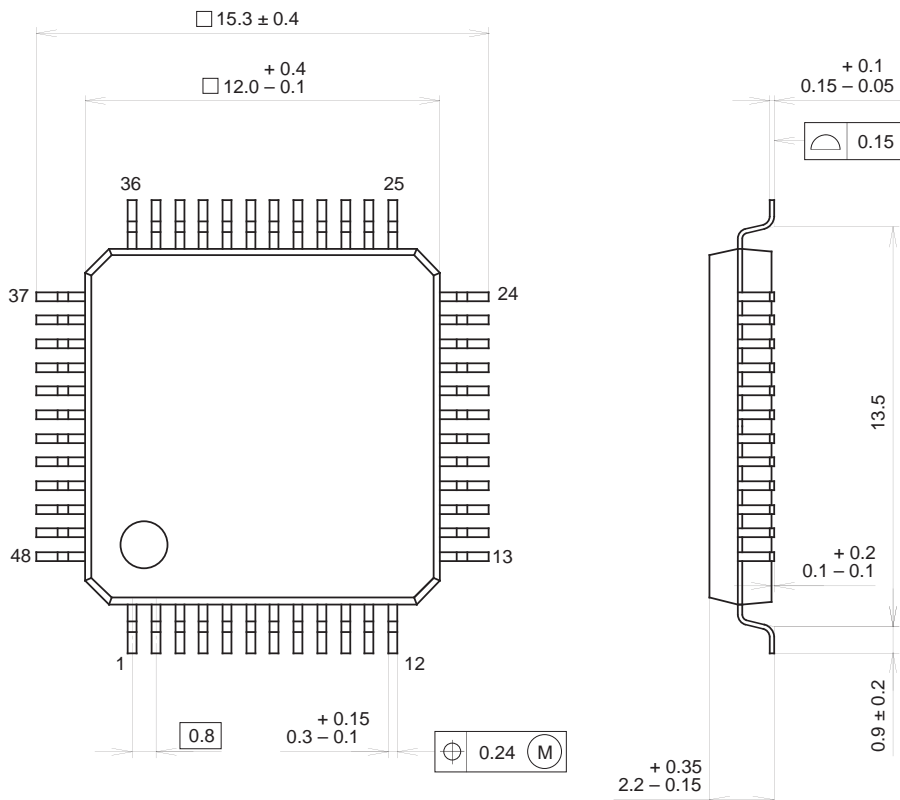

PACKAGE STRUCTURE

| | |
|------------|---------------|
| SONY CODE | QFP-48P-L04 |
| EIAJ CODE | QFP048-P-1212 |
| JEDEC CODE | — |

| | |
|------------------|----------------------------|
| PACKAGE MATERIAL | EPOXY RESIN |
| LEAD TREATMENT | SOLDER / PALLADIUM PLATING |
| LEAD MATERIAL | 42/COPPER ALLOY |
| PACKAGE MASS | 0.7g |

NOTE : PALLADIUM PLATING

This product uses S-Pd PPF (Sony Spec.-Palladium Pre-Plated Lead Frame).