

SONY

CXA3050M

NICAM and SMATV RF MODULATOR/PLL

Description

Fully synthesized I²C controlled UHF/VHF TV RF Modulator compatible with PAL and NTSC video formats.

Features

- Minimal adjustment of external components
- For use on VHF and UHF TV Frequencies
- Video RF carrier frequency programmable in 125kHz steps
- Accepts NICAM 6.552MHz QPSK input signal
- Accepts FM Stereo input signal
- I²C control of:
 - a. Video RF Carrier Frequency
 - b. Sound Carrier Frequency
 - c. Modulation Depth ($\pm 2\%$ Typ.)
 - d. FM Deviation ($\pm 8\%$ Typ.)
 - e. P/S ratio ($\pm 1\text{dB}$ Typ.)
 - f. Nicam output enable to sleep
 - g. Video RF carrier enable to sleep
- On chip Regulator 3.1V

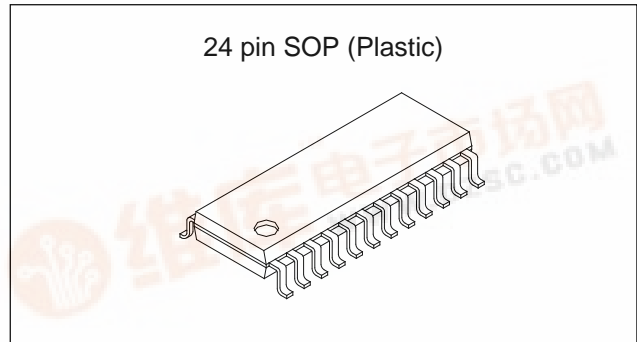

Structure

Bipolar silicon monolithic IC

Applications

- PAL and NTSC System VCR
- Satellite Receiver
- Set Top Box
- SMATV

Recommended Operating Voltages (Ta = 25°C)

- Supply voltage V_{cc} 5.0 \pm 0.5 V
- Supply for VCO Varactor 30 \pm 0.5 V
- Operating Temperature -10 to +80 °C

Block Diagram

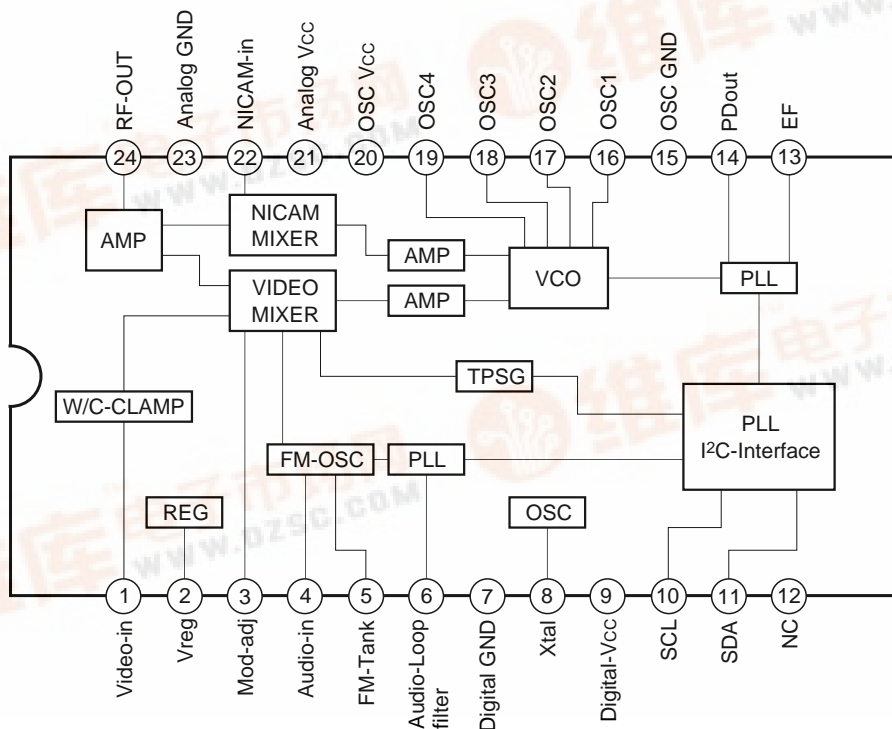

Multi-standard RF Modulator

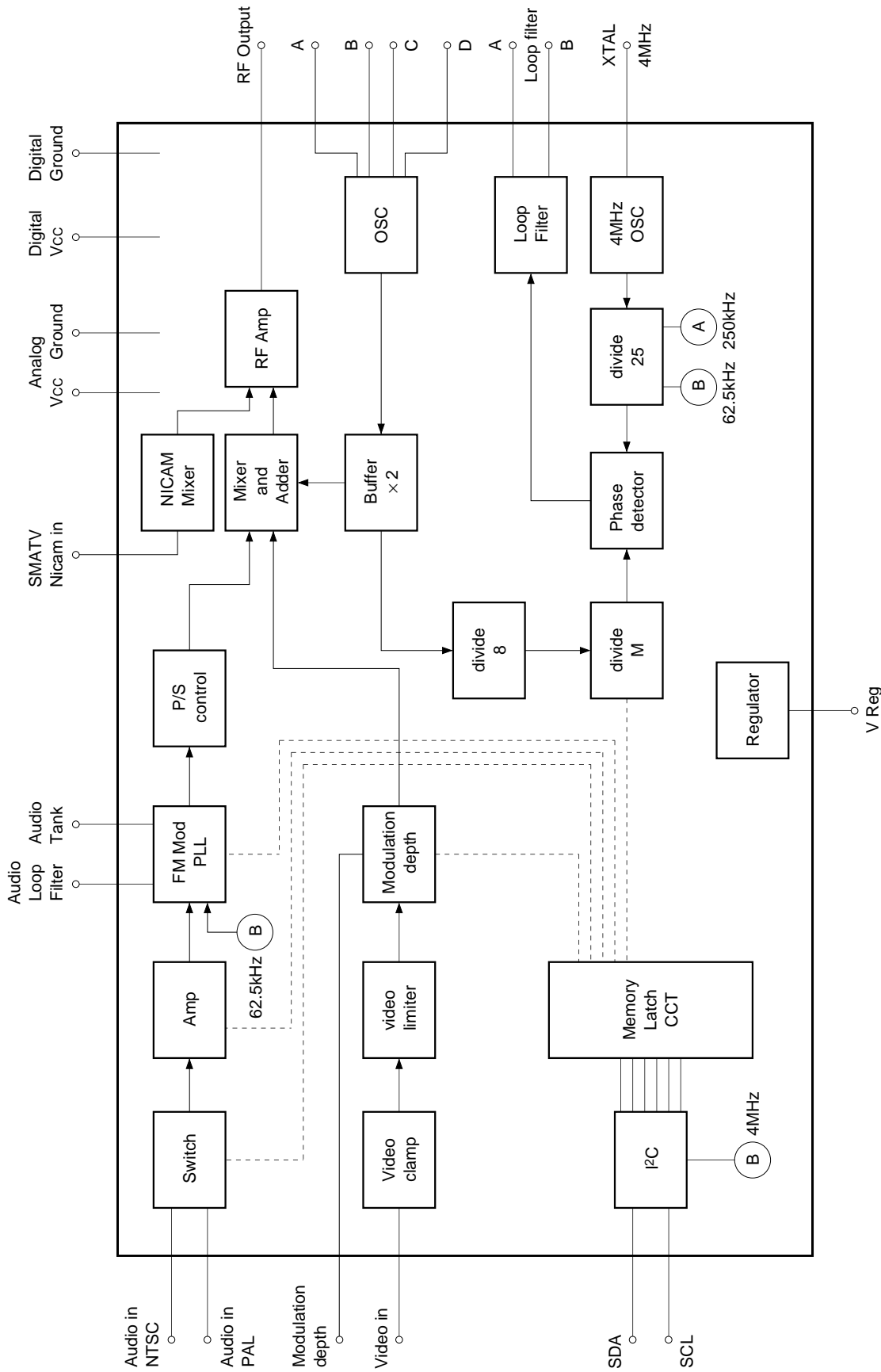

Fig. 1

Functional Description of RF Modulator System

A block diagram of the RF modulator is shown in Fig. 1.

The composite video signal passes through an amplitude limiting circuit and a digitally controlled modulation depth adjustment circuit. By means of three allocated I²C control bits it is possible to adjust the modulation depth from a nominal 74% to 86% in 2.0% steps. Modulation depth can also be controlled externally by addition of an external resistor on pin3. The video signal is then passed through to the mixer. In the mixer stage, both the video composite signal and FM sound carrier amplitude modulate the RF carrier from the UHF OSC, and the issuing signal is fed to the output via an RF amplifier.

The audio signals enter the chip via pin4. The FM Voltage Controlled Oscillator is band-switched to the approximate centre frequencies of the four sound carrier frequencies 4.5MHz (NTSC) or 5.5, 6.0, 6.5MHz (PAL). The required correct audio carrier frequency is fine tuned by the adjustment of f_{sound} via I²C, where upon the FM phase locked loop will lock the VCO onto the exact centre frequency. Minimum distortion of the FM signal occurs when the centre frequency of the oscillator coincides with a mid-rail control voltage (to 2.0V). Hence fine adjustment capacitors are also integrated on the chip, which tag into account any capacitance variations from one batch to another. This is achieved by fine adjustment of Delta f_{sound} via I²C control. The design of the FM modulator eliminates the need for an external varactor.

The amplitude of the FM signal is varied via I²C by a digitally controlled logarithmic gain stage, which controls the picture to sound power ratio (P/S). This signal is then fed into the RF amp. Hence at the RF output the P/S ratio can be programmed in 1dB steps between the range 10dB and 17dB (see Electrical Characteristics). Audio sensitivity can be programmed in 8% steps between the range -32% and +24%.

The UHF is phase locked to the reference frequency by means of the UHF phase locked loop. The VCO output passes through a prescaler (≈ 8) followed by an I²C controlled programmable divider ($\approx M$), and then phase compared with that of a reference signal at 15.625kHz. The reference signal is derived from a 4MHz crystal oscillator feeding a -256 divider. The UHF oscillator covers the frequency range 471MHz to 855MHz in frequency steps of 125kHz. This is adequate for the UHF NTSC and PAL TV channels (471.25MHz (CH21) to 855.25MHz (CH69)). By adjustment of the external components around the oscillator and some adjustment to output matching the RF modulator can also achieve range of frequencies in the VHF range.

The Nicam input (pin 22) accepts the 6.522MHz Nicam signal subcarrier QPSK at 728K bits/s data. This is then buffered and feed into a separate mixer (controlled via VCO). This then feeds to the RF amp with the composite video and audio. The I²C control will switch the Nicam signal output off or on.

I²C Interface Data Format

Modulator Address	1	1	0	0	1	0	0	R/W	ask
Data 1	PD	ADJ1	ADJ0	S1	S0	over mod	X	X	ask
Data 2	M12	M11	M10	M9	M8	M7	M6	M5	ask
Data 3	M4	M3	M2	M1	M0	MD2	MD1	MD0	ask
Data 4	X	NIC	FM2	FM1	FM0	PS2	PS1	PS0	ask

Sound Carrier Course Adjust

S1	S0	Sound Carrier Frequency	TV System (Pre-emphasis)
0	0	4.5MHz	NTSC
0	1	5.5MHz	PAL
1	0	6.0MHz	PAL
1	1	6.5MHz	PAL

Sound Carrier Fine Adjust

ADJ1	ADJ0	df Adjust	on chip capacitance
0	0	-f	6.4pF
0	1	Normal	3.2pF
1	0	+f	1.6pF
1	1	+f	0

- PD RF Power on (RF Amp & OSC) 1 bit
 - OVM Over Modulation Test 1 bit
 - M12–M0 Main divider control data 13 bits
 - S1–S0 Sound carrier frequency selection 2 bits
 - ADJ1–ADJ0 Sound carrier frequency adjust (0 to 6.4RF) 2 bits
 - MD2–MD0 Modulation Depth 3 bits
 - PS2–PS0 Picture/Sound control 3 bits
 - FM FM deviation adjust 3 bits
 - NIC Nicam Enable 1 bit
 - M12 MO Main UHF PLL Divider
 - MSB LSB 8191 to 2
- Video Carrier frequency calculated from = 125 (M + 2) kHz

Software Application Notes

The minimum requirement to drive the CXA3050 and I²C bus drive is a 386/486 with 4M bytes hard disk space, 16MHz clock speed and running DOS5.00 or above. Insert the disc into the drive and type TESTS and at the prompt type iic. At this there should appear a single list of user friendly functional tests that can be changed by keyboard manipulation. As an aid the test list is written below. Note Page up increments the status, page down decrements the status.

Function	Nominal Status	Comments
RF Output Power	1/0	Turns RF Amp, OSC on/off
Delta Sound	1	Fine tune audio carrier
Fsound	0	Course adjust for 4.5MHz (0) 5.5MHz (1) 6.0MHz (2) 6.5MHz (3)
Frequency mode	2 to 8191	Check listing on page 10 for frequency to hex conversation
Mod depth	4	Ranges mod depth from 72% to 86%, 80% (4)
FM Deviation	4	Sensitivity adjustable
P/S Ratio	4	Programmable in 8 steps of 1dB
Nicam on/off	1/0	Nicam Mixer on
Over Mod on/off	1/0	Increase Video modulation ratio

Pin Description

Pin No.	Reference	Pin Voltage Typical DC	Equivalent circuit	Description
1	Video-in	2.5V		Video input
2	Vreg	3.1V		Chip voltage supply regulator
3	Mod-Adj	2.5V		External Adjust Mod depth.
4	Audio-in	10mA		Audio input
5	FM-Tank	4.0V		Sound Carrier oscillator tank

Pin No.	Reference	Pin Voltage Typical DC	Equivalent circuit	Description
6	Audio-Loop filter	2.02V		Sound Carrier FM tank loop filter. See page 2 for set up note
8	Xtal	1.5V		4MHz input crystal frequency
10	SCL	5/0 V		I ² C Clocking signal input
11	SDA	5/0 V		I ² C Data signal input
13	EF	0.7V		Charge pump output

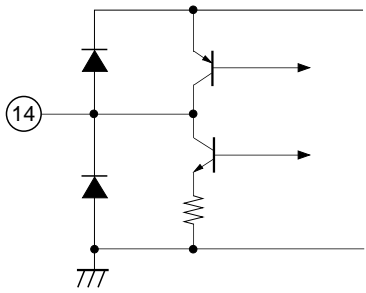
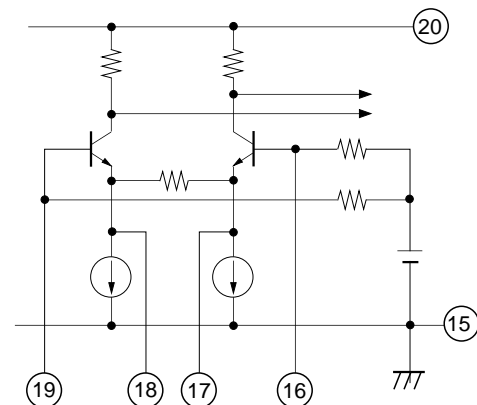
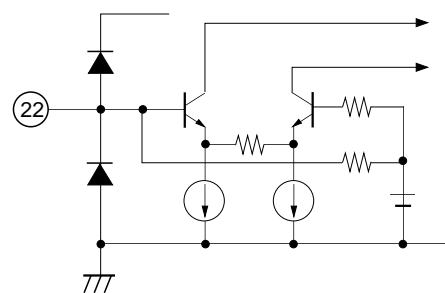
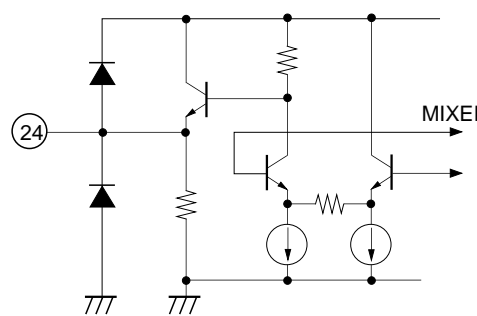
Pin No.	Reference	Pin Voltage Typical DC	Equivalent circuit	Description
14	PDout	2.1V		Phase detector output
15	OSC GND	0V		VCO Ground
16	OSC1	2.5V		UHF OSC
17	OSC2	1.7V		
18	OSC3	1.7V		
19	OSC4	2.5V		
20	OSC Vcc	5V		Oscillator supply Voltage 5V
22	Nicam-in	2V		NICAM or FM carrier input
24	RF-OUT	3.4V		RF output. Must be terminated with 75Ω.

Application Circuit Notes

- RF output pin 24 should be connected to a 75Ω load in order to measure accurate input level. Also note pin 24 has 2.7kΩ to GND.
The output is measured using a spectrum analyzer.
- After turning the device on, tune the variable inductor FM Tank so at the 6.5MHz setting (set by I²C control) the voltage on pin 6 should read 2.02V.
Set Fsound = 3
Delta Fsound = 1

Specifications

Parameter	New Specification
Operating temperature range	-10 to 80°C
Modulation Index	77.5 to 90%
Diff. Gain 80 to 87.5% modulation	±6.5%
Diff. Gain 80 to 87.5% modulation	±6.5 degree
Deviation range (audio)	±10kHz to ±100kHz
NICAM input level	79dBμV
NICAM input resistance	1kΩ
Picture/sound ratio adj	1dB × 7steps
Video modulation adj	2% × 7steps
Audio FM sensitivity	8% × 7steps
Picture/Sound ratio	1dB × 7steps
Inter carrier accuracy	±1kHz

Parameter	Condition	Min.	Typ.	Max.	Unit
Current consumption Full operation Vcc = 5.0V	Analog	40	50	61.3	mA
	digital	20	25	30.6	mA
	OSC	9.6	12	14.6	mA
DC Supply operating range		4.5	5.0	7	Vdc
Operating temperature range		-10		75	°C
Input level			79		dBμV
Output level	Conversion, Loss = 30dB	-20	-22	-24	dBc
Input resistance			1		KΩ
Bit error rate			10e ⁻⁹	10e ⁻⁶	
Eye-height degradation				10	%

RF Characteristics

Parameter	Condition	Min.	Typ.	Max.	Unit
Output impedance			75		Ω
Output return loss		-7			dB
RF Output level	700MHz 75 Ω termination		79	± 2.5	dB μ V
RF Frequency response	Using attached application			± 1	dB
Picture/Sound ratio		10		17	dBc
VHF1 Frequency range		50		120	MHz
VHF2 Frequency range		170		230	MHz
UHF Frequency range 1		470		860	MHz
UHF Frequency range 2	Using attached application	670		800	MHz
RF Accuracy				± 50	kHz
Inter-carrier frequency range	4.5, 5.5, 6.0, 6.5	4.5		6.5	MHz
Inter-carrier accuracy	4.5, 5.5, 6.0, 6.5	0		± 1	kHz
RF Carrier phase noise	10kHz offset frequency		-84.7	-80	dBc/Hz
Sound carrier phase noise	10kHz offset frequency		-84.7	-80	dBc/Hz
Hum modulation				-60	dB
Chroma beat			-78	-65	dBc
C/N Ratio	1/2 Video band offset		-63	-60	dB
RF Harmonics				-15	dBc
Sub-carrier harmonics				-60	dBc
NICAM Beat				-65	dBc
Reference spurious frequency.	15.625kHz		-60	-55	dBc
Spurious output level				-65	dBc

Video Characteristics

Parameter	Condition	Min.	Typ.	Max.	Unit
Input resistance		30	100		K Ω
Input voltage	80% Modulation		0.55		Vp-p
% Modulation Clipping				97	%
I ² C control index	7 steps		2	± 0.4	%
Modulation flatness	Band Limited (46CH to 60CH)			± 1.4	%
Modulation	0.55p-p input (mod Adja)	73	80	87	%
Modulation stability by temperature	mp (Ta = -10 to 80°C) -mp (Ta = 25°C)			± 3	%
Field time distortion		0	0.5	2	IRE
Line time distortion		0	0.5	2	IRE
S/N	Weighted			-60	dB
K Factor	With 2T pulse			2	%
Video frequency response	Per standard	0		± 0.5	dB

Audio Characteristics

Parameter	Condition	Min.	Typ.	Max.	Unit
Input voltage	@50kHz, Deviation	0.1			Vp-p
Input resistance		20			K Ω
Deviation range		± 10		± 100	kHz
Audio distribution	4.5MHz		0	± 15	%
Deviation sensitivity	System M 4.5MHz \pm 25kHz = 100% = 0dB		0.5		kHz/mV
	System B/G 5.5MHz \pm 50kHz = 100% = 0dB		0.33		kHz/mV
	System I 6MHz \pm 50kHz = 100% = 0dB		0.404		kHz/mV
	System D/K 6.5MHz \pm 50kHz = 100% = 0dB		0.404		kHz/mV
Audio SNR	Quasi-Parallel, Detection			-60	dB
Harmonic distortion	50 to 100%, Deviation			1	%
Frequency response	50 to 15kHz	-1		+1	dB
FM Hum and noise	25 to 75kHz, Deviation			± 5	kHz

Application Circuit 1

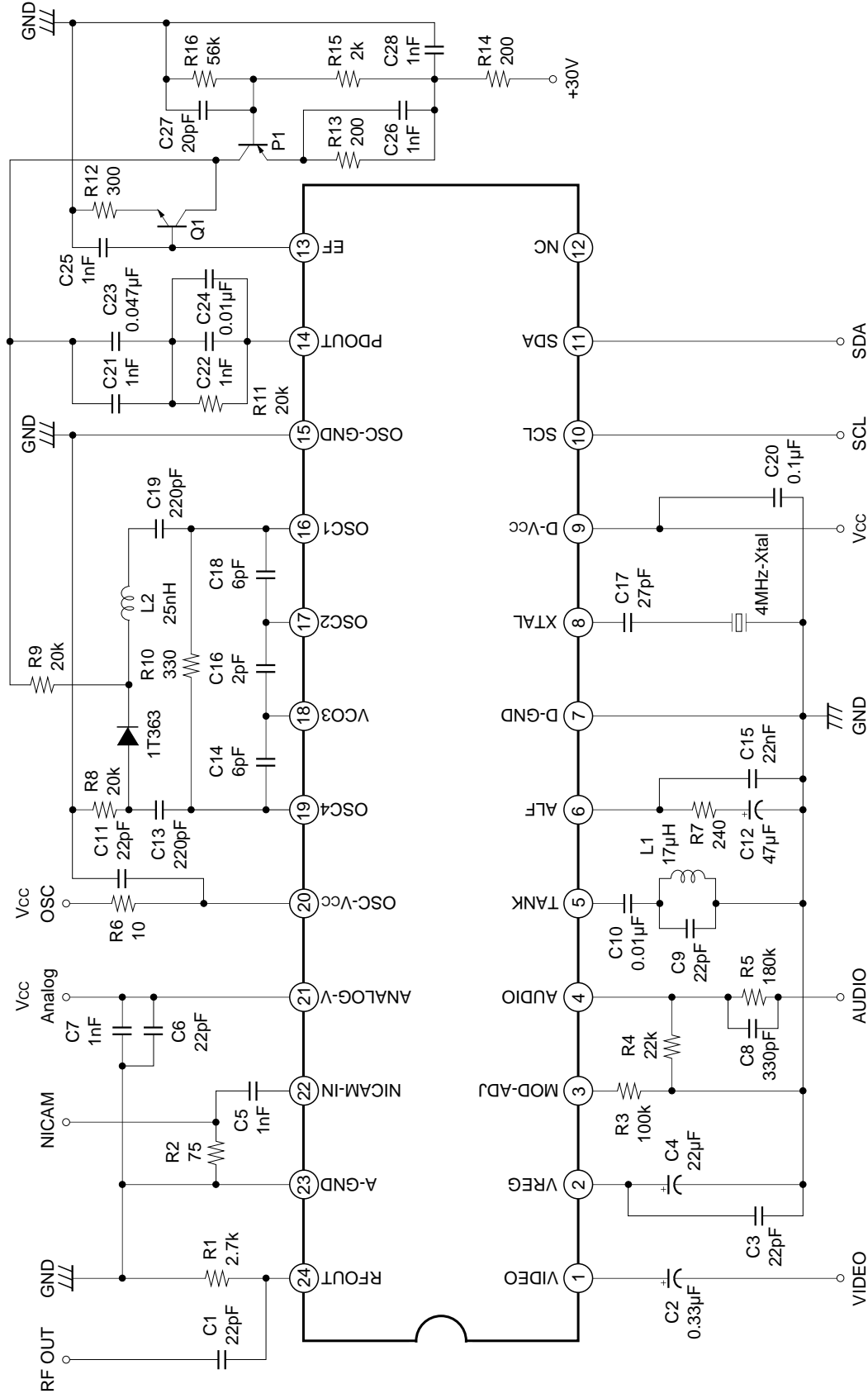

Application circuits shown are typical examples illustrating the operation of the devices. Sony cannot assume responsibility for any problems arising out of the use of these circuits or for any infringement of third party patent and other right due to same.

Application Circuit 2
Dual-OSC

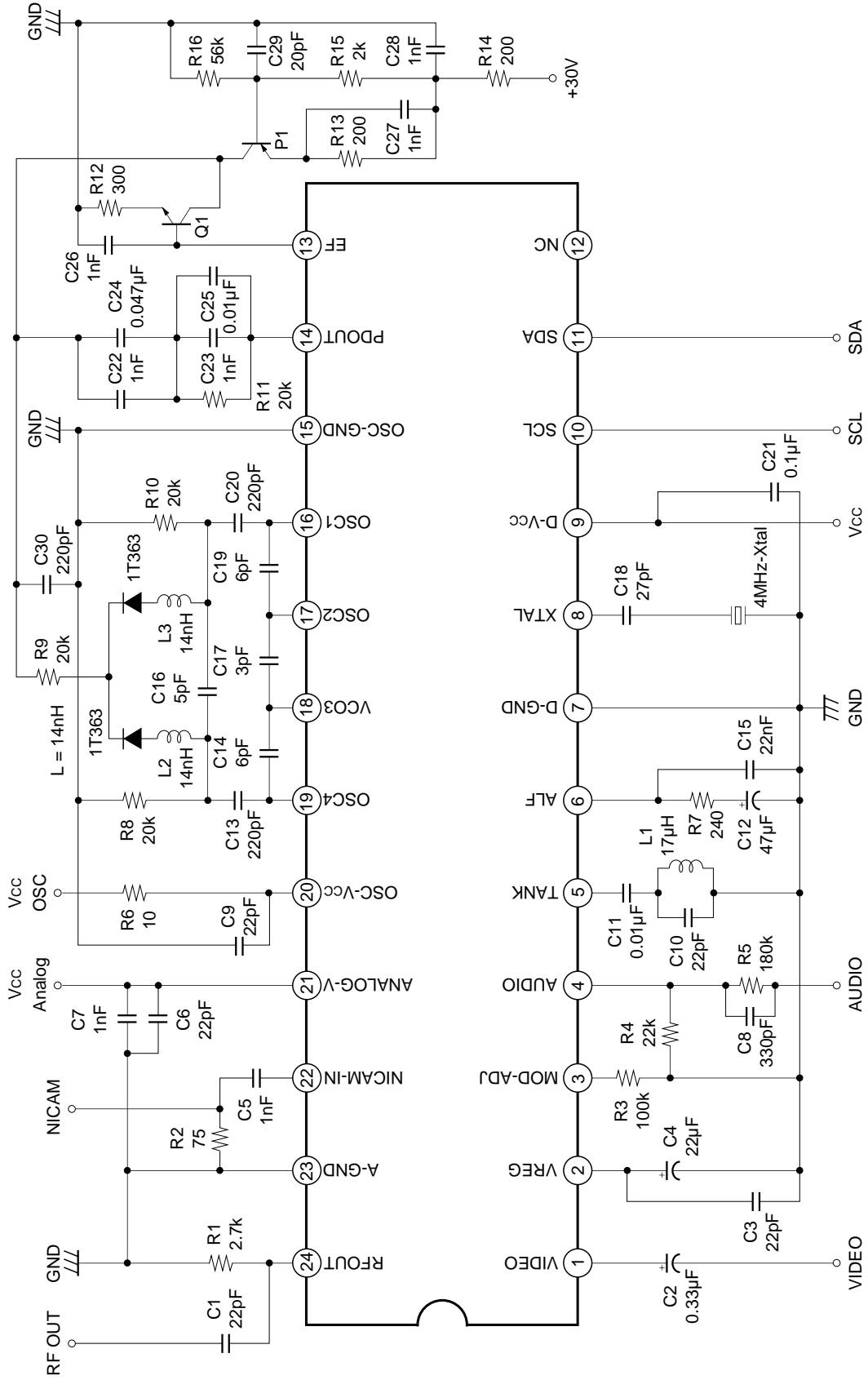

Application circuits shown are typical examples illustrating the operation of the devices. Sony cannot assume responsibility for any problems arising out of the use of these circuits or for any infringement of third party patent and other right due to same.

Application Circuit 3
VHF-Band

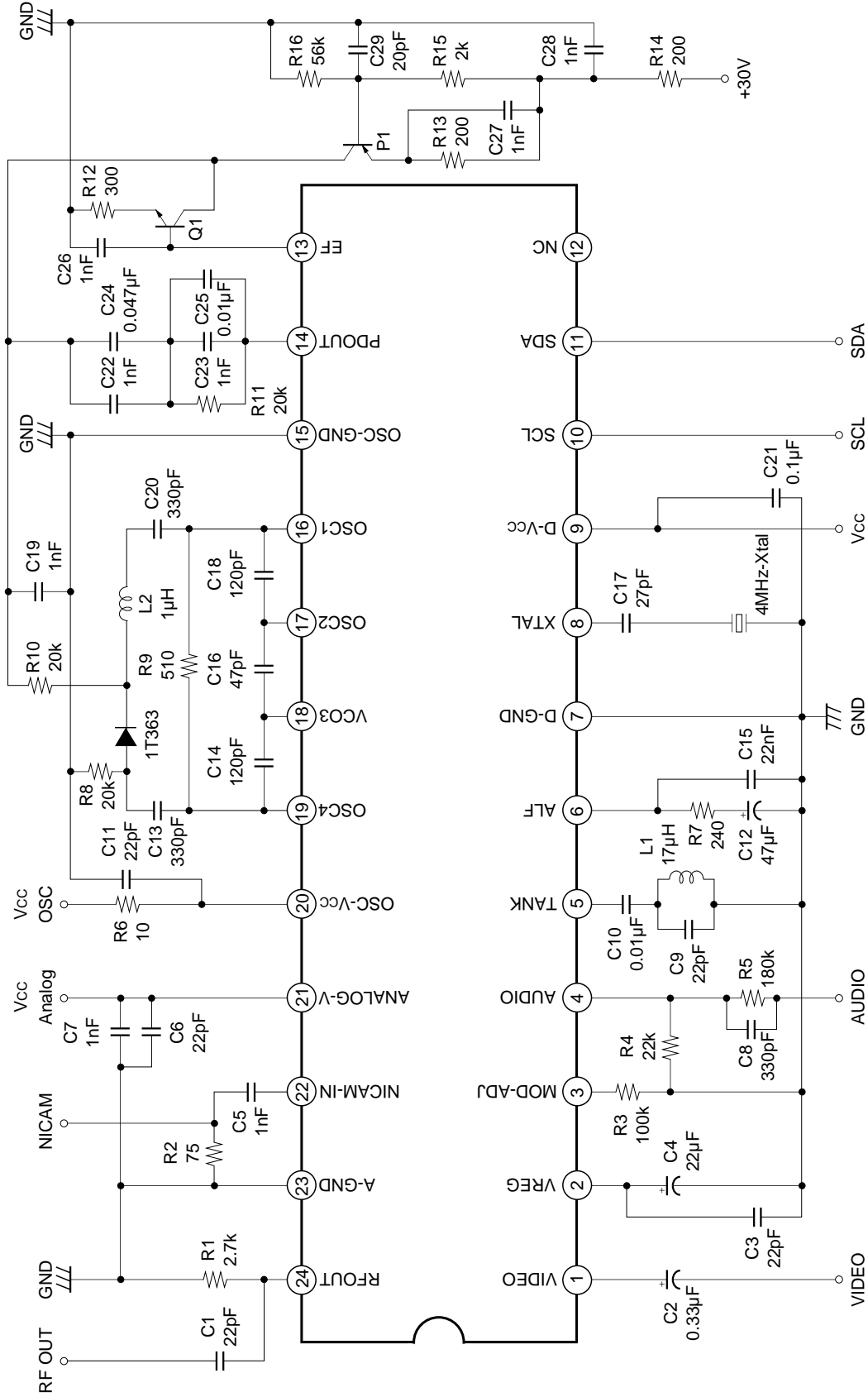

Application circuits shown are typical examples illustrating the operation of the devices. Sony cannot assume responsibility for any problems arising out of the use of these circuits or for any infringement of third party patent and other right due to same.

Example of Representative Characteristics

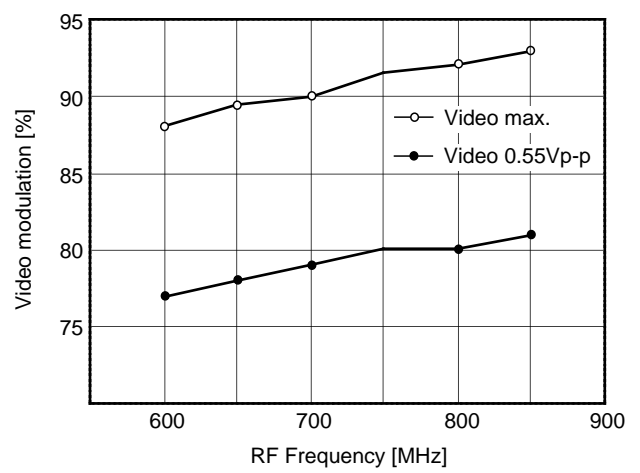
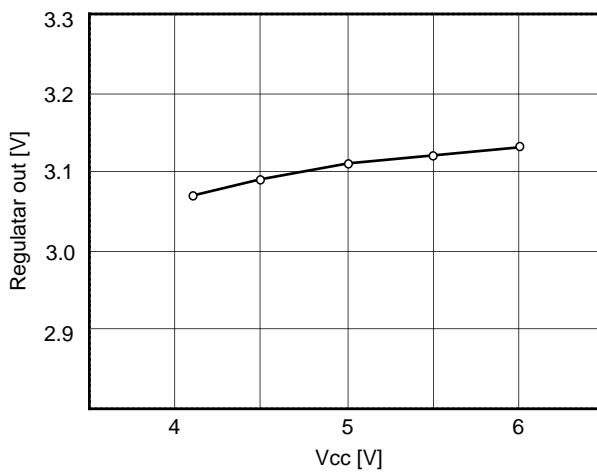
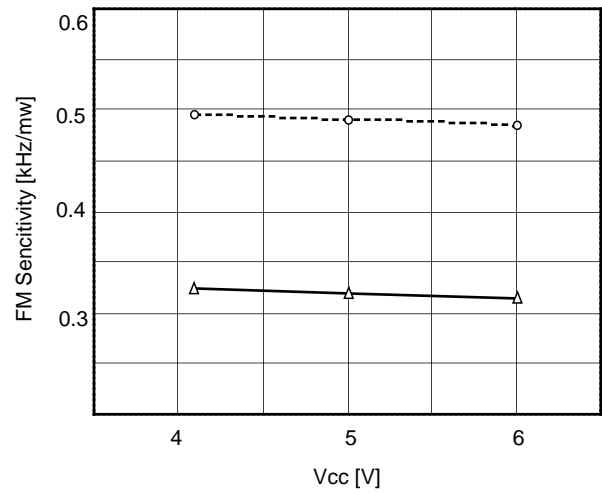
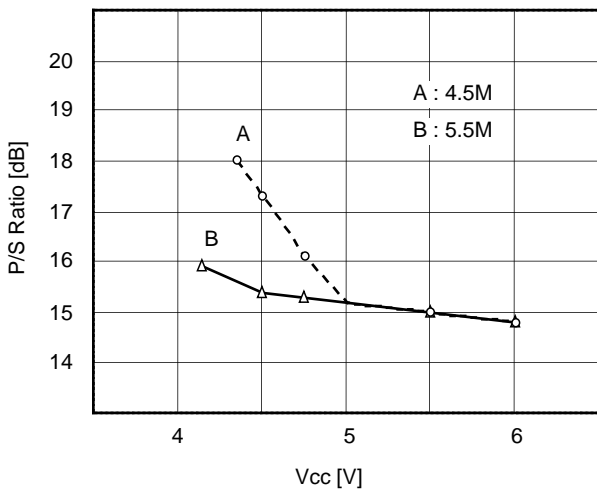
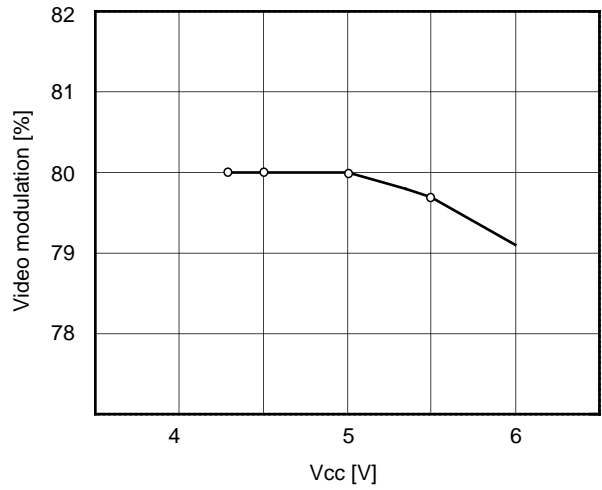
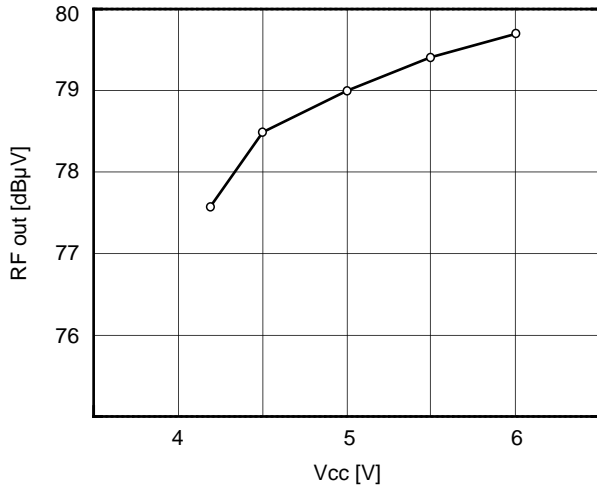

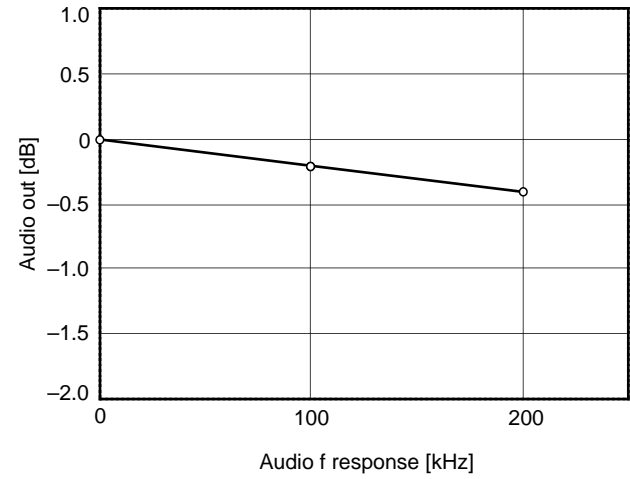
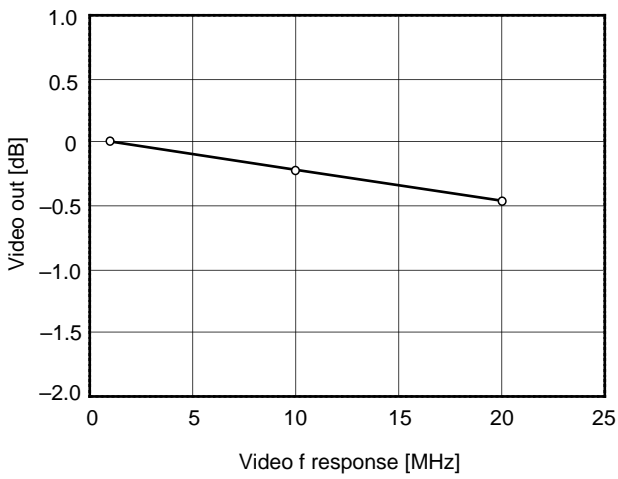
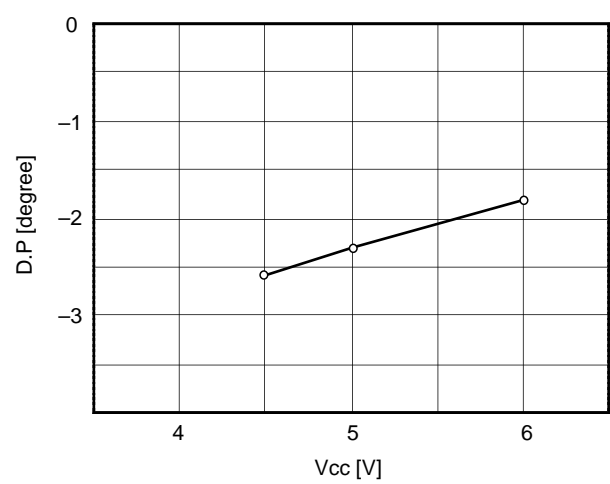
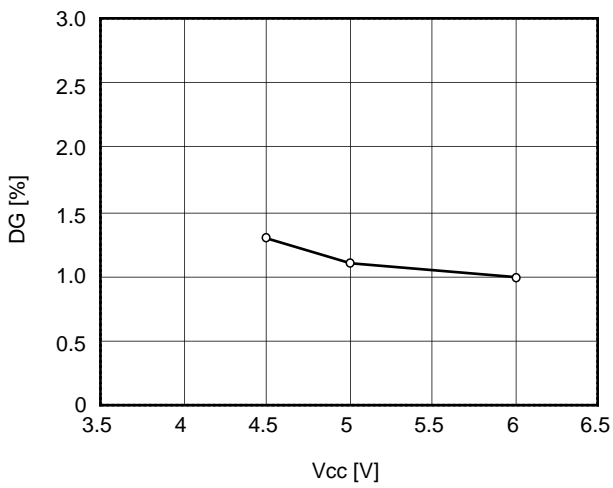
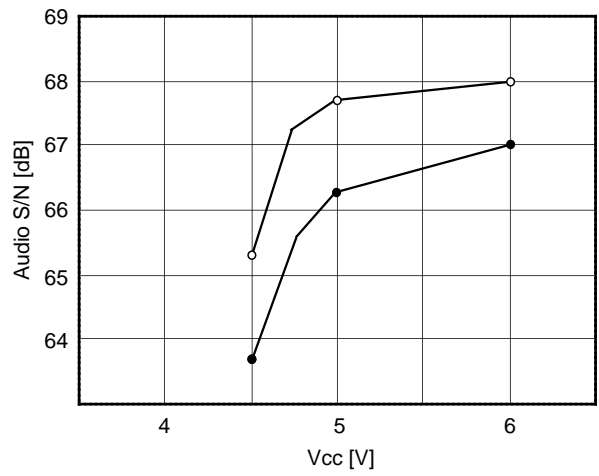
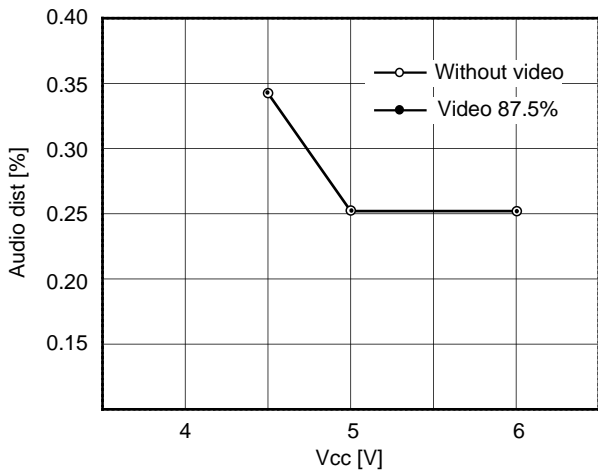

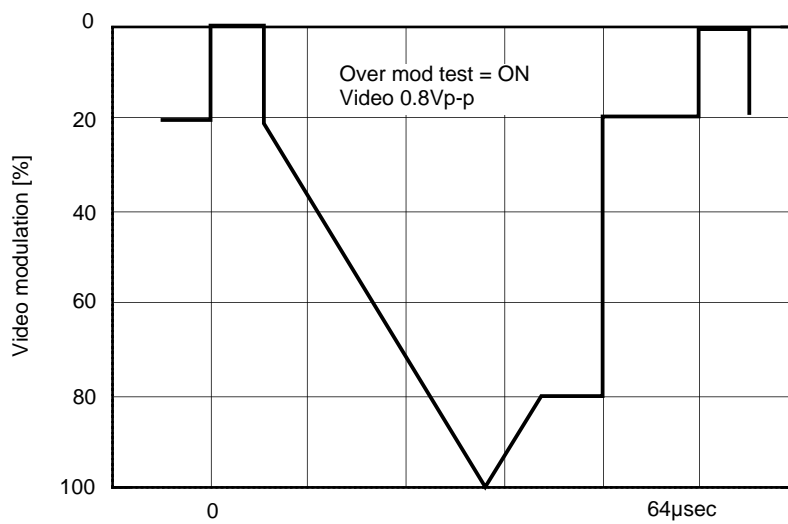
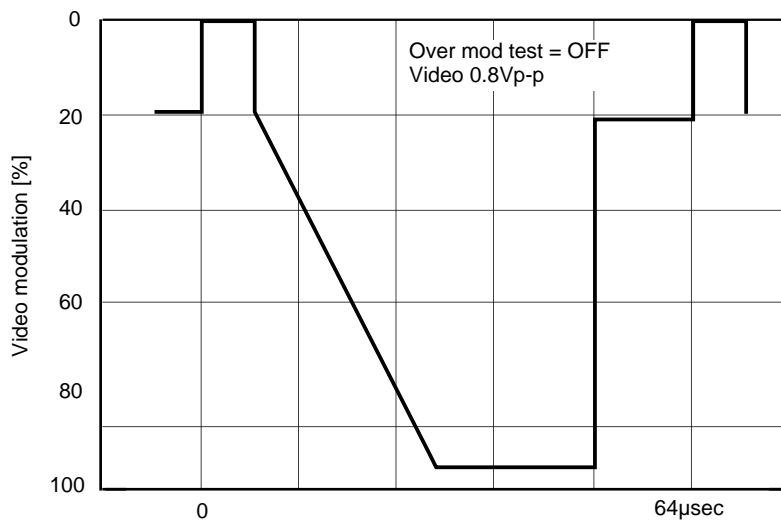
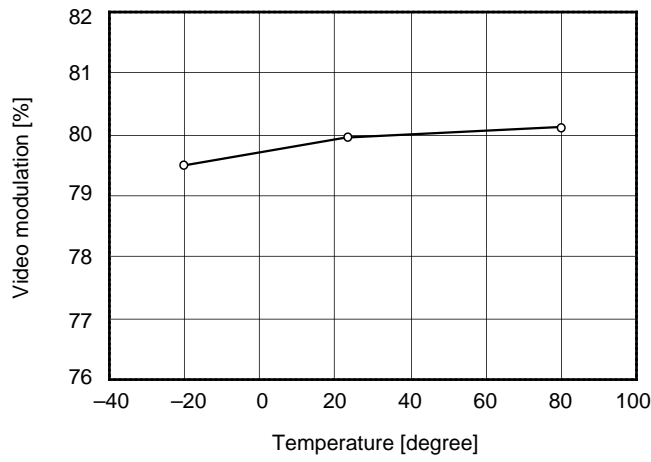

Package Outline

Unit: mm

24PIN SOP (PLASTIC)

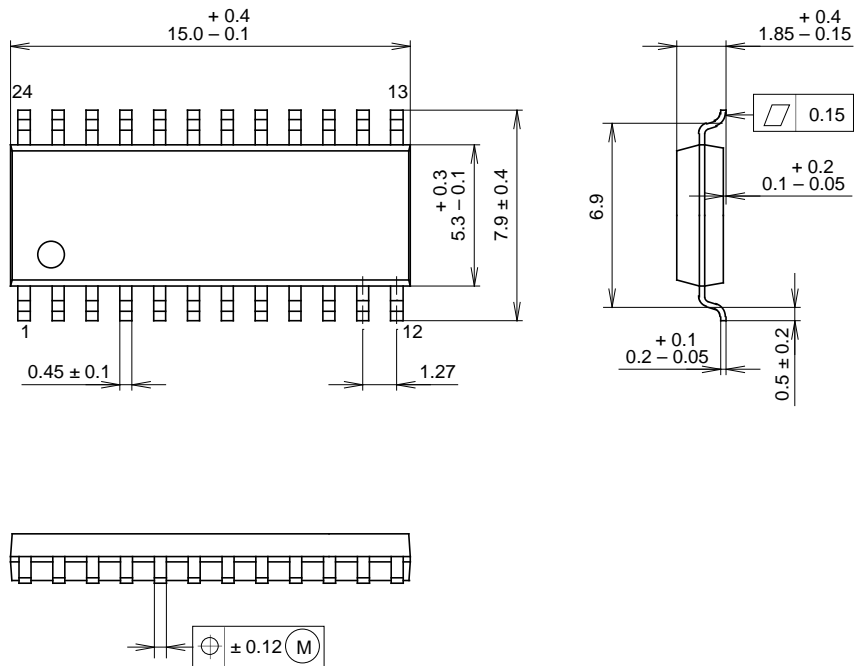

PACKAGE STRUCTURE

SONY CODE	SOP-24P-L01
EIAJ CODE	*SOP024-P-0300-A
JEDEC CODE	_____

MOLDING COMPOUND	EPOXY/PHENOL RESIN
LEAD TREATMENT	SOLDER PLATING
LEAD MATERIAL	COPPER ALLOY / 42ALLOY
PACKAGE WEIGHT	0.3g