

SONY

CXA3106AQ

PLL IC for LCD Monitor/Projector

Description

The CXA3106AQ is a PLL IC for LCD monitors/projectors with built-in phase detector, charge pump, VCO and counter.

The various internal settings are performed by serial data via a 3-line bus.

Applicable LCD monitor/projector resolution are NTSC, PAL, VGA, SVGA, XGA, and SXGA etc.

Features

- Supply voltage: 5V ± 10% single power supply
- Package: 48-pin QFP
- Power consumption: 350mW
- Sync input frequency: 10 to 100kHz
- Clock output signal frequency: 10 to 160MHz
- Clock delay: 1/16 to 20/16 CLK
- Sync delay: 1/16 to 20/16 CLK
- I/O level: TTL, PECL (complementary)
- Low clock jitter
- 1/2 clock output

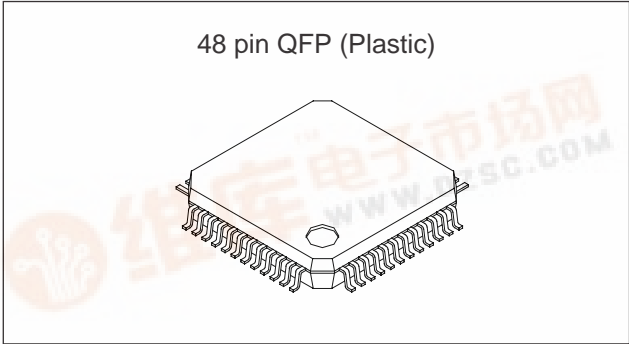

48 pin QFP (Plastic)

Functions

- Phase detector enable
- UNLOCK output
- Output TTL disable function
- Power save function (2 steps)

Applications

- CRT displays
- LCD projectors
- LCD monitors
- Multi-media

Pin Configuration (Top View)

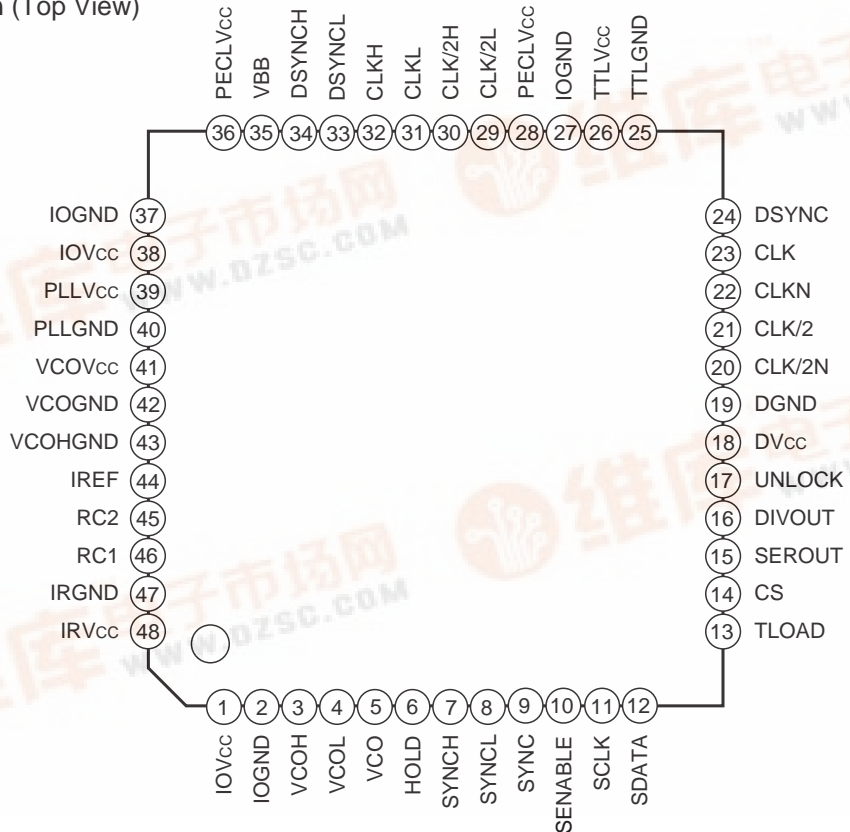

Absolute Maximum Ratings (Ta = 25°C)

• Supply voltage	IOVcc, DVcc, TTLVcc, PECLVcc, PLLVcc, VCOVcc, IRVcc, IOGND, DGND, TTLGND, VCOHGND, PLLGND, VCOGND, IRGND	-0.5 to +7.0	V
• Input voltage	VCOH, VCOL, SYNCH, SYNCL, VCO, HOLD, SYNC, SENABLE, SCLK, SDATA, TLOAD, CS RC2	IOGND - 0.5 to IOVcc + 0.5 IRGND - 0.5 to IRVcc + 0.5	V V
• Output current	SEROUT, DIVOUT, UNLOCK, CLK/2N, CLK/2, CLKN, CLK, DSYNCH, CLK/2L, CLK/2H, CLKL, CLKH, DSYNCH, DSYNCL, VBB IREF, RC1	-30 to +30 -2 to +2	mA mA
• Storage temperature Tstg		-65 to +150	°C
• Operating ambient temperature	Ta	-25 to +75	°C
• Allowable power dissipation	Pd	750	mW

Recommended Operating Conditions

		Min.	Typ.	Max.	
• Supply voltage	IOVcc, DVcc, TTLVcc, PECLVcc, PLLVcc, VCOVcc, IRVcc	4.75	5.00	5.25	V
	IOGND, DGND, TTLGND, VCOHGND, PLLGND, VCOGND, IRGND	-0.05	0	0.05	V
• Digital input	DIN (PECL) *1 H level	IOVcc - 1.1			
	DIN (PECL) *1 L level			IOVcc - 1.5	V
	DIN (TTL) *2 H level	2.0			V
	DIN (TTL) *2 L level			0.8	V
• SYNC, SYNCH, SYNCL input jitter				1.0	ns
• Operating temperature	Ta	-20		+75	°C

*1 VCOH, VCOL, SYNCH, SYNCL

*2 VCO, HOLD, SYNC, SENABLE, SCLK, SDATA, TLOAD, CS

Block Diagram

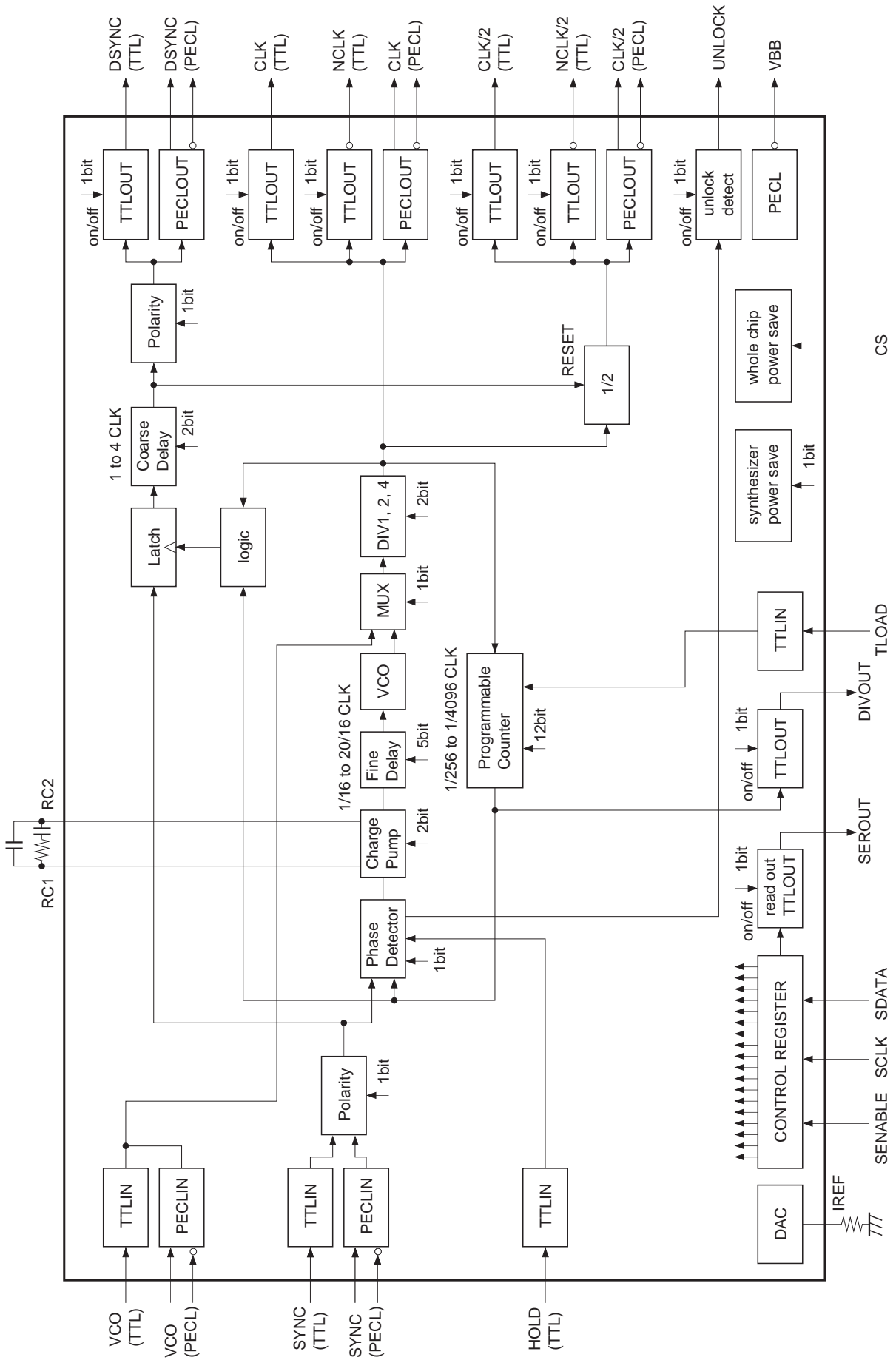

Pin No.	Symbol	Description	Reference voltage level
1	IOVcc	Digital power supply	5V
2	IOGND	Digital GND	0V
3	VCOH	External VCO input	PECL
4	VCOL	External inverted VCO input	PECL
5	VCO	External VCO input	TTL
6	HOLD	Phase detector disable signal input	TTL
7	SYNCH	Sync input	PECL
8	SYNCL	Inverted sync input	PECL
9	SYNC	Sync input	TTL
10	SENABLE	Control signal (enable)	TTL
11	SCLK	Control signal (clock)	TTL
12	SDATA	Control signal (data)	TTL
13	TLOAD	Programmable counter test input	TTL
14	CS	Chip select	TTL
15	SEROUT	Register read output	TTL
16	DIVOUT	Programmable counter test output	TTL
17	UNLOCK	Unlock signal output	TTL
18	DVcc	Digital power supply	5V
19	DGND	Digital GND	0V
20	CLK/2N	Inverted 1/2 clock output	TTL
21	CLK/2	1/2 clock output	TTL
22	CLKN	Inverted clock output	TTL
23	CLK	Clock output	TTL
24	DSYNC	Delay sync signal output	TTL
25	TTLGND	TTL output GND	0V
26	TTLVcc	TTL output power supply	5V
27	IOGND	Digital GND	0V
28	PECLVcc	PECL output power supply	5V
29	CLK/2L	Inverted 1/2 clock output	PECL
30	CLK/2H	1/2 clock output	PECL
31	CLKL	Inverted clock output	PECL
32	CLKH	Clock output	PECL
33	DSYNCL	Delay sync signal output	PECL
34	DSYNCH	Inverted delay sync signal output	PECL
35	VBB	PECL reference voltage	PECLVcc – 1.3V
36	PECLVcc	PECL output power supply	5V
37	IOGND	Digital GND	0V
38	IOVcc	Digital power supply	5V
39	PLLVcc	PLL circuit analog power supply	5V
40	PLLGND	PLL circuit analog GND	0V
41	VCOVcc	VCO circuit analog power supply	5V
42	VCOGND	VCO circuit analog GND	0V
43	VCOHGND	VCO SUB analog GND	0V
44	IREF	Charge pump current preparation	1.3V
45	RC2	External pin for LPF	1.7 to 4.4V
46	RC1	External pin for LPF	2.1V
47	IRGND	IREF analog GND	0V
48	IRVcc	IREF analog power supply	5V

Pin Description and I/O Pin Equivalent Circuit

Pin No.	Symbol	I/O	Reference voltage level	Equivalent circuit	Description
1	IOV _{cc}	—	5V		Digital power supply. Ground this pin to the ground pattern with a 0.1μF ceramic chip capacitor as close to the pin as possible.
2	IOGND	—	0V		Digital GND.
18	DV _{cc}	—	5V		Digital power supply.
19	DGND	—	0V		Digital GND.
25	TTLGND	—	0V		TTL output GND.
26	TTLV _{cc}	—	5V		TTL output power supply. Ground this pin to the ground pattern with a 0.1μF ceramic chip capacitor as close to the pin as possible.
27	IOGND	—	0V		Digital GND.
28	PECLV _{cc}	—	5V		PECL output power supply. Ground this pin to the ground pattern with a 0.1μF ceramic chip capacitor as close to the pin as possible.
36	PECLV _{cc}	—	5V		PECL output power supply. Ground this pin to the ground pattern with a 0.1μF ceramic chip capacitor as close to the pin as possible.
37	IOGND	—	0V		Digital GND.
38	IOV _{cc}	—	5V		Digital power supply. Ground this pin to the ground pattern with a 0.1μF ceramic chip capacitor as close to the pin as possible.
39	PLLV _{cc}	—	5V		PLL circuit analog power supply. Ground this pin to the ground pattern with a 0.1μF ceramic chip capacitor as close to the pin as possible.
40	PLLGND	—	0V		PLL circuit analog GND.
41	VCOV _{cc}	—	5V		VCO circuit analog power supply. Ground this pin to the ground pattern with a 0.1μF ceramic chip capacitor as close to the pin as possible.
42	VCOGND	—	0V		VCO circuit analog GND.
43	VCOHGND	—	0V		VCO SUB analog GND.
47	IRGND	—	0V		IREF analog GND.
48	IRV _{cc}	—	5V		IREF analog power supply. Ground this pin to the ground pattern with a 0.1μF ceramic chip capacitor as close to the pin as possible.

Pin No.	Symbol	I/O	Reference voltage level	Equivalent circuit	Description
3	VCOH	I	PECL		<p>External VCO input. Programmable counter test input (switchable by a control register). When using the VCO PECL input, open the Pin 5 VCO TTL input.</p>
4	VCOL	I	PECL		<p>External inverted VCO input. When open, this pin goes to the PECL threshold voltage ($IOV_{cc} - 1.3V$). Only the pin 3 VCOH input with VCOL input open can be also operated but complementary input is recommended in order to realize stable high-speed operation.</p>
7	SYNCH	I	PECL		<p>Sync input. When using the SYNCH PECL input, open the Pin 9 SYNC TTL input. The sync signal can be switched between positive/negative polarity by an internal register.</p>
8	SYNCL	I	PECL		<p>Inverted sync input. When open, this pin goes to the PECL threshold voltage ($IOV_{cc} - 1.3V$). Only the Pin 7 SYNCH input with SYNCL input open can be also operated but complementary input is recommended in order to realize stable high-speed operation.</p>

Pin No.	Symbol	I/O	Reference voltage level	Equivalent circuit	Description
5	VCO	I	TTL		External VCO input. Programmable counter test input (controlled by a control register). When using the VCO TTL input, open the Pin 3 VCOH and Pin 4 VCOL PECL inputs.
6	HOLD	I	TTL		Phase detector disable signal. Active high. When this pin is high, the phase detector output is held. This pin goes to high level when open. (See the HOLD Timing Chart.)
9	SYNC	I	TTL		Sync input. When using the SYNC TTL input, open the Pin 7 SYNCH and Pin 8 SYNCL PECL inputs. The sync signal can be switched between positive/negative polarity by a control register.
10	SENABLE	I	TTL		Control signal (enable) for setting the internal registers. When SENABLE is low, registers can be written; when high, registers can be read. (See the Control Register Table and Control Timing Chart.)
11	SCLK	I	TTL		Control signal (clock) for setting the internal registers. When SENABLE is low, SDATA is loaded to the registers at the rising edge of SCLK. When SENABLE is high, the register contents are output from SEROUT at the falling edge of SCLK. (See the Control Register Table and Control Timing Chart.)
12	SDATA	I	TTL		Control signal (data) for setting the internal registers. (See the Control Register Table and Control Timing Chart.)
13	TLOAD	I	TTL		Programmable counter test input. This pin is normally open status and high. Register contents can be loaded immediately to Programmable counter by setting TLOAD low during the programmable counter test mode.

Pin No.	Symbol	I/O	Reference voltage level	Equivalent circuit	Description
14	CS	I	TTL		<p>Chip select. When low, all circuits including the register circuit are set to the power save mode. When high, all circuits are set to operating mode.</p>
15	SEROUT	O	TTL		<p>Register read output. When SENABLE is high, the register contents are output from SEROUT at the falling edge of SCLK. (See the Control Register Timing Chart.) TTL output can be turned ON/OFF (high impedance) by a control register.</p>
16	DIVOUT	O	TTL		<p>Programmable counter test output. (See the I/O Timing Chart.) TTL output can be turned ON/OFF (high impedance) by a control register.</p>
20	CLK/2N	O	TTL		<p>Inverted 1/2 clock output. (See the I/O Timing Chart.) TTL output can be turned ON/OFF (high impedance) by a control register.</p>
21	CLK/2	O	TTL		<p>1/2 clock output. (See the I/O Timing Chart.) TTL output can be turned ON/OFF (high impedance) by a control register.</p>
22	CLKN	O	TTL		<p>Inverted clock output. (See the I/O Timing Chart.) TTL output can be turned ON/OFF (high impedance) by a control register.</p>
23	CLK	O	TTL		<p>Clock output. (See the I/O Timing Chart.) TTL output can be turned ON/OFF (high impedance) by a control register.</p>
24	DSYNC	O	TTL		<p>Delay sync signal output. (See the I/O Timing Chart.) TTL output can be turned ON/OFF (high impedance) and switched between positive/negative polarity by a control register.</p>

Pin No.	Symbol	I/O	Reference voltage level	Equivalent circuit	Description
17	UNLOCK	O	TTL		<p>Unlock signal output.</p> <p>This pin is an open collector output, and pulls in the current when a phase difference occurs. The UNLOCK sensitivity can be adjusted by connecting a capacitor and resistors to this output as appropriate. (See the UNLOCK Timing Chart.)</p> <p>TTL output can be turned ON/OFF (high impedance) by a control register.</p>
29	CLK/2L	O	PECL		<p>Inverted 1/2 clock output. (See the I/O Timing Chart.)</p> <p>This pin requires an external pull-down resistor.</p> <p>When not used, connect to PECLVcc without connecting a pull-down resistor.</p>
30	CLK/2H	O	PECL		<p>1/2 clock output. (See the I/O Timing Chart.)</p> <p>This pin requires an external pull-down resistor.</p> <p>When not used, connect to PECLVcc without connecting a pull-down resistor.</p>
31	CLKL	O	PECL		<p>Inverted clock output. (See the I/O Timing Chart.)</p> <p>This pin requires an external pull-down resistor.</p> <p>When not used, connect to PECLVcc without connecting a pull-down resistor.</p>
32	CLKH	O	PECL		<p>Clock output. (See the I/O Timing Chart.)</p> <p>This pin requires an external pull-down resistor.</p> <p>When not used, connect to PECLVcc without connecting a pull-down resistor.</p>
33	DSYNCL	O	PECL		<p>Delay sync signal output. (See the I/O Timing Chart.)</p> <p>This pin requires an external pull-down resistor.</p> <p>When not used, connect to PECLVcc without connecting a pull-down resistor.</p>
34	DSYNCH	O	PECL		<p>Inverted delay sync signal output. (See the I/O Timing Chart.)</p> <p>This pin requires an external pull-down resistor.</p> <p>When not used, connect to PECLVcc without connecting a pull-down resistor.</p>

Pin No.	Symbol	I/O	Reference voltage level	Equivalent circuit	Description
35	VBB	O	PECLV _{CC} -1.3V		<p>PECL reference voltage. When used, ground this pin to the ground pattern with a 0.1μF ceramic chip capacitor as close to the pin as possible.</p>
44	IREF	O	1.3V		<p>Charge pump current preparation. Connect to GND via an external resistor (1.6kΩ). Ground this pin to the ground pattern with a 0.1μF ceramic chip capacitor as close to the pin as possible.</p>
45	RC2	O	1.7 to 4.4V		<p>External pin for LPF. See the Recommended Operating Circuit for the external circuits. Note that external resistors and capacitors should be metal film resistors and temperature compensation capacitors which are relatively unaffected by temperature change.</p>
46	RC1	O	2.1V		<p>External pin for LPF. See the Recommended Operating Circuit for the external circuits.</p>

Control Register Table

Register No.	Register Name	DATA										ADDRESS		
		DATA7 MSB	DATA6	DATA5	DATA4	DATA3	DATA2	DATA1	DATA0	ADDR2 MSB	ADDR1	ADDR0 LSB		
Register 1	register read no	1	2	3	4	5	6	7	8					
	DIVREG1	VCO DIV Bit 7	VCO DIV Bit 6	VCO DIV Bit 5	VCO DIV Bit 4	VCO DIV Bit 3	VCO DIV Bit 2	VCO DIV Bit 1	VCO DIV Bit 0		0	0	1	
Register 2	register read no					9	10	11	12					
	DIVREG2					VCO DIV Bit 11	VCO DIV Bit 10	VCO DIV Bit 9	VCO DIV Bit 8	0	1	0		
Register 3	register read no		13	14	15	16	17	18	19					
	CENFREREG		DIV 1, 2, 4 Bit 1	DIV 1, 2, 4 Bit 0	N/A*1	N/A*1	N/A*1	N/A*1	N/A*1	0	1	1		
Register 4	register read no		20	21	22	23	24	25	26					
	DELAYREG		COARSE DELAY Bit 1	COARSE DELAY Bit 0	FINE DELAY Bit 4	FINE DELAY Bit 3	FINE DELAY Bit 2	FINE DELAY Bit 1	FINE DELAY Bit 0	1	0	0		
Register 5	register read no						27	28	29					
	CPREG						PD POL	C.Pump Bit 1	C.Pump Bit 0	1	0	1		
Register 6	register read no	30	31	32	33	34	35	36	37					
	TTLPOLREG	UNLOCK Enable	DSYNC Enable	NCLK/2 Enable	CLK/2 Enable	NCLK Enable	CLK Enable	DSYNC POL	SYNC POL	1	1	0		
Register 7	register read no					38	39	40	41					
	TESTPOWREG					DIVOUT Enable	Read out power	Synth power	VCO By-pass*2	1	1	1		

*1 Register read no. 15 to 19 are N/A.

*2 VCO By-pass at register read no. 41 is a MUX control bit in Block Diagram.

Electrical Characteristics

(Ta = 25°C, Vcc = 5V, GND = 0V)

Item	Symbol	Conditions	Min.	Typ.	Max.	Unit
Current consumption (excluding output current)						
Current consumption 1	Icc1	CS = H, Synth Power = 1	40	70	105	mA
Current consumption 2	Icc2	CS = H, Synth Power = 0	5	19	38	mA
Current consumption 3	Icc3	CS = L	3	14	24	mA
Digital input						
Digital high level input voltage (PECL)	V _{IH1}		IOV _{CC} -1.15			V
Digital low level input voltage (PECL)	V _{IL1}				IOV _{CC} -1.5	V
VCOL, SYNCL input open voltage (PECL)	V _{IO}			IOV _{CC} -1.3		V
Digital high level input current (PECL)	I _{IH1}	V _{IH} = IOV _{CC} - 0.8V	-100		100	μA
Digital low level input current (PECL)	I _{IL1}	V _{IL} = IOV _{CC} - 1.6V	-200		0	μA
Digital high level input voltage (TTL)	V _{IH2}		2.0			V
Digital low level input voltage (TTL)	V _{IL2}				0.8	V
Digital high level input current (TTL)	I _{IH2}	V _{IH} = 2.7V	-200		-20	μA
Digital low level input current (TTL)	I _{IL2}	V _{IL} = 0.5V	-500		-100	μA
HOLD characteristics						
RC1 input pin leak current	I _{leak}				1.0	nA
HOLD signal set-up time	T _{hs}		20			ns
HOLD signal hold time	T _{hh}		20			ns
Digital output						
Digital high level output voltage (PECL)	V _{OH1}	RL = 330Ω	PECLV _{CC} -1.1			V
Digital low level output voltage (PECL)	V _{OL1}	RL = 330Ω			PECLV _{CC} -1.6	V
PECL output reference voltage	V _{BB}	RL = 330Ω		PECLV _{CC} -1.3		V
Digital high level output voltage (TTL)	V _{OH2}	CL = 10pF	2.7			V
Digital low level output voltage (TTL)	V _{OL2}	CL = 10pF			0.5	V

Item	Symbol	Conditions	Min.	Typ.	Max.	Unit
UNLOCK output						
UNLOCK output current	Iunlock		-30			mA
SYNC input						
SYNC input frequency range	Fin		10		100	kHz
DSYNC output						
DSYNC output variable coarse delay time setting resolution	Rdsync1			2		bit
DSYNC output variable coarse delay time	Td1		1		4	CLK
DSYNC output variable fine delay time setting resolution	Rdsync2			5		bit
DSYNC output variable fine delay time	Td2		1/16		20/16	CLK
VCO characteristics						
DIV output frequency operation range 1	Fvco1	DIV = 1/1	40		160	MHz
DIV output frequency operation range 2	Fvco2	DIV = 1/2	20		80	MHz
DIV output frequency operation range 3	Fvco3	DIV = 1/4	10		40	MHz
VCO lock range	Vlock		1.7		4.4	V
VCO gain 1	Kvco1	DIV = 1/1	240	400	640	Mrad/sv
VCO gain 2	Kvco2	DIV = 1/2	120	200	320	Mrad/sv
VCO gain 3	Kvco3	DIV = 1/4	60	100	160	Mrad/sv
Charge pump current 1	Kpd1	C.Pump Bit = 00, IREF = 1.6kΩ	80	100	130	μA
Charge pump current 2	Kpd2	C.Pump Bit = 10, IREF = 1.6kΩ	350	400	500	μA
Charge pump current 3	Kpd3	C.Pump Bit = 11, IREF = 1.6kΩ	1350	1600	1800	μA
VCO counter bits	Rdiv2			12		bit

Item	Symbol	Conditions	Min.	Typ.	Max.	Unit
CLK (CLK, CLK/2) output						
CLK output (PECL) frequency range 1	Fclk1PECL	DIV = 1/1	40		160	MHz
CLK output (PECL) frequency range 2	Fclk2PECL	DIV = 1/2	20		80	MHz
CLK output (PECL) frequency range 3	Fclk3PECL	DIV = 1/4	10		40	MHz
CLK, CLK/2 output (PECL) rise time	TrPECL	10% to 90%, RL = 330Ω	1.0	1.5	2.0	ns
CLK, CLK/2 output (PECL) fall time	TfPECL	10% to 90%, RL = 330Ω	1.0	1.5	2.0	ns
CLK output (TTL) frequency range 1	Fclk1TTL	DIV = 1/1	40		80	MHz
CLK output (TTL) frequency range 2	Fclk2TTL	DIV = 1/2	20		80	MHz
CLK output (TTL) frequency range 3	Fclk3TTL	DIV = 1/4	10		40	MHz
CLK, CLK/2 output (TTL) rise time	TrTTL	10% to 90%, CL = 10pF	2.0	3.0	4.0	ns
CLK, CLK/2 output (TTL) fall time	TfTTL	10% to 90%, CL = 10pF	2.0	3.0	4.0	ns
CLK output (PECL, TTL) duty	Dclk2	CL = 10pF	40	50	60	%
SYNC input (PECL) and CLK output (PECL) delay offset	Td3	CL = 10pF		1		ns
CLK output (PECL) and DSYNC output (PECL) phase difference	Td4	CL = 10pF	1.5	2.4	3.0	ns
CLK output (PECL) and CLK/2 output (PECL) phase difference	Td5	CL = 10pF	0.0	0.8	1.0	ns
CLK output (PECL) and DIVOUT output (TTL) rise phase difference	Td6	CL = 10pF	10	14	19	ns
CLK output (PECL) and DIVOUT output (TTL) fall phase difference	Td7	CL = 10pF	8	11	14	ns
DSYNC, CLK, CLK/2 PECL output and TTL output phase difference	Td8	CL = 10pF	1.5	3.0	4.5	ns

Item	Symbol	Conditions	Min.	Typ.	Max.	Unit
CLK (CLK, CLK/2) output						
CLK vs. SYNC output jitter (NTSC)	Tj1p-p	triggered at SYNC Fsync = 15.73kHz (Crystal) Fclk = 12.27MHz N = 780	3.0	5.0	8.0	ns
CLK vs. SYNC output jitter (VGA)	Tj2p-p	triggered at SYNC Fsync = 31.47kHz (Crystal) Fclk = 25.18MHz N = 800	1.0	2.0	3.0	ns
CLK vs. SYNC output jitter (SVGA)	Tj3p-p	triggered at SYNC Fsync = 48.08kHz (Crystal) Fclk = 50.00MHz N = 1040	0.9	1.6	2.5	ns
CLK vs. SYNC output jitter (XGA)	Tj4p-p	triggered at SYNC Fsync = 56.48kHz (Crystal) Fclk = 75.00MHz N = 1328	0.8	1.5	2.0	ns
CLK vs. SYNC output jitter (SXGA)	Tj5p-p	triggered at SYNC Fsync = 80kHz (Crystal) Fclk = 136.00MHz N = 1700	0.6	1.0	1.4	ns
CLK vs. DSYNC output jitter	Tj6p-p	triggered at DSYNC			0.1	ns
Control registers						
SCLK frequency	SCLK	in write/read mode			12	MHz
SENABLE setup time	TENS	in write mode	3			ns
SENABLE hold time	TENH	in write mode	0			ns
SDATA setup time	TDS	in write mode	3			ns
SDATA hold time	TDH	in read mode	0			ns
SENABLE setup time	TNENS	in read mode	3			ns
SENABLE hold time	TNENH	in read mode	0			ns

Description of Block Diagram

Sync Input

Sync signals in the range of 10 to 100kHz can be input. Input supports both positive and negative polarity. PECL input can also be a single input.

When SYNC is positive polarity, the clock is regenerated in synchronization with the rising edge of the sync signal.

When SYNC is negative polarity, the clock is regenerated in synchronization with the falling edge of the sync signal.

VCO oscillation stops when there is no sync input.

Register: SYNC POL	1	0
SYNC input polarity	Positive	Negative

Phase Detector

The phase detector operates at the sync input frequency of 10 to 100kHz. The PD input polarity should be set to the default PD POL = 1. Phase comparison is performed at the edges.

The input circuit of the phase detector does not contain a hysteresis circuit, so the waveform must be shaped at the front end of the CXA3106AQ when inputting a noisy signal.

The phase detector HOLD signal is supplied by TTL. (See the HOLD Timing Chart.)

The PLL UNLOCK signal is output by an open collector.

(See the UNLOCK Timing Chart.)

Charge Pump

The gain (1, 1/4, 1/16) can be varied by changing the charge pump current using 2 bits of control register.

Register: C.Pump bit 1	0	1	1
Register: C.Pump bit 0	0	0	1
Charge pump current	100 μ A	400 μ A	1600 μ A

LPF

This is a loop filter comprised of the external capacitors and resistor.

Be sure to use metal film resistors with little temperature variation and a temperature-compensated capacitor.

In particular, the 0.33 μ F capacitor should be equivalent to high dielectric constant series capacitor type B or better. (electrostatic capacitance change ratio $\pm 10\%$: T = -25 to $+85^{\circ}\text{C}$)

VCO

The VCO oscillator frequency covers from 40 to 160MHz.

VCO Rear-end Counter

The VCO output is frequency divided to 1/1, 1/2 or 1/4 by switching 2 bits of control register.

The operating range can be expanded to 10 to 160MHz by combining the counter with a VCO frequency divider.

Register: DIV 1, 2, 4 bit 1	0	1	1
Register: DIV 1, 2, 4 bit 0	0	0	1
Counter frequency divisions	1/1	1/2	1/4

Feedback Programmable Counter

This counter can be set as desired from 256 to 4096 using 12 bits.

Frequency divisions = $(m + 1) \times 8 + n$, n: 3 bits (VCO DIV bits 0 to 2), m: 9 bits (VCO DIV bits 3 to 11)

When the register value is changed, the new setting is actually loaded to the counter when the counter value becomes "all 0".

Clock Output

When SYNC input is positive polarity, the clock is regenerated in synchronization with the rising edge of the sync signal.

The clock output delay time can be changed in the range of 1/16 to 20/16 CLK using 5 bits of control register. (See the I/O Timing Chart.)

Output is TTL and PECL (complementary), and supports both positive and negative polarity. Clock TTL output can also be turned off independently.

Register: Clock Enable	1	0
Clock output status	ON	OFF

1/2 Clock Output

Reset is performed at the delay sync timing and the clock output is frequency divided by 1/2. (See the I/O Timing Chart.)

Both odd and even output are TTL and PECL output. TTL output can also be turned off independently.

Register: Clock Enable	1	0
Clock output status	ON	OFF

Delay Sync Output

The front edge of the delay sync pulse is latched by the pulse obtained by frequency dividing the CLK regenerated by the PLL, so there is almost no jitter with respect to CLK. This front edge can be used as the reset signal for the system timing circuit.

The rear edge of the delay sync pulse is latched by the CLK regenerated by the PLL. This relationship is undefined for one clock as shown in the Timing Chart.

The delay sync output delay time can be varied in two stages. First, the delay time can be varied in the range of 1/16 to 20/16 CLK using 5 bits of control register, and then in the range of 1 to 4 CLK using 2 bits of control register. In other words, the total delay time is ((1/16 to 20/16) + (1 to 4)) CLK. (See the I/O Timing Chart.)

DSYNC output is TTL and PECL (complementary), and supports both positive and negative polarity. Clock TTL output can also be turned off.

Register: Clock Enable	1	0
Clock output status	ON	OFF

Lower delay line FINE DELAY bits 0 to 4	00000	00001	10011
Delay time	1/16CLK	2/16CLK	20/16CLK

Upper delay line COARSE DELAY bits 0 to 1	00	01	10	11
Delay time	1CLK	2CLK	3CLK	4CLK

Register: DSYNC POL	1	0
DSYNC output polarity	Positive	Negative

Control Circuit (3-bit address, 8-bit data)

The timing and input methods are described hereafter.

Feedback programmable counter control	REGISTER1, 2	12bit	VCO DIV Bit0 to 11
VCO rear-end counter control	REGISTER3	2bit	DIV1, 2, 4 Bit0, Bit1
Fine delay line control	REGISTER4	5bit	FINE DELAY Bit0 to 4
Coarse delay line control	REGISTER4	2bit	COARSE DELAY Bit0, Bit1
Charge pump current DAC control	REGISTER5	2bit	C.Pump Bit0, Bit1
Phase detector input positive/negative polarity control	REGISTER5	1bit	PD POL
Sync input positive/negative polarity control	REGISTER6	1bit	SYNC POL
Delay sync output positive/negative polarity control	REGISTER6	1bit	DSYNC POL
Clock TTL output OFF function	REGISTER6	1bit	CLK Enable
Inverted clock TTL output OFF function	REGISTER6	1bit	NCLK Enable
1/2 clock TTL output OFF function	REGISTER6	1bit	CLK/2 Enable
Inverted 1/2 clock TTL output OFF function	REGISTER6	1bit	NCLK/2 Enable
Delay sync TTL output OFF function	REGISTER6	1bit	DSYNC Enable
UNLOCK output OFF function	REGISTER6	1bit	UNLOCK Enable
Programmable counter input switching	REGISTER7	1bit	VCO By-pass
Power save with register contents held	REGISTER7	1bit	Synth power
Register read function power ON/OFF	REGISTER7	1bit	Read out power
Programmable counter TTL output OFF function	REGISTER7	1bit	DIVOUT Enable

Power Save

The CXA3106Q realizes 2-step power saving (all OFF, control registers only ON). This is controlled by a control register and the chip selector.

Step 1: Chip selector control

CS	H	L
Power save status	Power ON	All OFF

Step 2: Control register control

Register: Synth power	1	0
Power save status	Power ON	Control registers only ON

Readout Circuit (during test mode)

The control register contents can be read by serial data from SEROUT.
(See the Control Register Timing Chart.)

Register: Read out power	0	1
Readout status	Function OFF	Function ON

Programmable Counter Output (during test mode)

The programmable counter output is TTL output from the DIVOUT pin.

(See the I/O Timing Chart.)

This output is normally not used.

Register: DIVOUT Enable	0	1
DIVOUT output status	OFF	ON

TLOAD input (during test mode)

This control signal forcibly loads the control register contents to the programmable counter.

This signal is normally not used.

TLOAD	H	L
Forced load control status	Function OFF	Function ON

VCO input (during test mode)

This is the programmable counter test signal input pin.

This pin can be switched internally by the MUX circuit.

TTL and PECL input are possible.

This pin is normally not used.

Register: VCO By-pass	1	0
Input status	Internal VCO	External input

Control Register Timing

1) Write mode

Many CXA3106AQ functions can be controlled via a program. Characteristics are changed by setting the internal control register values via a serial interface comprised of three pins: SENABLE (Pin 10), SCLK (Pin 11) and SDATA (Pin 12). The write timing diagram is shown below.

Input the 8-bit data and 3-bit register address MSB first to the SDATA pin. Some registers are not 8 bits, but the data is input aligned with the LSB side in these cases. (See the Register Table.)

SENABLE is the enable signal and is active low. SCLK is the transfer clock signal, and data is loaded to the IC at the rising edge. When SENABLE rises, SCLK must be high. (Registers are set at the rising edge of SENABLE.) When SENABLE falls, SCLK may be either high or low.

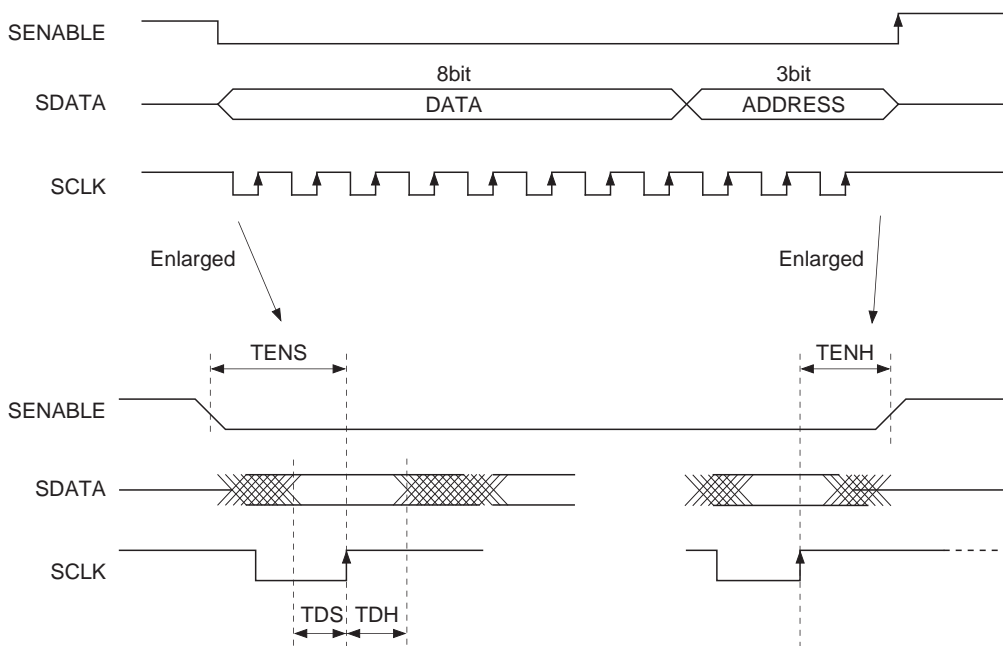

For example, when inputting a 16-bit signal, the initial 5 bits are invalid and the latter 11 bits are valid. This is to say that the latter 11 bits are loaded to the register.

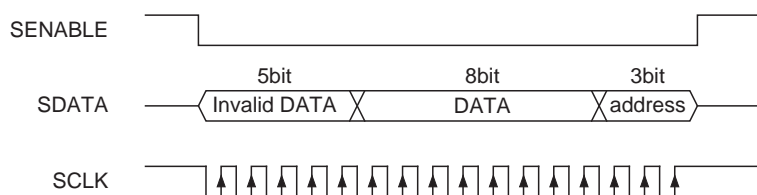

The settings of the frequency divider (2 bits, DIV1, 2, 4) and programmable counter (12 bits, VCODIV) at the rear end of the VCO are transferred in the order shown below. (The data will be set when the three registers are transferred.)

First DIVREG2, CENFREREG and DIVREG1 are set, and then the data is transferred independently at the timings shown below.

DIVREG2 (upper 4 bits of VCODIV)



CENFREREG (2 bits of DIV1, 2, 4)



DIVREG1 (lower 8 bits of VCODIV)

All three of the above registers must be changed even when changing only DIV1, 2, 4 (2 bits). This is the same when changing only VCODIV (12 bits).

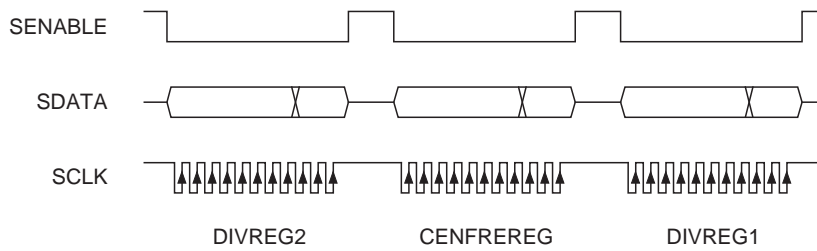

2) Read mode

Data can be transferred from the shift register to the data register only when SENABLE is high.

Binary data can be read from the data register by inputting SCLK when SENABLE is high. Data is loaded from the data register to the SCAN PATH circuit each time one clock is input to SCLK, and is output sequentially from the register read no. 1 data (VCODIV bit 7) through the SEROUT pin. When the 41st SCLK clock pulse is input, the register read no. 41 data (VCO By-pass) is output. Then, when the 42nd clock pulse is input to SCLK, the output returns to the register read no. 1 data (VCODIV bit 7) and the data output is repeated. Also, the data output from the SCAN PATH circuit is automatically reloaded even when the shift register data is changed during data output.

Note) Since all registers do not have 8 bits, only the valid bits of each register are loaded to the SCAN PATH circuit. (See the Control Register Table for the actual register read no.)

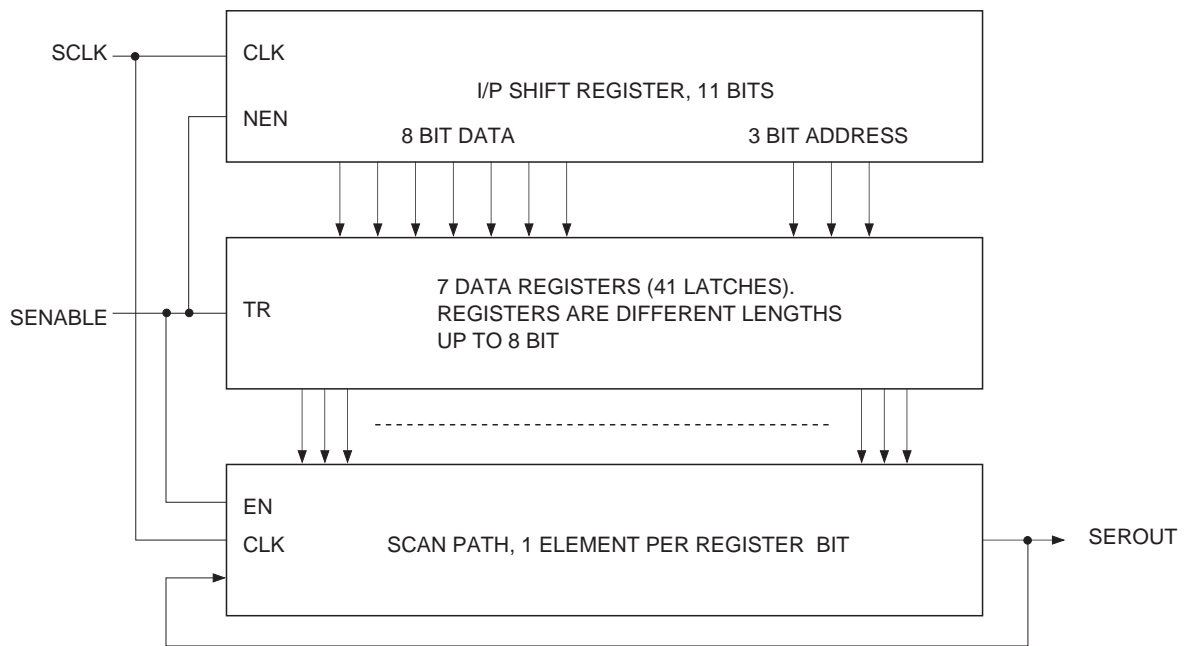

Block Diagram during Read Mode

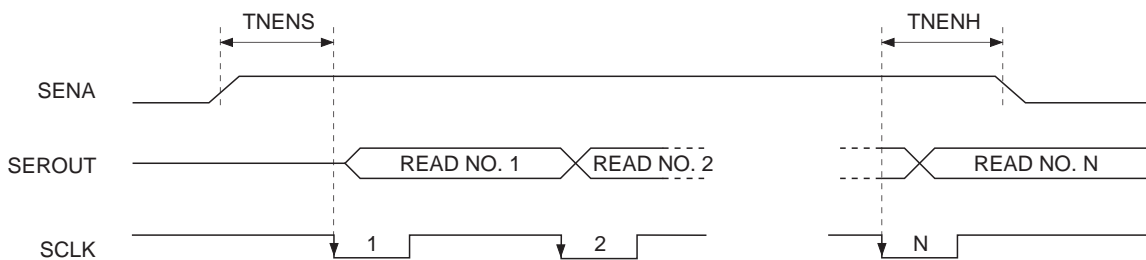

Timing Chart during Read Mode

Timing Charts
1. I/O timing

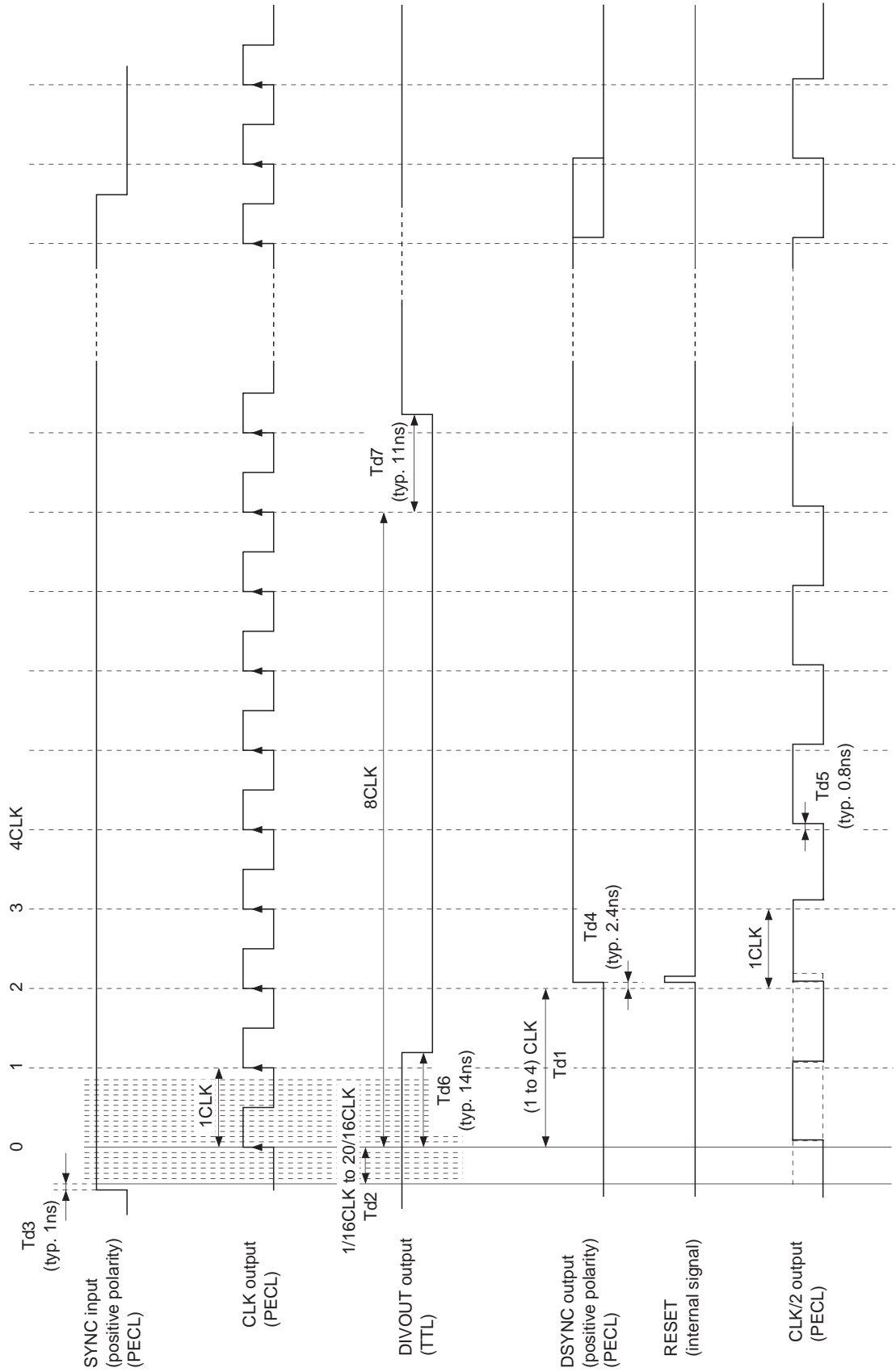

2. HOLD timing

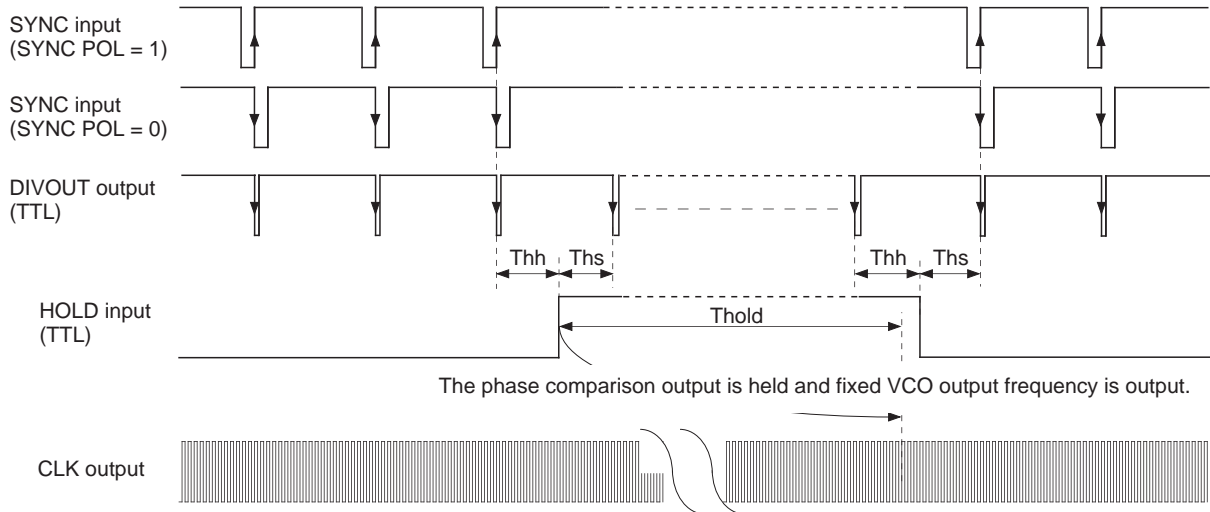

HOLD signal set-up time (T_{hs}) is a time from the rising edge of HOLD signal to the falling edge of DIVOUT. Or, when SYNC POL = 1, it is a time from the falling edge of HOLD signal to the rising edge of SYNC; when SYNC POL = 0, it is the time from the falling edge of HOLD signal to the falling edge of SYNC.

HOLD signal hold time (T_{hh}) is the time from the falling edge of DIVOUT to falling edge of HOLD signal. Or, when SYNC POL = 1, it is the time from the rising edge of SYNC to the rising edge of HOLD signal; when SYNC POL = 0, it is the time from the falling edge of SYNC to the rising edge of HOLD signal.

When the HOLD input is held, the CLK frequency fluctuation can be calculated as follows.

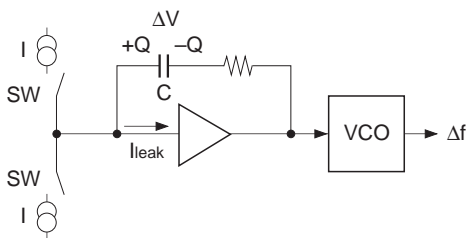

$$C \cdot \Delta V = Q = I_{leak} \cdot T_{hold}$$

- C: Loop filter capacitance
- ΔV : Voltage variation due to leak current
- I_{leak} : Internal amplifier leak current
- T_{hold} : Hold time

$$\Delta V = I_{leak} \cdot T_{hold} / C$$

$$\Delta f = \Delta V \cdot KVCO = I_{leak} \cdot T_{hold} / C \cdot KVCO$$

For example, assuming $f = 100\text{MHz}$, $I_{leak} = 1\text{nA}$, $T_{hold} = 1\text{ms}$, $C = 0.33\mu\text{F}$, and $KVCO = 2\pi \cdot 65\text{MHz}$, then:

$$\Delta V = 1 \times 10^{-9} \cdot 1 \times 10^{-3} / (0.33 \times 10^{-6}) = 3 \times 10^{-6} \text{ [V]}$$

$$\Delta f = 1 \times 10^{-9} \cdot 1 \times 10^{-3} / (0.33 \times 10^{-6}) \cdot 65 \times 10^6 = 197 \text{ [Hz]}$$

3. Relationship between SYNC input and DSYNC output during HOLD

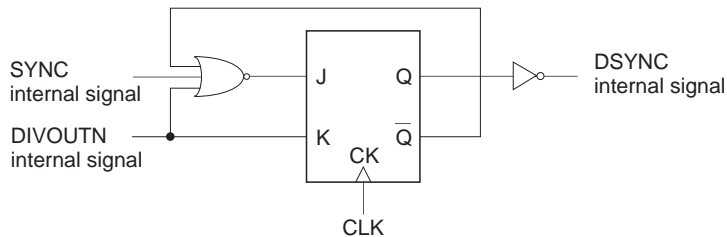

When the above SYNC internal and DIVOUTN internal signals are input, the DSYNC internal signal is output as shown the table below.

First, when SYNC = L and DIVOUTN = L, it does not stand up because the output of $\bar{Q} = \text{DSYNC} = \text{L}$ and $\bar{Q} = \text{DSYNC} = \text{H}^{**}$ (unchanged with the previous data) is exclusive logic. And, $\bar{Q} = \text{DSYNC} = \text{H}^{**}$ is the impossible output. Therefore, it is as follows.

1. DSYNC = L when SYNC = L and DIVOUTN = L.
2. DSYNC = H* or L* (unchanged with the previous data) when SYNC = H and DIVOUTN = L.
3. DSYNC = H when DIVOUTN = H (SYNC = H or L)

SYNC	DIVOUTN	J	K	Q	\bar{Q}	DSYNC
L	L	L	L	L**	H**	H**
		H	L	H	L	L
L	H	L	H	L	H	H
H	L	L	L	L*	H*	H*
		L	L	H*	L*	L*
H	H	L	H	L	H	H

(*) and (**) are unchanged with the previous data.

The polarity of SYNC internal signal and DSYNC internal signal has a relationship between the setting of the respective SYNC POL and DSYNC POL. The below diagrams are the examples that show the relationship between SYNC input and DSYNC output and between the SYNC POL and DSYNC POL during HOLD.

CASE1

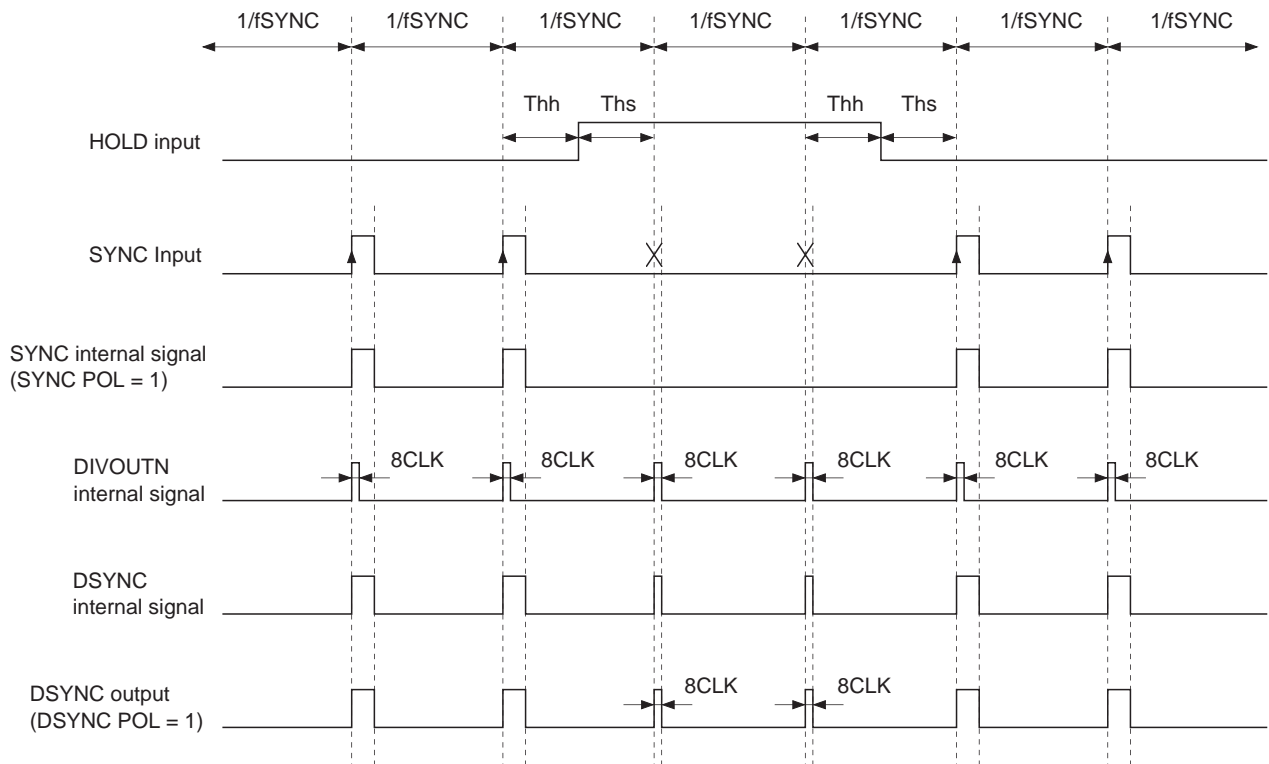

CASE2

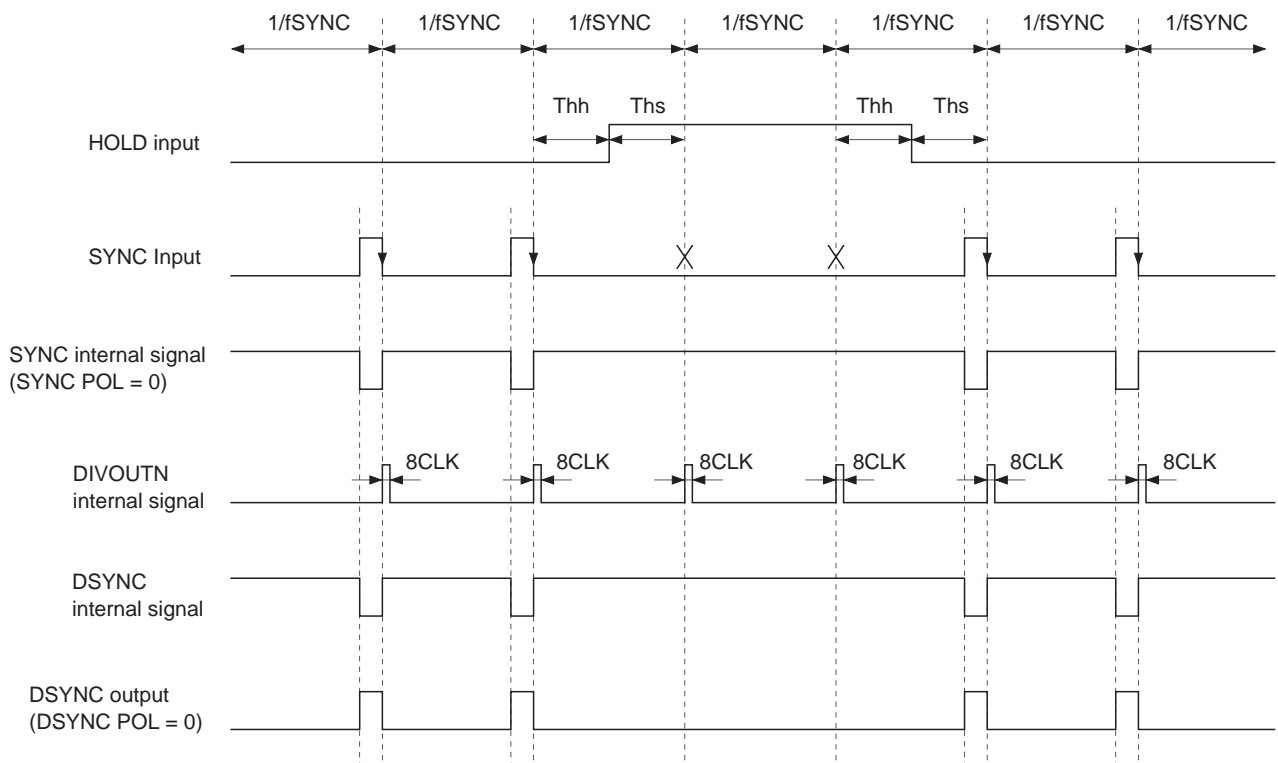

CASE3

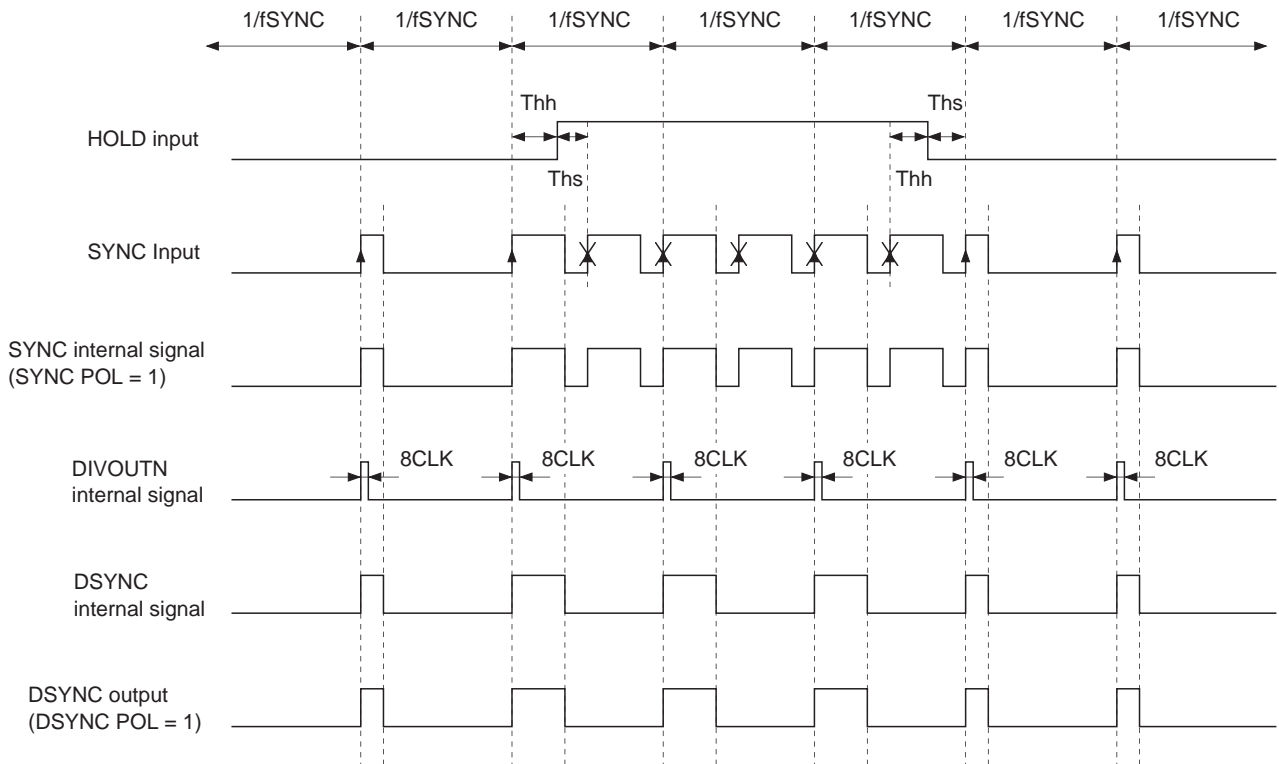

CASE4

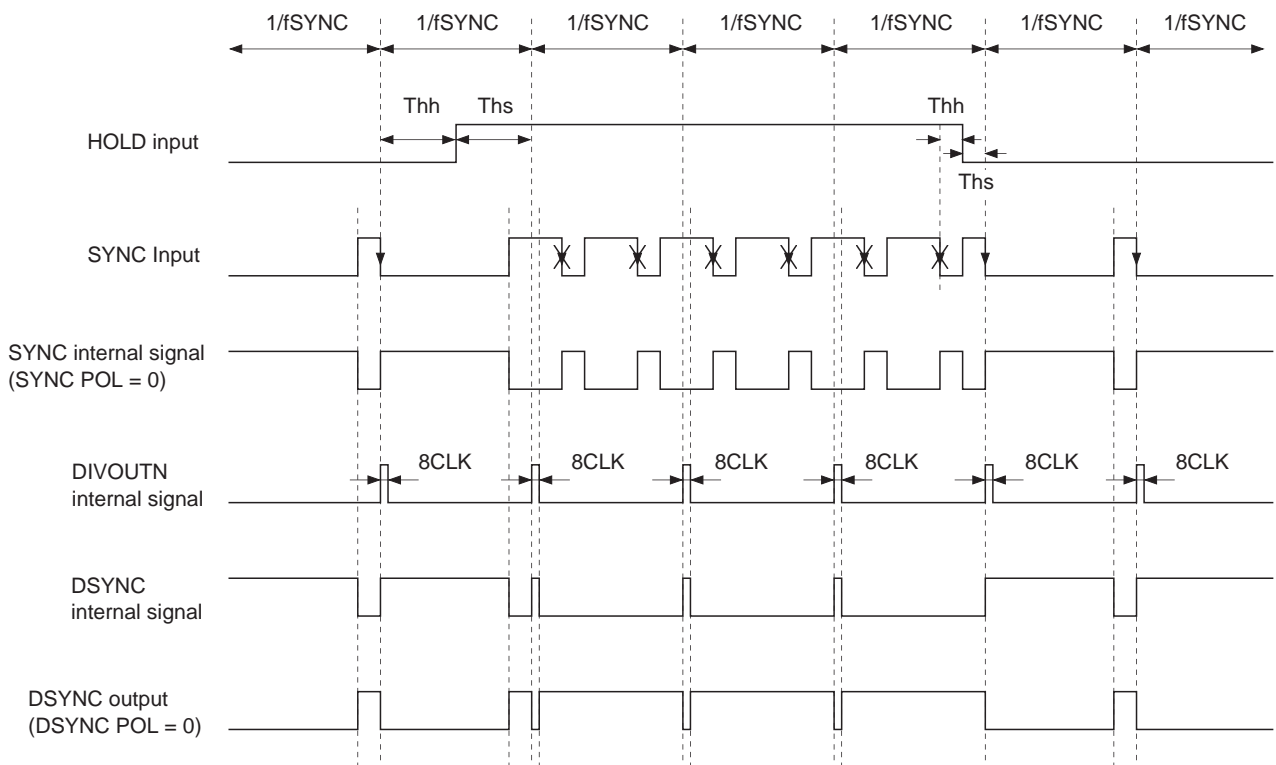

CASE5

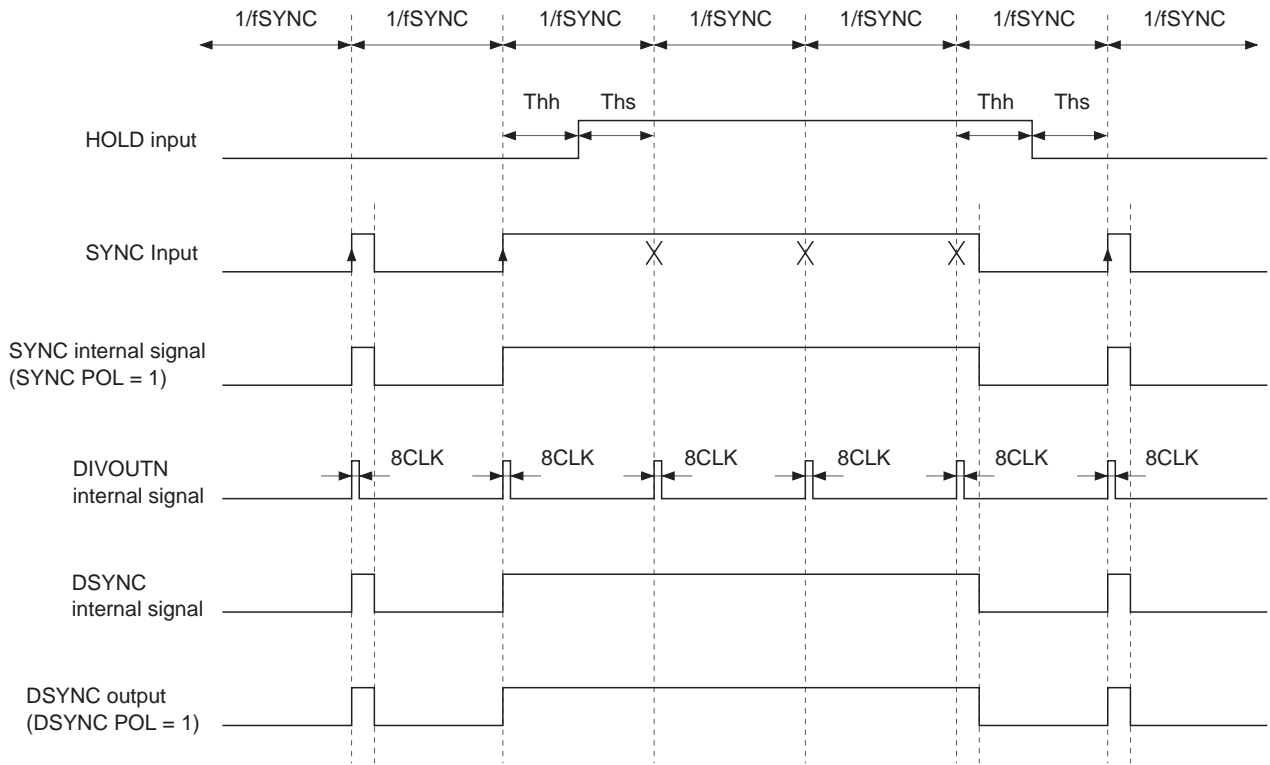

CASE6

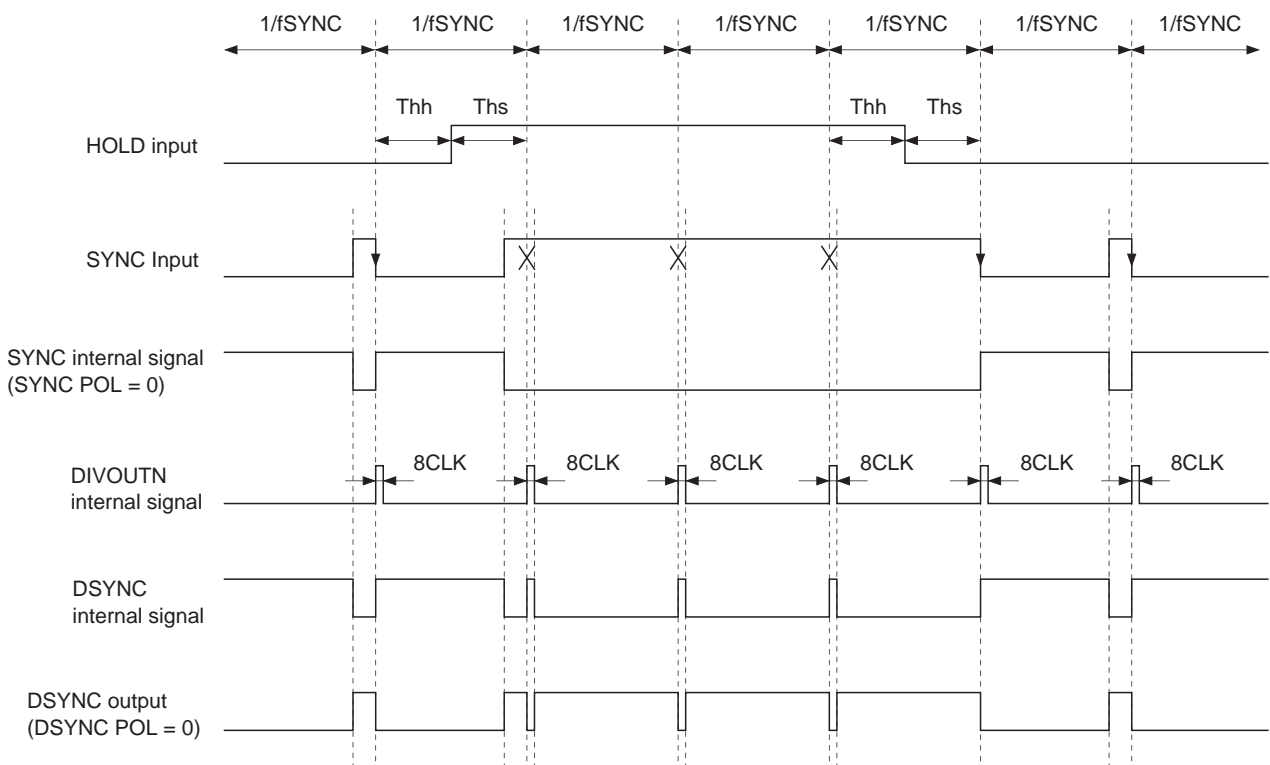

4. UNLOCK timing

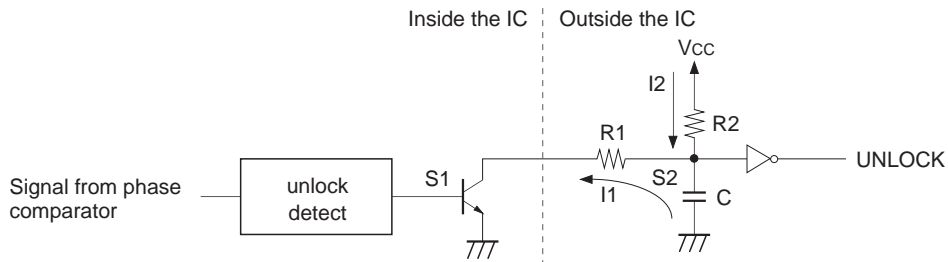

The unlock detect output is an open collector. When unlock detect output S1 goes high, the current I1 is pulled in. The UNLOCK sensitivity can be adjusted by connecting external resistors (R1, R2) and a capacitor (C) to this output pin as appropriate and changing these values. Operation during three modes is described below.

CASE 1: When there is no phase difference, that is to say, when the PLL is locked.
 The S1 signal is low and the S2 signal is high.
 The UNLOCK output remains low.

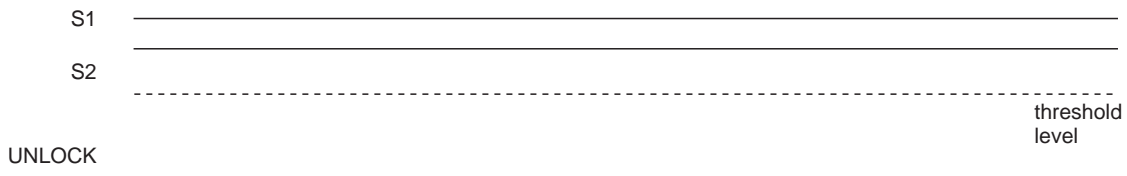

CASE 2: When there is a phase difference, that is to say, when the S1 signal goes high and low as shown in the figure below, the fall slew rate of the S2 signal is determined by the current I1 flowing into that open collector. Therefore, increasing the resistance R1 causes the S2 signal fall slew rate to become slower. Also, since the S2 signal rise slew rate is determined by the current I2, reducing the resistance R2 causes the S2 signal rise slew rate to become faster. If this integrated S2 signal does not fall below the threshold level of the next inverter, the UNLOCK signal stays low, and the PLL is said to be locked.

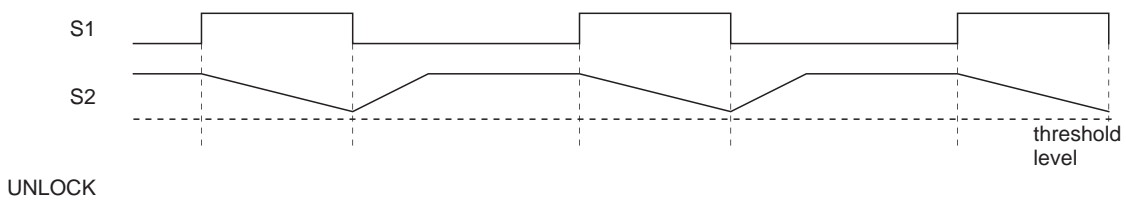

CASE 3: However, even if a phase difference exists as shown above, if the resistance R1 is reduced, the current I1 flowing into the open collector increases, and the S2 signal fall slew rate becomes faster. Also, if the resistance R2 is increased, the S2 signal rise slew rate becomes slower. If this integrated S2 signal falls below the threshold level of the next inverter, the UNLOCK signal goes from low to high, and the PLL is said to be unlocked.

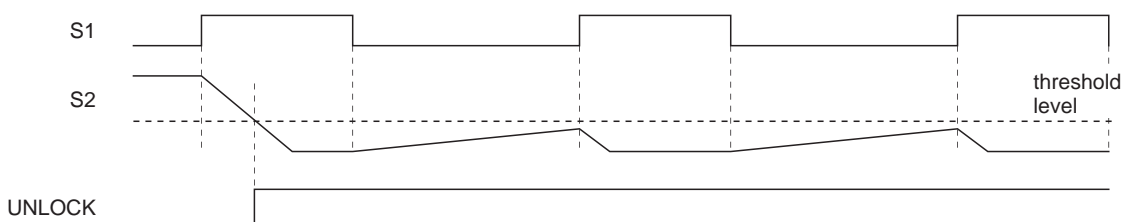

Charge Pump and Loop Filter Settings

The CXA3106Q's charge pump is a constant-current output type as shown below.

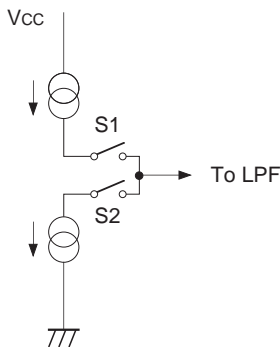

When a constant-current output charge pump circuit is used inside the PLL, the phase detector output acts as a current source, and the dimension of its transmittance KPD is A/rad. Also, when considering the VCO input as a voltage, the LPF transmittance dimension must be expressed in ohms ($\Omega = V/A$).

Therefore, the PLL transmittance when a constant-current output charge pump circuit is used is as follows.

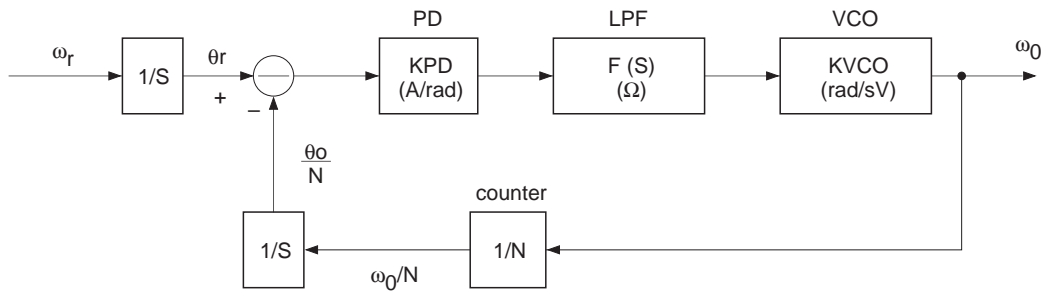

The PLL closed loop transmittance is obtained by the following formula.

$$\frac{\theta_o/N}{\theta_r} = \frac{KPD \cdot F(S) \cdot KVCO \cdot 1/N \cdot 1/S}{1 + KPD \cdot F(S) \cdot KVCO \cdot 1/N \cdot 1/S} \dots (1)$$

Here, KPD, F (S), and KVCO are:

- KPD: Phase comparator gain (A/rad)
- F (S): Loop filter transmittance (Ω)
- KVCO: VCO gain (rad/sV)

*1 The reason for the 1/S inside the phase detector is as follows.

$$\theta_o(t)/N = \int_0^t \omega_o(t)/N dt + \theta_o(t=0)/N \dots (a)$$

$$\theta_o(t=0) = 0$$

$$\theta_o(t)/N = \int_0^t \omega_o(t)/N dt \dots (b)$$

Performing Laplace conversion:

$$\theta_o(S)/N = \frac{1}{S} W_o(S)/N \dots (c)$$

The loop filter F (S) is described below.

The loop filter smooths the output pulse from the phase comparator and inputs it as the DC component to the VCO. In addition to this, however, the loop filter also plays an important element in determining the PLL response characteristics.

Typical examples of loop filters include lag filters, lag-lead filters, active filters, etc. However, the CXA3106AQ's LPF is a current input type active filter as shown below, so the following calculations show an actual example of deriving the PLL closed loop transmittance when using this type of filter and then using this transmittance to create a formula for setting the filter constants.

Current input type active filter

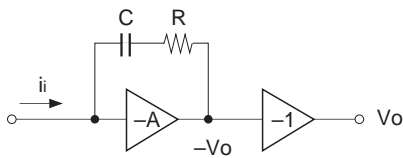

The filter transmittance is as follows.

$$\frac{VO}{A} + VO = (R + \frac{1}{SC}) \cdot ii$$

$$F(S) = \frac{1 + SRC}{SC} \cdot \frac{A}{1 + A}$$

$$= \frac{1 + S\tau}{SC} \cdot \frac{A}{1 + A}$$

$$\therefore \tau = RC$$

Here, assuming $A > 1$, then:

$$F(S) = \frac{1 + S\tau}{SC} \dots\dots\dots (2)$$

The Bode diagram for formula (2) is as follows.

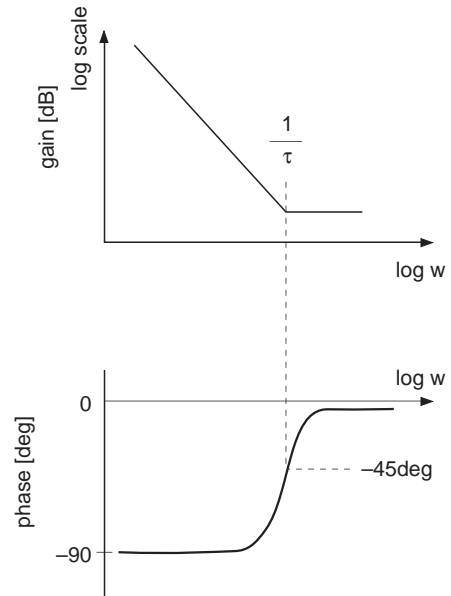

Next, substituting (2) into (1) and obtaining the overall closed loop transmittance for the PLL:

$$\frac{\theta_o/N}{\theta_r} = \frac{\frac{KPD \cdot KVCO \cdot \tau}{NC} \cdot S + \frac{KPD \cdot KVCO}{NC}}{S^2 + \frac{KPD \cdot KVCO \cdot \tau}{NC} \cdot S + \frac{KPD \cdot KVCO}{NC}} \dots (3)$$

$$= \frac{2\zeta\omega_n S + \omega_n^2}{S^2 + 2\zeta\omega_n S + \omega_n^2} \dots\dots\dots (4)$$

$$\omega_n = \sqrt{\frac{KPD \cdot KVCO}{NC}} \dots\dots\dots (5)$$

$$\zeta = \frac{1}{2} \omega_n \tau \dots\dots\dots (6)$$

Here, ω_n and ζ are as follows.

ω_n characteristic angular frequency:

The oscillatory angular frequency when PLL oscillation is assumed to have been maintained by the loop filter and individual loop gains is called the characteristic angular frequency: ω_n .

ζ damping factor:

This is the PLL transient response characteristic, and serves as a measure of the PLL stability. It is determined by the loop gain and the loop filter.

A capacitor C2 is added to the actual loop filter.

This added capacitor C2 is used to reduce the R noise, and a value of about 1/10 to 1/1000 of C1 should be selected as necessary.

Current input type active filter with added capacitor C2

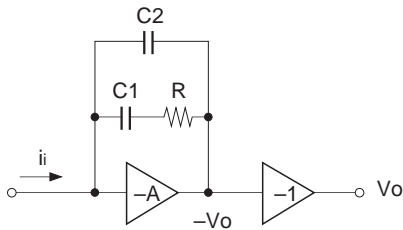

The filter transmittance is as follows.

$$F(S) = \frac{1 + C1 \cdot R \cdot S}{S ((C1 + C2) + C1 \cdot C2 \cdot R \cdot S)}$$

$$= \frac{1 + \tau_1 \cdot S}{S (C1 + C2) (1 + \tau_2 \cdot S)} \dots\dots\dots (7)$$

$$\tau_1 = C1 \cdot R$$

$$\tau_2 = \frac{C1 \cdot C2 \cdot R}{C1 + C2}$$

Here, assuming $C2 = C1/100$, then:

$$\tau_2 = \frac{C1 \cdot C1/100 \cdot R}{C1 + C1/100}$$

$$= \frac{1}{101} C1 \cdot R$$

$$= \frac{1}{101} \tau_1$$

The Bode diagram for formula (7) is as follows.

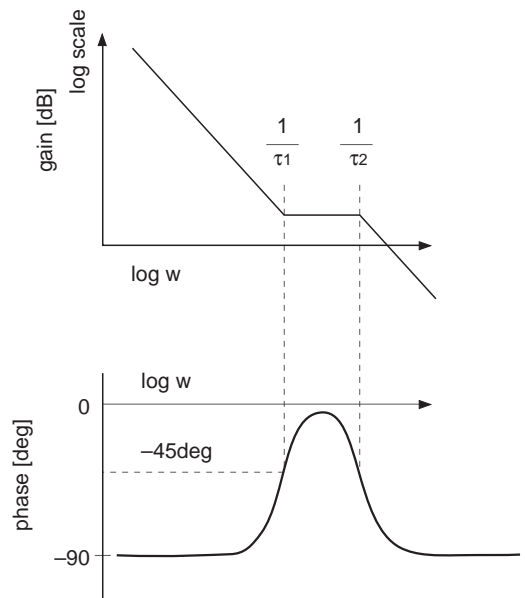

Next, the various parameters inside an actual CXA3106AQ are obtained.
 The CXA3106AQ's charge pump output block and the LPF circuit are as follows.

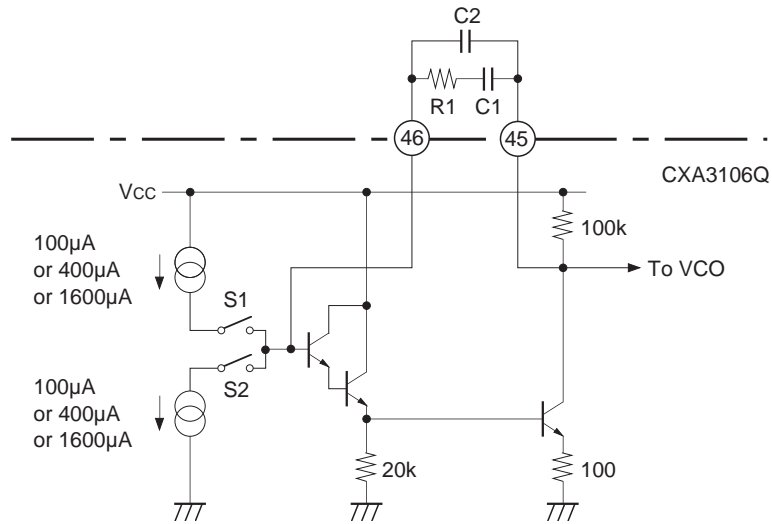

First, KPD is as follows.

$$KPD = 100\mu/2\pi \text{ or } 400\mu/2\pi \text{ or } 1600\mu/2\pi \text{ (A/rad)}$$

Typical KVCO characteristics curves for the CXA3106Q's internal VCO are as follows.

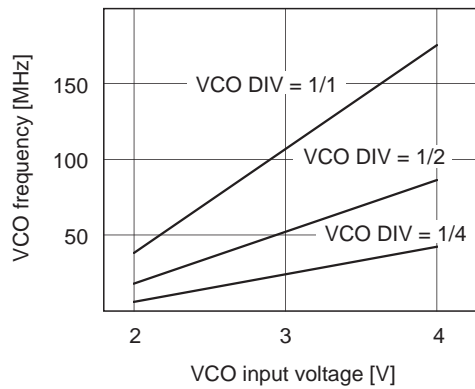

Therefore, KVCO is as follows.

$$KVCO = 2\pi \cdot 65M \text{ or } 2\pi \cdot 32.5M \text{ or } 2\pi \cdot 16.25M \text{ (rad/s/V)}$$

ω_n and ζ calculated for various types of computer signals are shown below.

Here, the various parameters are as follows.

FSYNC: Input H sync frequency

FCLK: Output clock frequency

KPD*2 π : Phase comparator gain *2 π (KPD*2 π = +100 or 400 or 1600)

KVCO/2 π : VCO gain
 (when VCO DIV = 1/1, KVCO/2 π = 65)
 (when VCO DIV = 1/2, KVCO/2 π = 65/2)
 (when VCO DIV = 1/4, KVCO/2 π = 65/4)

N: Counter value

C1: Loop filter capacitance value

R1: Loop filter resistance value

	Resolution	FSYNC	FCLK	KPD × 2 π	C.Pump setting		KVCO/2 π	DIV1.2.4 setting		N setting	C1	R1	ω_n	f_n	ζ
		kHz	MHz	μ A	Bit1	Bit0	MHz/V	Bit1	Bit0		μ F	Ω	kHzrad	kHz	
NTSC		15.734	12.27	100	0	0	65/4	1	1	780	0.33	3300	2.51	0.40	1.37
NTSC		15.734	18.41	400	1	0	65/4	1	1	1170	0.33	3300	4.10	0.65	2.23
NTSC		15.734	24.55	400	1	0	65/4	1	1	1560	0.33	3300	3.55	0.57	1.93
PAL		15.625	14.69	100	0	0	65/4	1	1	940	0.33	3300	2.29	0.36	1.25
PAL		15.625	22.03	400	1	0	65/4	1	1	1410	0.33	3300	3.74	0.59	2.04
PAL		15.625	29.38	400	1	0	65/4	1	1	1880	0.33	3300	3.24	0.52	1.76
PC-98	640 × 400	24.82	21.05	400	1	0	65/4	1	1	848	0.33	3300	4.82	0.77	2.62
VGA	640 × 480	31.47	25.18	400	1	0	65/4	1	1	800	0.33	3300	4.96	0.79	2.70
MAC	640 × 480	35.00	30.24	400	1	0	65/4	1	1	864	0.33	3300	4.77	0.76	2.60
VESA	640 × 480	37.86	31.50	400	1	0	65/4	1	1	832	0.33	3300	4.87	0.77	2.65
SVGA	800 × 600	35.16	36.00	400	1	0	65/2	1	0	1024	0.33	3300	6.20	0.99	3.38
SVGA	800 × 600	37.88	40.00	400	1	0	65/2	1	0	1056	0.33	3300	6.11	0.97	3.33
SVGA	800 × 600	46.88	49.50	400	1	0	65/2	1	0	1056	0.33	3300	6.11	0.97	3.33
SVGA	800 × 600	48.08	50.00	400	1	0	65/2	1	0	1040	0.33	3300	6.15	0.98	3.35
SVGA	800 × 600	53.67	56.25	400	1	0	65/2	1	0	1048	0.33	3300	6.13	0.98	3.34
MAC	832 × 624	49.72	57.28	400	1	0	65/2	1	0	1152	0.33	3300	5.85	0.93	3.18
XGA	1024 × 768	48.36	65.00	400	1	0	65/2	1	0	1344	0.33	3300	5.41	0.86	2.95
XGA	1024 × 768	56.48	75.00	400	1	0	65/2	1	0	1328	0.33	3300	5.45	0.87	2.97
XGA	1024 × 768	60.02	78.75	400	1	0	65/2	1	0	1312	0.33	3300	5.48	0.87	2.98
MAC	1024 × 768	60.24	80.00	400	1	0	65/2	1	0	1328	0.33	3300	5.45	0.87	2.97
XGA	1024 × 768	68.68	94.50	400	1	0	65/1	0	0	1376	0.33	3300	7.57	1.20	4.12
SXGA	1280 × 1024	46.43	78.75	400	1	0	65/1	0	0	1696	0.33	3300	6.82	1.08	3.71
SXGA	1280 × 1024	63.98	108.00	400	1	0	65/1	0	0	1688	0.33	3300	6.83	1.09	3.72
SXGA	1280 × 1024	79.98	135.00	400	1	0	65/1	0	0	1688	0.33	3300	6.83	1.09	3.72
SXGA	1280 × 1024	91.15	156.96	400	1	0	65/1	0	0	1722	0.33	3300	6.76	1.08	3.68

CLK Jitter Evaluation Method

The regenerated CLK is obtained by applying Hsync to the CXA3106AQ. Apply this CLK to a digital oscilloscope and observe the CLK waveform using Hsync as the trigger.

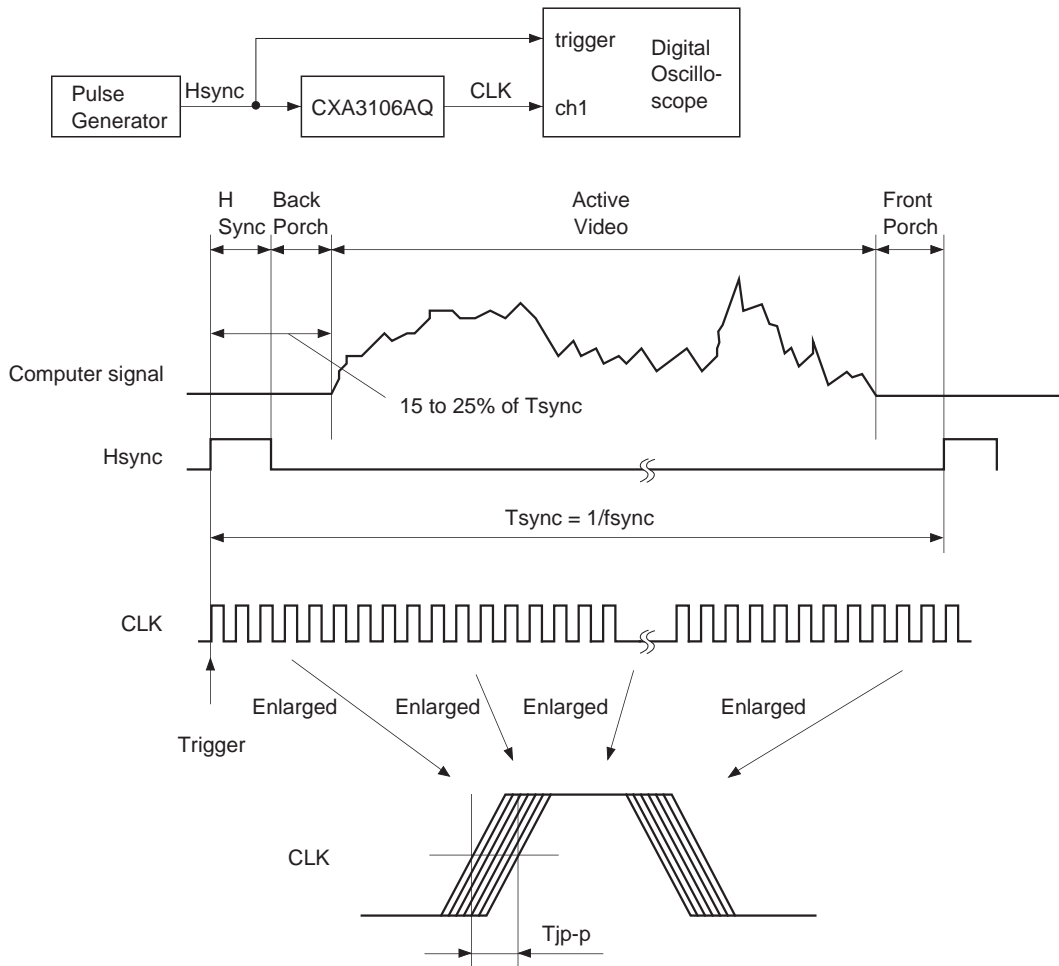

The CLK jitter is measured at peak to peak in the long-term write mode of the digital oscilloscope as shown in the figure. The CLK jitter size varies according to the difference in the relative position with respect to Hsync. Therefore, when the observation point is changed, the CLK jitter at that point is observed.

The figure below shows an typical example of the CLK jitter for the CXA3106AQ. The CLK jitter increases slightly at the rising edge of Hsync (in the case of positive polarity), and then settles down thereafter. However, this is not a problem as the active pixels start after about 20% of the H cycle has passed from the rising edge of Hsync.

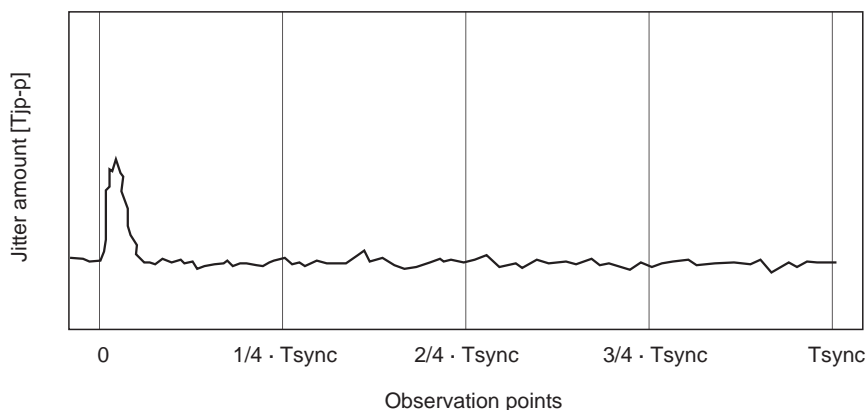

Example of Representative Characteristics

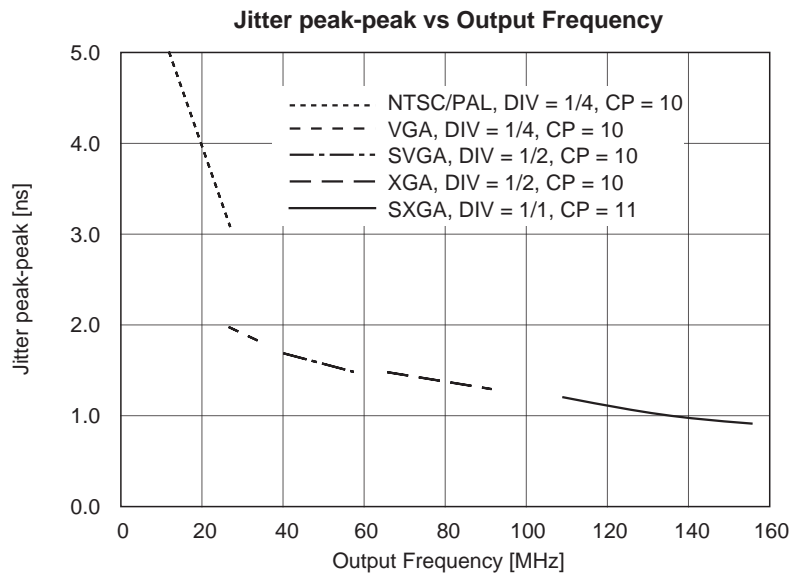
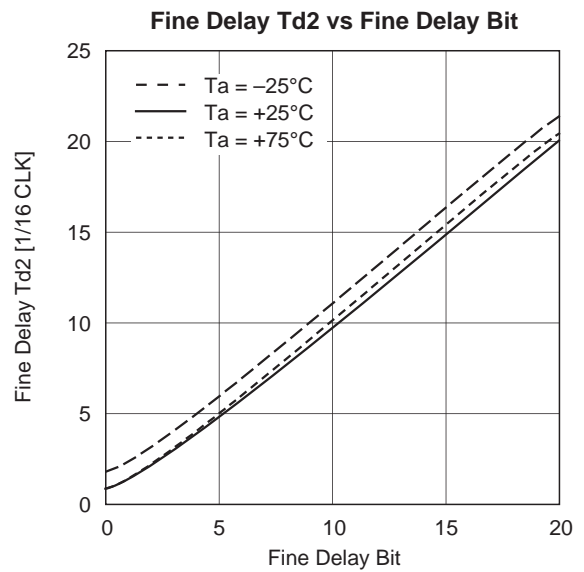
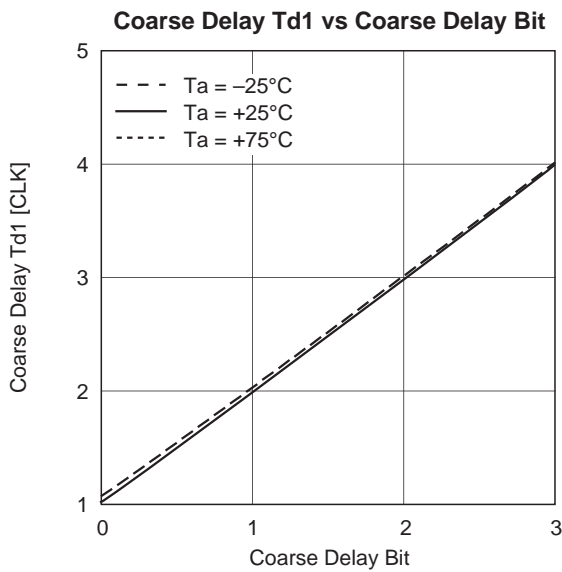
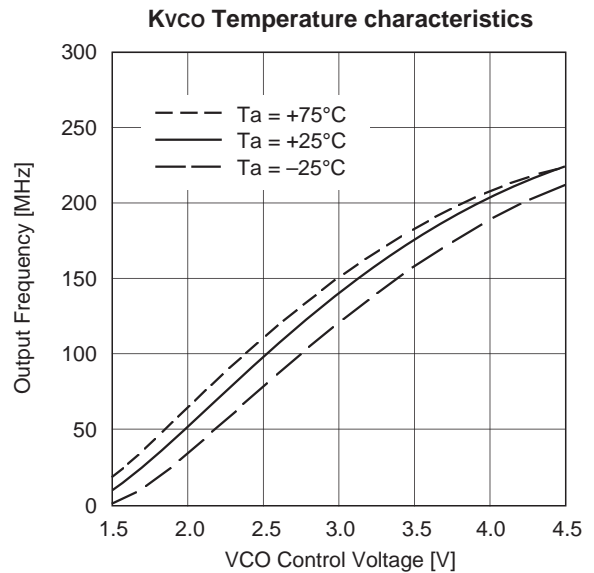
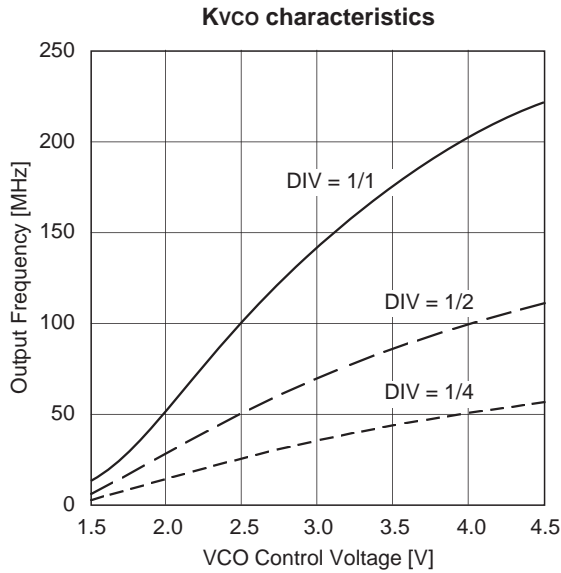

Notes on Operation

- Be sure not to separate the analog and digital power supplies, and the analog and digital GND.
- The ground pattern should be as wide as possible. Using a multi-layer substrate with a mat ground is recommended.
- Ground the power supply pins of the IC with a 0.1 μ F or larger ceramic chip capacitor as close to each pin as possible.
- Be sure to accurately match the I/O characteristic impedance in order to ensure sufficient performance during high-speed operation.
- Design the set so that the loop filter (external) is located at the minimum distance. (See the CXA3106AQ PWB.)

(1) Recommended PECL I/O circuit

The peripheral circuits mainly use PECL for digital input and output. Of course, PECL and TTL can also be mixed. In this case, disable the TTL outputs with the control registers.

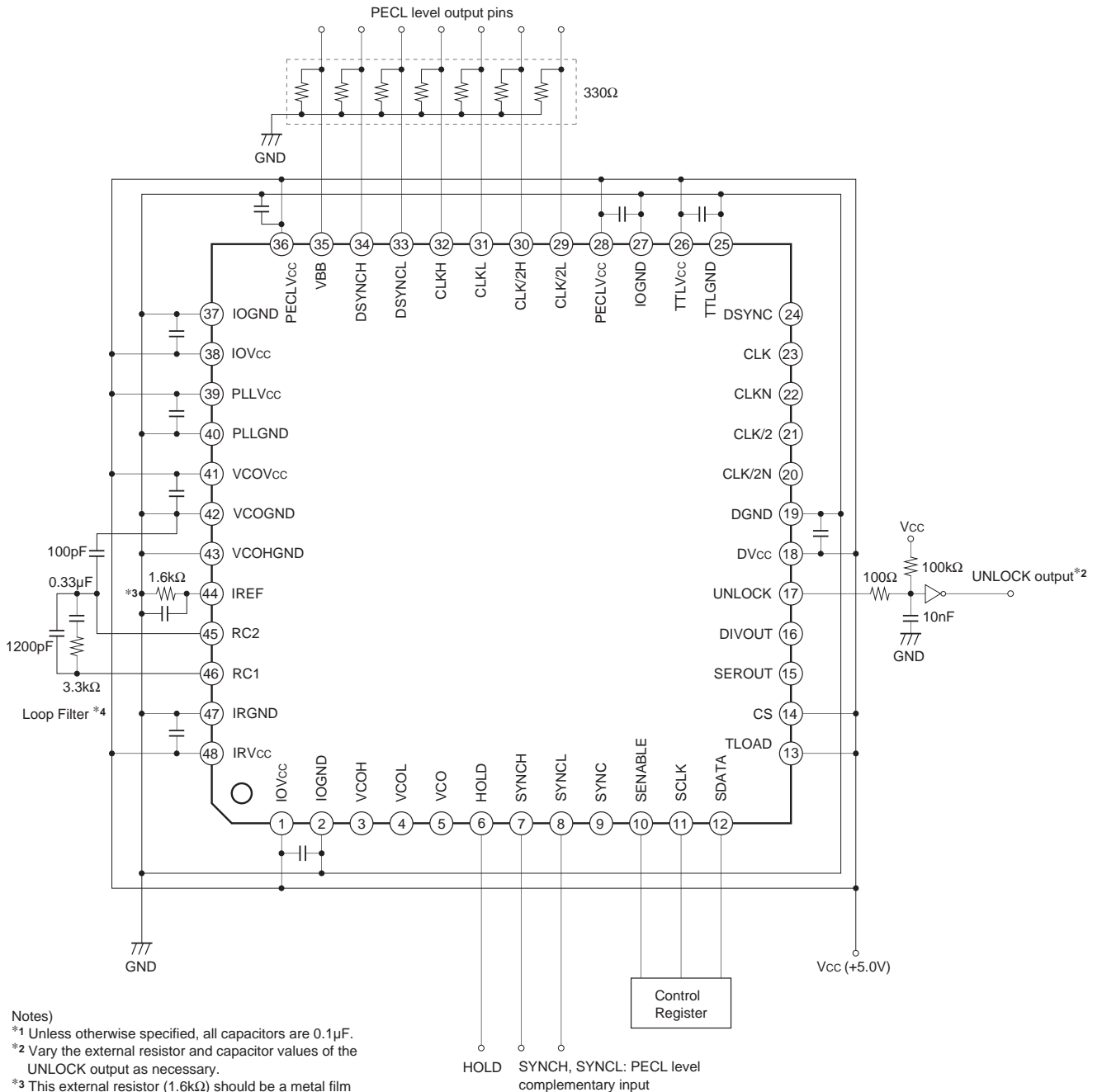

- Notes)
- *1 Unless otherwise specified, all capacitors are 0.1μF.
 - *2 Vary the external resistor and capacitor values of the UNLOCK output as necessary.
 - *3 This external resistor (1.6kΩ) should be a metal film resistor in consideration of temperature characteristics.
 - *4 The loop filter's capacitors and resistor should also be temperature compensated.

(2) Recommended TTL I/O circuit

The peripheral circuits mainly use TTL for digital input and output. Of course, PECL and TTL can also be mixed.

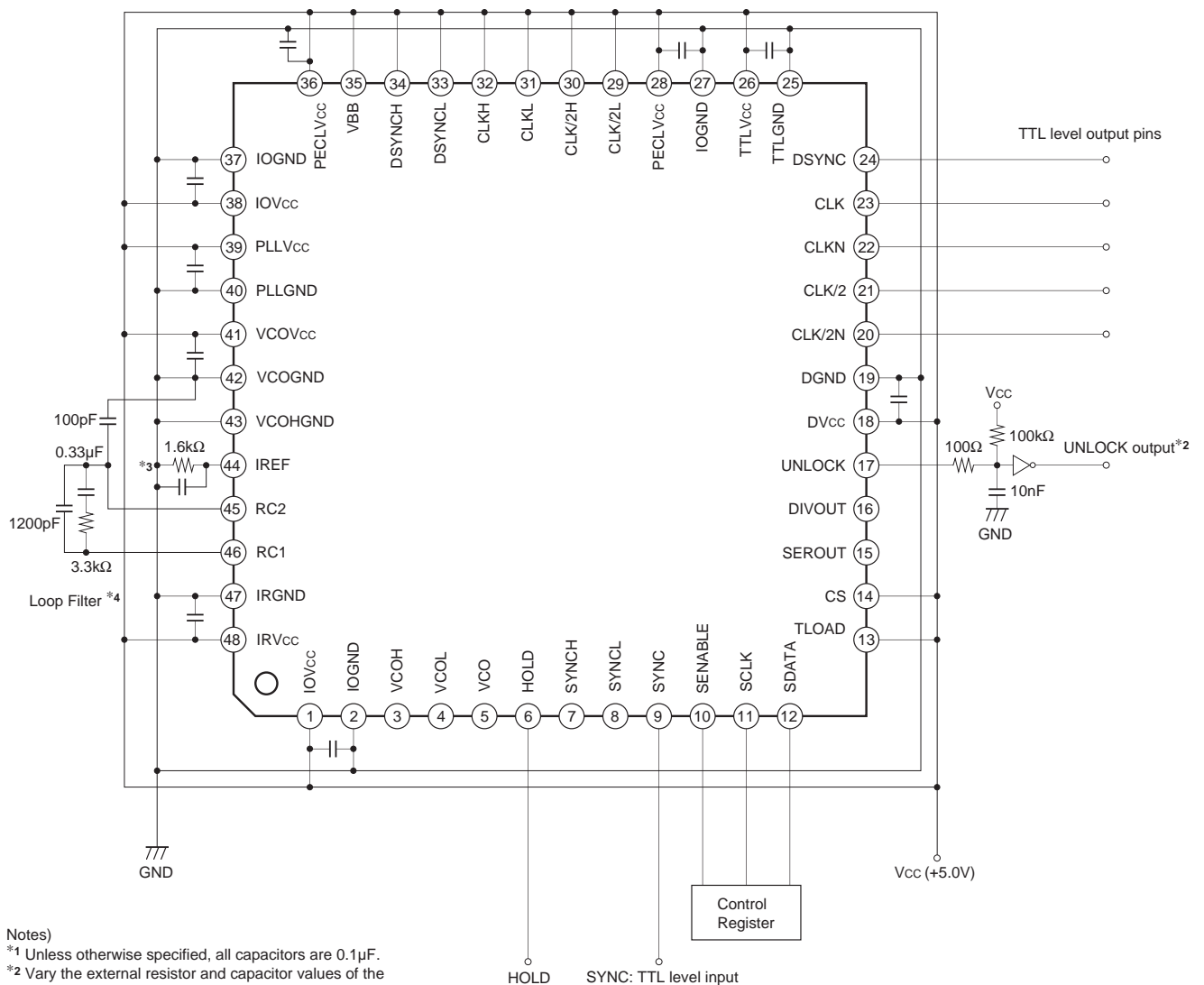

Notes)

- *1 Unless otherwise specified, all capacitors are 0.1μF.
- *2 Vary the external resistor and capacitor values of the UNLOCK output as necessary.
- *3 This external resistor (1.6kΩ) should be a metal film resistor in consideration of temperature characteristics.
- *4 The loop filter's capacitors and resistor should also be temperature compensated.

Connecting the CXA3106AQ with Sony ADC (Demultiplex Mode)

When connecting the PLL output to A/D converters with built-in demultiplex function such as the CXA3026AQ/CXA3026Q/CXA3086Q (Sony), a simple system can be configured by connecting the CLK (PECL) and CLKN (PECL) outputs of the CXA3106AQ to the CLK (PECL) and CLKN (PECL) inputs of each A/D converter, respectively, and the 1/2 CLK (PECL) and 1/2 CLKN (PECL) outputs of the CXA3106AQ to the RESETN (PECL) and RESET (PECL) inputs of each A/D converter, respectively. (when the PLL counter value N is an even number)

Wiring Diagram

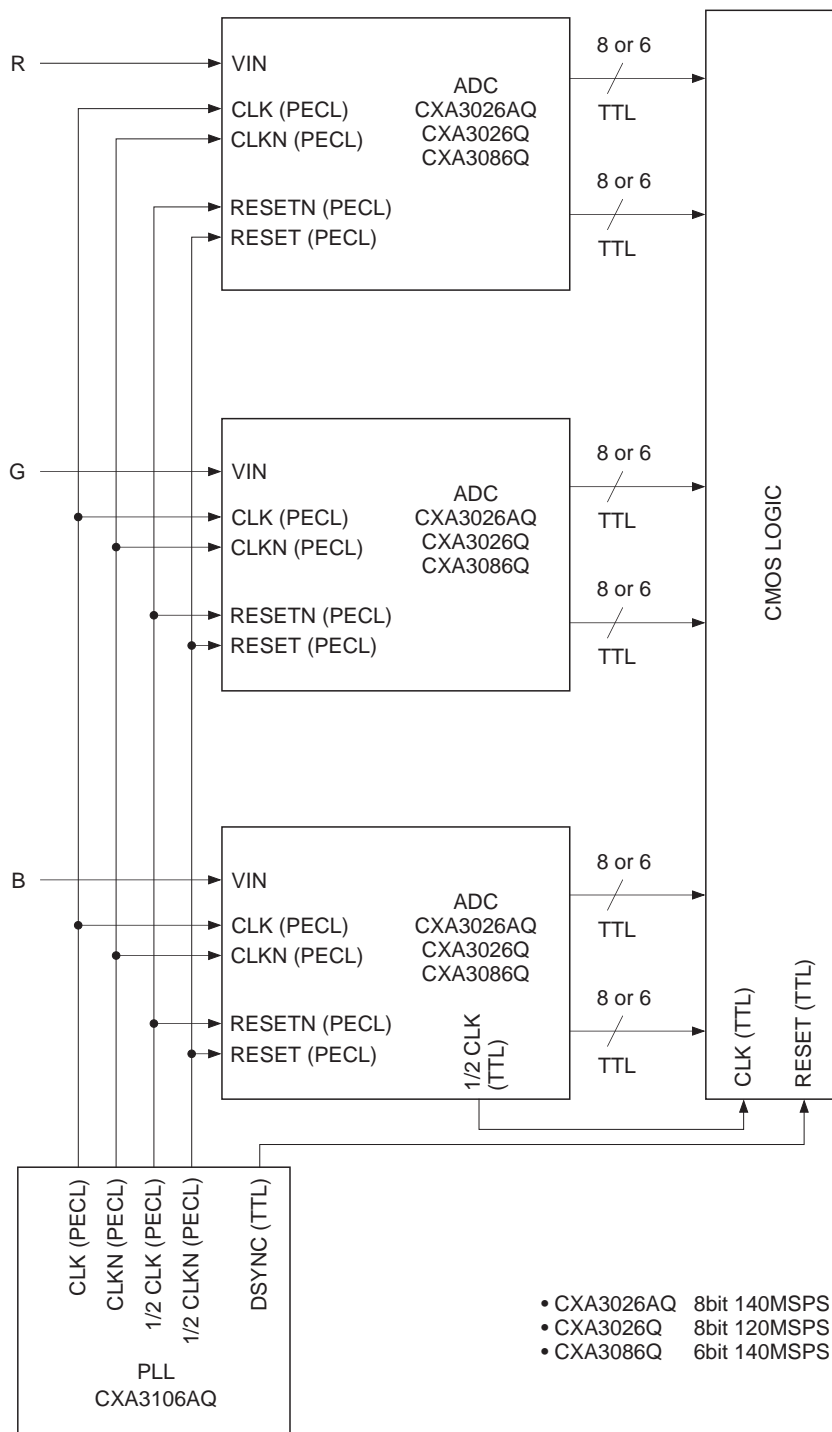

CXA3106AQ and Sony ADC (Demultiplex Mode) Timing

The CXA3106AQ and CXA3026Q/CXA3026AQ/CXA3086Q timings are shown below.

Here, the important timings are as follows.
(The clock cycle is labeled as T.)

- Within the A/D converters
Clock input vs. reset input
The setup time is T-1ns and the hold time is 0ns, satisfying the A/D converter specifications.
- Within the CMOS LOGIC at the rear end of the A/D converters
A/D converter data output vs. 1/2 clock output timing
The setup time is T-4.5ns and the hold time is T-0.5ns. (These timings also include combinations of three A/D converters from different lots, and are defined for all operating temperatures and all operating supply voltages. See the CXA3026Q/CXA3026AQ/CXA3086Q specifications for a detailed description.)
- Within the CMOS LOGIC at the rear end of the A/D converters
DSYNC signal from CXA3106AQ vs. A/D converter 1/2 clock output
The setup time is T-3ns and the hold time is T-5ns.

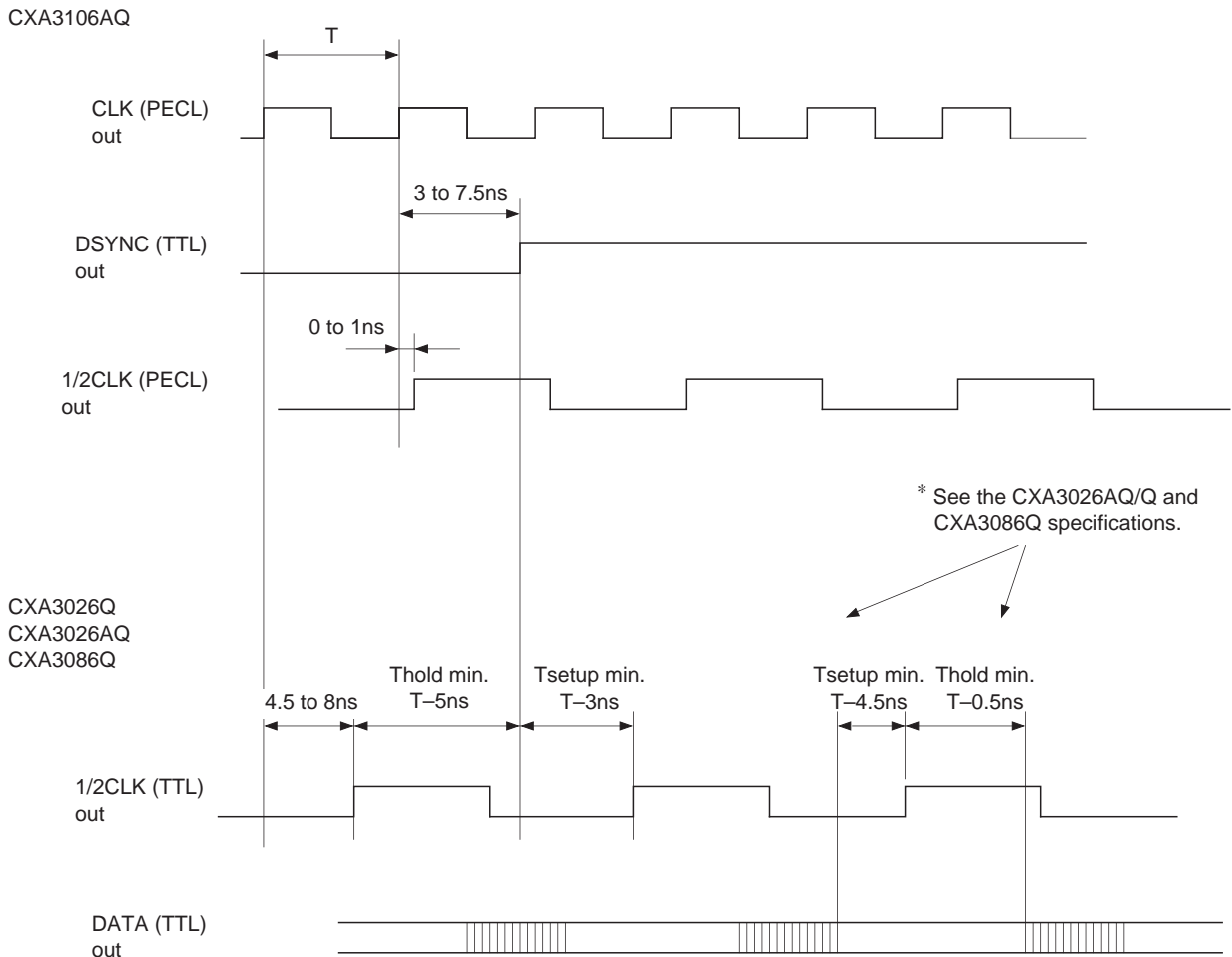

Connecting the CXA3106AQ with Sony ADC (Straight Mode)

When connecting the PLL output to A/D converters such as the CXA3026AQ/CXA3026Q/CXA3086Q (Sony), a simple system can be configured as shown below.

Wiring Diagram

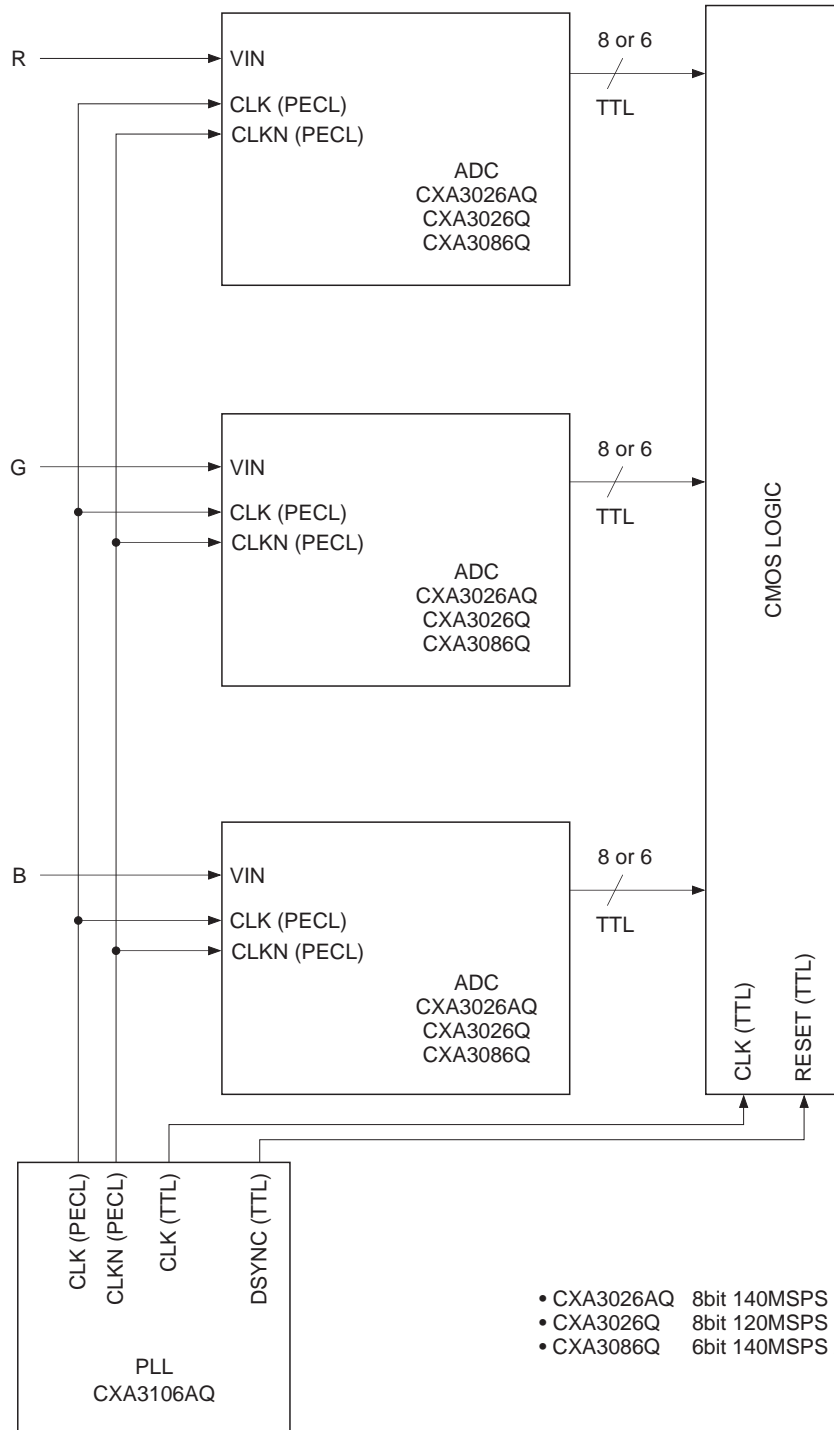

- CXA3026AQ 8bit 140MSPS ADC
- CXA3026Q 8bit 120MSPS ADC
- CXA3086Q 6bit 140MSPS ADC

CXA3106AQ and Sony ADC (Straight Mode) Timing

The CXA3106AQ and CXA3026Q/CXA3026AQ/CXA3086Q timings are shown below.

Here, the important timings are as follows.

(The clock cycle is labeled as T.)

- Within the CMOS LOGIC at the rear end of the A/D converters
A/D converter data output vs. clock output from CXA3106AQ
The setup time is $T-8.5\text{ns}$ and the hold time is 2ns . (These timings also include combinations of three A/D converters from different lots, and are defined for all operating temperatures and all operating supply voltages. See the CXA3026Q/CXA3026AQ/CXA3086Q specifications for a detailed description.)
- Within the CMOS LOGIC at the rear end of the A/D converters
DSYNC signal from CXA3106AQ vs. clock output from CXA3106AQ
The setup time is $T-4.5\text{ns}$ and the hold time is 1.5ns .

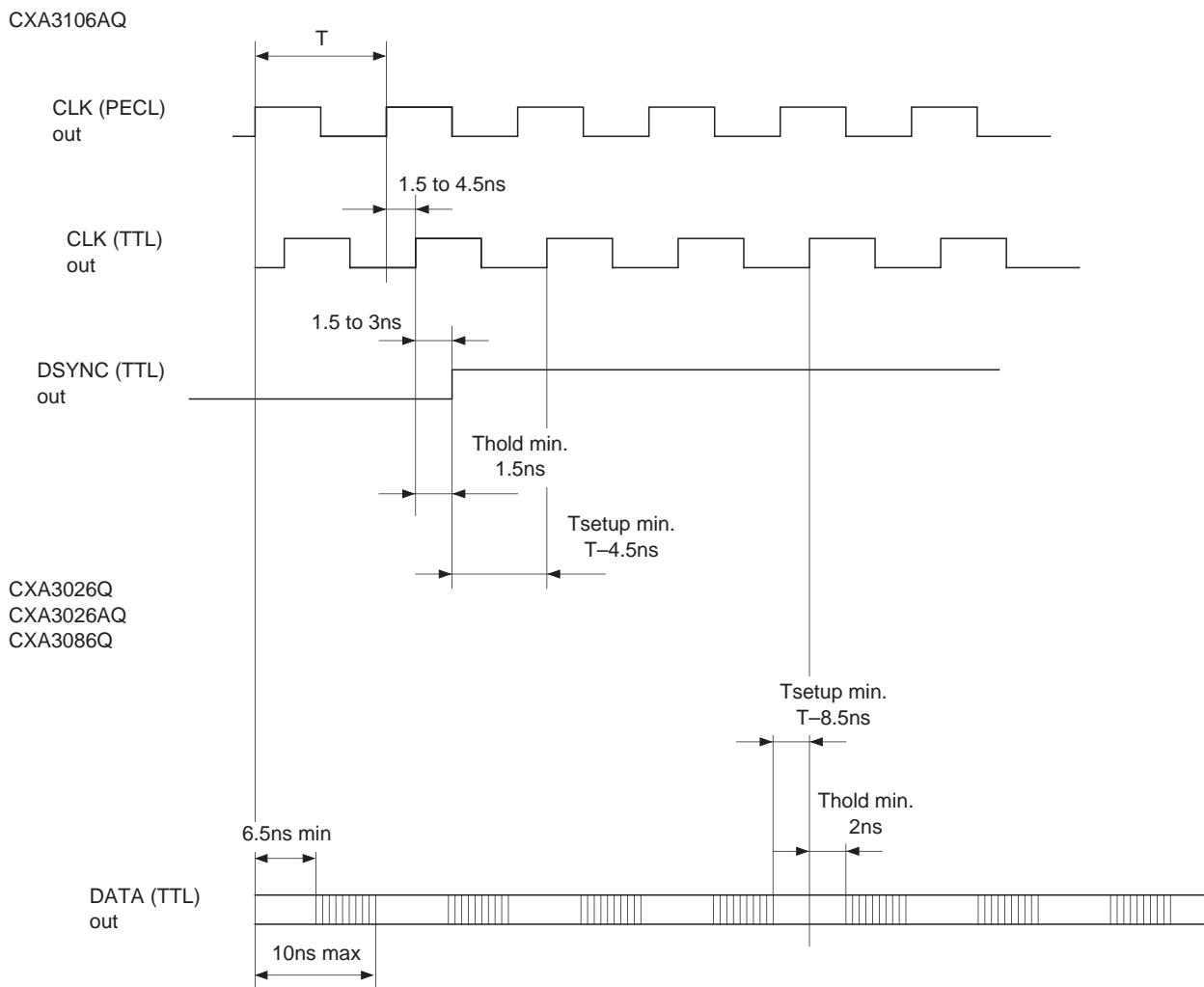

CXA3106AQ-PWB (CXA3106AQ Evaluation Board)

The CXA3106AQ-PWB is an evaluation board for the CXA3106AQ PLL-IC. This board makes it possible to easily evaluate the CXA3106AQ's performance using the supplied control program (Note: IBM PC/AT, MS-DOS 5.0 and newer US mode specifications).

Features

- Two input level (TTL and PECL) SYNC input
- Two output level (TTL and PECL) CLK, CLK2 and DSYNC output
- Supply voltage: +5.0V

Absolute Maximum Ratings (Ta = 25°C)

Supply voltage	V _{cc}	-0.5 to +7.0	V
----------------	-----------------	--------------	---

Recommended Operating Conditions

• Supply voltage	V _{cc}	4.75 to 5.25	V
	GND	0	V
• Digital input	(PECL)	DIN (High)	V _{cc} - 1.1 V (Min.)
		DIN (Low)	V _{cc} - 1.5 V (Max.)
	(TTL)	DIN (High)	GND + 2.0 V (Min.)
		DIN (Low)	GND + 0.8 V (Max.)
• Operating ambient temperature	T _a	-20 to +75	°C

Block Diagram

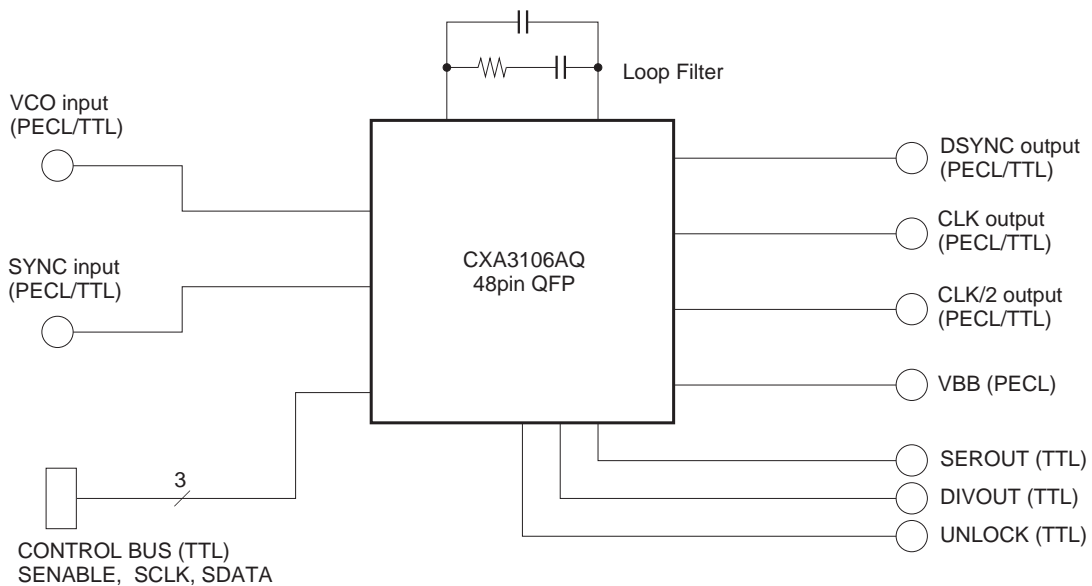

Setting Methods and Notes on Operation

Input pins

This PWB supports TTL single and PECL complementary input.

Input pins: SYNC: TTL level input, 10 to 100kHz
SYNCL: PECL low level input, 10 to 100kHz
SYNCH: PECL high level input, 10 to 100kHz

VCO: TTL level input. This is a test pin and is therefore normally not used.
VCOL: PECL low level input. This is a test pin and is therefore normally not used.
VCOH: PECL high level input. This is a test pin and is therefore normally not used.

Output pins

This PWB supports TTL single and PECL complementary output.

DSYNCH,
DSYNCL: PECL level complementary delay SYNC outputs. The output range is 10 to 160kHz.

DSYNC: TTL level delay SYNC output. The output range is 10 to 100kHz.

CLKH,
CLKL: PECL level complementary CLK outputs. The output range is 10 to 160MHz.

CLK,
CLKN: TTL level complementary CLK outputs. The output range is 10 to 80MHz.

CLK/2H,
CLK/2L: PECL level complementary 1/2 CLK outputs. The output range is 5 to 80MHz.

CLK/2,
CLK/2N: TTL level complementary CLK outputs. The output range is 5 to 80MHz.

VBB: Outputs the PECL amplitude threshold voltage.

SEROUT: TTL level control register serial data output.

DIVOUT: TTL level internal programmable counter test output.

UNLOCK: TTL level UNLOCK output. This pin requires external circuits such as appropriate capacitors and resistors.

See the IC specifications for a detailed description.

PECL outputs (VBB, DSYNCH, DSYNCL, CLKH, CLKL, CLK/2H, CLK/2L) are output constantly, but TTL outputs (DSYNC, CLK, CLKN, CLK/2, CLK/2N, SEROUT, DIVOUT, UNLOCK) are controlled by the respective control registers. Therefore, the enable/disable settings should be made in accordance with the application. See the following pages for the setting method.

Jumper Wire Settings

S1, S2: These enable/disable HOLD (Pin 6). HOLD is active high, so the jumper wire should be connected to S2 (HOLD = low) for normal use. When using HOLD, connect the jumper wire to S1 (HOLD = high). (For the initial setting, the jumper wire is connected to S2.)

S3, S4: These enable/disable TLOAD (Pin 13). Connect the jumper wire to S4 (TLOAD = high) for normal use. When using TLOAD, connect the jumper wire to S3 (TLOAD = low). (For the initial setting, the jumper wire is connected to S4.)

S5, S6: These enable/disable CS (Pin 14). Connect the jumper wire to S6 (CS = high) for normal use. When using Power Save, connect the jumper wire to S5 (CS = low). (For the initial setting, the jumper wire is connected to S6.)

Supplied Program

This PWB is equipped with a control program that facilitates evaluation of the CXA3106AQ. Operation methods and precautions are as follows.

1) Compatible personal computers

Use an IBM PC/AT or compatible machine equipped with a 25-pin D-SUB parallel port (printer port). Also, operating systems which support the program are MS-DOS 5.0 or newer and MS-Windows 3.1 or newer. (When using Windows, start the program from the DOS window.)

2) Connect the supplied cable

Connect the supplied cable to the parallel port of the personal computer and the DBUS1 connector of the CXA3106AQ-PWB.

D-SUB 25-pin parallel connector pin arrangement

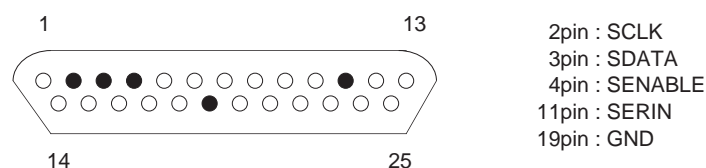

3) Connect the power cable and supply power to the CXA3106AQ-PWB

4) Start the program

A) Boot the personal computer and then shift to the directory containing the program.

B) Set MS-DOS to US mode. → US Return or Enter

C) Input the program name. → *1CXA3106A or CXA3106B Return or Enter → Move to the program screen.

*1 Only one of either CXA3106A or CXA3106B can be used as the program name depending on the printer port setting of the personal computer.

5) Description of the program screen

A) When the program is started, the following initial screen is displayed.

Please type the name of the initialization file OR press ENTER.
The file extension.INI should not be included. The default file
when ENTER is pressed is CXA3106.INI

Filename > _

When this screen appears, press the Return or Enter key. The screen shifts to the function setting screen.

B) Function settings

When the program is loaded, the following function setting screen appears.

```

                                CXA3106 PLL REGISTERS
                                Divisor 1344
                                Divider 2
                                Coarse Delay 00
                                Fine Delay 10
                                Charge Pump 10
                                Polarity
                                Power
                                SYNC  DSYNC  PD          SCAN  SYNTH          VCO Bypass
                                1      1      1          OFF   ON              ON
                                O/P Enable
                                DIVOUT  UNLOCK  DSYNC  CLK2  NCLK2  CLK1  NCLK1
                                OFF      OFF     OFF    OFF   OFF    OFF  OFF

```

Use arrow keys to select data bit. Press ENTER to toggle and load data.

Use Pg Up and Pg Dn to increment/decrement divisor and fine delay registers.

Press a to abort, s to scan registers

MIXED SIGNAL SYSTEMS JAN 1997

Divisor

This is used to input the frequency division ratio of the program counter. The value can be changed as desired from 9 to 4111 by moving the cursor to the position of the number and pressing the Return or Enter key. (Note: The operating range of the CXA3106AQ is from 256 to 4096.) The value can also be incremented or decremented by one step by pressing the Page Up or Page Down key, respectively.

The internal VCO has an oscillator frequency of 40 to 160MHz, so the output frequency and Divider (VCO frequency divider) setting range are as follows.

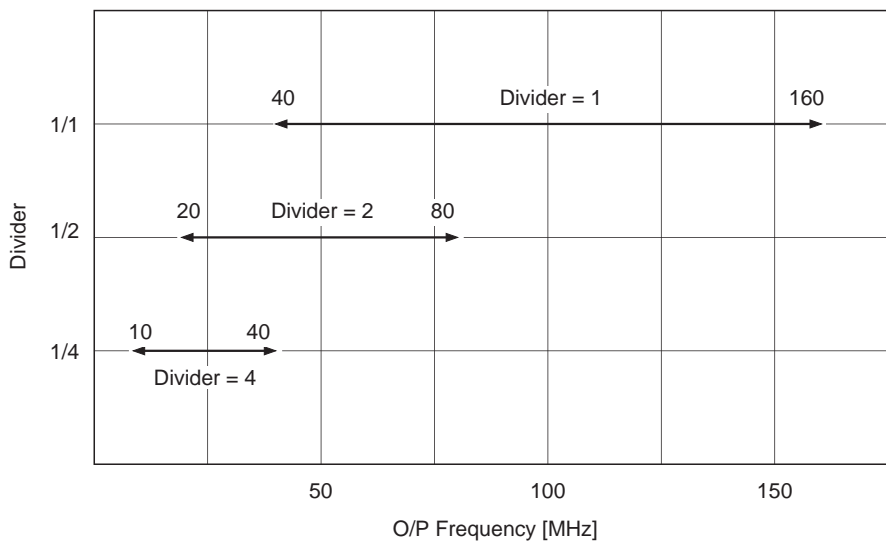

Divider

This sets the VCO output frequency division ratio to 1/1, 1/2 or 1/4. The frequency division ratio changes repeatedly in the order of 1/1 → 1/2 → 1/4 → 1/1 each time the cursor is moved to the position of the number and the Return or Enter key is pressed.

Coarse Delay

This is the DSYNC upper delay time setting. The value can be changed by moving the cursor to the position of the number and pressing the Return or Enter key. The delay time variable range settings are "00" (1 CLK), "01" (2 CLK), "10" (3 CLK) or "11" (4 CLK).

Fine Delay

This is the DSYNC lower delay time setting. The value can be changed by moving the cursor to the position of the number and pressing the Return or Enter key. The value can also be incremented or decremented by one step by pressing the Page Up or Page Down key, respectively. The delay time can be varied from 1/16 CLK to 32/16 CLK by setting "0" to "31", respectively.

Charge Pump

This is the charge pump circuit KI setting. The value can be changed by moving the cursor to the position of the number and pressing the Return or Enter key. KI can be set to "00" (about 100µA), "10" (about 400µA) or "11" (about 1.6mA).

The setting "01" is not used. (Setting "01" is the same as setting "00".)

Polarity

These are the SYNC, DSYNC and PD (Phase Detector) polarity inversion settings, and should be set as necessary such as when inverting the SYNC input and DSYNC output waveforms. The setting value "1" is positive polarity, and "0" is negative polarity. These should normally all be set to "1". (Fix PD to "1" other than during test mode.)

Power

SCAN: This is the control register read setting. When this is ON, the control register serial data is output from SEROUT (Pin 15). This should normally be set to OFF.

SYNTH: This is the enable/disable setting for this IC. This should normally be set to ON.

VCO Bypass: This is set to OFF when testing the program counter. This should normally be set to ON.

O/P Enable

These are the enable/disable settings for each TTL output (DIVOUT, UNLOCK, DSYNC, CLK2, NCLK2, CLK1 and NCLK1). Set to ON when performing evaluation using TTL output.

C) Description of readout mode

This program has a function (readout mode) that reads the contents written to the control registers from the CXA3106AQ SEROUT (Pin 15) and displays these contents on the screen. This function is described below.

- 1) Set SCAN to ON at the function setting screen.
- 2) Press the S key.

The following screen appears.

```
                SCAN RESULT, CXA3106 PLL REGISTERS
Register 1 DIVREG1      00111000
Register 2 DIVREG2      0101
Register 3 CENFREREG    1011111
Register 4 DELAYREG     0010000
Register 5 CPREG        100
Register 6 TTLPOLREG    00000011
Register 7 TESTPOWREG   0111
```

Press r to return to PLL REGISTERS MENU.

Press a to abort

MIXED SIGNAL SYSTEMS AUG 1996

This screen conforms to the Control Register Table listed in the CXA3106AQ specifications.

- 3) Press the R key to return to the original function setting screen.

D) Quit the program

Press the A key to quit the program.

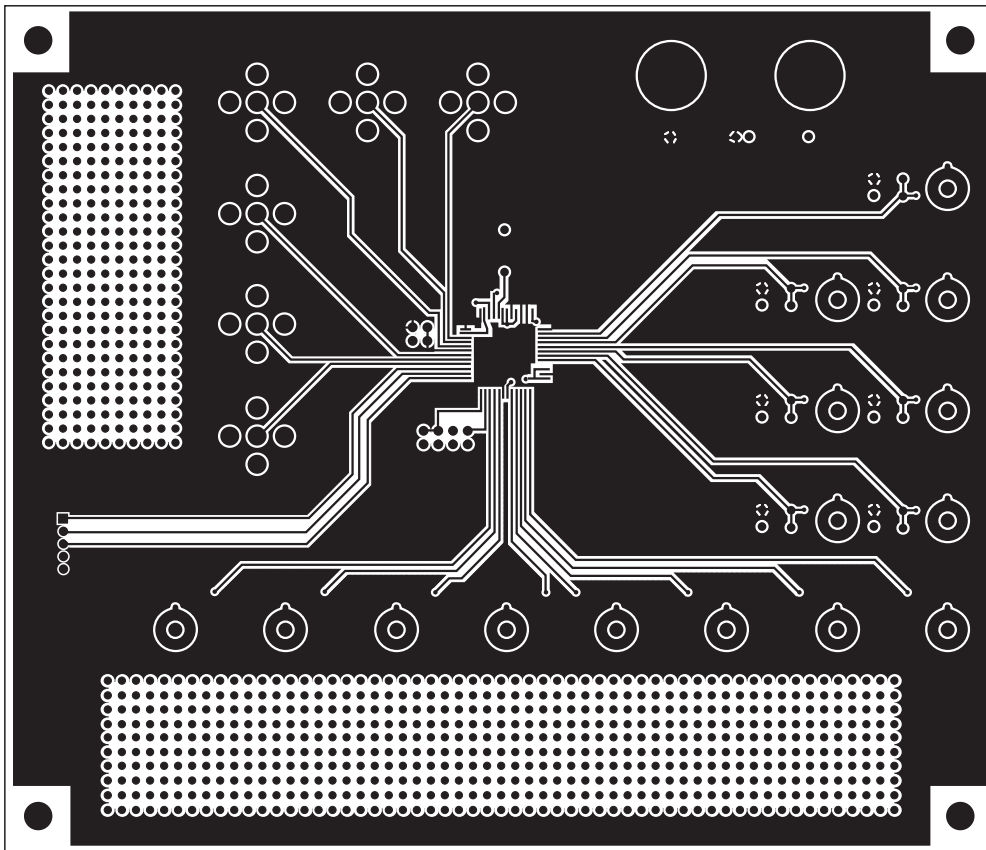

Substrate Pattern (parts surface)

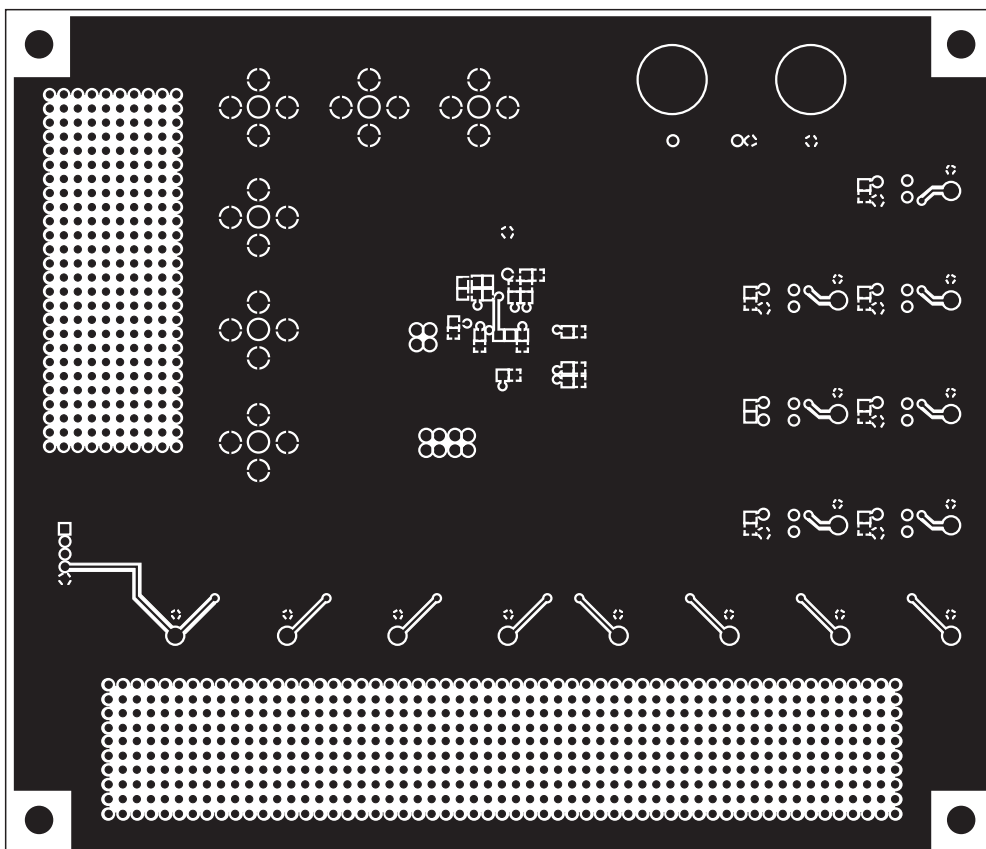

Substrate Pattern (solder surface)

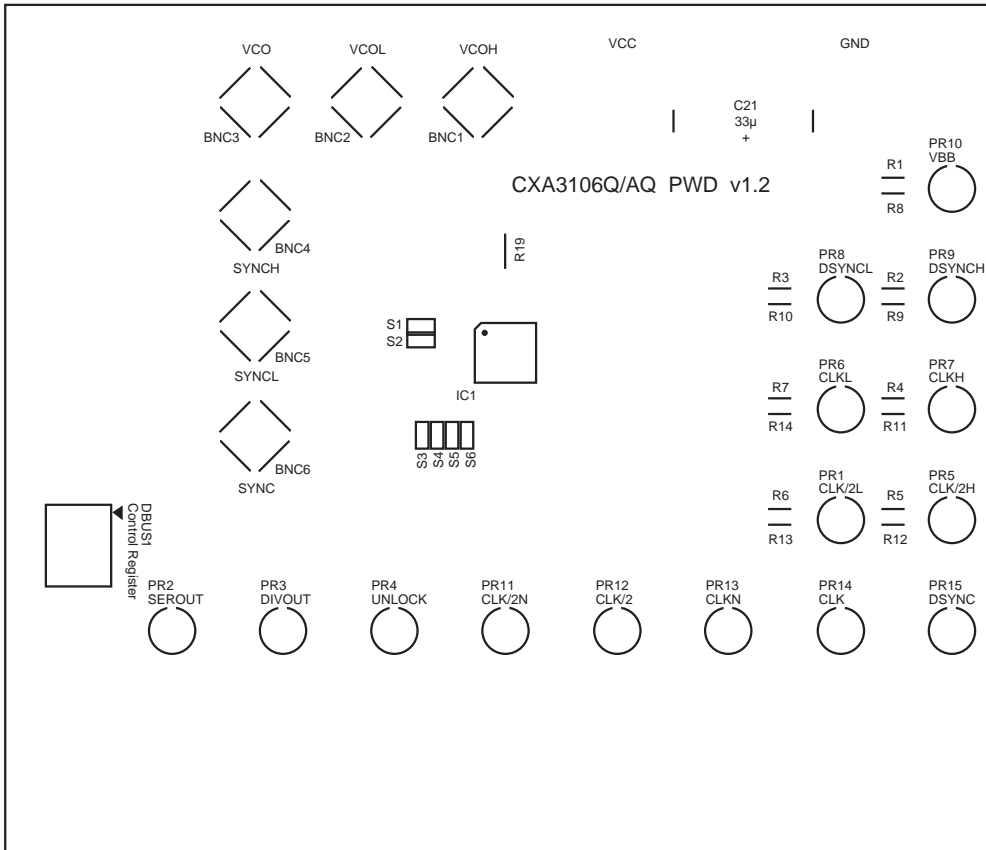

Silk Screen (parts surface)

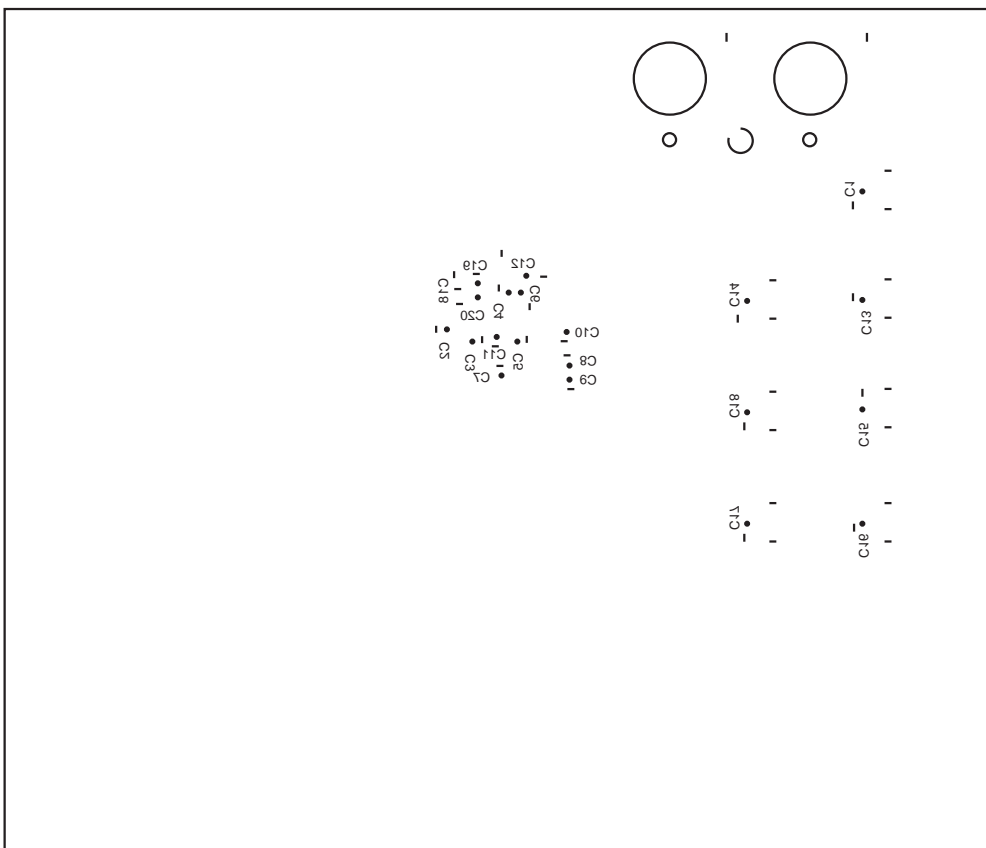

Silk Screen (solder surface)

Package Outline Unit: mm

48PIN QFP (PLASTIC)

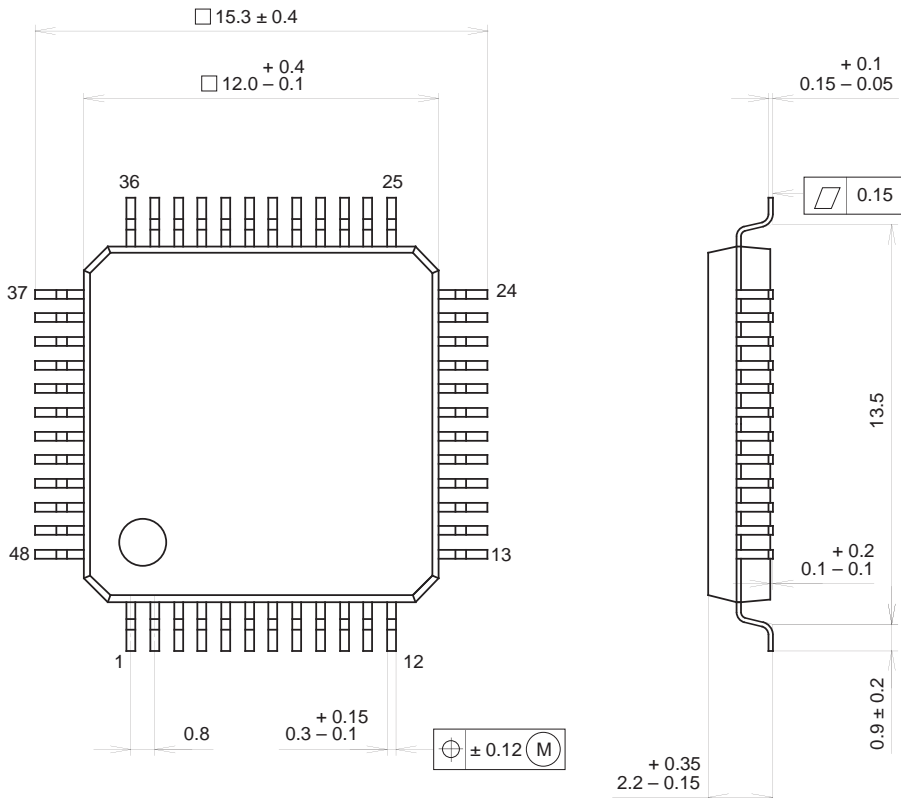

PACKAGE STRUCTURE

SONY CODE	QFP-48P-L04
EIAJ CODE	*QFP048-P-1212-B
JEDEC CODE	-----

PACKAGE MATERIAL	EPOXY RESIN
LEAD TREATMENT	SOLDER / PALLADIUM PLATING
LEAD MATERIAL	COPPER / 42 ALLOY
PACKAGE WEIGHT	0.7g

NOTE : PALLADIUM PLATING

This product uses S-PdPPF (Sony Spec.-Palladium Pre-Plated Lead Frame).