

Panasonic

Chip Resistor Array

Chip Resistor Array

- Type: **EXB1 : 0201 Array**
EXB2 : 0402 Array
EXB3 : 0603 Array
EXBN : 0402 Array
EXBV : 0603 Array
EXBS : 0805 Array

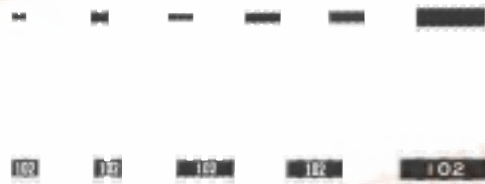

■ Features

- High density
 - 2 resistors in 0.8 mm × 0.6 mm size (EXB14V)
 - 4 resistors in 1.4 mm × 0.6 mm size (EXB18V)
 - 2 resistors in 1.0 mm × 1.0 mm size (EXB24V)
 - 4 resistors in 2.0 mm × 1.0 mm size (EXB28V, N8V)
 - 8 resistors in 3.8 mm × 1.6 mm size (EXB2HV)
 - 2 resistors in 1.6 mm × 1.6 mm size (EXB34V, V4V)
 - 4 resistors in 3.2 mm × 1.6 mm size (EXB38V, V8V)
 - 4 resistors in 5.1 mm × 2.2 mm size (EXBS8V)

- Improvement of placement efficiency

Placement efficiency of Chip Resistor Array is two, four or eight times of the flat type chip resistor

■ Explanation of Part Numbers

	1	2	3	4	5	6	7	8	9	10	11
	E	X	B	V	8	V	4	7	2	J	V

Product Code	Chip Resistor Array Type: inches	No. of Terminal	Schematics	Resistance Value	Resistance Tolerance	Packaging Methods								
Thick Film Chip Resistor Networks	1 0201 Array	4 4 Terminal	V Isolated type	The first two digits are significant figures of resistance value and the third one denotes the number of zeros following. Jumper is expressed by R00 Example: 222: 2.2 kΩ	J ±5 %	<table border="1" style="width: 100%; border-collapse: collapse;"> <thead> <tr> <th>Code</th> <th>Packaging</th> </tr> </thead> <tbody> <tr> <td>Nil</td> <td>Embossed Carrier Taping (S8V)</td> </tr> <tr> <td>X</td> <td>Punched Carrier Taping 2 mm pitch (14V, 18V, 24V, 28V, N8V)</td> </tr> <tr> <td>V</td> <td>Punched Carrier Taping 4 mm pitch (2HV, 34V, 38V, V4V, V8V)</td> </tr> </tbody> </table>	Code	Packaging	Nil	Embossed Carrier Taping (S8V)	X	Punched Carrier Taping 2 mm pitch (14V, 18V, 24V, 28V, N8V)	V	Punched Carrier Taping 4 mm pitch (2HV, 34V, 38V, V4V, V8V)
	Code	Packaging												
	Nil	Embossed Carrier Taping (S8V)												
	X	Punched Carrier Taping 2 mm pitch (14V, 18V, 24V, 28V, N8V)												
	V	Punched Carrier Taping 4 mm pitch (2HV, 34V, 38V, V4V, V8V)												
2 0402 Array	8 8 Terminal	0 Jumper												
3 0603 Array	H 16 Terminal													
N 0402 Array	Convex Terminal													
V 0603 Array	Concave Terminal													
S 0805 Array														

■ Construction (Example : Concave Terminal)

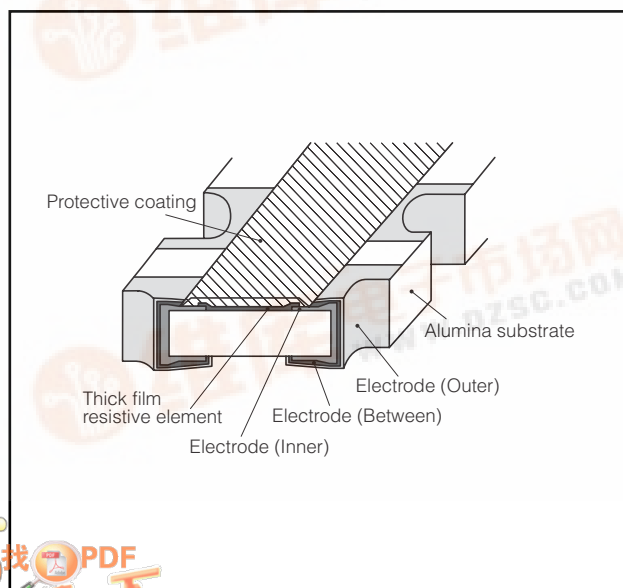

■ Schematics

- Isolated type

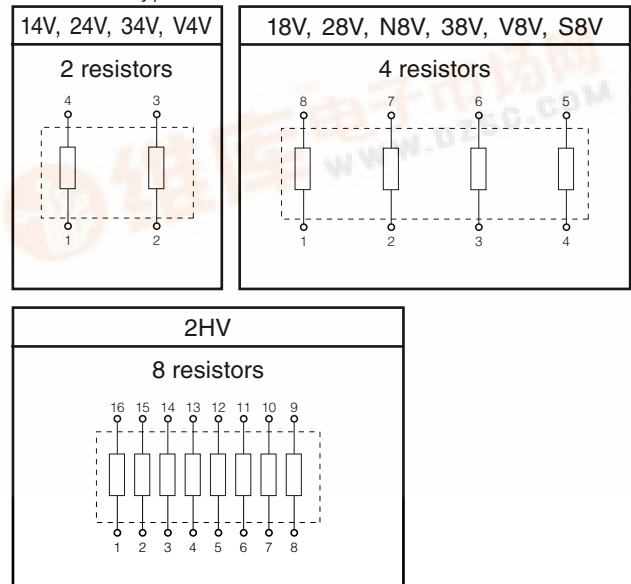

■ Dimensions in mm (not to scale)

(1) Convex Terminal type

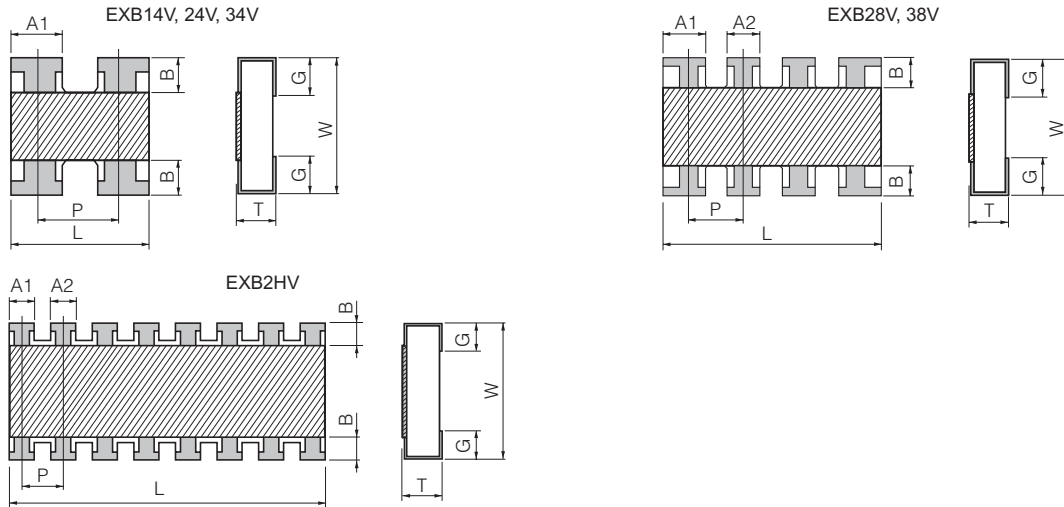

Type (inches)	Dimensions (mm)								Mass (Weight) [g/1000 pcs.]
	L	W	T	A1	A2	B	P	G	
EXB14V (0201×2)	0.80 ^{+0.10}	0.60 ^{+0.10}	0.35 ^{+0.10}	0.35 ^{+0.10}	—	0.15 ^{+0.10}	(0.50)	0.15 ^{+0.10}	0.5
EXB24V (0402×2)	1.00 ^{+0.10}	1.00 ^{+0.10}	0.35 ^{+0.10}	0.40 ^{+0.10}	—	0.18 ^{+0.10}	(0.65)	0.25 ^{+0.10}	1.2
EXB28V (0402×4)	2.00 ^{+0.10}	1.00 ^{+0.10}	0.35 ^{+0.10}	0.45 ^{+0.10}	0.35 ^{+0.10}	0.20 ^{+0.10}	(0.50)	0.25 ^{+0.10}	2.0
EXB2HV (0402×8)	3.80 ^{+0.10}	1.60 ^{+0.10}	0.45 ^{+0.10}	0.35 ^{+0.10}	0.35 ^{+0.10}	0.30 ^{+0.10}	(0.50)	0.30 ^{+0.10}	9.0
EXB34V (0603×2)	1.60 ^{+0.20}	1.60 ^{+0.15}	0.50 ^{+0.10}	0.65 ^{+0.15}	—	0.30 ^{+0.20}	(0.80)	0.30 ^{+0.20}	3.5
EXB38V (0603×4)	3.20 ^{+0.20}	1.60 ^{+0.15}	0.50 ^{+0.10}	0.65 ^{+0.15}	0.45 ^{+0.15}	0.30 ^{+0.20}	(0.80)	0.35 ^{+0.20}	7.0

() Reference

(2) Concave Terminal type

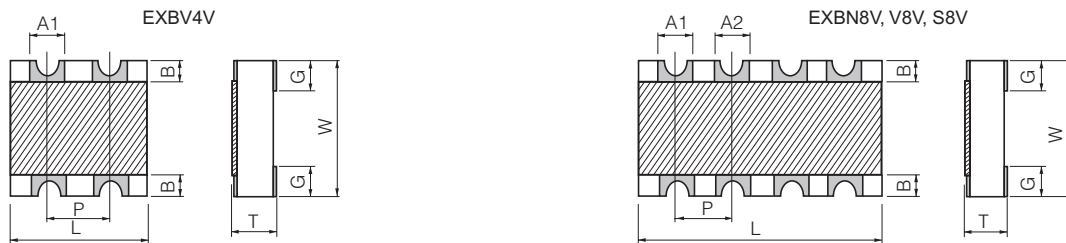

Type (inches)	Dimensions (mm)								Mass (Weight) [g/1000 pcs.]
	L	W	T	A1	A2	B	P	G	
EXBN8V (0402×4)	2.00 ^{+0.10}	1.00 ^{+0.10}	0.45 ^{+0.10}	0.30 ^{+0.10}	0.30 ^{+0.10}	0.20 ^{+0.15}	(0.50)	0.30 ^{+0.15}	3.0
EXBV4V (0603×2)	1.60 ^{+0.20} _{-0.10}	1.60 ^{+0.20} _{-0.10}	0.60 ^{+0.10}	0.60 ^{+0.10}	—	0.30 ^{+0.15}	(0.80)	0.45 ^{+0.15}	5.0
EXBV8V (0603×4)	3.20 ^{+0.20} _{-0.10}	1.60 ^{+0.20} _{-0.10}	0.60 ^{+0.10}	0.60 ^{+0.10}	0.60 ^{+0.10}	0.30 ^{+0.15}	(0.80)	0.45 ^{+0.15}	10
EXBS8V (0805×4)	5.08 ^{+0.20} _{-0.10}	2.20 ^{+0.20} _{-0.10}	0.70 ^{+0.20}	0.80 ^{+0.15}	0.80 ^{+0.15}	0.50 ^{+0.15}	(1.27)	0.55 ^{+0.15}	30

() Reference

(3) Flat Terminal type

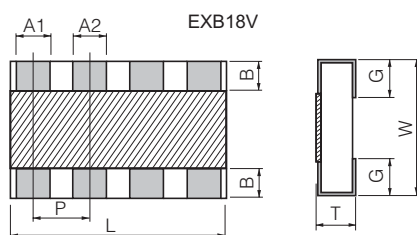

Type (inches)	Dimensions (mm)								Mass (Weight) [g/1000 pcs.]
	L	W	T	A1	A2	B	P	G	
EXB18V (0201×4)	1.40 ^{+0.10}	0.60 ^{+0.10}	0.35 ^{+0.10}	0.20 ^{+0.10}	0.20 ^{+0.10}	0.10 ^{+0.10}	(0.40)	0.20 ^{+0.10}	1.0

() Reference

■ Ratings

Item		Specifications
Resistance Range		10 Ω to 1 MΩ: E24 series
Resistance Tolerance		J: ±5 %
Number of Terminals	14V,24V,V4V,34V	4 terminal
	18V,28V,N8V,38V,V8V,S8V	8 terminal
	2HV	16 terminal
Number of Resistors	14V,24V,V4V,34V	2 terminal
	18V,28V,N8V,38V,V8V,S8V	4 terminal
	2HV	8 terminal
Power Rating at 70 °C	14V,28V,N8V	0.031 W/element
	18V	0.031 W/element (0.1 W/package)
	24V,V4V,34V,V8V,38V	0.063 W/element
	S8V	0.1 W/element
	2HV	0.063 W/element (0.25 W/package)

Item		Specifications	
Limiting Element Voltage ⁽¹⁾ (Max. Rated Continuous Working Voltage)	14V,18V	12.5 V	
	2HV	25 V	
	24V,28V,N8V,38V,34V,V4V,V8V	50 V	
Max. Over-load Voltage ⁽²⁾	S8V	100 V	
	14V,18V	25 V	
	2HV	50 V	
	24V,28V,N8V,38V,34V,V4V,V8V	100 V	
S8V	200 V		
T.C.R.		±200×10 ⁻⁶ /°C(ppm/°C)	
Category Temperature Range (Operating Temperature Range)		-55 °C to 125 °C	
Jumper Array	Rated Current	14V,18V	0.5 A
		2HV,24V,28V,N8V,38V,34V,V4V,V8V	1 A
		S8V	2 A
	Max. Overload Current	14V,18V	1 A
		2HV,24V,28V,N8V,38V,34V,V4V,V8V	2 A
		S8V	4 A

(1) Rated Continuous Working Voltage (RCWV) shall be determined from $RCWV = \sqrt{\text{Power Rating} \times \text{Resistance Value}}$, or Limiting Element Voltage (max. RCWV) listed above, whichever less.

(2) Overload (Short-time Overload) Test Voltage (SOTV) shall be determined from $SOTV = 2.5 \times \text{Power Rating}$ or max. Overload (Voltage) listed above whichever less.

Power Derating Curve

For resistors operated in ambient temperature above 70 °C, power rating shall be derated in accordance with the figure on the right.

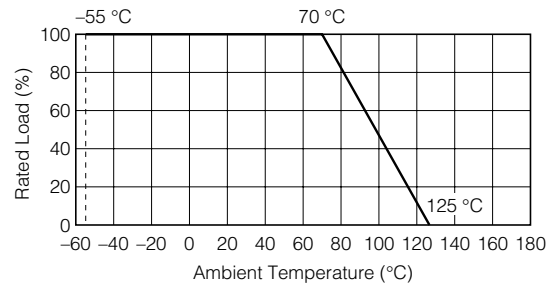

■ Packaging Methods (Taping)

- Standard Quantity

Type	Kind of Taping	Pitch (P ₁)	Quantity	
EXB14V, 18V	Punched Carrier Taping	2 mm	10000 pcs./reel	
EXB24V, 28V				
EXBN8V				
EXB2HV		4 mm		5000 pcs./reel
EXB34V, 38V				
EXBV4V, V8V				
EXBS8V	Embossed Carrier Taping		2500 pcs./reel	

● Carrier Tape

Unit (mm)

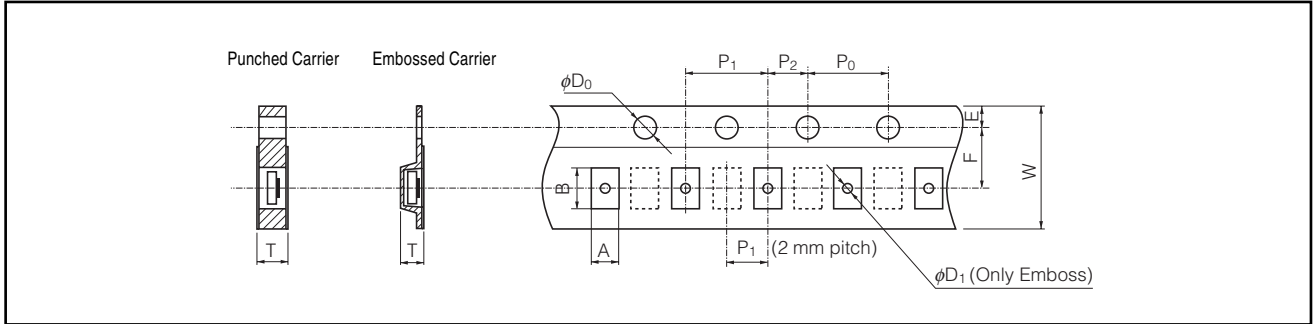

Type	A	B	W	F	E	P ₁	P ₂	P ₀	φD ₀	T	φD ₁
EXB14V	0.70 ^{+0.10} _{-0.05}	0.90 ^{+0.10} _{-0.05}	8.00 ^{±0.20}	3.50 ^{±0.05}	1.75 ^{±0.10}	2.00 ^{±0.10}	2.00 ^{±0.05}	4.00 ^{±0.10}	1.50 ^{+0.10} ₀	0.52 ^{±0.05}	-
EXB18V		1.60 ^{±0.10}									
EXB24V	1.20 ^{±0.10}	1.20 ^{±0.10}									
EXB28V		2.20 ^{±0.10}									
EXBN8V	1.95 ^{±0.15}	4.10 ^{±0.15}				4.00 ^{±0.10}	0.70 ^{±0.05}				
EXB2HV		1.95 ^{±0.20}									
EXB34V		3.60 ^{±0.20}									
EXB38V		1.95 ^{±0.20}									
EXBV4V	3.60 ^{±0.20}	0.84 ^{±0.05}									
EXBV8V		1.60 max.	1.50 ^{+0.10} ₀								
EXBS8V	2.80 ^{±0.20}	5.70 ^{±0.20}	12.00 ^{±0.30}	5.50 ^{±0.20}							

● Taping Reel

Unit (mm)

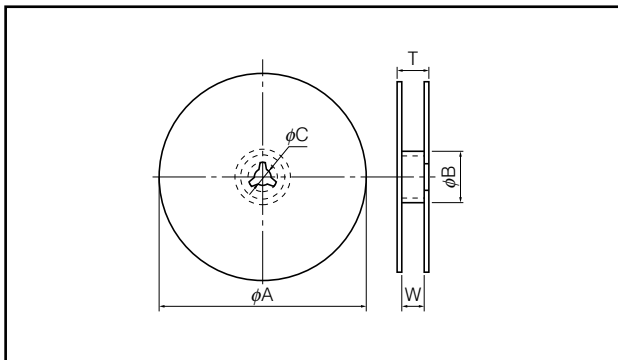

Type	φA	φB	φC	W	T
EXB14V,18V	180.0 ⁺⁰ _{-3.0}	60 min.	13.0 ^{±1.0}	9.0 ^{±1.0}	11.4 ^{±1.0}
EXB24V,28V					
EXBN8V					
EXB2HV					
EXB34V,38V				13.0 ^{±1.0}	15.4 ^{±2.0}
EXBV4V,V8V					
EXBS8V					

■ Land pattern design

Recommended land pattern design for Network chip is shown below.

The diagram shows a cross-section of a land pattern on a carrier tape. Dimensions are labeled: 'a' (height of the land), 'b' (width of the land), 'c' (width of the gap), 'p' (pitch between lands), and 'f' (height of the carrier tape).

(Not to scale)

Type	Dimensions				Unit (mm)
	a	b	c	p	f
14V	0.20 to 0.30	0.25 to 0.30	0.25 to 0.30	0.50	0.80 to 0.90
18V	0.20 to 0.30	0.15 to 0.20	0.15 to 0.20	0.40	0.80 to 0.90
24V	0.5	0.35 to 0.40	0.35 to 0.40	0.65	1.4 to 1.5
V4V,V8V	0.7 to 0.9	0.4 to 0.45	0.4 to 0.45	0.80	2 to 2.4
34V,38V	0.7 to 0.9	0.4 to 0.5	0.4 to 0.5	0.80	2.2 to 2.6
S8V	1 to 1.2	0.5 to 0.75	0.5 to 0.75	1.27	3.2 to 3.8

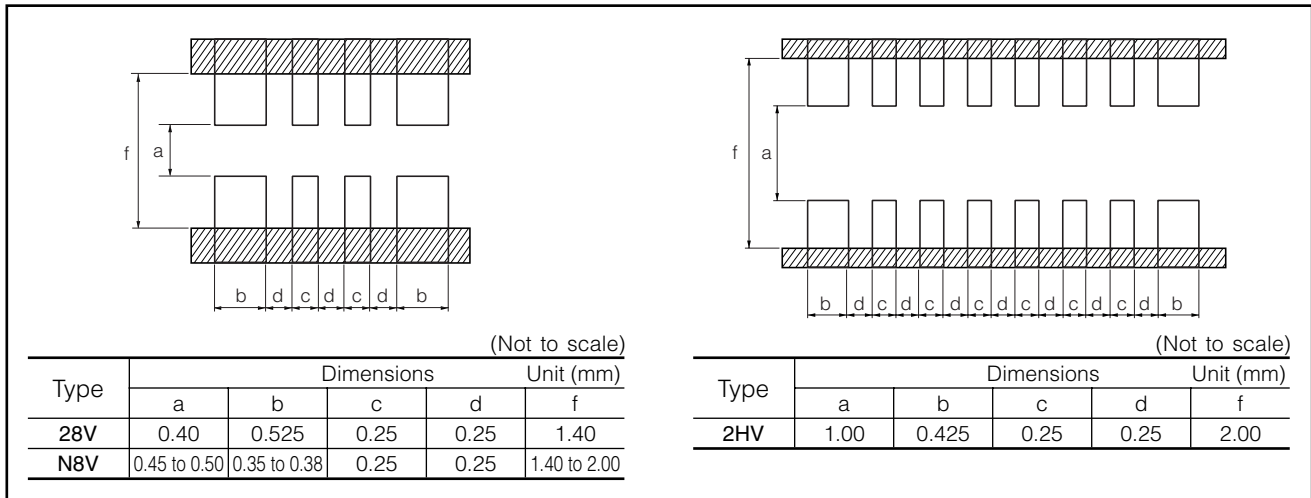

Recommended Soldering Conditions

Recommendations and precautions are described below.

Recommended soldering conditions for reflow

- Reflow soldering shall be performed a maximum of two times.
- Please contact us for additional information when used in conditions other than those specified.
- Please measure the temperature of the terminals and study every kind of solder and printed circuit board for solderability before actual use.

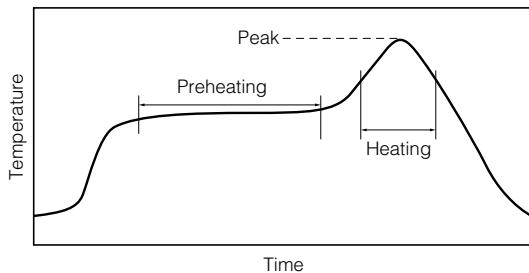

For soldering (Example : Sn/Pb)

	Temperature	Time
Preheating	140 °C to 160 °C	60 s to 120 s
Main heating	Above 200 °C	30 s to 40 s
Peak	235 ± 5 °C	max. 10 s

For lead-free soldering (Example : Sn/Ag/Cu)

	Temperature	Time
Preheating	150 °C to 180 °C	60 s to 120 s
Main heating	Above 230 °C	30 s to 40 s
Peak	max. 260 °C	max. 10 s

Flow soldering

- We do not recommend flow soldering, because a solder bridge may form.

⚠ Safety Precautions

The following are precautions for individual products. Please also refer to the precautions common to Fixed Resistors shown on page ER3 of this catalog.

1. Take measures against mechanical stress during and after mounting of Chip Resistor Array (hereafter called the resistors) so as not to damage their electrodes and protective coatings.
Be careful not to misplace the resistors on the land patterns. Otherwise, solder bridging may occur.
2. If a transient load (heavy load in a short time) like a pulse is expected to be applied, check and evaluate the operations of the resistors when installed in your products before use.
Never exceed the rated power. Otherwise, the performance and/or reliability of the resistors may be impaired.
3. Do not use halogen-based or other high-activity flux. Otherwise, the residue may impair the resistors' performance and/or reliability.
4. When soldering with a soldering iron, never touch the resistors' bodies with the tip of the soldering iron. When using a soldering iron with a high temperature tip, finish soldering as quickly as possible (within three seconds at 350 °C max.).
5. As the amount of applied solder becomes larger, the mechanical stress applied to the resistors increases, causing problems such as cracks and faulty characteristics. Avoid applying an excessive amounts of solder.
6. Do not apply shock to the resistors or pinch them with a hard tool (e.g. pliers and tweezers). Otherwise, the resistors' protective coatings and bodies may be chipped, affecting their performance.
7. Avoid excessive bending of printed circuit boards in order to protect the resistors from abnormal stress.

Panasonic

Safety Precautions

(Common precautions for Fixed Resistors)

- When using our products, no matter what sort of equipment they might be used for, be sure to make a written agreement on the specifications with us in advance. The design and specifications in this catalog are subject to change without prior notice.
- Do not use the products beyond the specifications described in this catalog.
- This catalog explains the quality and performance of the products as individual components. Before use, check and evaluate their operations when installed in your products.
- Install the following systems for a failsafe design to ensure safety if these products are to be used in equipment where a defect in these products may cause the loss of human life or other significant damage, such as damage to vehicles (automobile, train, vessel), traffic lights, medical equipment, aerospace equipment, electric heating appliances, combustion/gas equipment, rotating equipment, and disaster/crime prevention equipment.
- * Systems equipped with a protection circuit and a protection device
- * Systems equipped with a redundant circuit or other system to prevent an unsafe status in the event of a single fault

(1) Precautions for use

- These products are designed and manufactured for general and standard use in general electronic equipment (e.g. AV equipment, home electric appliances, office equipment, information and communication equipment)
- These products are not intended for use in the following special conditions. Before using the products, carefully check the effects on their quality and performance, and determine whether or not they can be used.
 1. In liquid, such as water, oil, chemicals, or organic solvent
 2. In direct sunlight, outdoors, or in dust
 3. In salty air or air with a high concentration of corrosive gas, such as Cl₂, H₂S, NH₃, SO₂, or NO₂
 4. In an environment where strong static electricity or electromagnetic waves exist
 5. In an environment where these products cause dew condensation
 6. Sealing or coating of these products or a printed circuit board on which these products are mounted, with resin or other materials
- These products generate Joule heat when energized. Carefully position these products so that their heat will not affect the other components.
- Carefully position these products so that their temperatures will not exceed the category temperature range due to the effects of neighboring heat-generating components. Do not mount or place heat-generating components or inflammables, such as vinyl-coated wires, near these products .
- Note that non-cleaning solder, halogen-based highly active flux, or water-soluble flux may deteriorate the performance or reliability of the products.
- Carefully select a flux cleaning agent for use after soldering. An unsuitable agent may deteriorate the performance or reliability. In particular, when using water or a water-soluble cleaning agent, be careful not to leave water residues. Otherwise, the insulation performance may be deteriorated.

(2) Precautions for storage

The performance of these products, including the solderability, is guaranteed for a year from the date of arrival at your company, provided that they remain packed as they were when delivered and stored at a temperature of 5 °C to 35 °C and a relative humidity of 45 % to 85 %.

Even within the above guarantee periods, do not store these products in the following conditions. Otherwise, their electrical performance and/or solderability may be deteriorated, and the packaging materials (e.g. taping materials) may be deformed or deteriorated, resulting in mounting failures.

1. In salty air or in air with a high concentration of corrosive gas, such as Cl₂, H₂S, NH₃, SO₂, or NO₂
2. In direct sunlight

<Package markings>

Package markings include the product number, quantity, and country of origin. In principle, the country of origin should be indicated in English.