

XC6413 Series

High Speed LDO Regulators

Low ESR Cap. Compatible, Voltage Detector Function

July 15, 2003 Ver. 1

- ◆ Low Power Consumption : 35 μ A (TYP.)
- ◆ Dropout Voltage : 60mV @ 30mA
: 200mV @ 100mA
- ◆ Maximum Output Current : more than 300mA (380mA limit)
(1.8V \leq VR_{OUT} \leq 5.3V)
- ◆ Highly Accurate : \pm 2%
- ◆ VR Setting Output Voltage Range : 0.9V ~ 5.5V
- ◆ Detect Voltage Setting Range : 0.9V ~ 6.0V (VIN : \geq 2.0V)
- ◆ Low ESR capacitor compatible

■ APPLICATIONS

- Mobile phones, Cordless phones
- Wireless communication equipment
- Cameras, Video recorders
- Portable games
- Portable AV equipment
- Reference voltage
- Battery powered equipment

■ GENERAL DESCRIPTION

The XC6413 series are highly precise, low noise, positive voltage LDO regulators with voltage detector manufactured using CMOS processes. More the series achieves high ripple rejection and low dropout and consists of a voltage reference, an error amplifier, a current limiter and a phase compensation circuit plus a driver transistor. Detect voltage is selectable in 0.1V increments within a range of 0.9V ~ 6.0V and VR output voltage is selectable within a range of 0.9V~5.5V.

The series is also compatible with low ESR ceramic capacitors which give added output stability. This stability can be maintained even during load fluctuations due to the excellent transient response of the series. The current limiter's foldback circuit also operates as a short protect for the output current limiter and the output pin.

The series provides options to choose suited functions to each systems such as detector monitoring, detector output logic, CE and EN pin input logic, internal pull-up / down resistance, power ready (PR) function.

The IC's internal regulator circuitry can be in stand-by mode by the EN function with the XC6413 A to C series.

The whole IC's circuitry can be in stand-by mode via CE function with the XC6413D series (semi-custom). In the stand by mode, power consumption can be greatly reduced.

XC6413 A and B series has toggle operation function. The regulator output can be OFF when XC6413B series detect voltage (semi-custom). XC6413E series can monitor the other power source by using VSEN pin (semi-custom).

By the function to delay capacitor, XC6413F series can delay VD output. Delay time can be regulated by a capacitor (semi-custom).

Options setup of detector monitoring, detector output logic, CE/EN pin input logic, internal pull-up and pull-down resistance etc. are possible.

The function such as Power Ready (PR) function which suited systems, can be chosen (semi-custom).

■ FEATURES

- | | |
|----------------------------------|---|
| Maximum Output Current | : more than 300mA
(380mA limit)
(1.8V \leq VR _{OUT} \leq 5.3V) |
| Dropout Voltage | : 200mV (I _{ROUT} =100mA) |
| Maximum Operating Voltage | : 2.0V ~ 10.0V |
| VR Setting Output Voltage Range | : 0.9V ~ 5.5V (0.1V step) |
| VD Detect Voltage Setting Range | : 0.9V ~ 6.0V (0.1V step) |
| When monitoring VIN | : more than 2.0V |
| VR setting voltage accuracy | : \pm 2% |
| VD detect voltage accuracy | : \pm 2% |
| VR.VD Temperature Coefficient | : \pm 100ppm/ $^{\circ}$ C (TYP.) |
| Low Power Consumption | : TYP. 35 μ A |
| High Ripple Rejection | : 65dB (10kHz) |
| Low Output Noise | : 30mV _{rms} |
| Low ESR Capacitor Compatible | : Ceramic capacitor |
| Ultra Small Packages | : SOT-25 (SOT-23-5)
: USP-6B
: SOT-89-5 |
| Operational Ambient Temperature: | : - 40 ~ 85 $^{\circ}$ C |

■ TYPICAL APPLICATIONS

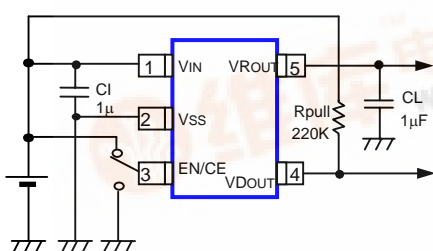

XC6413A ~ D Series

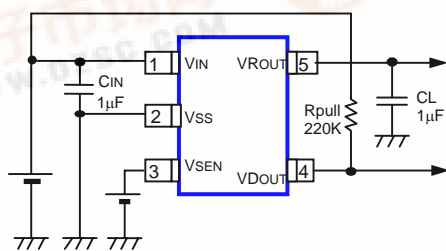

XC6413E Series

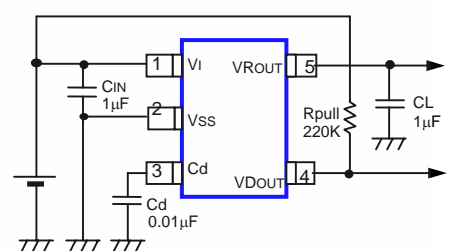

XC6413F Series



XC6413 Series

High Speed LDO Regulators

Low ESR Cap. Compatible, Voltage Detector Function

PIN CONFIGURATION

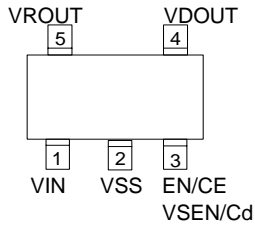

**SOT-25
(TOP VIEW)**

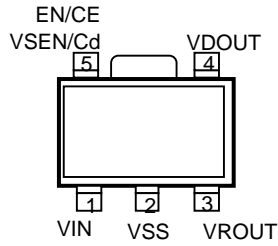

**SOT-89-5
(TOP VIEW)**

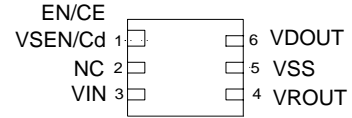

**USP-6B
(TOP VIEW)**

PIN ASSIGNMENT

PIN NUMBER			PIN NAME	FUNCTION
SOT-25	SOT-89-5	USP-6B		
1	1	3	VIN	Power Input
2	2	5	VSS	Ground
3	5	1	EN	VR On / Off Control
3	5	1	CE	On / Off Control
3	5	1	VSEN	VD Monitoring
3	5	1	Cd	Delay capacitor Connection
4	4	6	VDOUT	VD Output
3	3	4	VROUT	VR Output
-	-	2	NC	No connection

SELECTION GUIDE

1. Toggle Function, VD self-saturation as option

SERIES	TOGGLE FUNCTION (BUILT-IN)
XC6413A	VD with Toggle Function
XC6413B	VD with Toggle Function and Self-Saturation
XC6413C ~ F	VD without Toggle Function

2. Stand-by mode function as option

SERIES	STAND-BY MODE FUNCTION
XC6413A ~ C	VR with Stand-by mode function
XC6413D	Chip Stand-by mode function
XC6413E, F	No Stand-by mode function

3. CE / EN Input Logic, Internal Pull-up / down as option

SERIES	CE INPUT LOGIC
XC6413 * A ~ D	High Active with pull down
XC6413 * E ~ K	High Active with no pull down
XC6413 * L ~ P	Low Active with pull up
XC6413 * R ~ U	Low Active with no pull up

* : A ~ D series

4. VD Sense as option

SERIES	VD SENSE PIN
XC6413 * A, B, E, F, L, M, R, S, V, X	VIN
XC6413 * C, D, H, K, N, P, T, U, Y, Z	VOUT
XC6413 E V ~ Z	VSEN

* : A ~ D and F series

5. VD Output Logic as option

SERIES	VD OUTPUT LOGIC FUNCTION
XC6413A ~ F	Detect L or Detect H

6. VD Delay Function as option

SERIES	DELAY FUNCTION
XC6403A ~ E	No Delay
XC6403F	Delay time adjustable by connecting Cd

XC6413 Series

High Speed LDO Regulators

Low ESR Cap. Compatible, Voltage Detector Function

ORDERING INFORMATION

XC6413 ①②③④⑤⑥

PIN NUMBER	FUNCTION	PIN NUMBER	FUNCTION
①	Denotes Optional Functions : A : Toggle and EN Function (preliminary) B : Toggle, EN Function, VD signal/VR OFF function (preliminary) C : EN Function (preliminary) D : CE Function (preliminary) E : VSEN Pin (preliminary) F : Cd Pin	⑤	Denotes Packaging Types: D : USP-6B M : SOT-23 P : SOT-89-5
②	Denotes Types : As in the chart below.	⑥	Denotes Taping Direction: R : Standard feed L : Reverse feed
③④	Sequence Number according to R&D standard in regards to output voltage and detect voltage VR Setting Output Voltage Range : 0.9V ~ 5.5V Detect Voltage Setting Range : 0.9V ~ 6.0V 0.1V step increments is available		

PIN NUMBER : ② Types

②	EN / CE FUNCTION	EN / CE LOGIC	PULL UP/DOWN RESISTANCE	VD SENSE PIN	VD OUTPUT LOGIC	PIN NUMBER ①
A	Function	High Active	Function	VIN	Detect L	A ~ D Series
B	Function	High Active	Function	VIN	Detect H	
C	Function	High Active	Function	VR0UT	Detect L	
D	Function	High Active	Function	VR0UT	Detect H	
E	Function	High Active	Nonfunctional	VIN	Detect L	
F	Function	High Active	Nonfunctional	VIN	Detect H	
H	Function	High Active	Nonfunctional	VR0UT	Detect L	
K	Function	High Active	Nonfunctional	VR0UT	Detect H	
L	Function	Low Active	Function	VIN	Detect L	
M	Function	Low Active	Function	VIN	Detect H	
N	Function	Low Active	Function	VR0UT	Detect L	
P	Function	Low Active	Function	VR0UT	Detect H	
R	Function	Low Active	Nonfunctional	VIN	Detect L	
S	Function	Low Active	Nonfunctional	VIN	Detect H	
T	Function	Low Active	Nonfunctional	VR0UT	Detect L	
U	Function	Low Active	Nonfunctional	VR0UT	Detect H	
V	Nonfunctional	-	-	VIN / VSEN	Detect L	E & F Series
X	Nonfunctional	-	-	VIN / VSEN	Detect H	
Y	Nonfunctional	-	-	VR0UT	Detect L	F Series
Z	Nonfunctional	-	-	VR0UT	Detect H	

* XC6413A, B, C, D, E Series are under development. For further detail, please ask your sales contacts.

XC6413 Series

High Speed LDO Regulators

Low ESR Cap. Compatible, Voltage Detector Function

ORDERING INFORMATION (CONTINUED)

PIN NUMBER ③, ④ Type (80 ~ 99 : Standard voltage products)

③④	VROUT	VDOUT	③④	VROUT	VDOUT	③④	VROUT	VDOUT	③④	VROUT	VDOUT
01			11			80	1.8	1.6	90		
02			12			81	2.8	3.1	91		
03			13			82	1.8	2.0	92		
04			14			83	2.5	2.8	93		
05			15			84	2.85	3.2	94		
06			16			85	3.0	3.3	95		
07			17			86	3.5	3.8	96		
08			18			87	3.0	4.2	97		
09			19			88	3.3	4.0	98		
10			20			89			99		

Except for the standard products, minimum ordering quantity is 15K.

ABSOLUTE MAXIMUM RATINGS

PARAMETER		SYMBOL	RATINGS	UNITS
VIN Pin Voltage		VIN	12	V
VROUT Current		VRIOUT	700	mA
VROUT Pin Voltage		VROUT	VSS -0.3 ~ VIN +0.3	V
VDOUT Current		VDIOUT	50	mA
VD Pin Voltage		VDOUT	VSS -0.3 ~ 12.0	V
VCE / VSEN / Cd Pin Voltage		VCE / VSEN / Cd	VSS -0.3 ~ VIN + 0.3	V
Continuous Total Power Dissipation	SOT-25	Pd	250	mW
	SOT-89-5		500	
	USP-6B		100	
Operating Ambient Temperature		Topr	- 40 ~ + 85	°C
Storage Temperature		Tstg	- 55 ~ + 125	°C

PACKAGING INFORMATION

○ SOT-25 (SOT-23-5)

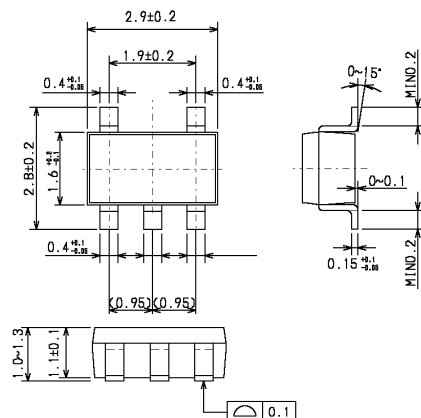

○ SOT-89-5

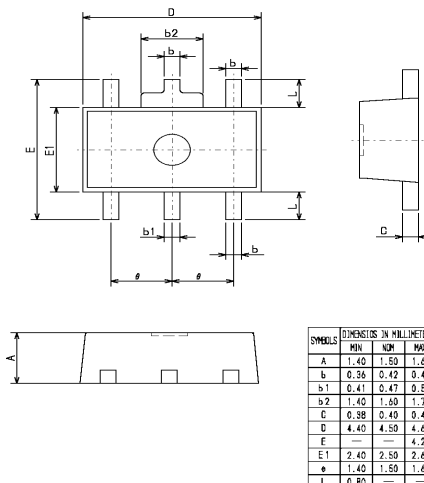

○ USP-6B

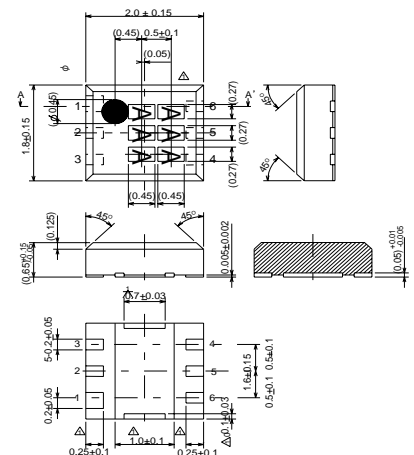

ELECTRICAL CHARACTERISTICS

XC6413 FV / FX / FY / FZ Series

Ta=25°C

	PARAMETER	SYMBOL	CONDITIONS	MIN	TYP	MAX	UNITS	CIRCUIT	
VOLTAGE REGULATOR	VR Output Voltage	VROUT(E)	IROUT=30mA	x 0.98	VROUT(T)	x 1.02	V	1	
	VR Maximum Output Current (0.9 ~ 1.7V product)	IROUTMAX	VIN = 3.1V	150			mA	1	
	VR Maximum Output Current (1.8 ~ 5.3V product)	IROUTMAX	VIN=3.1V @ VROUT ≤ 2.1V	300			mA	1	
	VR Load Regulation	ΔVROUT	1mA ≤ IROUT ≤ 100mA		15	50	mV	1	
	VR Dropout Voltage	Vdif1	IROUT=30mA		E-1		mV	1	
			IROUT=100mA		E-2		mV	1	
	Supply Current (FV / FX / FY / FZ Series)	IDD	VIN=VROUT(T)+1.0V		35	70	μA	2	
	VR Line Regulation	$\frac{\Delta VROUT}{\Delta VIN \cdot VROUT}$	VROUT(T)+1.0V ≤ VIN ≤ 10.0V IROUT=30mA		0.01	0.20	% / V	1	
	Input Voltage	VIN		2.0		10.0	V	-	
	VR Output Voltage Temperature Characteristics	$\frac{\Delta VROUT}{\Delta T_{opr} \cdot VROUT}$	IROUT=30mA -40°C ≤ Topr ≤ 85°C		±100		ppm / °C	1	
	VR Ripple Rejection Rate	PSRR	VIN=[VROUT(T)+1.0]V+0.5Vp-pAC When VROUT(T) ≤ 1.25V ⇒ VIN=2.25V+0.5Vp-pAC IROUT=50mA, f=10kHz		65		dB	3	
	VR Current Limiter (1.8V or more)	IRlim	VIN=3.1V @ VROUT ≤ 2.1V	300	380		mA	1	
VR Current Limiter (1.7V or less)	IRlim	VIN=3.1V		380		mA	1		
Short-circuit Current	IRshort	VIN=VROUT(T)+1.0V VIN=3.1V @ VROUT ≤ 2.1V		50		mA	1		
VOLTAGE DETECTOR	VD Detect Voltage	VDF (E)		x 0.98	VDF (T)	x 1.02	V	4	
	VD Hysteresis Range	VHYS		VDF (T) x 0.02	VDF (T) x 0.05	VDF (T) x 0.08	V	4	
	VD Output Current	IDOUT	VROUT = 0.5V						
			VIN = 2.0V	2.0	5.0				
			VIN = 3.0V	4.0	7.5				
			VIN = 4.0V	5.0	9.5				
			VIN = 5.0V	6.0	10.5				
VIN = 6.0V			6.5	11.5					
VIN = 7.0V	7.0	12.5							
VIN = 8.0V	7.5	13.5							
VIN = 9.0V	8.0	14.5							
VIN = 10.0V	8.5	14.5							
VD Detect Voltage Temperature Characteristics	$\frac{\Delta VDF}{\Delta T_{opr} \cdot VDF}$	-40°C ≤ Topr ≤ 85°C		±100		ppm / °C	4		
Delay Resistance	Delay	VIN=7.0V, Cd=0V Delay Resistance=7.0V/Delay Current	1.0	2.0	3.5	MΩ	6		

NOTE:

(NOTE 1) Unless otherwise stated, VIN=VOUT(T)+1.0V

(NOTE 2) VROUT(T)=Specified VR Output Voltage

(NOTE 3) VOUT(E)=Actual VR Output Voltage

(I.e. the VR output voltage when "VROUT(T)+1.0V" is provided at the VIN pin while maintaining a certain IROUT value).

(NOTE 4) $V_{dif} = (VIN1^{(NOTE6)} - VROUT1^{(NOTE5)})$

(NOTE 5) A voltage equal to 98% of the VR Output Voltage whenever an amply stabilized VROUT1=IROUT{VROUT(T)+1.0V} is input.

(NOTE 6) VIN1=The Input Voltage when VOUT1 appears as Input Voltage is gradually decreased.

(NOTE 7) VDF (T) : Specified Detect Voltage value

(NOTE 8) VDF (E) : Actual Detect Voltage value. Refer E-0 chart for VDF(T) less than 1.5V.

(NOTE 9) VD output current = sink current value when detecting.

XC6413 Series

High Speed LDO Regulators

Low ESR Cap. Compatible, Voltage Detector Function

VR DROPOUT VOLTAGE

SYMBOL PARAMETER SPECIFIED DETECT VOLTAGE OUTPUT VOLTAGE	E-0		E-1		E-1	
	OUTPUT VOLTAGE DETECT VOLTAGE		DROPOUT VOLTAGE 1 (mV) (IOUT=30mA)		DROPOUT VOLTAGE 2 (mV) (IOUT=100mA)	
	(V)		Ta=25°C		Ta=25°C	
	VR0UT(T) VDF(T)	VR0UT / VDF		Vdif1	Vdif1	Vdif2
	MIN.	MAX.	TYP.	MAX.	TYP.	MAX.
0.90	0.870	0.930	1050	110	1150	1200
1.00	0.970	1.030	1000	110	1050	1200
1.10	1.070	1.130	900	100	950	1100
1.20	1.170	1.230	800	900	850	1000
1.30	1.270	1.330	700	800	750	900
1.40	1.370	1.430	600	700	650	800
1.50	1.470	1.530	500	600	550	700
1.60	1.568	1.632	400	500	500	600
1.70	1.666	1.732	300	400	400	500
1.80	1.764	1.836	200	300	300	400
1.90	1.862	1.938	120	150	280	380
2.00	1.960	2.040	80	120	240	350
2.10	2.058	2.142	80	120	240	330
2.20	2.156	2.244	80	120	240	330
2.30	2.254	2.346	80	120	240	310
2.40	2.352	2.448	80	120	240	310
2.50	2.450	2.550	70	100	220	290
2.60	2.548	2.652	70	100	220	290
2.70	2.646	2.754	70	100	220	290
2.80	2.744	2.856	70	100	220	270
2.90	2.842	2.958	70	100	220	270
3.00	2.940	3.060	60	90	200	270
3.10	3.038	3.162	60	90	200	250
3.20	3.136	3.264	60	90	200	250
3.30	3.234	3.366	60	90	200	250
3.40	3.332	3.468	60	90	200	250
3.50	3.430	3.570	60	90	200	250
3.60	3.528	3.672	60	90	200	250
3.70	3.626	3.774	60	90	200	250
3.80	3.724	3.876	60	90	200	250
3.90	3.822	3.978	60	90	200	250
4.00	3.920	4.080	60	80	180	230
4.10	4.018	4.182	60	80	180	230
4.20	4.116	4.284	60	80	180	230
4.30	4.214	4.386	60	80	180	230
4.40	4.312	4.488	60	80	180	230
4.50	4.410	4.590	60	80	180	230
4.60	4.508	4.692	60	80	180	230
4.70	4.606	4.794	60	80	180	230
4.80	4.704	4.896	60	80	180	230
4.90	4.802	4.998	60	80	180	230
5.00	4.900	5.100	50	70	160	210
5.10	4.998	5.202	50	70	160	210
5.20	5.096	5.304	50	70	160	210
5.30	5.194	5.406	50	70	160	210
5.40	5.292	5.508	50	70	160	210
5.50	5.390	5.610	50	70	160	210
5.60	5.488	5.712				
5.70	5.586	5.814				
5.80	5.684	5.916				
5.90	5.782	6.018				
6.00	5.880	6.120				

TEST CIRCUITS

○ Circuit 1 XC6413F Series

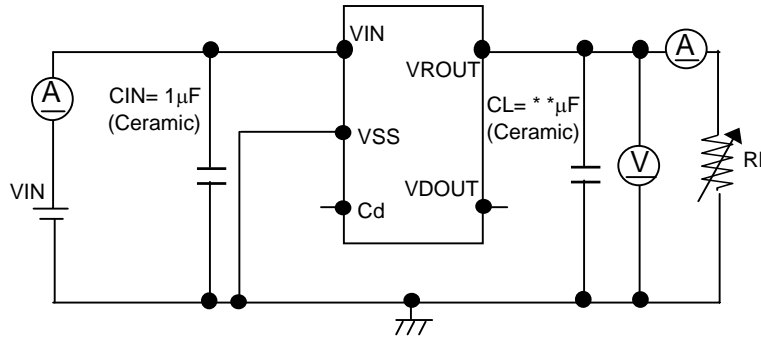

○ Circuit 2 XC6413F Series

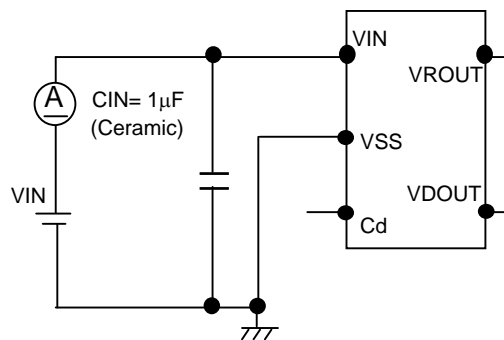

○ Circuit 3 XC6413F Series

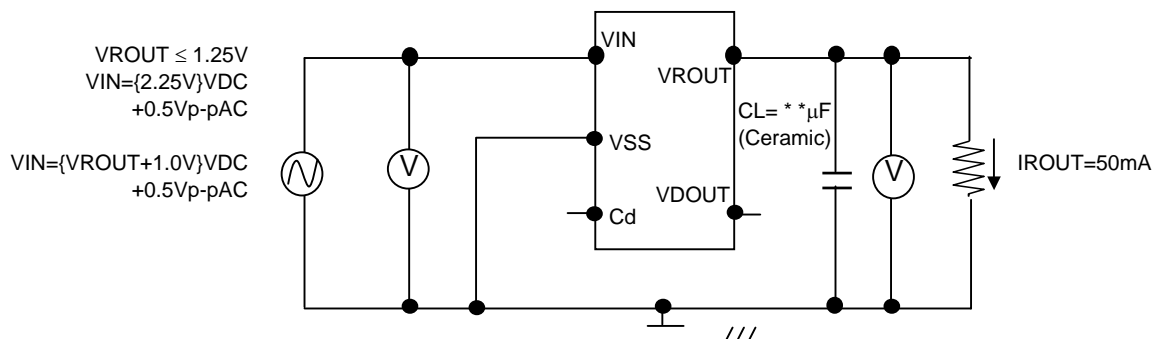

Output Capacitor Corresponding Chart

VROUT	0.9 ~ 1.2V	1.3 ~ 1.7V
CL	more than 4.7µF	more than 2.2µF

■ TEST CIRCUITS (CONTINUED)

○ Circuit 4 XC6413F Series [VD Sense, VIN type]

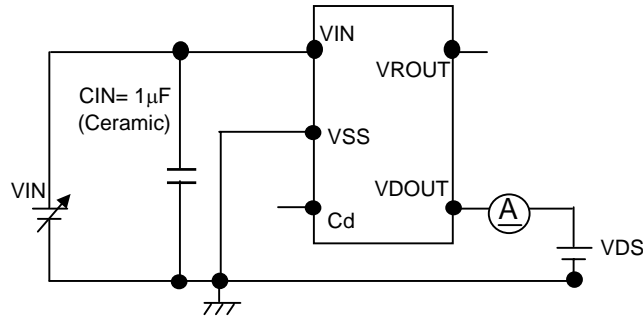

XC6413F Series [VD Sense, VROUT type]

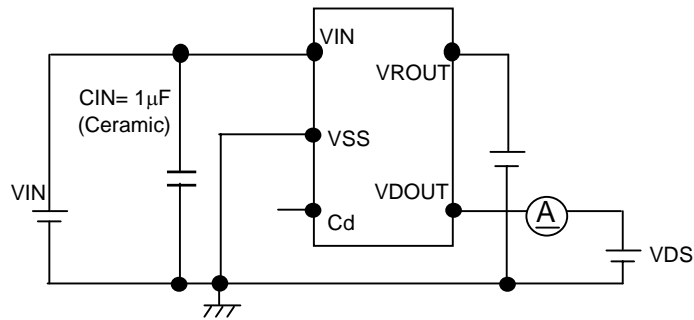

○ Circuit 5 XC6413F Series [VD Sense, VIN type]

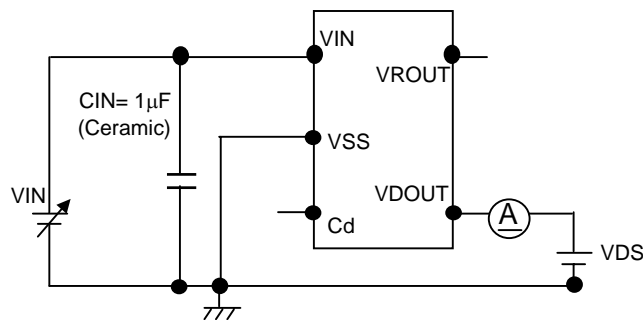

XC6413F Series [VD Sense, VROUT type]

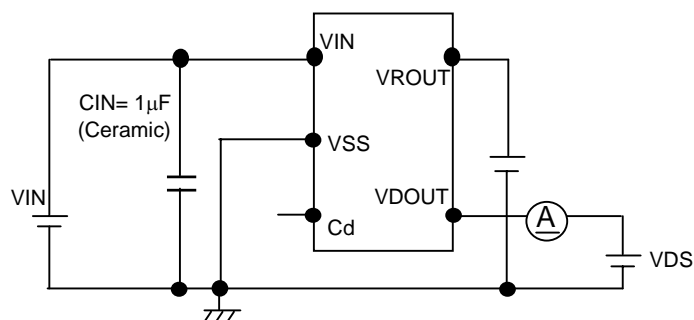

■ TEST CIRCUITS (CONTINUED)

○ **Circuit 6** XC6403F Series [VD Sense, VIN type]

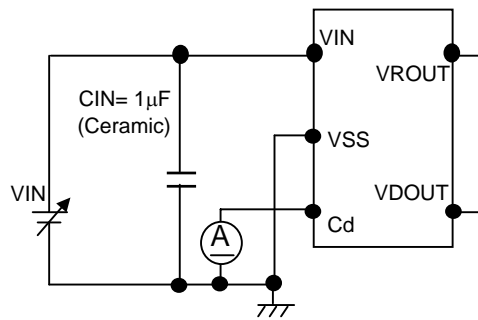

XC6403F Series [VD Sense, VROUT type]

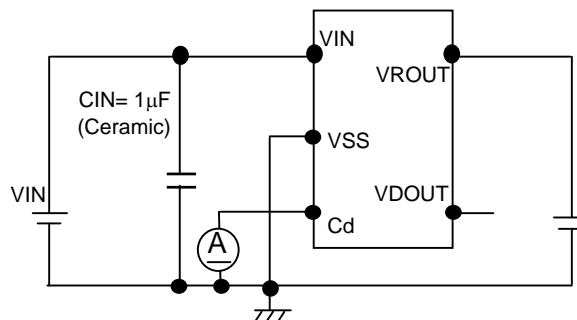

■ BLOCK DIAGRAM

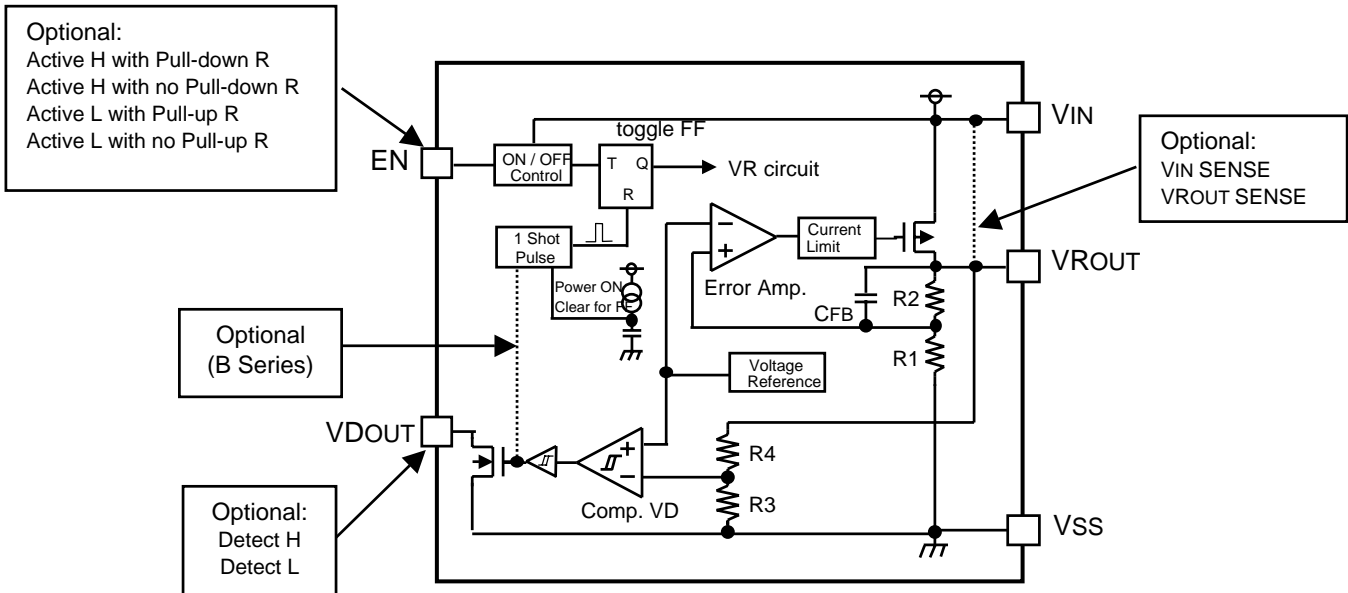

XC6413A, B Series

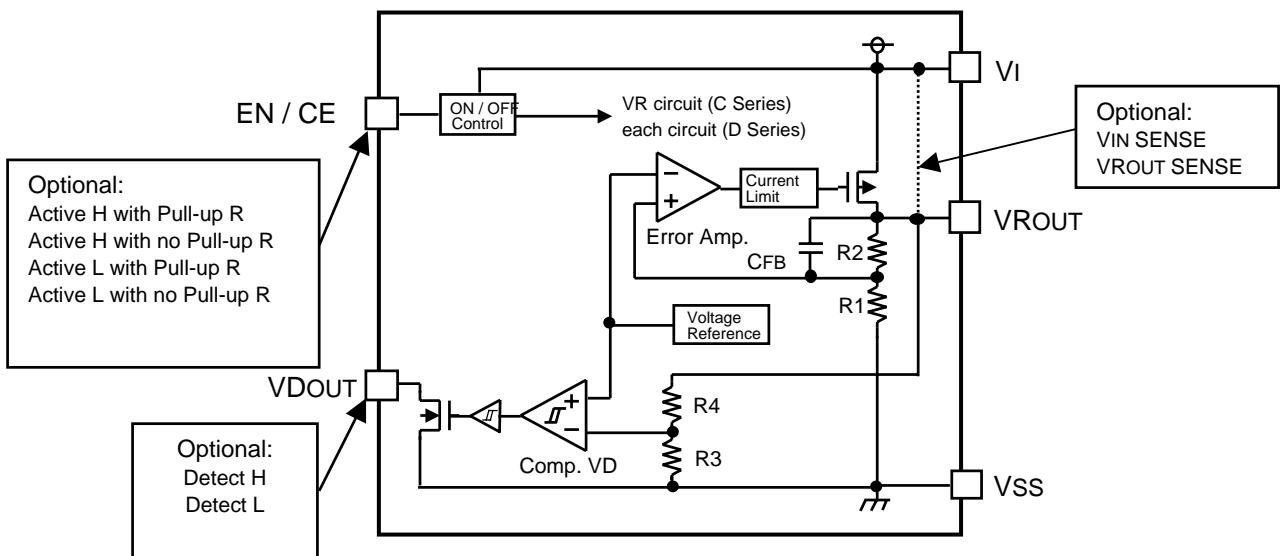

XC6413C, D Series

■ BLOCK DIAGRAM (CONTINUED)

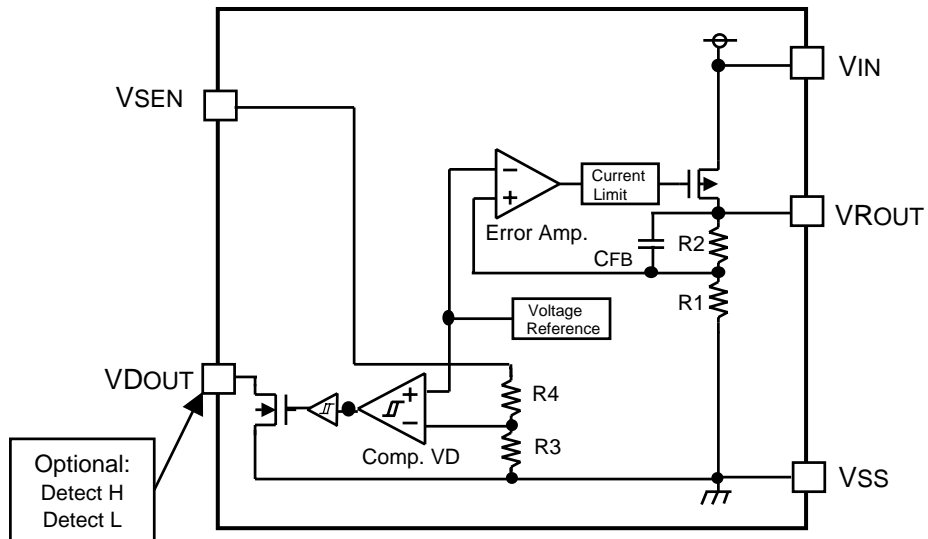

XC6413E Series

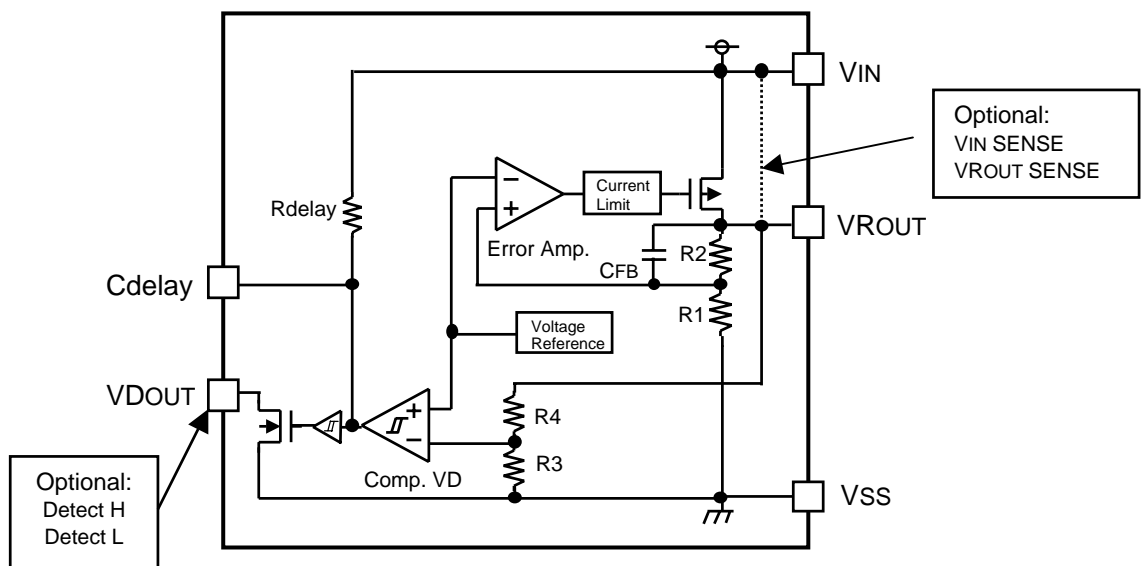

XC6413F Series

<Output voltage regulator control>

The voltage divided by resistors R1 & R2 which are connected to VROUT pin is compared with the internal reference voltage by the error amplifier. The P-Channel MOSFET, which is connected to the VOUT pin, is then driven by the subsequent output signal. The output voltage at the VROUT pin is controlled & stabilized by a system of negative feedback.

The current limit circuit and short protect circuit operate in relation to the level of output current. Further, the voltage regulator's internal circuitry can be shutdown via the CE pin's signal.

<Detector function with the XC6413 series>

The voltage divided by resistors R3 & R4 which are connected to VROUT pin, VIN or VSEN pin are compared with the internal reference voltage by the comparator. Option is available for the VDSSEN. A 'High' or 'Low' signal level can be output from the VDOOUT pin when the VD pin voltage level of less than the detect voltage is reached. Option is available for the VD output logic. As VDOOUT is an open-drain N-channel output, a pull-up resistor of about 220KΩ is needed to achieve a voltage output. Because of hysteresis at the detector function, output at the VDOOUT pin will invert when the detect voltage level increase more than the release voltage (105% of the detect voltage). Even when the XC6413A, B, C, series are in stand-by mode, the voltage detector function operates and the output voltage at VDOOUT will output according to the voltage level at VDSSEN voltage.

In stand-by, if a voltage of the recovery voltage is present at the VROUT pin (from another power source), the VDOOUT pin will be high impedance and pull up voltage will be output at VDOOUT. By connecting Cdelay pin to a capacitor (Cd), XC6413F series can put delay time to VDOOUT voltage when releasing voltage. Delay time can be set by the internal resistance (2MΩ fixed) and the value of Cd as the following equation.

$$\text{Delay Time} = C_{\text{delay}} \times R_{\text{delay}} \times 0.7$$

<Low ESR Capacitors>

With the regulator of XC6413 series, a stable output voltage is achievable even if used with low ESR capacitors as a phase compensation circuit is built-in. In order to ensure the effectiveness of the phase compensation, we suggest that an output capacitor (CL) is connected as close as possible to the output pin (VROUT) and the VSS pin. Please use an output capacitor (CL) with a capacitance referring to the chart below, and an 1μF of input capacitor (CIN) be connected between VIN and VSS to stabilize input power source.

VROUT	0.9 ~ 1.2V	1.3 ~ 1.7V
CL	more than 4.7μF	more than 2.2μF

<Current Limiter, Short-Circuit Protection>

The regulator of XC6413 series offers a combination of current limit and circuit protection by means of a built-in fixed current limiter circuit & a foldback circuit. When the load current reaches the current limit level, the fixed current limiter circuit operates and output voltage drops. As a result of this drop in output voltage, the foldback circuit operates, output voltage drops further and output current decreases. When the output pin is shorted, a current of about 50mA flows.

<EN / CE Pin>

The IC's internal regulator circuitry can be shutdown via the signal from the EN pin with the XC6413A, B, C series. In shutdown mode, output at the VROUT pin will be pulled down to the VSS level via R1 & R2. The whole IC's circuitry can be shut down via CE pin with the XC6413D series and power consumption can be reduced to around 0 μA. In shutdown mode, output of VD is voltage after detecting. When choosing Detect L, input current can be set by the following formula.

$$\text{Input Current} = \text{VIN voltage} / \text{Pull Up Resistance}$$

In standby mode, the above input current can be withheld by connecting pull-up resistance between VROUT and VDOOUT.

Note that as the XC6413*E to K of XC6413A to D series are 'High Active/No Pull Down' and XC6413*R to U of XC6413A to D series are 'Low Active/No Pull UP', operations will become unstable with the CE pin open (See the chart below).

SERIES	EN/CE INPUT LOGIC
XC6413 * A ~ D	High Active with pull down
XC6413 * E ~ K	High Active with no pull down
XC6413 * L ~ P	Low Active with pull up
XC6413 * R ~ U	Low Active with no pull up

We suggest that you use this IC with either a VIN voltage or a VSS voltage input at the EN or CE pin. If this IC is used with the correct specifications for the EN or CE pin, the IC will operate normally. However, supply current may increase as a result of through current in the IC's internal circuitry if a voltage other than VIN or VSS is applied.

<Toggle Operation>

XC6413 series has built-in toggle ON/OFF switch which repeats an on/off operation via the EN pin's leading edge signal when the EN logic is "High" active, and via the EN pin's falling edge signal when the EN logic is "Low" active (Please also refer the figure below). Please input EN input signal more than 500nsec. If the EN input signal is less than 500nsec, there is the case that the circuit falls to respond and the toggle function cease to work. To operate the toggle function properly, please eliminate the noise from EN signal by using RC filter, etc. A flip-flop FF used for toggle operation can be reset within the XC6413B series directly by the signal from the voltage detector. The signal of the voltage detector will be transformed to one-shot signal to reset FF. The voltage regulator output when the EN pin release the signal again.

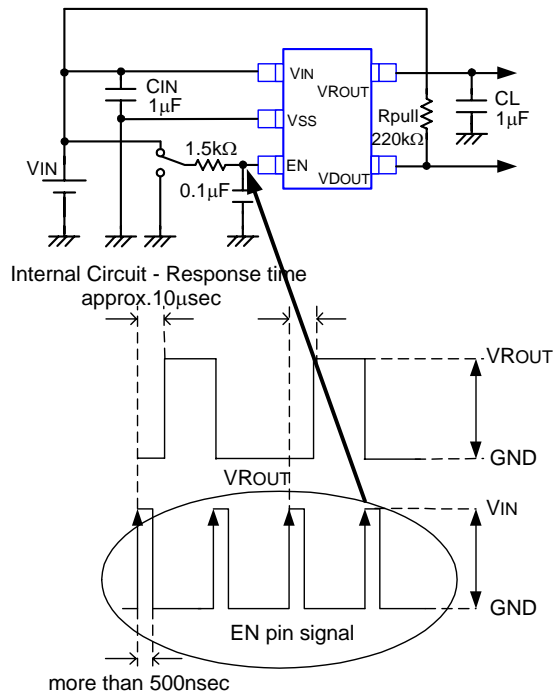

EN Logic "High" Active

■ NOTES ON USE

1. Please use this IC within the stated absolute maximum ratings. The IC is liable to malfunction should the ratings be exceeded.
2. Where wiring impedance is high, operations may become unstable due to noise and/or phase lag depending on output current.
Please strengthen VIN and VSS wiring in particular.
3. Please wire the input capacitor (CIN) and the output capacitor (CL) as close to the IC as possible.
In case that rapid input fluctuation or load fluctuation are occurred, please enlarge capacitor value such as CIN or CL to stabilize the operation.