

XC9106 / 07 Series

Preliminary

捷多邦 专业PCB打样工厂, 24小时加急出货
 PWM Control, PWM/PFM Switching Control,
 Step-up DC/DC Converters

Externally Applied Reference Voltage (Vref)

June 26, 2003 Ver. 2

- ◆ Externally Applied Reference Voltage (Vref)
- ◆ Ceramic Capacitors Compatible
- ◆ Input Voltage Range: 0.9V~10.0V
- ◆ Oscillation Frequency: 300kHz, 100kHz (±15%)
- ◆ PWM Control (XC9106)
 PWM/PFM Automatic Switching Control (XC9107)
- ◆ SOT-25 / USP-6B Packages

GENERAL DESCRIPTION

The XC9106 / 07 series are step-up DC/DC controller ICs with an externally applied reference voltage (Vref). Output voltage will be set with external resistors (RFB1 and 2) and Vref value. The series make it easy to control output voltage externally and are suited to software applications that need to vary voltage, such as LCD power supply for PDA. Output will be stable no matter which load capacitors are used but if a low ESR capacitor is used, RSENSE of about 0.1Ω will be required and phase compensation will be achieved. This makes the use of ceramic capacitors much easier, and allows for lower output ripple and reduced PCB area requirements. Tantalum and electrolytic capacitors can also be used, in which case, RSENSE becomes unnecessary. Oscillation frequencies of high clock, low ripple 300kHz and low supply current 100kHz are available. The XC9107 series are PWM/PFM automatic switching controlled. Control switches from PWM to PFM during light loads with the XC9107 and the series is highly efficient from light loads to large output currents. By bringing the whole circuit down while the series is in the stand-by mode (CE/PWM pin : low), supply current can be reduced to less than 1.0μA.

APPLICATIONS

- Power Supply for LCD
- PDAs
- Cellular Phones
- Palmtop Computers
- Portable Audio Systems
- Various Multi-function Power Supplies

FEATURES

Input Voltage Range:	0.9V ~ 10.0V
Power Supply Voltage Range:	1.8V ~ 10.0V and more than Vref+0.7V
VREF Input Range:	0.8V ~ 2.5V (±2.0%)
Output Voltage:	Vref x external split resistor ratio $V_{OUT} = V_{ref} \times (R_{FB1} + R_{FB2}) / R_{FB2}$
Oscillation Frequency:	300kHz, 100kHz ±15%
Output Current:	more than 30mA (VIN=3.3V, VOUT=20V, when peripheral components are used as in the circuits below.)
Controls:	PWM (XC9106) PWM/PFM auto-switching (XC9107)
High Efficiency:	85% (TYP.)
Stand-by Current:	ISTB=1.0μA (MAX.)
Load Capacitors:	Low ESR capacitors compatible
Packages:	SOT-25, USP-6B

TYPICAL APPLICATION CIRCUIT

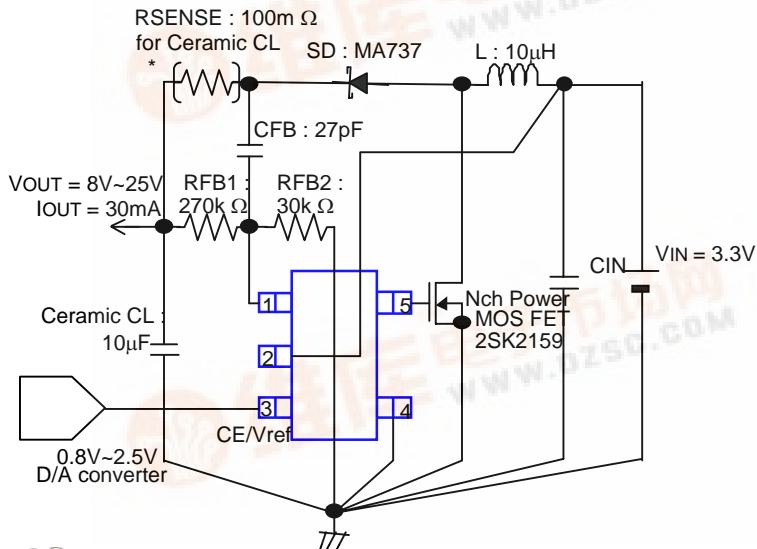

TYPICAL APPLICATION PERFORMANCE

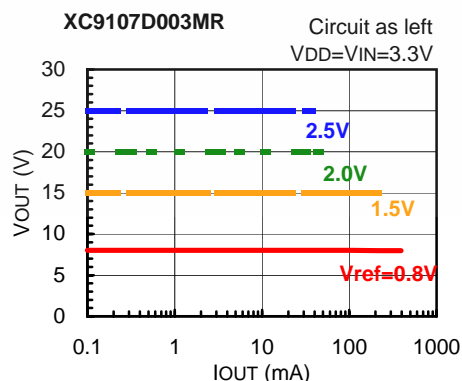
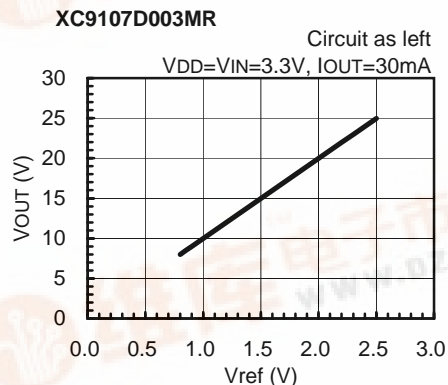

* RSENSE is of no use in light load (uncontinuous mode) applications such as a small LCD, even using ceramic capacitor.

XC9106 / 07 Series

PWM Control, PWM/PFM Switching Control, Step-up DC/DC Converters

Preliminary

Externally Applied Reference Voltage (Vref)

■ PIN CONFIGURATION

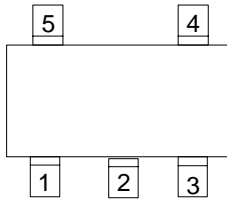

SOT-25
(TOP VIEW)

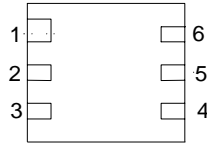

USP-6B
(TOP VIEW)

■ PIN ASSIGNMENT

PIN NUMBER		PIN NAME	FUNCTION
SOT-25	USP-6B		
1	6	FB	Output Resistor Connection
2	2	VDD	Supply Voltage
3	4	CE/ Vref	Serves as both Chip Enable pin and Reference Voltage Apply pin.
4	3	GND	Ground
5	1	EXT	External Transistor Connection
-	5	NC	No Connection

■ ORDERING INFORMATION

XC9106D①②③④⑤

XC9106 Series: PWM Control

①②		Reference Voltage (apply external) Fixed : 00
③	3	Oscillation Frequency: 300kHz
	1	100kHz
④	M	Package: SOT-25 (1 reel = 3000 pcs.)
	D	USP-6B (1 reel = 3000 pcs.)
⑤	R	Embossed Tape: Standard Feed
	L	Reverse Feed

XC9107D①②③④⑤

XC9107 Series: PWM/PFM automatic switching control
(Ordering information is the same as XC9106 Series)

■ PACKAGING INFORMATION

○ SOT-25 (SOT-23-5)

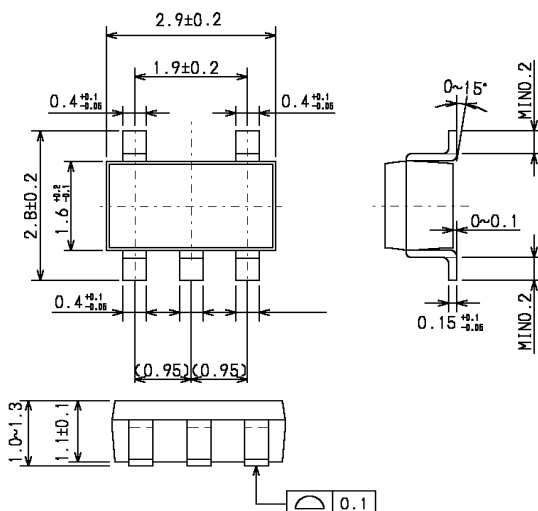

○ USP-6B

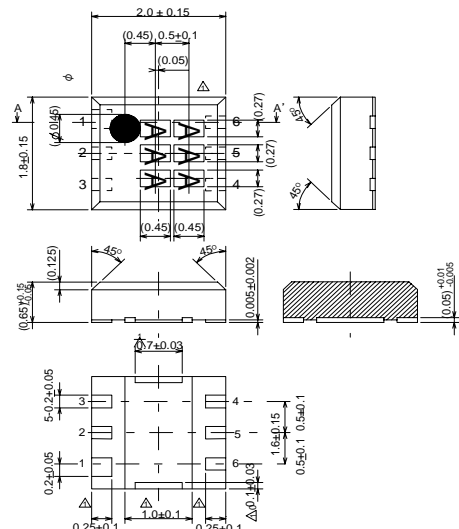

■ BLOCK DIAGRAM

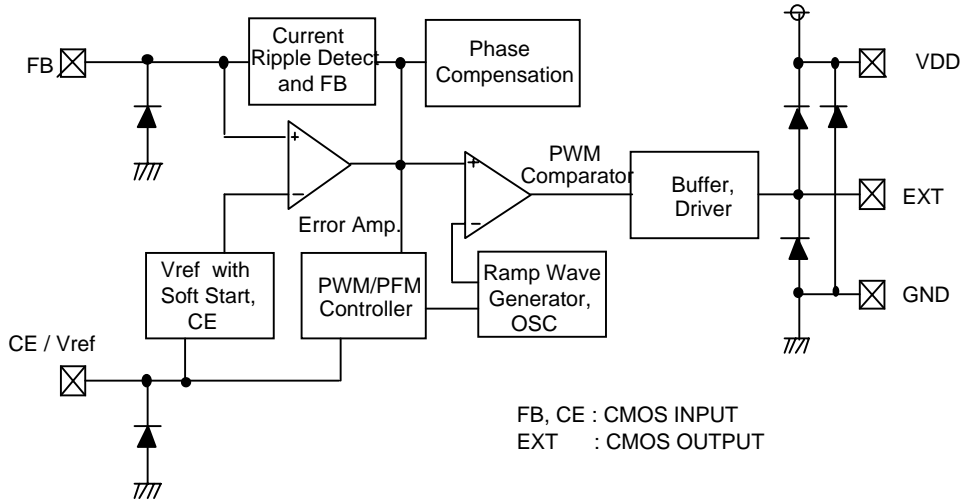

■ ABSOLUTE MAXIMUM RATINGS

Ta = 25°C

PARAMETER	SYMBOL	RATINGS	UNITS
VDD pin Voltage	VDD	-0.3 ~ 12.0	V
FB pin Voltage	VFB	-0.3 ~ 12.0	V
CE / Vref pin Voltage	VCE / Vref	-0.3 ~ 12.0	V
EXT pin Voltage	VEXT	-0.3 ~ VDD + 0.3	V
EXT pin Current	IEXT/	±100	mA
Power Dissipation	Pd	SOT-25	150
		USP-6B	100
Operating Ambient Temperature	Topr	-40 ~ +85	°C
Storage Temperature	Tstg	-55 ~ +125	°C

XC9106 / 07 Series

PWM Control, PWM/PFM Switching Control, Step-up DC/DC Converters

Preliminary

Externally Applied Reference Voltage (Vref)

■ ELECTRICAL CHARACTERISTICS

XC9106D001MR, XC9107D001MR

(FOSC=100 (kHz))

Ta=25°C

PARAMETER	SYMBOL	CONDITIONS	MIN.	TYP.	MAX.	UNITS	CIRCUIT
Output Voltage	VOUT	Vref = 0.9V	8.820	9.000	9.180	V	①
Reference Voltage Range	Vref		0.8		2.5	V	-
FB Control Voltage	VFB	Vref = 0.9V	0.784	0.800	0.816	V	④
		Vref = 0.9V	0.882	0.900	0.918		
		Vref = 2.5V	2.450	2.500	2.550		
Power Supply Voltage Range	VDD	VDD as shown right or (Vref applied voltage+0.7V)	1.8		10.0	V	-
Operation Start Voltage	VST1	Recommended Circuit using 2SD1628, IOU=1.0mA			0.9	V	③
Oscillation Start Voltage	VST2	No external connections CE/Vref=0.9V, Voltage applied, FB=0V			0.8	V	④
Operation Holding Voltage	VHLD	Recommended Circuit using 2SD1628, IOU=1.0mA			0.7	V	③
Supply Current 1	IDD1	Same as VST2, VDD=3.300V		29	41	μA	④
Supply Current 2	IDD2	Same as IDD1, FB=1.2V		14	19	μA	④
Stand-by Current	ISTB	Same as IDD1, CE/Vref=0V			1.0	μA	⑤
Oscillation Frequency	FOSC	Same as IDD1	85	100	115	KHz	④
Maximum Duty Ratio	MAXDTY	Same as IDD1	75	81	87	%	④
PFM Duty Ratio	PFMDTY	No Load (XC9106 series)	20	28	36	%	①
Efficiency	EFF1	Recommended Circuit using XP161A1355		85		%	①
Soft-start Time	TSS	Vref=0.9V	5.0	10.0	20.0	mS	①
CE "High" Voltage	VCEH	Same as IDD1	0.65			V	⑤
CE "Low" Voltage	VCEL	Same as IDD1			0.20	V	⑤
EXT "High" ON Resistance	REXTH	Same as IDD1, VEXT=VOU-0.4V		24	36	Ω	④
EXT "Low" ON Resistance	REXTL	Same as IDD1, VEXT=0.4V		16	24	Ω	④
CE "High" Current	ICEH	Same as IDD2, CE=0.8V	-1.0		0.0	μA	⑤
		Same as IDD2, CE=2.5V	0.0		2.5		
CE "Low" Current	ICEL	Same as IDD2, CE=0V			-0.1	μA	⑤
FB "High" Current	IFBH	Same as IDD2, FB=VDD			0.1	μA	⑤
FB "Low" Current	IFBL	Same as IDD2, FB=1.0V			-0.1	μA	⑤

Test Conditions: Unless otherwise stated, CL: ceramic, recommended MOS FET should be connected.

$$VDD = 3.30 \text{ (V)} \Rightarrow Vref = 0.09 \text{ (V)}, RFB1, 2 \times 10$$

$$VIN = 3.30 \text{ (V)} \Rightarrow IOU = 50 \text{ (mA)}$$

Notes 1* :

Although the IC starts step-up operations from a VDD of 0.8V, the output voltage and oscillation frequency are stabilized at $VDD \geq 1.8V$ or (Vref applied voltage + 0.7V). Therefore, a VDD of more than 1.8V or (Vref applied voltage + 0.7V) is recommended when VDD is supplied from VIN or other power sources.

XC9106 / 07 Series

PWM Control, PWM/PFM Switching Control, Step-up DC/DC Converters

Preliminary

Externally Applied Reference Voltage (Vref)

ELECTRICAL CHARACTERISTICS

XC9106D003MR, XC9107D003MR

(FOSC=300 (kHz))

Ta=25°C

PARAMETER	SYMBOL	CONDITIONS	MIN.	TYP.	MAX.	UNITS	CIRCUIT
Output Voltage	VOUT	Vref = 0.9V	8.820	9.000	9.180	V	①
Reference Voltage Range	Vref		0.8		2.5	V	-
FB Control Voltage	VFB	Vref = 0.8V	0.784	0.800	0.816	V	④
		Vref = 0.9V	0.882	0.900	0.918		
		Vref = 2.5V	2.450	2.500	2.500		
*1 Power Supply Voltage Range	VDD	VDD as shown right or (Vref applied voltage + 0.7V)	1.8		10.0	V	-
Operation Start Voltage	VST1	Recommended Circuit using 2SD1628, IOU=1.0mA			0.9	V	③
*1 Oscillation Start Voltage	VST2	No external connections CE/Vref=0.9V, Voltage applied, FB=0V			0.8	V	④
Operation Holding Voltage	VHLD	Recommended Circuit using 2SD1628, IOU=1.0mA			0.7	V	③
Supply Current 1	IDD1	Same as VST2, VDD=3.300V		62	88	μA	④
Supply Current 2	IDD2	Same as IDD1, FB=1.2V		16	22	μA	④
Stand-by Current	ISTB	Same as IDD1, CE/Vref=0V			1.0	μA	⑤
Oscillation Frequency	FOSC	Same as IDD1	255	300	345	KHz	④
Maximum Duty Ratio	MAXDTY	Same as IDD1	75	81	87	%	④
PFM Duty Ratio	PFMDTY	No Load (XC9106 series)	24	32	40	%	①
Efficiency	EFFI	Recommended Circuit using XP161A1355		85		%	①
Soft-start Time	TSS	Vref=0.9V	5.0	10.0	20.0	mS	①
CE "High" Voltage	VCEH	Same as IDD1	0.65			V	⑤
CE "Low" Voltage	VCEL	Same as IDD1			0.20	V	⑤
EXT "High" ON Resistance	REXTH	Same as IDD1, VEXT=VOUT-0.4V		24	36	Ω	④
EXT "Low" ON Resistance	REXTL	Same as IDD1, VEXT=0.4V		16	24	Ω	④
CE "High" Current	ICEH	Same as IDD2, CE=0.8V	-1.0		0.0	μA	⑤
		Same as IDD2, CE=2.5V	0.0		2.5		
CE "Low" Current	ICEL	Same as IDD2, CE=0V			-0.1	μA	⑤
FB "High" Current	IFBH	Same as IDD2, FB=VDD			0.1	μA	⑤
FB "Low" Current	IFBL	Same as IDD2, FB=1.0V			-0.1	μA	⑤

Test Conditions: Unless otherwise stated, CL: ceramic, recommended MOS FET should be connected.

$$VDD = 3.30 \text{ (V)} \Rightarrow Vref = 0.09 \text{ (V)}, RFB1, 2 \times 10$$

$$VIN = 3.30 \text{ (V)} \Rightarrow IOU = 50 \text{ (mA)}$$

Notes 1* :

Although the IC starts step-up operations from a VDD of 0.8V, the output voltage and oscillation frequency are stabilized at VDD ≥ 1.8V or (Vref applied voltage + 0.7V). Therefore, a VDD of more than 1.8V or (Vref applied voltage + 0.7V) is recommended when VDD is supplied from VIN or other power sources.

TYPICAL APPLICATION CIRCUIT

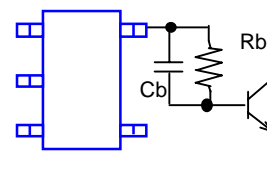
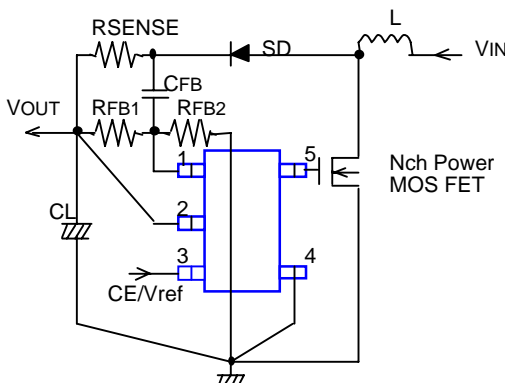

When obtaining VDD from a source other than VOUT, please insert a capacitor CDD between the VDD pin and the GND pin in order to provide stabler operations.

Please wire CL & CIN between the VOUT/VDD pin and the GND pin. Strengthen the wiring sufficiently. When using a capacitor other than ceramic or low ESR at CL, please take away RSENSE and short.

Insert Rb and Cb when using a bipolar NPN Transistor.

■ OPERATIONAL DESCRIPTION

The XC9106 / 07 series are reference voltage (Vref) apply external step-up DC/DC Controller ICs. Output voltage will be set with external resistors (RFB1 and 2) and Vref value. The series make it easy to control output voltage externally and are suited to software applications that need to vary voltage such as LCD power supply for PDA.

<Error Amp.>

Error Amplifier is designed to monitor the output voltage, comparing the feedback voltage (FB) with the reference voltage Vref. In response to feedback of a voltage lower than the reference voltage Vref, the output voltage of the error amp. decreases.

<OSC Generator>

This circuit generates the internal reference clock.

<Ramp Wave Generator>

The Ramp Wave Generator generates a saw-tooth waveform based on outputs from the OSC Generator.

<PWM Comparator>

The PWM Comparator compares outputs from the Error Amp. and saw-tooth waveform. When the voltage from the Error Amp's output is low, the external switch will be set to ON.

<PWM/PFM Controller>

This circuit generates PFM pulses.

The PWM/PFM automatic switching mode switches between PWM and PFM automatically depending on the load. PWM/PFM control turns into PFM control when threshold voltage becomes lower than voltage of error amps. Noise is easily reduced with PWM control since the switching frequency is fixed. Because of the function, control suited to the application can easily be selected. The series suitable for noise sensitive portable audio equipment as PWM control can suppress noise during operation and PWM/PFM switching control can reduce consumption current during light loads in stand-by.

<Vref 1 with Soft Start>

The reference voltage of the XC9106/9107 series is adjusted and fixed by external applied voltage. (For output voltage settings, please refer to the output voltage setting on page 7.)

To protect against inrush current, when the power is switched on, and also to protect against voltage overshoot, soft-start time is set internally to 10ms. It should be noted, however, that this circuit does not protect the load capacitor (CL) from inrush current. With the Vref voltage limited, and depending upon the input to error amp, the operation maintains a balance between the two inputs of error amps and controls the EXT pin's ON time so that it doesn't increase more than is necessary.

The XC9106/9107 series alters soft start times by the setting value of reference voltage in order to protect against voltage overshoot and also to protect against inrush current. Please determine soft start time by the formula equation.

$$TSS = 8.65 \times Vref + 2.21$$

[Example Computation]

$$Vref = 0.9V, TSS = 8.65 \times 0.9 + 2.21 = 10.0 \text{ ms}$$

XC9106 / XC9107D xxx MR

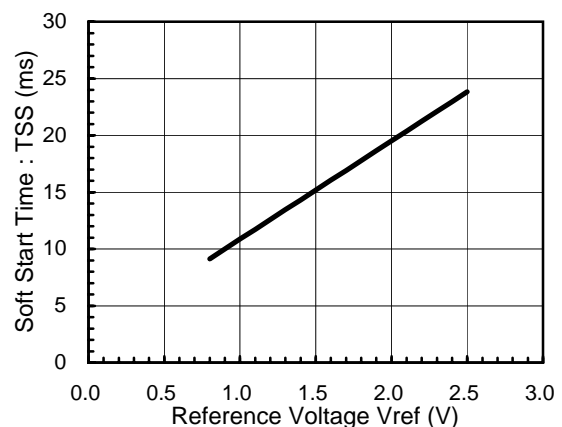

<Enable Function>

This function controls the operation and shutdown of the IC. When the voltage of the CE pin drops to 0.2V or less, disable mode will be entered, the IC's operations will stop and the EXT pin will be kept at a low level (the external N-type MOSFET will be OFF). When the IC is in a state of chip disable, current consumption will be no more than 1.0μA.

When the CE pin's voltage rises to 0.65V or more, enable mode will be entered and operations will recommence. The CE pin also doubles with reference voltage in the XC9106/9107 series, and the range of reference voltage can be varied externally from 0.8V to 2.5V.

■ FUNCTIONAL SETTINGS

< Output Voltage Setting >

Output voltage can be set by adding external split resistors. Output voltage is determined by the following equation, based on the values of RFB1 and RFB2. The sum of RFB1 and RFB2 should normally be 2 MΩ or less. The range of reference voltage of the series can be varied externally from 0.8V to 2.5V.

$$V_{OUT} = V_{ref} \text{ applied voltage} \times (R_{FB1} + R_{FB2}) / R_{FB2}$$

The value of CFB1, speed-up capacitor for phase compensation, should result in $f_{zfb} = 1 / (2 \pi \times C_{FB} \times R_{FB1})$ equal to 5 to 30kHz. Adjustments are required depending on the application, value of inductance (L), and value of load capacity (CL).

$f_{zfb} = 30\text{kHz}$ (L=10μH)	RFB1 : 270kΩ	RFB2 : 30kΩ
$f_{zfb} = 20\text{kHz}$ (L=22μH)	CFB : 20pF	($f_{zfb} = 30\text{kHz}$, L = 10μH)
$f_{zfb} = 10\text{kHz}$ (L=47μH)	27pF	($f_{zfb} = 20\text{kHz}$, L = 22μH)
	56pF	($f_{zfb} = 10\text{kHz}$, L = 47μH)

< The use of ceramic capacitor CL >

The circuit of the XC9106/9107 series is organized by a specialized circuit which reenacts negative feedback of both voltage and current. Also by insertion of approximately 100mΩ of a low and inexpensive sense resistor as current sense, a high degree of stability is possible even using a ceramic capacitor, a condition which used to be difficult to achieve. Compared to a tantalum condenser, because the series can be operated in a very small capacity, it is suited to use of the ceramic capacitor which is cheap and small.

■ RECOMMENDED COMPONENTS

Tr:	*When a MOSFET is used : 2SK2159 (NEC N-Channel Power MOSFET) Note* : With direct voltages over 4.5V, use the XP161A11A1PR.	*When a NPN Tr. Is used : 2SD1628 (Sanyo) Rb : 500Ω (adjust with Tr's HFE or load) Cb : 2200pF (ceramic type) $C_b \leq 1 / (2\pi \times R_b \times F_{OSC} \times 0.7)$
------------	--	---

SD: MA2Q737 (Schottky Diode type, MATSUSHITA)

L, CL : **Adjust as below according to the condition and peripheral components**

When Ceramic capacitor is used :

L :	22μH (SUMIDA CDRH5D28, FOSC = 100kHz) 10μH (SUMIDA CDRH5D18, FOSC = 300kHz)
CL :	10V 10μF (Ceramic capacitor, LMK325BJ106ML, TAIYOYUDEN) Use the formula below when step-up ratio and output current is large. $CL = (CL \text{ standard value}) \times (I_{OUT}(\text{mA}) / 300\text{mA} \times V_{OUT} / V_{IN})$
RSENSE :	100mΩ (FOSC = 300kHz) 50mΩ (FOSC = 100kHz)

When Tantalum capacitor is used :

L:	22μH (SUMIDA CDRH5D28, FOSC = 300kHz) 47μH (SUMIDA CDRH5D28, FOSC = 100kHz) Except when $I_{OUT}(\text{mA}) / 100\text{mA} \times V_{OUT} / V_{IN} > 2 \rightarrow 22\mu\text{H}$
CL:	16V 47μF (tantalum type NIPPONCHEMI 16MCE476MD2) Use the formula below when step-up ratio and output current is large. $CL = (CL \text{ standard value}) \times (I_{OUT}(\text{mA}) / 300\text{mA} \times V_{OUT} / V_{IN})$
RSENSE:	Not required, but short out the wire.

When AL Electrolytic capacitor is used :

L:	22μH (SUMIDA CDRH5D28, FOSC = 300kHz) 47μH (SUMIDA CDRH5D28, FOSC = 100kHz) Except when $I_{OUT}(\text{mA}) / 100\text{mA} \times V_{OUT} / V_{IN} > 2 \rightarrow 22\mu\text{H}$
CL:	16V 100μF (AL electrolytic type) + 10V 2.2μF (ceramic type) Strengthen appropriately when step-up ratio and output current is large.
RSENSE:	Not required, but short out the wire.
CFB:	Set up so that $f_{zfb} = 100\text{kHz}$.

Preliminary

Externally Applied Reference Voltage (Vref)

TEST CIRCUITS

Circuit ①

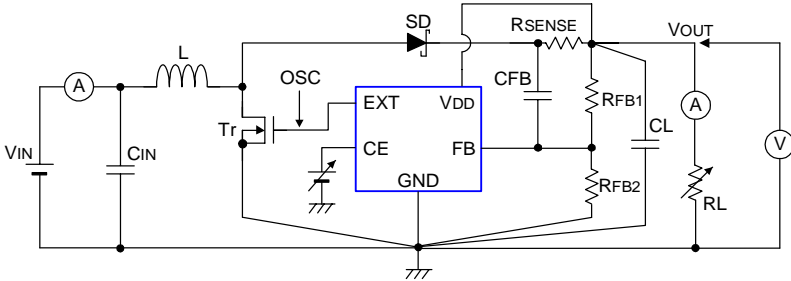

Circuit ④

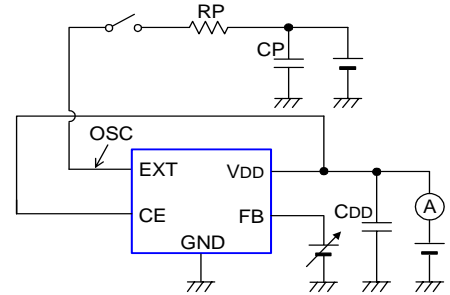

Circuit ②

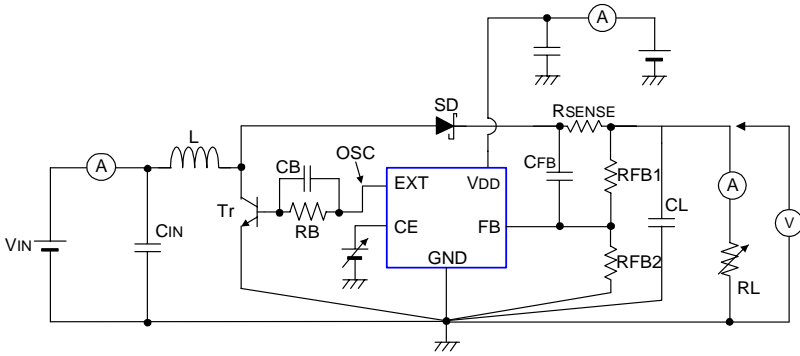

Circuit ⑤

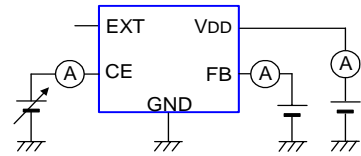

Circuit ③

