

XC9510 Series

Synchronous Step-Down DC/DC Converter with Built-In LDO Regulator In Series plus Voltage Detector

Preliminary

■ Input Voltage Range	2.4V ~ 6.0V
■ Output Voltage Range	DC/DC 0.9 ~ 4.0V ($\pm 2\%$)
	VR 0.9 ~ 4.0V ($\pm 2\%$)
	VD 0.9 ~ 5.0V ($\pm 2\%$)
■ Switching Frequency	300kHz, 600kHz, 1.2MHz
■ Output Current	DC/DC 800mA
	VR 600mA
■ Ultra Small Packages	SOP-8
■ Ceramic Capacitor Compatible	

■ GENERAL DESCRIPTION

The XC9510 series consists of a step-down DC/DC converter and a high-speed LDO regulator connected in series with the DC/DC converter's output. A voltage detector is also built-in. A highly efficient, low noise output is possible since the regulator is stepped-down further from the DC/DC output.

The DC/DC converter block incorporates a P-Channel driver transistor and a synchronous N-Channel switching transistor. With an external coil, diode and two capacitors, the XC9510 can deliver output currents up to 800mA at efficiencies over 90%. The XC9510 is designed for use with small ceramic capacitors.

A choice of three switching frequencies are available, 300 kHz, 600 kHz, and 1.2 MHz.

Output voltage settings for the DC/DC and VR are set-up internally in 0.1V steps within the range of 0.9V to 4.0V ($\pm 2.0\%$). For the VD, the range is of 0.9V to 5.0V ($\pm 2.0\%$).

The soft start time of the series is internally set to 5ms. With the built-in U.V.L.O. (Under Voltage Lock Out) function, the internal P-channel driver transistor is forced OFF when input voltage becomes 1.4 V or lower.

The operational states of the DC/DC and the regulator blocks can be changed by inputting three kinds of voltage level via the CE/MODE pin. The functions of the MODE pin can be selected via the external control pin to switch the DC/DC control mode and the disable pin to shut down the regulator block.

■ TYPICAL APPLICATION CIRCUIT

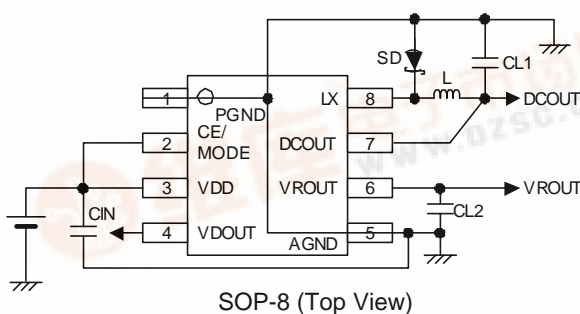

■ APPLICATIONS

- CD-R / RW, DVD
- HDD
- PDAs, portable communication modem
- Cellular phones
- Palmtop computers
- Cameras, video recorders

■ FEATURES

Input Voltage Range :	2.4V ~ 6.0V
Load Capacitors :	Ceramic Capacitors Compatible (Low ESR Capacitors)
VD Function :	Detects output voltage from the VDOUT pin while sensing either VDD, DCOUT, or VROUT internally. Nch Open Drain Output

<DC/DC Converter>

Output Voltage Range :	0.9 ~ 4.0V (Accuracy $\pm 2\%$)
Output Current :	800mA
Controls :	PWM Control PWM, PWM / PFM Automatic Switching External

Oscillation Frequency : 300kHz, 600kHz, 1.2MHz

<Regulator>

Output Voltage Range :	0.9 ~ 4.0V (Accuracy $\pm 2\%$)
Current Limit	600mA
Dropout Voltage :	240mV @ IOUT=300mA (VOUT=2.8V)
High Ripple Rejection	60dB @1kHz (VOUT=2.8V)

■ TYPICAL PERFORMANCE CHARACTERISTICS

XC9510Hxxxx

DC/DC Efficiency (DCOUT:3.4V, 1.2MHz), VR Efficiency (VROUT:3.0V)

VIN=5.0V, Topr=25°C, L:4.7uH(CDRH4D28C),
CIN:4.7uF(ceramic), CL1:10uF(ceramic), CL2:1uF(ceramic)

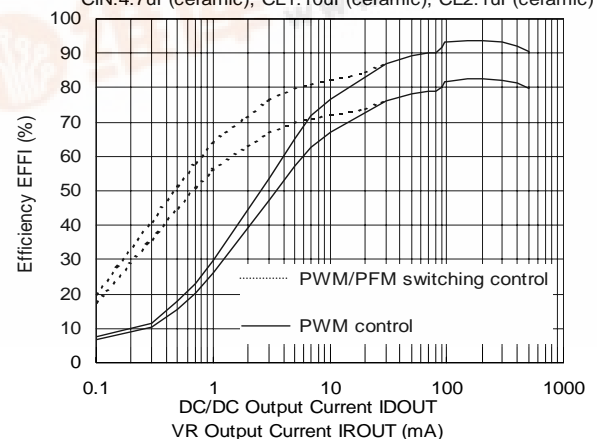

XC9510 Series

Synchronous Step-Down DC/DC Converter with Built-In LDO Regulator In Series plus Voltage Detector

Preliminary

■ PIN CONFIGURATION

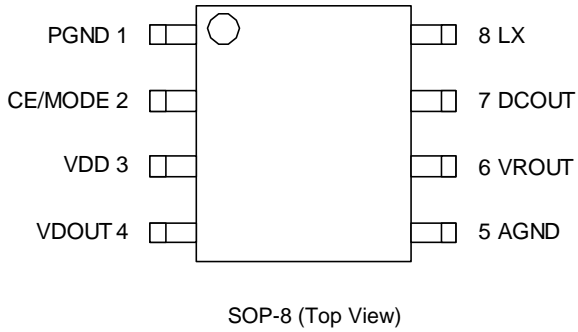

■ PIN ASSIGNMENT

PIN NUMBER	PIN NAME	FUNCTION
1	PGND	Power Ground
2	CE/MODE	Chip Enable / MODE Switch
3	VDD	Power Supply
4	VDOUT	VD Output
5	AGND	Analog Ground
6	VROUT	VR Output
7	DCOUT	DC/DC Output
8	LX	Switch

■ SELECTION GUIDE

- Ordering Information

XC9510 ①②③④⑤⑥ The input for the voltage regulator block comes from the DC/DC.

DESIGNATOR	SYMBOL	DESCRIPTION
①		Control Methods and MODE pins, the VD Sense pin (See the chart below)
②③		Setting voltage and specifications of each DC/DC, VR, and VD (Based on the internal standard)
④		Oscillation Frequency of DC/DC :
	3	300kHz
	6	600kHz
	C	1.2MHz
⑤	S	Package Type : SOP-8
⑥		Device Orientation :
	R	Embossed Tape : Standard feed
	L	Embossed Tape : Reverse feed

○ Control Methods, CE/MODE Pin, VDSSENSE

SERIES	①	DC/DC CONTROL METHODS	CE/MODE PINS (H LEVEL)	CE/MODE PINS (M LEVEL)	CE/MODE PINS (L LEVEL)	VD SENSE
XC9510	A	PWM Control	-	-	Stand-by Mode (Except for VD)	VDD
	B					DCOUT
	C					VROUT
	D					VDD
	E	VR : OFF	VR : ON	DCOUT		
	F			VROUT		
	H	PWM, PFM/PWM Manual Switch	PFM/PWM Automatic Switch	PWM Control	VDD	
	K				DCOUT	
L	VROUT					

XC9510 Series

Synchronous Step-Down DC/DC Converter with Built-In LDO Regulator In Series plus Voltage Detector

Preliminary

PACKAGING INFORMATION

- SOP-8

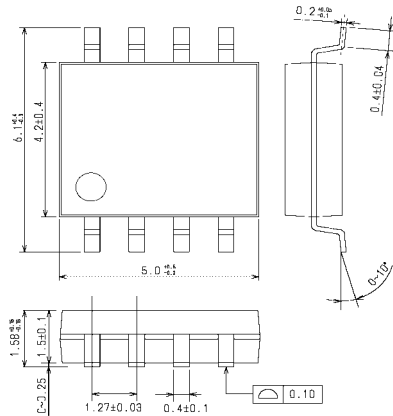

BLOCK DIAGRAM

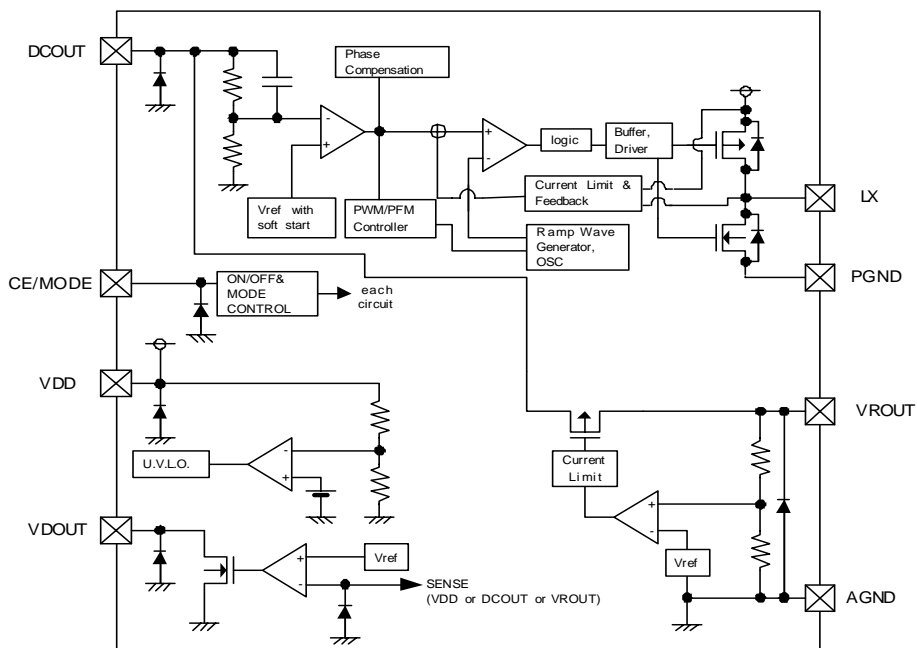

* Diodes shown in the above circuits are protective diodes.

ABSOLUTE MAXIMUM RATINGS

Ta=25°C

PARAMETER	SYMBOL	RATINGS	UNITS
VDD Pin Voltage	AVDD	- 0.3 ~ 6.5	V
DCOUT Pin Voltage	DCOUT	- 0.3 ~ VDD + 0.3	V
VROUT Pin Voltage	VROUT	- 0.3 ~ VDD + 0.3	V
VDOUT Pin Voltage	VDOUT	- 0.3 ~ VDD + 0.3	V
LX Pin Voltage	LX	- 0.3 ~ VDD + 0.3	V
CE/MODE Pin Voltage	CE/MODE	- 0.3 ~ VDD + 0.3	V
Continuous Power Dissipation (*1)	SOP-8 Pd	650	mW
Operating Temperature Range	Topr	- 40 ~ + 85	°C
Storage Temperature Range	Tstg	- 55 ~ + 125	°C

(*1) $I_{OUT} = P_d / (V_{IN} - V_{OUT})$ when PC board mounting.

(*2) Package power dissipation

XC9510 Series

Synchronous Step-Down DC/DC Converter with Built-In LDO Regulator In Series plus Voltage Detector

Preliminary

ELECTRICAL CHARACTERISTICS

XC9510HxxCSx

○ Common Characteristics

Ta=25°C

PARAMETER	SYMBOL	CONDITIONS	MIN.	TYP.	MAX.	UNITS	TEST CIRCUIT
Supply Current 1	IDD1	VIN=CE=DCOUT=5.0V	-	300	-	μA	①
Supply Current 2	IDD2	VIN=CE=5.0V, DCOUT=0V	-	240	-	μA	①
Stand-by Current (note 1)	ISTB	VIN=6.5V, CE=0V	-	0.6	2.5	μA	①
Input Voltage Range	VIN		2.4	-	6.0	V	-
U.V.L.O. Voltage (note 2)	VUVLO		1.00	1.40	1.78	V	③
CE 'H' Level Voltage	VCEH		0.6	-	VDD	V	③
CE 'M' Level Voltage	VCEM		-	-	VDD-1.2	V	③
CE 'L' Level Voltage	VCEL		VSS	-	0.25	V	③
CE 'H' Level Current	ICEH		-0.1	-	0.1	μA	①
CE 'L' Level Current	ICEL		-0.1	-	0.1	μA	①

○ DC/DC Converter (2.2V product)

Ta=25°C

PARAMETER	SYMBOL	CONDITIONS	MIN.	TYP.	MAX.	UNITS	TEST CIRCUIT
Output Voltage	DCOUT	Connected to the external components, IDOUT=30mA	2.156	2.200	2.244	V	③
Oscillation Frequency	FOSC	Connected to the external components, IDOUT=10mA	1.02	1.20	1.38	MHz	③
Maximum Duty Ratio	MAXDUTY	DCOUT=0V	100	-	-	%	④
Minimum Duty Ratio	MINDUTY	DCOUT=VIN	-	-	0	%	④
PFM Duty Ratio	PFMDUTY	Connected to the external components, No Load	21	30	38	%	③
LX SW 'High' On Resistance (note 3)	RLXH	DCOUT=0V, LX=VIN-0.05V	-	0.5	-	Ω	⑤
LX SW 'Low' On Resistance	RLXL		-	0.5	-	Ω	-
Maximum Output Current	IMAX1		800	-	-	mA	③
Current Limit	ILIM1		-	1.2	-	A	⑥
Efficiency (note 4)	EFFI	Connected to the external components, IDOUT=100mA	-	90	-	%	③
Output Voltage Temperature Characteristics	$\frac{\Delta VOUT}{\Delta T_{opr}} \cdot VOUT$	IDOUT=30mA -40°C ≤ Topr ≤ 85°C	-	±100	-	ppm/°C	③
Soft Start Time	TSS	Connected to the external components, CE=0V ⇒ VIN, IDOUT=1mA	-	5	-	mS	③
Latch Time (note 5)	Tlat	Connected to the external components, VIN=CE=5.0V, Short DCOUT by 1Ω resistor	-	8	-	mS	③

○ Regulator (1.8V product)

Ta=25°C

PARAMETER	SYMBOL	CONDITIONS	MIN.	TYP.	MAX.	UNITS	TEST CIRCUIT
Output Voltage	VROUT(E)	IROUT=30mA	1.764	1.800	1.836	V	②
Maximum Output Current	IMAX2		200	-	-	mA	②
Load Regulation	Δ VROUT	1mA ≤ IROUT ≤ 100mA	-	15	50	mV	②
Dropout Voltage 1 (note 6)	Vdif 1	IROUT=30mA	-	30	-	mV	②
Dropout Voltage 2	Vdif 2	IROUT=100mA	-	85	-	mV	②
Line Regulation	$\frac{\Delta VROUT}{\Delta VIN} \cdot VROUT$	IROUT=30mA VROUT(T)+1V ≤ VIN ≤ 6V	-	0.2	-	%/V	②
Current Limit	ILIM2	VROUT=VROT(E)x0.9	-	600	-	mA	⑦
Short-Circuit Current	ISHORT	VROUT=VSS	-	30	-	mA	⑦
Ripple Rejection Rate	PSRR	VIN={VOUT(T) + 1.0} VDC + 0.5Vp-pAC IROUT=30mA, f=1kHz	-	60	-	dB	②
Output Voltage Temperature Characteristics	$\frac{\Delta VROUT}{\Delta T_{opr}} \cdot VROUT$	IROUT=30mA -40°C ≤ Topr ≤ 85°C	-	±100	-	ppm/°C	②

XC9510 Series

Synchronous Step-Down DC/DC Converter with Built-In LDO Regulator In Series plus Voltage Detector

Preliminary

■ ELECTRICAL CHARACTERISTICS (Continued)

○ Detector (2.7V product)

Ta=25°C

PARAMETER	SYMBOL	CONDITIONS	MIN.	TYP.	MAX.	UNITS	TEST CIRCUIT
Detect Voltage	VDF		2.646	2.700	2.754	V	⑧
Hysteresis Range	VHYS		3	5	8	%	-
VD Output Current	IVD	VDOUT=0.5V	1	-	-	mA	⑨
Output Voltage Temperature Characteristics	$\frac{\Delta VDF}{\Delta T_{opr}} \cdot VDF$	-40°C ≤ T _{opr} ≤ 85°C	-	±100	-	ppm /°C	⑧

Test Conditions : Unless otherwise stated; * VROUT(T) : Setting Output Voltage
 DC/DC : VIN=3.6V [@ DCOU=2.2V]
 VD : VIN=6.0V
 VR : VIN = VROUT(T) + 1.0 (V) [When VROUT(T) ≤ 1.4V, VIN =2.4V]

note 1 : VD operates when in stand-by mode.

note 2 : Including hysteresis operating voltage range.

note 3 : On resistance = 0.05V / ILX

note 4 : EFF1 = { (Output Voltage x Output Current) / (Input Voltage x Input Current) } x 100

note 5 : Time until it short-circuits DCOU with GND through 1Ω of resistance from a state of operation
 and is set to DCOU=0V from current limit pulse generating.

note 6 : Vdif = (VIN1^(note 7) - VROUT1^(note 8))

note 7 : VIN 1 = The input voltage when VROUT1 appears as input voltage is gradually decreased.

note 8 : VROUT1 = A voltage equal to 98% of the output voltage whenever an amply stabilized IOU {VROUT(T) + 1.0V} is input.

XC9510 Series

Synchronous Step-Down DC/DC Converter with Built-In LDO Regulator In Series plus Voltage Detector

Preliminary

TEST CIRCUITS

Circuit ① Supply Current, Stand-by Current, CE Current

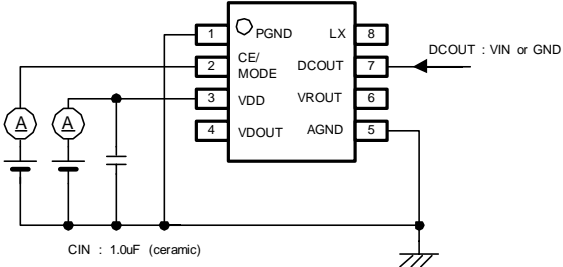

Circuit ② Output Voltage (VR), Load Stability, Dropout Voltage, CE Current (MODE Current)

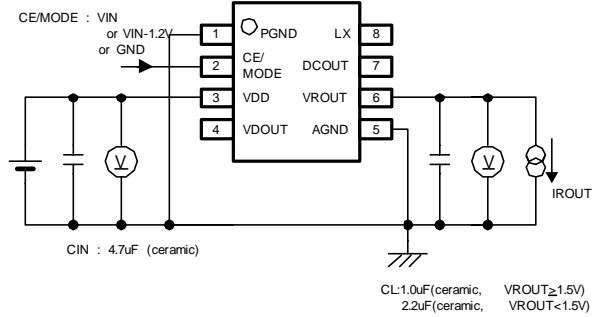

Circuit ③ Output Voltage (DC/DC) Oscillation Frequency, U.V.L.O. Voltage, Softstart Time, Latch Time, CE Voltage, (PFM Duty Cycle), (MODE Voltage)

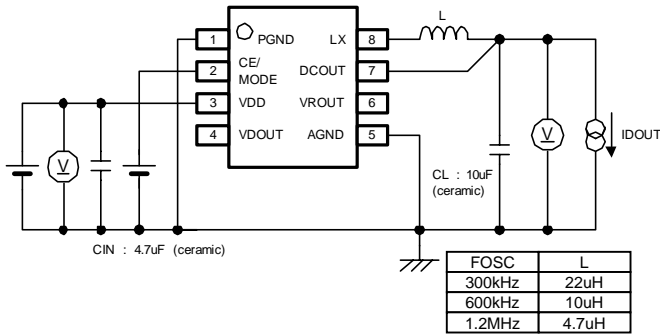

Circuit ④ Minimum Duty Cycle, Maximum Duty Cycle

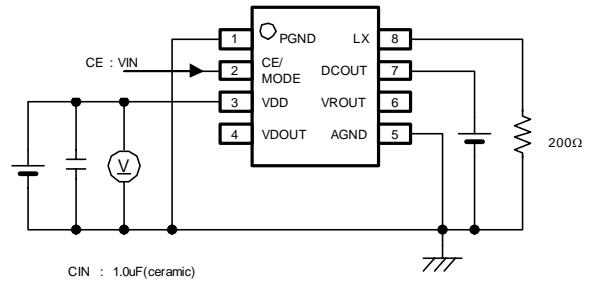

Circuit ⑤ Lx ON Resistance

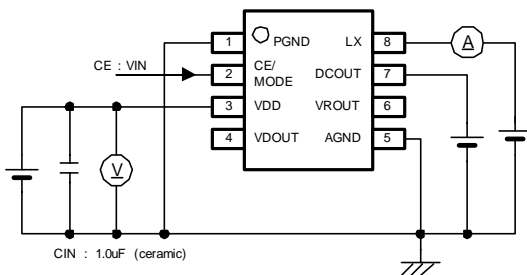

Circuit ⑥ Current Limit 1 (DC/DC)

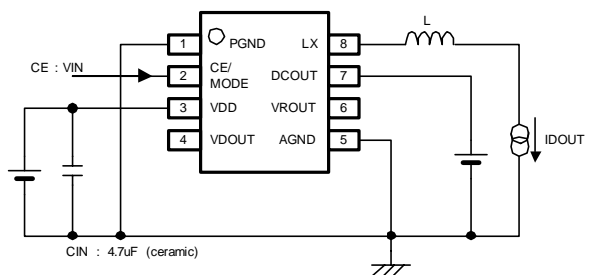

Circuit ⑦ Current Limit 2 (VR), Short Protection (VR)

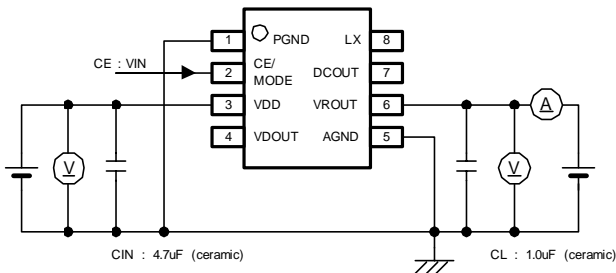

Circuit ⑧ Detect Voltage, Release Voltage

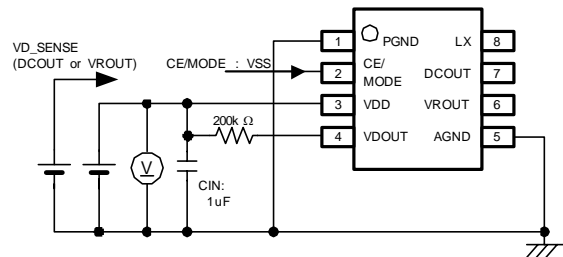

Circuit ⑨ VD Output Current

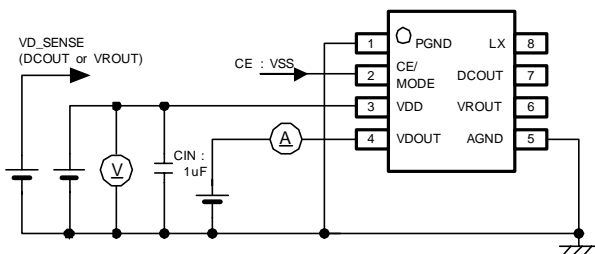

XC9510 Series

Synchronous Step-Down DC/DC Converter with Built-In LDO Regulator In Series plus Voltage Detector

Preliminary

■ TYPICAL APPLICATION CIRCUIT

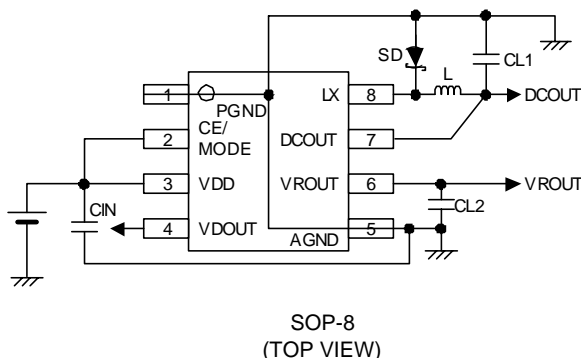

FOSC	L
1.2MHz	4.7 μ H (CDRH4D28C, SUMIDA)
600kHz	10 μ H (CDRH4D28C, SUMIDA)
300kHz	22 μ H (CDRH4D28C, SUMIDA)

CIN : 4.7 μ F (ceramic, TAIYO-YUDEN)
CL1 : 10 μ F (ceramic, TAIYO-YUDEN)
CL2 : 1 μ F (ceramic, TAIYO-YUDEN), VROUT \geq 1.5V
: 2.2 μ F (ceramic, TAIYO-YUDEN), VROUT<1.5V

■ OPERATIONAL EXPLANATION

The XC9510 series consists of a synchronous step-down DC/DC converter, a high speed LDO voltage regulator, and a voltage detector. Since the LDO voltage regulator is stepped-down from the DC/DC's output, high efficiency and low noise is possible even at lower output voltages.

○ DC/DC Converter

The series consists of a reference voltage source, ramp wave circuit, error amplifier, PWM comparator, phase compensation circuit, output voltage adjustment resistors, driver transistor, synchronous switch, current limiter circuit, U.V.L.O. circuit and others. The series ICs compare, using the error amplifier, the voltage of the internal voltage reference source with the feedback voltage from the VOUT pin through split resistors. Phase compensation is performed on the resulting error amplifier output, to input a signal to the PWM comparator to determine the turn-on time during PWM operation. The PWM comparator compares, in terms of voltage level, the signal from the error amplifier with the ramp wave from the ramp wave circuit, and delivers the resulting output to the buffer driver circuit to cause the Lx pin to output a switching duty cycle. This process is continuously performed to ensure stable output voltage. The current feedback circuit monitors the P-channel MOS driver transistor current for each switching operation, and modulates the error amplifier output signal to provide multiple feedback signals. This enables a stable feedback loop even when a low ESR capacitor, such as a ceramic capacitor, is used, ensuring stable output voltage.

< Reference Voltage Source >

The reference voltage source provides the reference voltage to ensure stable output voltage of the DC/DC converter.

< Ramp Wave Circuit >

The ramp wave circuit determines switching frequency. The frequency is fixed internally and can be selected from 300kHz, 600 kHz and 1.2 MHz. Clock pulses generated in this circuit are used to produce ramp waveforms needed for PWM operation, and to synchronize all the internal circuits.

< Error Amplifier >

The error amplifier is designed to monitor output voltage. The amplifier compares the reference voltage with the feedback voltage divided by the internal split resistors. When a voltage lower than the reference voltage is fed back, the output voltage of the error amplifier increases. The gain and frequency characteristics of the error amplifier output are fixed internally to deliver an optimized signal to the mixer.

< PWM/PFM >

The XC9510A to F series are PWM control, while the XC9510H to L series can be automatically switched between PWM control and PWM/PFM control. The PWM mode of the XC9510A to F series are controlled on a specified frequency from light loads through the heavy loads. Since the frequency is specified, the composition of a noise filter etc. becomes easy. However, the efficiency at the time of the light load may become low.

The XC9510H to L series can switch in any timing between PWM control and PWM/PFM automatic switching control. The series can not control only PFM mode. If needed, the operation can be set on a specified frequency; therefore, the control of the noise etc. is possible and the high efficiency at the time of the light load during PFM control mode is possible. With the automatic PWM/PFM switching control function, the series ICs are automatically switched from PWM control to PFM control mode under light load conditions. If during light load conditions the coil current becomes discontinuous and on-time rate falls lower than 30%, the PFM circuit operates to output a pulse with 30% of a fixed on-time rate from the Lx pin. During PFM operation with this fixed on-time rate, pulses are generated at different frequencies according to conditions of the moment. This causes a reduction in the number of switching operations per unit of time, resulting in efficiency improvement under light load conditions. However, since pulse output frequency is not constant, consideration should be given if a noise filter or the like is needed.

Necessary conditions for switching to PFM operation depend on input voltage, load current, coil value and other factors.

XC9510 Series

Synchronous Step-Down DC/DC Converter with Built-In LDO Regulator In Series plus Voltage Detector

Preliminary

OPERATIONAL EXPLANATION (Continued)

< Synchronous / Non-synchronous >

The XC9510 series automatically switches synchronous / non synchronous according to the state of the DC/DC converter.

In the series, highly efficient operation using the synchronous mode while the coil current is in a continuation state.

The series enters non-synchronous operation when the built-in Nch switching transistor for synchronous operation is shutdown which happens when the load current becomes low and the operation changes to a discontinuous state.

The IC can operate without an external schottky diode because the parasitic diode in the Nch switching transistor provides the circuit's step-down operation. However, since V_f of the parasitic diode is high 0.6V, the efficiency level during non-synchronous operation shows a slight decrease. Please use an external schottky diode if high efficiency is required during light load current.

○ Continuous Mode : Synchronous

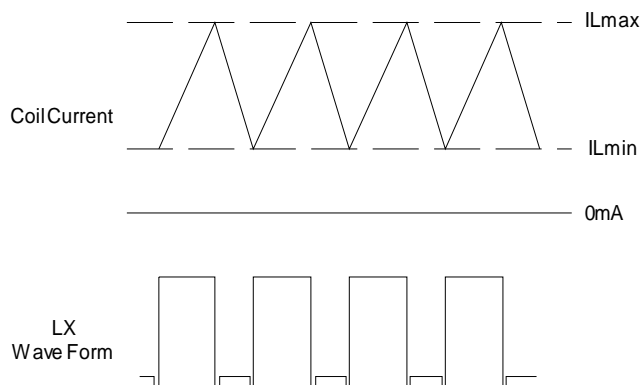

○ Discontinuous Mode : Non-Synchronous

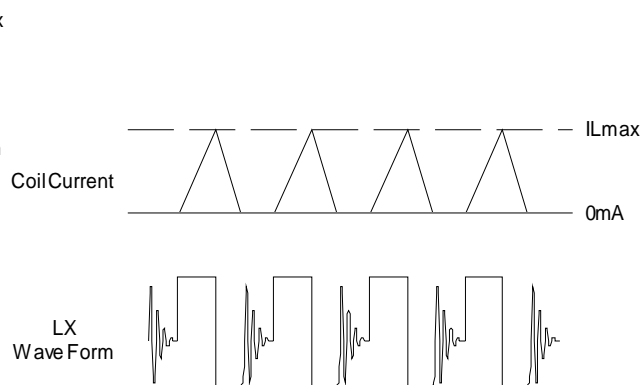

< Current Limit >

The current limiter circuit of the XC9510 series monitors the current flowing through the P-channel MOS driver transistor connected to the Lx pin, and features a combination of the constant-current type current limit mode and the operation suspension mode.

- ① When the driver current is greater than a specific level, the constant-current type current limit function operates to turn off the pulses from the Lx pin at any given timing.
- ② When the driver transistor is turned off, the limiter circuit is then released from the current limit detection state.
- ③ At the next pulse, the driver transistor is turned on. However, the transistor is immediately turned off in the case of an over current state.
- ④ When the over current state is eliminated, the IC resumes its normal operation.

The IC waits for the over current state to end by repeating the steps ① through ③. If an over current state continues for 8msec and the above three steps are repeatedly performed, the IC performs the function of latching the OFF state of the driver transistor, and goes into operation suspension mode. Once the IC is in suspension mode, operations can be resumed by either turning the IC off via the CE/MODE pin, or by restoring power to the VIN pin. The suspension mode does not mean a complete shutdown, but a state in which pulse output is suspended; therefore, the internal circuitry remains in operation. The constant-current type current limit of the XC9510 series can be set at 1.2A.

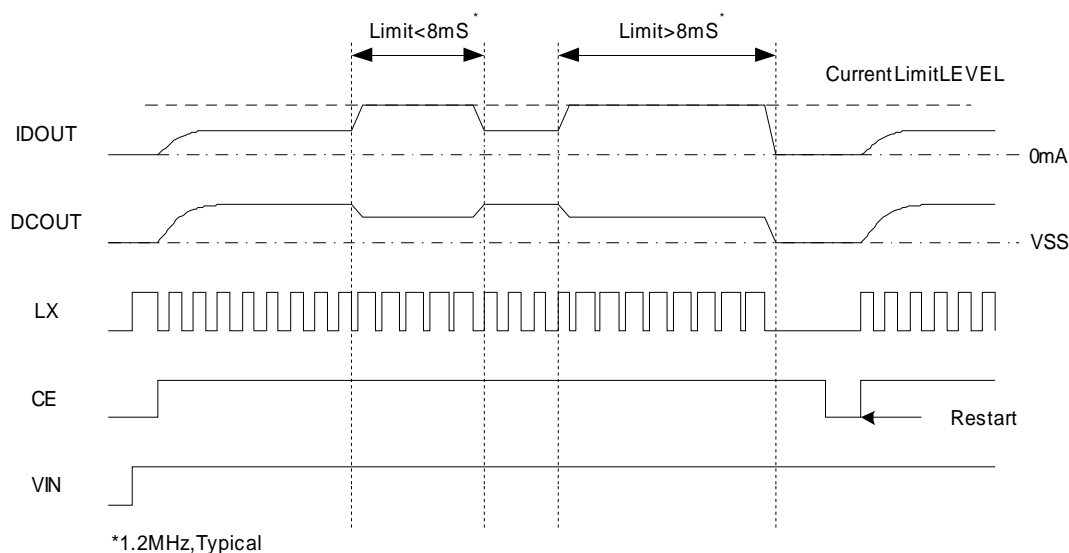

*1.2MHz, Typical

XC9510 Series

Synchronous Step-Down DC/DC Converter with Built-In LDO Regulator In Series plus Voltage Detector

Preliminary

■ OPERATIONAL EXPLANATION (Continued)

< U.V.L.O. Circuit >

When the VIN pin voltage becomes 1.4 V or lower, the P-channel output driver transistor is forced OFF to prevent false pulse output caused by unstable operation of the internal circuitry. When the VIN pin voltage becomes 1.8 V or higher, switching operation takes place. By releasing the U.V.L.O. function, the IC performs the soft start function to initiate output startup operation. The soft start function operates even when the VIN pin voltage falls momentarily below the U.V.L.O. operating voltage. The U.V.L.O. circuit does not cause a complete shutdown of the IC, but causes pulse output to be suspended; therefore, the internal circuitry remains in operation.

○ High Speed LDO Voltage Regulator

The voltage regulator block of the XC9510 series consists of a reference voltage source, error amplifier, and current limiter circuit.

The voltage divided by split resistors is compared with the internal reference voltage by the error amplifier. The P-Channel MOSFET, which is connected to the VROUT pin, is then driven by the subsequent output signal. The output voltage at the VROUT pin is controlled and stabilized by a system of negative feedback. A stable output voltage is achievable even if used with low ESR capacitors as a phase compensation circuit is built-in.

< Reference Voltage Source >

The reference voltage source provides the reference voltage to ensure stable output voltage of the regulator.

< Error Amplifier >

The error amplifier compares the reference voltage with the signal from VROUT, and the amplifier controls the output of the Pch driver transistor.

<Current Limit Circuit>

The voltage regulator block includes a combination of a constant current limiter circuit and a foldback circuit. When the load current reaches the current limit level, the current limiter circuit operates and the output voltage of the voltage regulator block drops. As a result of this drop in output voltage, the foldback circuit operates, output voltage drops further and the load current decreases. When the VROUT and GND pin are shorted, the load current of about 30mA flows.

○ Detector

The detector block of the XC9510 series detects output voltage from the VDOUT pin while sensing either VDD, DCOUT, or VROUT internally.

(N channel Open Drain Type)

<CE/MODE Pin Function>

The operation of the XC9510 series' DC/DC converter block and voltage regulator block will enter into the shut down mode when a low level signal is input to the CE/MODE pin. During the shut down mode, the current consumption occurs only in the detector and is 0.6 μ A (TYP.), with a state of high impedance at the Lx pin and DCOUT pin. The IC starts its operation by inputting a high level signal or a middle level signal to the CE/MODE pin. The input to the CE/MODE pin is a CMOS input and the sink current is 0 μ A (TYP.).

The operation of the XC9510D to F series' voltage detector block will enter into stand-by mode when a high level signal is input to the CE/MODE pin. The voltage regulator block will operate when a middle level signal is input. But when a low level signal is input, the voltage regulator block will enter into stand-by mode. With the XC9510H to L series control can be PWM control when the CE/MODE pin is 'M' level and PWM/PFM automatic switching control when the CE/MODE pin is 'H' level.