



XR-215A

Monolithic
Phase-Locked Loop

June 1997-3

FEATURES

- Wide Frequency Range: 0.5Hz to 25MHz
- Wide Supply Voltage Range: 5V to 26V
- Wide Dynamic Range: 300µV to 3V, nominally
- ON-OFF Keying and Sweep Capability
- Wide Tracking Range: Adjustable from ±1% to ±50%
- High-Quality FM Detection: Distortion 0.15%
Signal/Noise 65dB

APPLICATIONS

- FM Demodulation
- Frequency Synthesis
- FSK Coding/Decoding (MODEM)
- Tracking Filters
- Signal Conditioning
- Tone Decoding
- Data Synchronization
- Telemetry Coding/Decoding
- FM, FSK and Sweep Generation
- Crystal-Controlled PLL
- Wideband Frequency Discrimination
- Voltage-to-Frequency Conversion

GENERAL DESCRIPTION

The XR-215A is a highly versatile monolithic phase-locked loop (PLL) system designed for a wide variety of applications in both analog and digital communication systems. It is especially well suited for FM or FSK demodulation, frequency synthesis and tracking filter

applications. The XR-215A can operate over a large choice of power supply voltages ranging from 5V to 26V and a wide frequency band of 0.5Hz to 25MHz. It can accommodate analog signals between 300mV and 3V.

ORDERING INFORMATION

Part No.	Package	Operating Temperature Range
XR-215ACP	16 Lead 300 Mil PDIP	0°C to 70°C
XR-215ACD	16 Lead SOIC (Jedec, 0.300")	0°C to 70°C



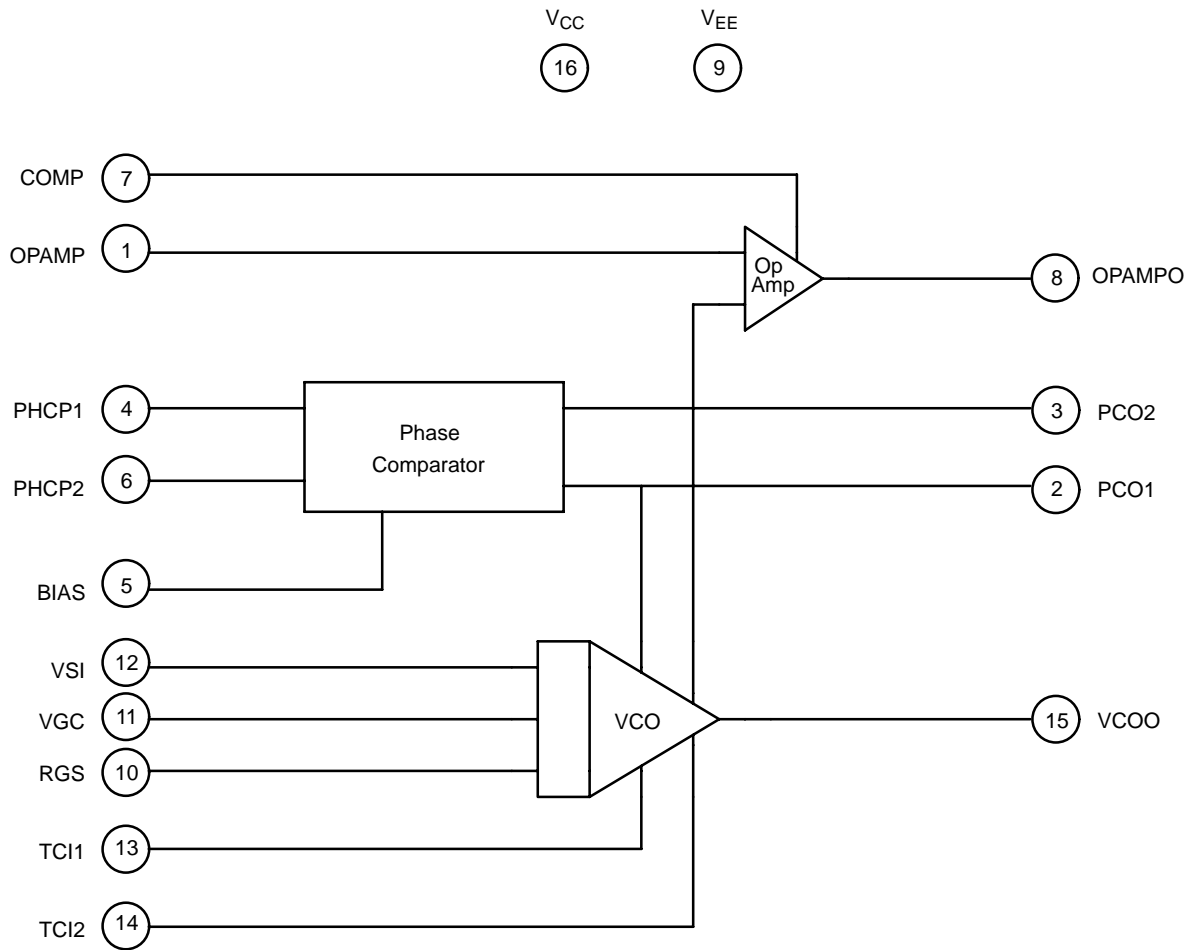
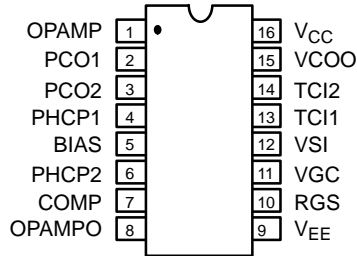
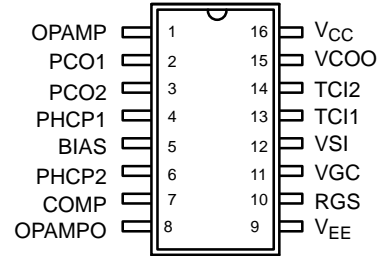

Figure 1. XR-215A Block Diagram

PIN CONFIGURATION



16 Lead 300 Mil PDIP



16 Lead SOIC (Jedec, 0.300")

PIN DESCRIPTION

Pin #	Symbol	Type	Description
1	OPAMP	I	Operational Amplifier Input.
2	PCO1	O	Phase Comparator Output 1.
3	PCO2	O	Phase Comparator Output 2.
4	PHCP1	I	Phase Comparator Input 1.
5	BIAS	I	Phase Comparator Bias Input.
6	PHCP2	I	Phase Comparator Input 2.
7	COMP	I	Operational Amplifier Frequency Compensation Input.
8	OPAMPO	O	Operational Amplifier Output.
9	V _{EE}	-	Negative Power Supply.
10	RGS	I	Range Select Input.
11	VGC	I	VCO Gain Control.
12	VSI	I	VCO Sweep Voltage Input.
13	TCI1	I	Timing Capacitor Input. The timing capacitor connects between this pin and pin 14.
14	TCI2	I	Timing Capacitor Input. The timing capacitor connects between this pin and pin 13.
15	VCOO	O	VCO Output.
16	V _{CC}	-	Positive Power Supply.

DC ELECTRICAL CHARACTERISTICS

Test Conditions: $V_{CC} = 12V$ (single supply), $T_A = 25^\circ C$, Test Circuit of *Figure 3* with $C_0 = 100\text{ pF}$, (silver-mica) S_1, S_2, S_5 , closed, S_3, S_4 open unless otherwise specified.

Parameter	Min.	Typ.	Max.	Unit.	Conditions
GENERAL CHARACTERISTICS					
Supply Voltage					
Single Supply	5		26	V	<i>Figure 3</i>
Split Supply	± 2.5		± 13	V	<i>Figure 4</i>
Supply Current	8	11	15	mA	<i>Figure 3</i>
Upper Frequency Limit	20	25		MHz	<i>Figure 3</i> , S_1 Open, S_4 Closed
Lowest Practical Operating Frequency		0.5		Hz	$C_0 = 500\mu F$ (Non-Polarized)
VCO Section					
Stability:					
Temperature		250	600	ppm/ $^\circ C$	See <i>Figure 7</i> , $0^\circ C \leq T_T < 70^\circ C$
Power Supply		0.1		%/V	$V_{CC} > 10V$
Sweep Range	5:1	8:1			S_3 Closed, S_4 Open, $0 < V_S < 6V$ See <i>Figure 10</i> , $C_0 = 2000\text{ pF}$
Output Voltage Swing	1.5	2.5		Vp-p	S_5 Open
Rise Time		20		ns	
Fall Time		30		ns	10pF to Ground at Pin 15
Phase Comparator Section					
Conversion Gain		2		V/rad	$V_{IN} > 50\text{ mV rms}$ (See Characteristic Curves)
Output Impedance		6		k Ω	Measured Looking into Pins 2 or 3
Output Offset Voltage		20	100	mV	Measured Across Pins 2 and 3 $V_{IN} = 0$, S_5 Open
OP AMP Section					
Open Loop Voltage Gain	66	80		dB	S_2 Open
Slew Rate		2.5		V/ μsec	$A_V = 1$
Input Impedance	0.5	2		M Ω	
Output Impedance		2		k Ω	
Output Swing	7	10		Vp-p	$R_L = 30\text{ k}\Omega$ From Pin 8 to Ground
Input Offset Voltage		1	10	mV	
Input Bias Current		80		nA	
Common Mode Rejection		90		dB	

Note:

Bold face parameters are covered by production test and guaranteed over operating temperature range.

DC ELECTRICAL CHARACTERISTICS (CONT'D)

Parameter	Min.	Typ.	Max.	Unit	Conditions
SPECIAL APPLICATIONS					
A) FM Demodulation					
Test Conditions: Test circuit of <i>Figure 5</i> , $V_{CC} = 12V$, input signal = 10.7MHz FM with $\Delta f = 75kHz$. $f_{mod} = 1kHz$.					
Detection Threshold		0.8	3	mV rms	50Ω source
Demodulated Output Amplitude		500		mV rms	Measured at Pin 8
Distortion (THD)		0.15	0.5	%	
AM Rejection		40		dB	$V_{IN} = 10mV$ rms, 30% AM
Output Signal/Noise		65		dB	
B) Tracking Filter					
Test Conditions: Test circuit of <i>Figure 6</i> , $V_{CC} = 12V$, $f_o = 1 MHz$, $V_{IN} = 100mV$ rms, 50Ω source .					
Tracking Range (% of f_o)		± 50			See <i>Figure 5</i> and <i>Figure 25</i>
Discriminator Output					
$\frac{\Delta V_{OUT}}{\Delta f / f_o}$		50		mV/%	Adjustable - See Applications Information

Note:

Bold face parameters are covered by production test and guaranteed over operating temperature range.

Specifications are subject to change without notice

ABSOLUTE MAXIMUM RATINGS

Power Supply	26 volts	SOIC Package	500mW
Power Dissipation (Package Limitation)		Derate above 25°C	4mW/°C
Plastic Package	625mW	Temperature	
Derate above 25°C	5mW/°C	Storage	-65°C to +150°C

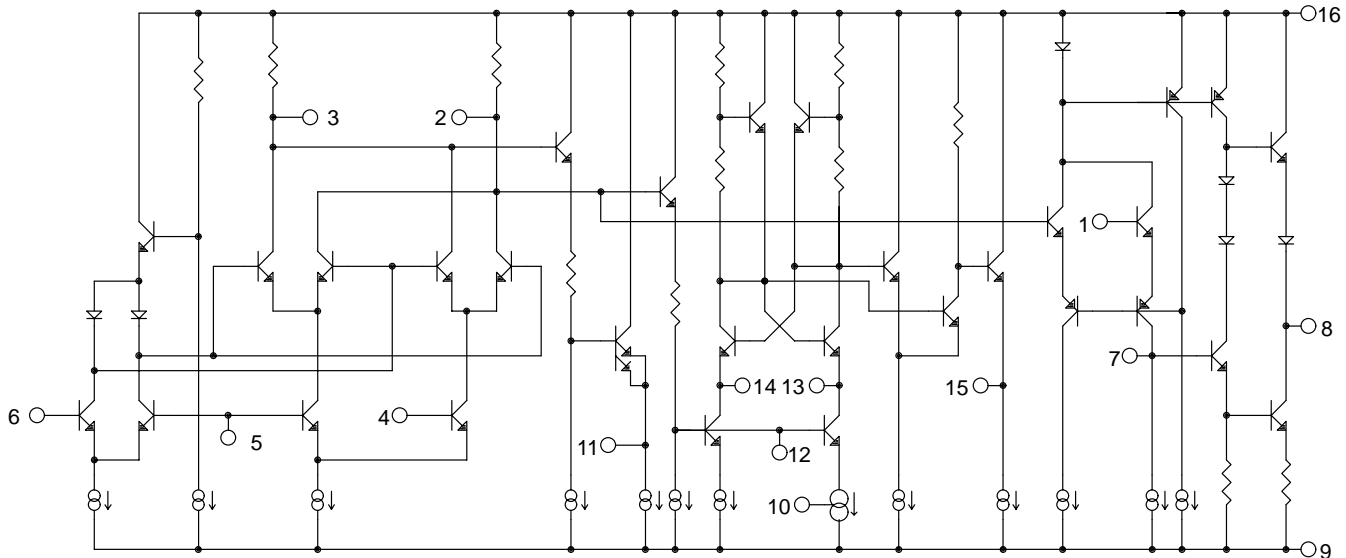

Figure 2. Equivalent Schematic Diagram

SYSTEM DESCRIPTION

The XR-215A monolithic PLL system consists of a balanced phase comparator, a highly stable voltage-controlled oscillator (VCO) and a high speed operational amplifier. The phase comparator outputs are internally connected to the VCO inputs and to the noninverting input of the operational amplifier. A self-contained PLL System is formed by simply AC coupling the VCO output to either of the phase comparator inputs and adding a low-pass filter to the phase comparator output terminals.

The VCO section has frequency sweep, on-off keying, sync, and digital programming capabilities. Its frequency is highly stable and is determined by a single external capacitor. The operational amplifier can be used for audio preamplification in FM detector applications or as a high speed sense amplifier (or comparator) in FSK demodulation.

DESCRIPTION OF CIRCUIT CONTROLS

Phase Comparator Inputs (Pins 4 and 6)

One input to the phase comparator is used as the signal input. The remaining input should be AC coupled to the

VCO output (pin 15) to complete the PLL (see *Figure 3*). For split supply operation, these inputs are biased from ground as shown in *Figure 4*. For single supply operation, a resistive bias string similar to that shown in *Figure 3* should be used to set the bias level at approximately $V_{CC}/2$. The DC bias current at these terminals is nominally $8\mu A$.

Phase Comparator Bias (Pin 5)

This terminal should be DC biased as shown in *Figure 3* and *Figure 4*, and AC grounded with a bypass capacitor.

Phase Comparator Outputs (Pins 2 and 3)

The low frequency (or DC) voltage across these pins corresponds to the phase difference between the two signals at the phase comparator inputs (pins 4 and 6). The phase comparator outputs are internally connected to the VCO control terminals (see *Figure 2*.) One of the outputs (pin 3) is internally connected to the noninverting input of the operational amplifier. The low-pass filter is achieved by connecting an RC network to the phase comparator outputs as shown in *Figure 15*.

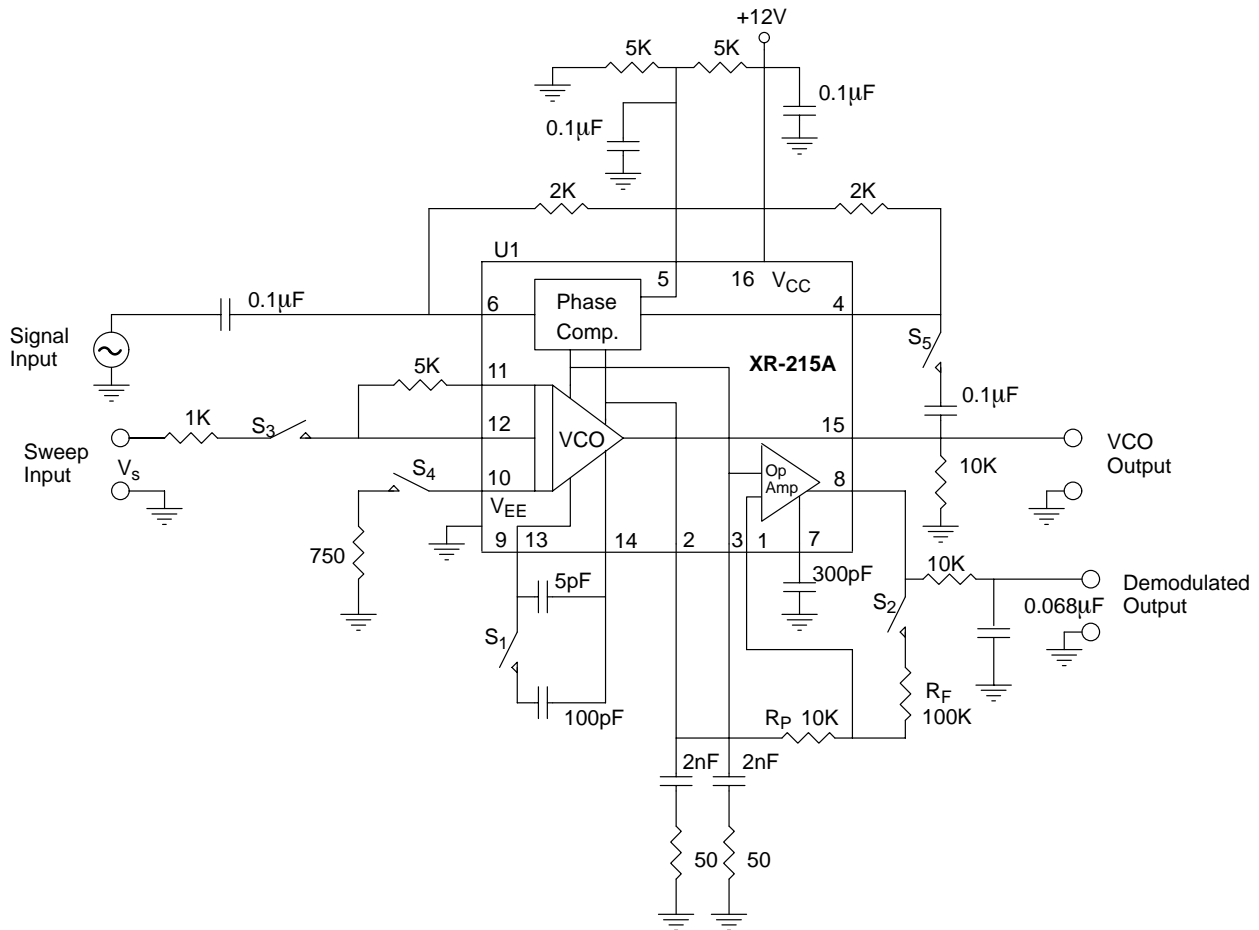

Figure 3. Test Circuit for Single Supply Operation

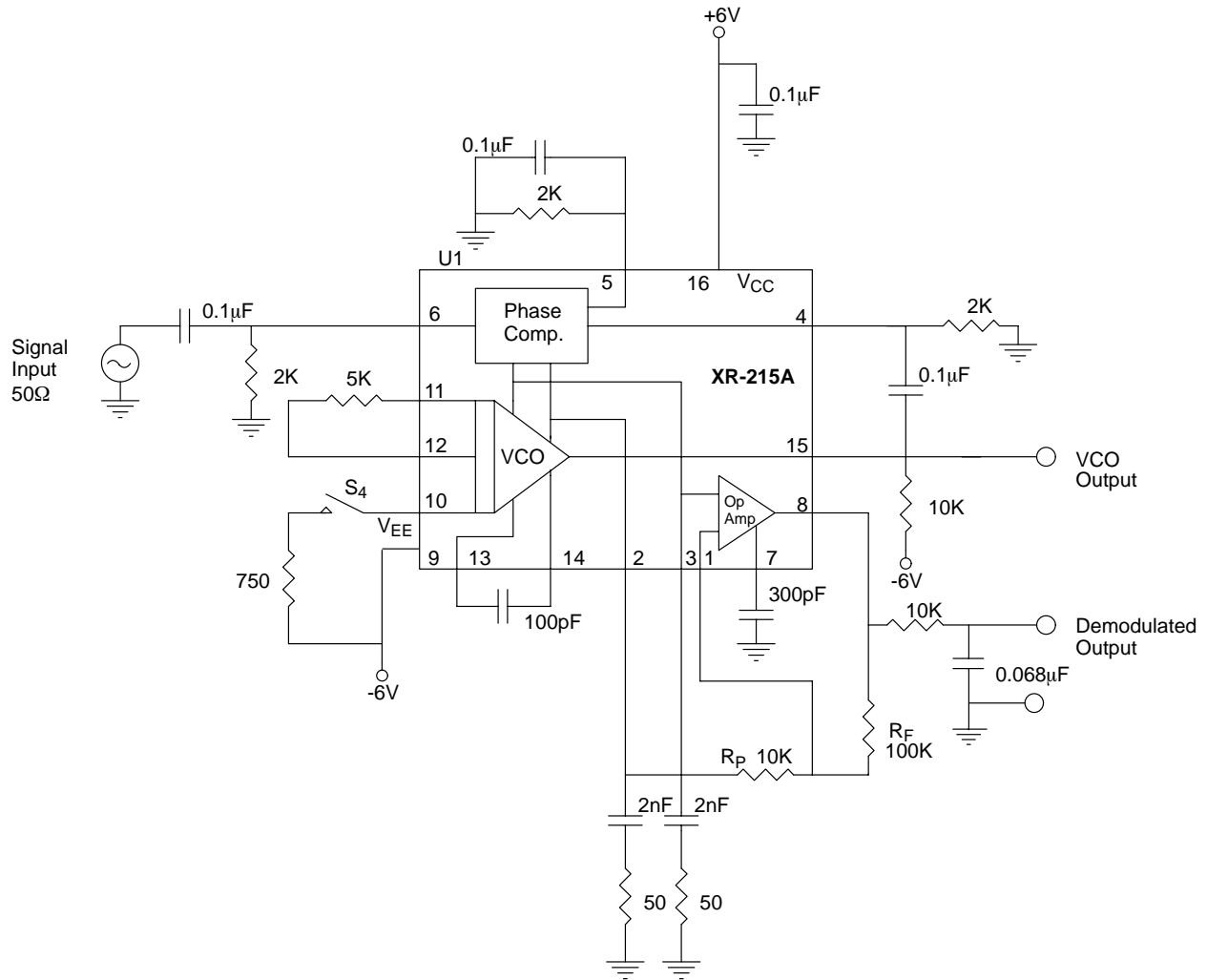

Figure 4. Test Circuit for Split-Supply Operation

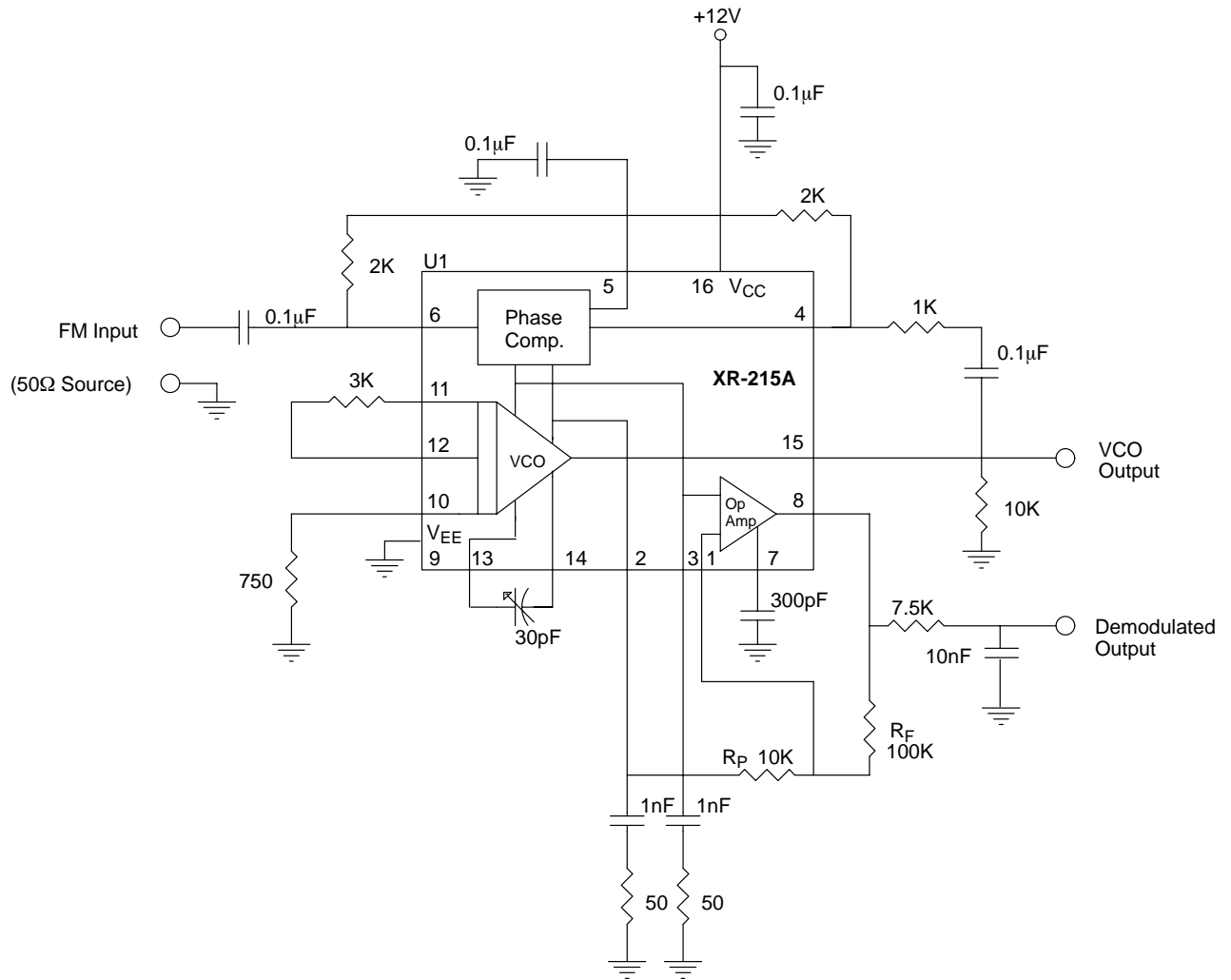

Figure 5. Test Circuit for FM Demodulation

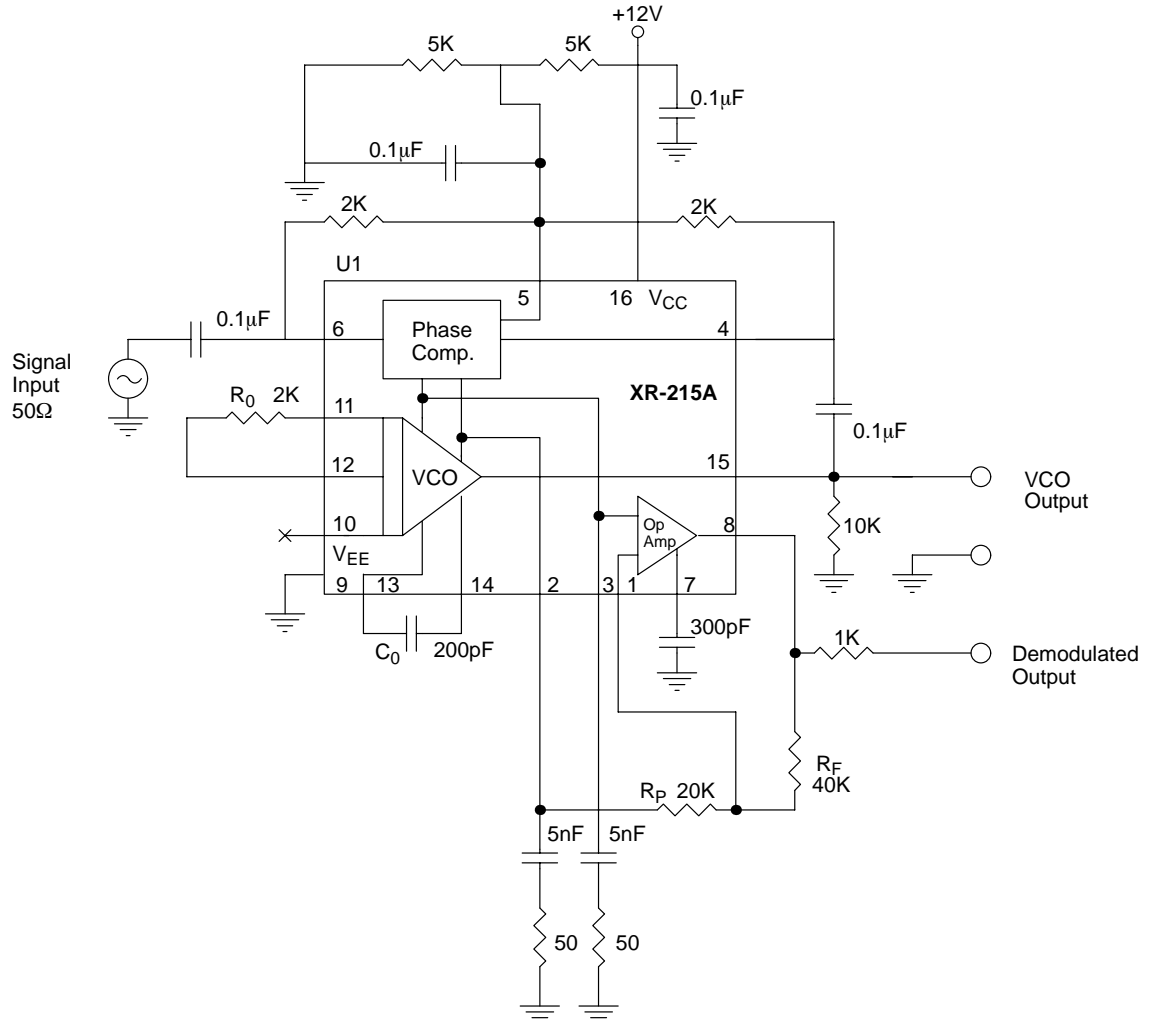

Figure 6. Test Circuit For Tracking Filter

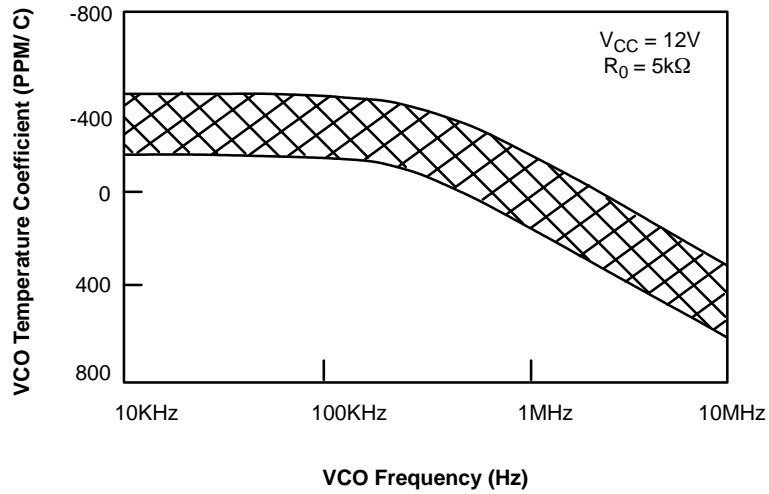

Figure 7. Typical VCO Temperature Coefficient Range as a Function of Operating Frequency (Pin 10 open)

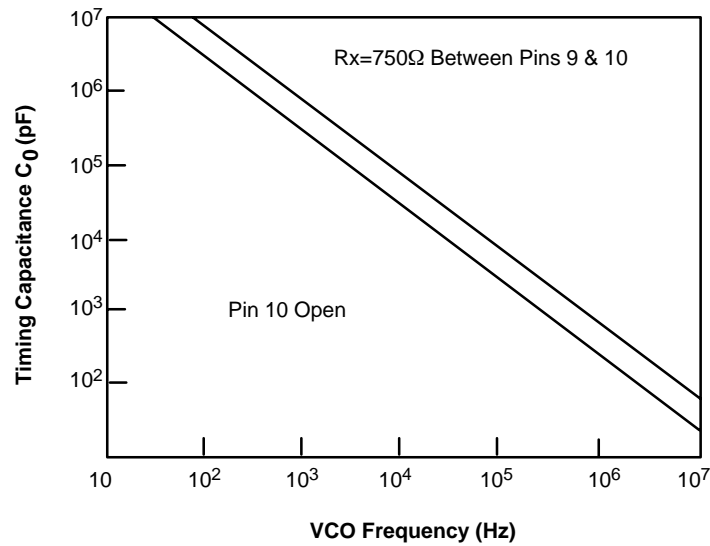

Figure 8. VCO Free Running Frequency vs. Timing Capacitor

VCO Timing Capacitor (Pins 13 and 14)

The VCO free-running frequency, f_o , is inversely proportional to timing capacitor C_0 connected between pins 13 and 14. (See Figure 8.)

VCO Output (Pin 15)

The VCO produces approximately a 2.5Vp-p output signal at this pin. The DC output level is approximately 2 volts below V_{CC} . This pin should be connected to pin 9 through a 10k Ω resistor to increase the output current drive capability. For high voltage operation ($V_{CC} > 20V$), a 20k Ω resistor is recommended. It is also advisable to connect a 500 Ω resistor in series with this output for short circuit protection.

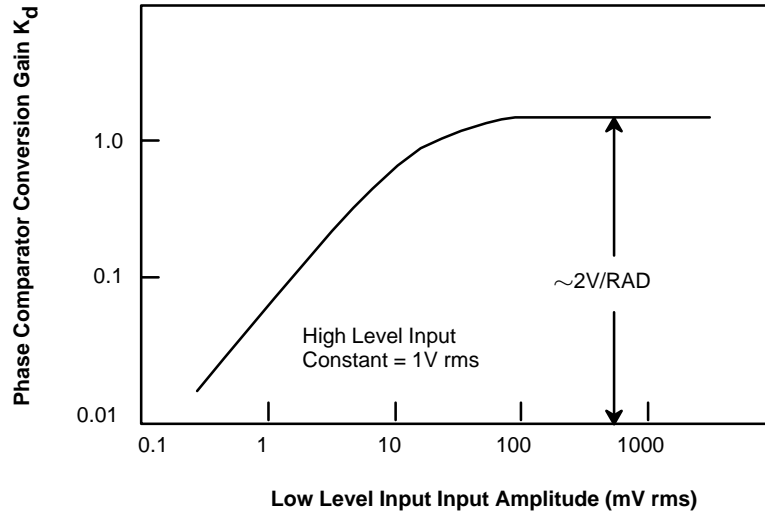

Figure 9. Phase Comparator Conversion Gain, K_d , versus Input Amplitude

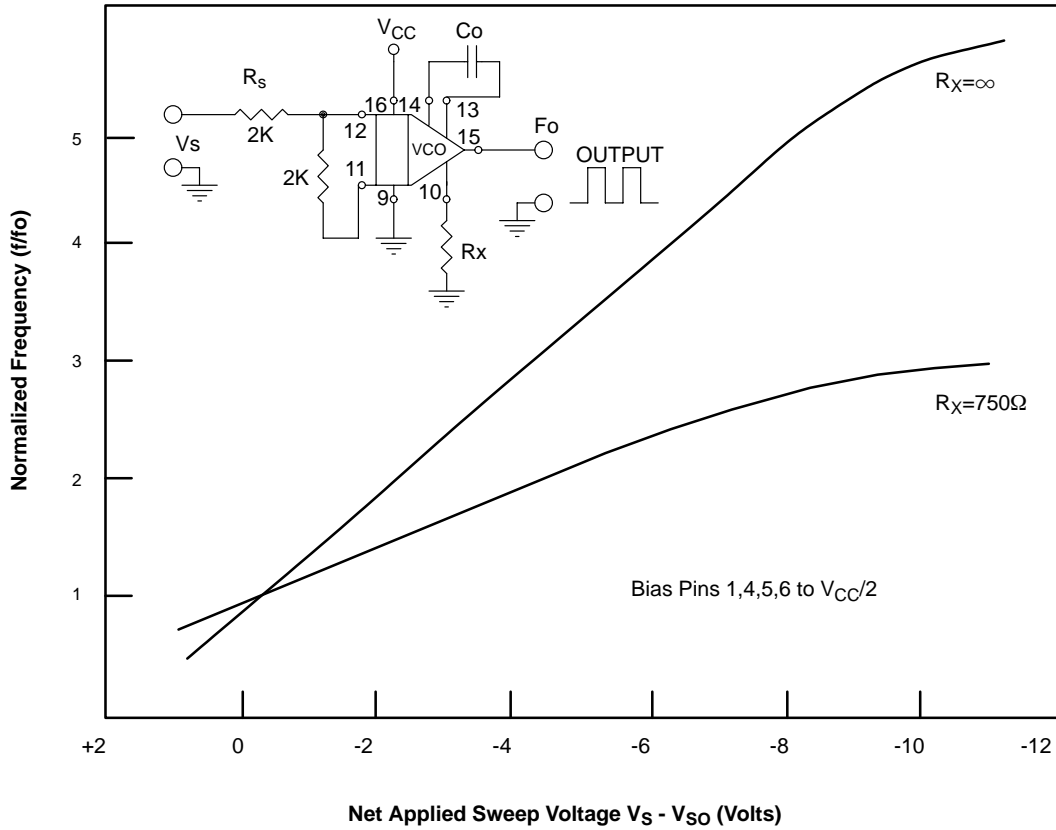

Figure 10. Typical Frequency Sweep Characteristics as a Function of Applied Sweep Voltage

Note:

$V_{SO} \approx V_{CC} - 5V = \text{Open Circuit Voltage at pin 12}$

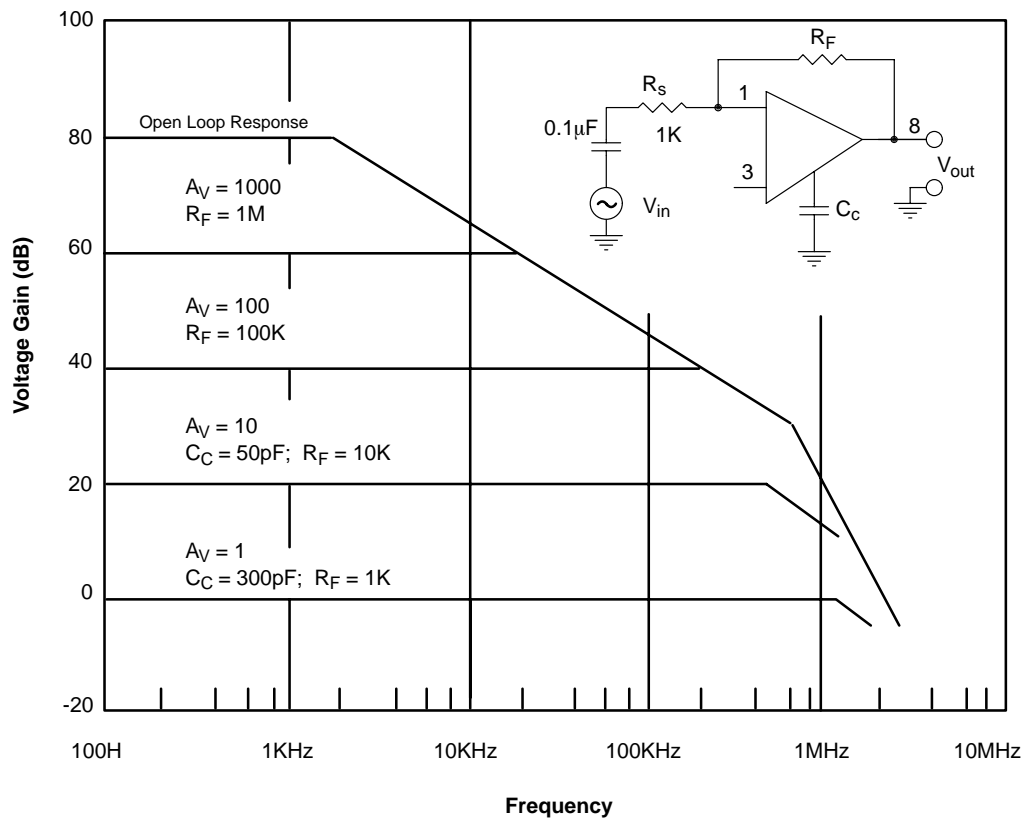

Figure 11. XR-215A Op Amp Frequency Response

VCO Sweep Input (Pin 12)

The VCO Frequency can be swept over a broad range by applying an analog sweep voltage, V_S , to pin 12 (see *Figure 10*.) The impedance looking into the sweep input is approximately 50Ω . Therefore, for sweep applications, a current limiting resistor, R_S , should be connected in series with this terminal. Typical sweep characteristics of the circuit are shown in *Figure 10*. The VCO temperature dependence is minimum when the sweep input is not used.

CAUTION: For safe operation of the circuit, the maximum current, I_S , drawn from the sweep terminal should be limited to 5mA or less under all operating conditions.

ON-OFF KEYING: With pin 10 open circuited, the VCO can be keyed off by applying a positive voltage pulse to the sweep input terminal. With $R_S = 2k\Omega$, oscillations will stop if the applied potential at pin 12 is raised 3 volts above its open-circuit value. When sweep, sync, or on-off keying functions are not used, R_S is not necessary.

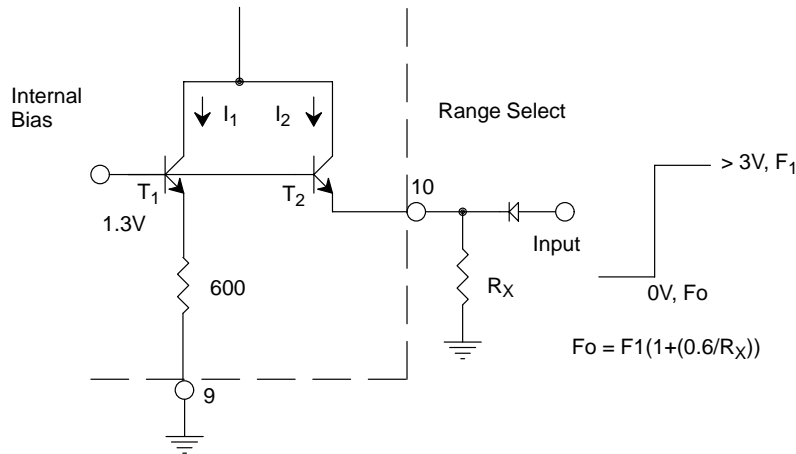

Figure 12. Explanation of VCO Range-Select Controls

Range-Select (Pin 10)

The frequency range of the XR-215A can be extended by connecting an external resistor, R_X , between pins 9 and 10. With reference to *Figure 12*, the operation of the range-select terminal can be explained as follows: The VCO frequency is proportional to the sum of currents I_1 and I_2 through transistors T_1 and T_2 on the monolithic chip. These transistors are biased from a fixed internal reference. The current I_1 is set internally, whereas I_2 is set by the external resistor R_X . Thus, at any C_0 setting, the VCO frequency can be expressed as:

$$f_0 = f_1 \left(1 + \frac{0.6}{R_X} \right)$$

where f_1 is the frequency with pin 10 open circuited and R_X is in $k\Omega$. External resistor R_X ($\approx 750\Omega$) is recommended for operation at frequencies in excess of 5MHz.

The range select terminal can also be used for fine tuning the VCO frequency, by varying the value of R_X . Similarly, the VCO frequency can be changed in discrete steps by switching in different values of R_X between pins 9 and 10.

Digital Programming

Using the range select control, the VCO frequency can be stepped in a binary manner, by applying a logic signal to pin 10, as shown in *Figure 12*. For high level logic inputs, transistor T_2 is turned off, and R_X is effectively switched out of the circuit. Using the digital programming capability, the XR-215A can be time-multiplexed between two separate input frequencies, as shown in *Figure 19* and *Figure 20*.

Amplifier Input (Pin 1)

This pin provides the inverting input for the operational amplifier section. Normally it is connected to pin 2 through a 10 $k\Omega$ external resistor (see *Figure 3* or *Figure 4*.)

Amplifier Output (Pin 8)

This pin is used as the output terminal for FM or FSK demodulation. The amplifier gain is determined by the external feedback resistor, R_F , connected between pins 1 and 8. Frequency response characteristics of the amplifier section are shown in *Figure 11*.

Amplifier Compensation (Pin 7)

The operational amplifier can be compensated for unity gain by a single 300pF capacitor from pin 7 to ground. (See *Figure 11*.)

BASIC PHASE-LOCKED LOOP OPERATION

Principle of Operation

The phase-locked loop (PLL) is a unique and versatile circuit technique which provides frequency selective tuning and filtering without the need for coils or inductors. As shown in *Figure 13*, the PLL is a feedback system comprised of three basic functional blocks: phase comparator, low-pass filter and voltage-controlled oscillator (VCO). The basic principle of operation of a PLL can be briefly explained as follows: with no input signal applied to the system, the error voltage V_d , is equal to zero. The VCO operates at a set frequency, f_o , which is known as the “free-running” frequency. If an input signal is applied to the system, the phase comparator compares the phase and frequency of the input signal with the VCO frequency and generates an error voltage, $V_e(t)$, that is related to the phase and frequency difference between the two signals. This error voltage is then filtered and

applied to the control terminal of the VCO. If the input frequency, f_s , is sufficiently close to f_o , the feedback nature of the PLL causes the VCO to synchronize or “lock” with the incoming signal. Once in lock, the VCO frequency is identical to the input signal, except for a finite phase difference.

A Linearized Model for PLL

When the PLL is in lock, it can be approximated by the linear feedback system shown in *Figure 14*. θ_s and θ_o are the respective phase angles associated with the input signal and the VCO output, $F(s)$ is the low-pass filter response in frequency domain, and K_d and K_o are the conversion gains associated with the phase comparator and VCO sections of the PLL.

DEFINITION OF XR-215A PARAMETERS USED FOR PLL APPLICATIONS DESIGN

VCO Free-Running Frequency, f_o

The VCO frequency with no input signal is determined by selection of C_o across pins 13 and 14 and can be increased by connecting an external resistor R_X between pins 9 and 10. It can be approximated as:

$$f_o \approx \frac{220}{C_o} \left(1 + \frac{0.6}{R_X} \right)$$

where C_o is in μF and R_X is in $\text{k}\Omega$. (See *Figure 8*.)

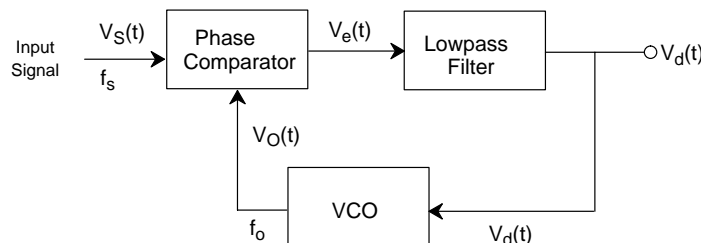

Figure 13. Block Diagram of a Phase-Locked Loop

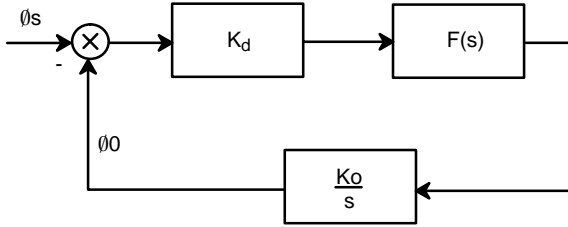

Figure 14. Linearized Model of a PLL as a Negative Feedback System

Phase Comparator Gain K_d

The output voltage from the phase comparator per radian of phase difference at the phase comparator inputs (pins 4 and 6). The units are volts/radians. (See *Figure 9*.)

VCO Conversion Gain K_o

The VCO voltage-to-frequency conversion gain is determined by the choice of timing capacitor C_0 and gain control resistor, R_0 connected externally across pins 11 and 12. It can be expressed as:

$$K_o \approx \frac{700}{C_0 R_0} \text{ (radians/sec/volt)}$$

where C_0 is in μF and R_0 is in $\text{k}\Omega$. For most applications, recommended values for R_0 range from $1\text{k}\Omega$ to $10\text{k}\Omega$.

Lock Range ($\Delta\omega_L$)

The range of frequencies in the vicinity of f_o , over which the PLL can maintain lock with an input signal. It is also known as the “tracking” or “holding” range. If saturation or limiting does not occur, the lock range is equal to the loop gain, i.e. $\Delta\omega_L = K_T = K_d K_o$.

Capture Range ($\Delta\omega_C$)

The band of frequencies in the vicinity of f_o where the PLL can establish or acquire lock with an input signal. It is also known as the “acquisition” range. It is always smaller than the lock range and is related to the low-pass filter bandwidth. It can be approximated by a parametric equation of the form:

$$\Delta\omega_C \approx \Delta\omega_L |F(j\Delta\omega_C)|$$

where $|F(j\Delta\omega_C)|$ is the low-pass filter magnitude response at $\omega = \Delta\omega_C$. For a simple lag filter, it can be expressed as:

$$\Delta\omega_C \approx \sqrt{\frac{\Delta\omega_L}{T_1}}$$

where T_1 is the filter time constant.

Amplifier Gain A_V

The voltage gain of the amplifier section is determined by feedback resistors R_F and R_p between pins (8,1) and (2,1) respectively. (See *Figure 3* and *Figure 4*.) It is given by:

$$A_V \approx \frac{-R_F}{R_1 + R_P}$$

where R_1 is the ($6\text{k}\Omega$) internal impedance at pin 2.

Low-Pass Filter

The low-pass filter section is formed by connecting an external capacitor or RC network across terminals 2 and 3. The low-pass filter components can be connected either between pins 2 and 3 or, from each pin to ground. Typical filter configurations and corresponding filter

transfer functions are shown in *Figure 15* where R_1 ($6k\Omega$) is the internal impedance at pins 2 and 3. It should be noted that the rejection of the low pass filter decreases above 2MHz when the capacitor is tied from pin 2 to 3.

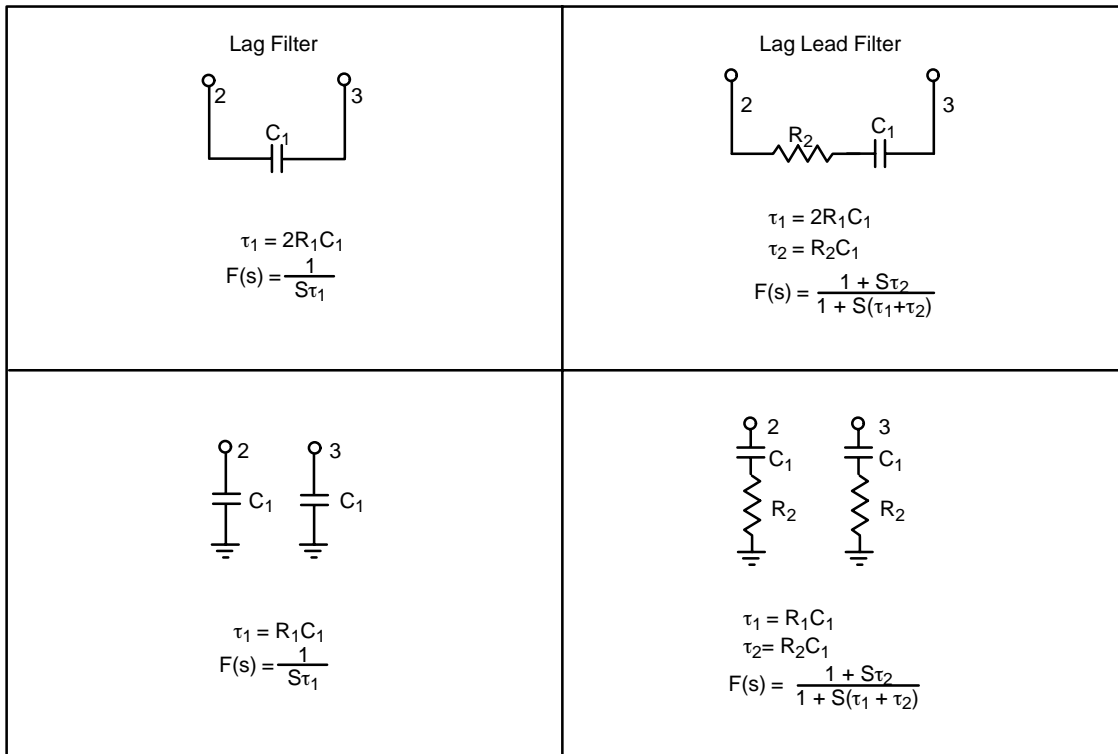

Figure 15.

Note:

$R_1 = 6k\Omega$ internal resistor.

The natural frequency ω_n can be calculated from the VCO conversion gain K_0 , the phase comparator conversion gain K_d , and the low pass filter time constants τ_1 and τ_2 as follows:

$$\zeta = \frac{\omega_n}{2} \left(\tau_2 + \frac{1}{K_0 \cdot K_d} \right)$$

Then the damping factor ζ can be calculated using:

$$\omega_n = \sqrt{\frac{K_0 \cdot K_d}{\tau_1 + \tau_2}}$$

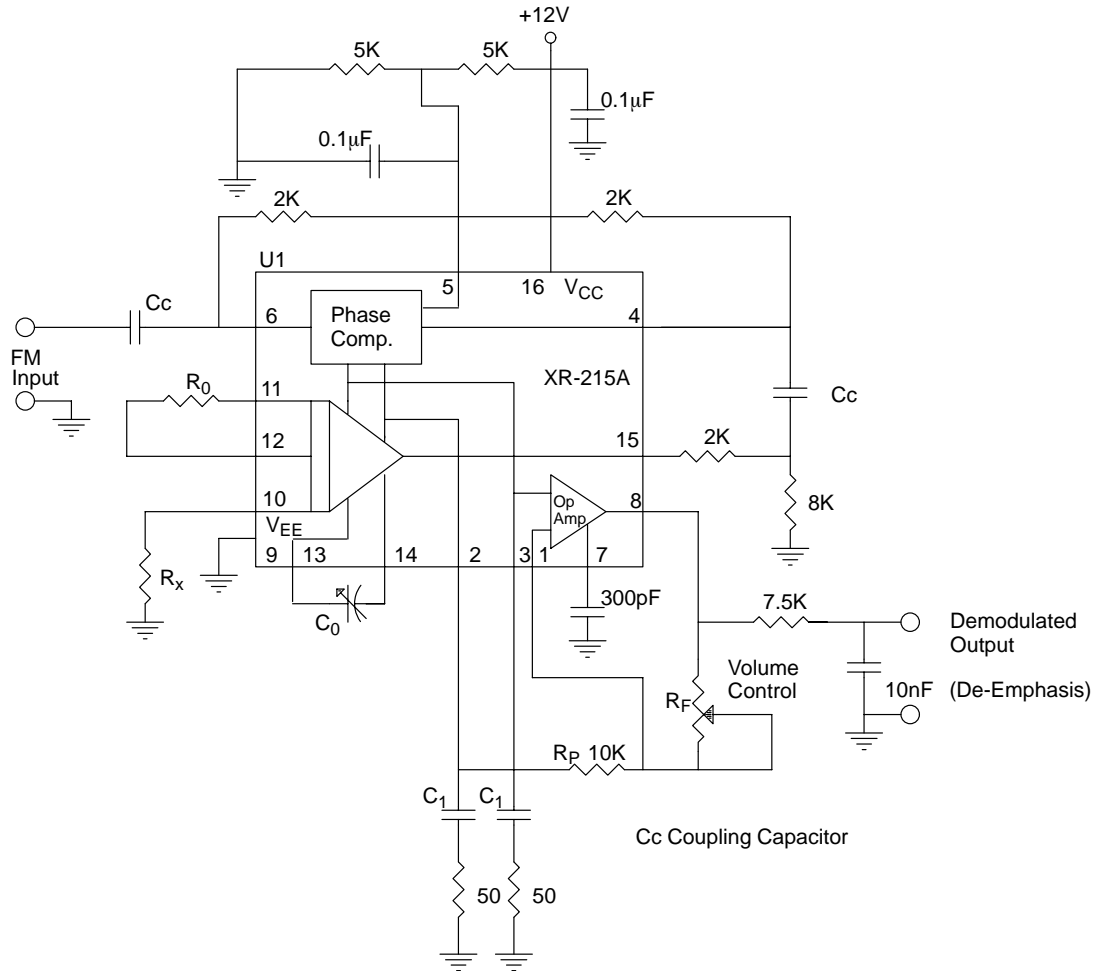

Figure 16. Circuit Connection for FM Demodulation

APPLICATIONS INFORMATION

FM Demodulation

Figure 16 shows the external circuit connections to the XR-215A for frequency-selective FM demodulation. The choice of C₀ is determined by the FM carrier frequency (see Figure 8.) The low-pass filter capacitor C₁ is determined by the selectivity requirements. For carrier frequencies of 1 to 10MHz, C₁ is in the range of 10·C₀ to 30·C₀. The feedback resistor R_F can be used as a “volume-control” adjustment to set the amplitude of the demodulated output. The demodulated output amplitude is proportional to the FM deviation and to resistors R₀ and R_F for ±1% FM deviation it can be approximated as:

$$V_{OUT} \approx R_0 R_F \left(1 + \frac{0.6}{R_X} \right) mV, \text{ rms}$$

where all resistors are in kΩ and R_X is the range extension resistor connected across pins 9 and 10. For circuit operation below 5MHz, R_X can be omitted. For operation above 5MHz, R_X ≈ 750Ω is recommended.

Typical output signal/noise ratio and harmonic distortion are shown in Figure 17 and Figure 18 as a function of FM deviation, for the component values shown in Figure 5.

Multi-Channel Demodulation

The AC digital programming capability of the XR-215A allows a single circuit be time-shared or multiplexed between two information channels, and thereby selectively demodulate two separate carrier frequencies. *Figure 19* shows a practical circuit configuration for time-multiplexing the XR-215A between two FM channels, at 1MHz and 1.1MHz respectively. The channel-select logic signal is applied to pin 10, as shown in *Figure 19* with both input channels simultaneously present at the PLL input (pin 4). *Figure 20* shows the demodulated output as a function of the channel-select pulse where the two inputs have sinusoidal and triangular FM modulation respectively.

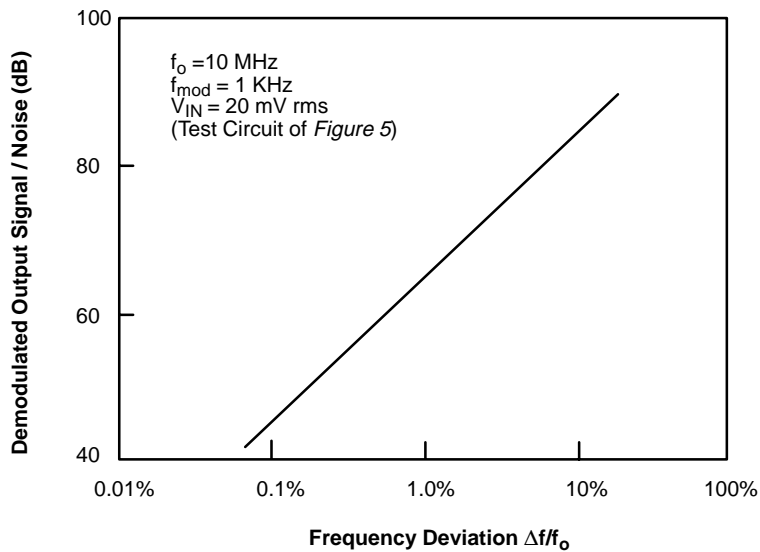

Figure 17. Output Signal/Noise Ratio as a Function of FM Deviation

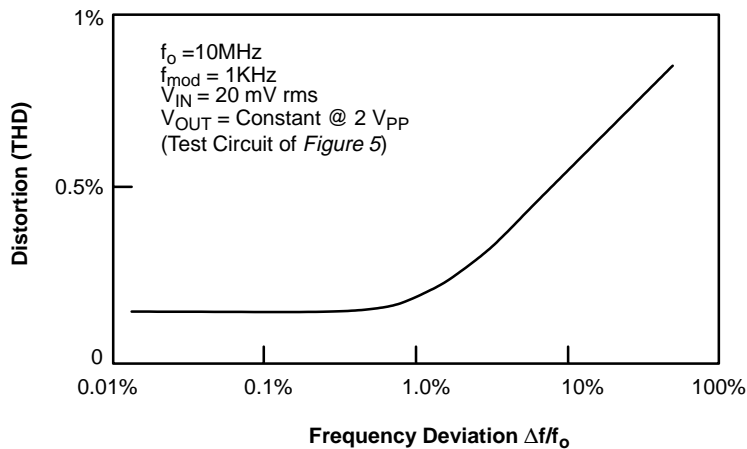

Figure 18. Output Distortion as a Function of FM Deviation

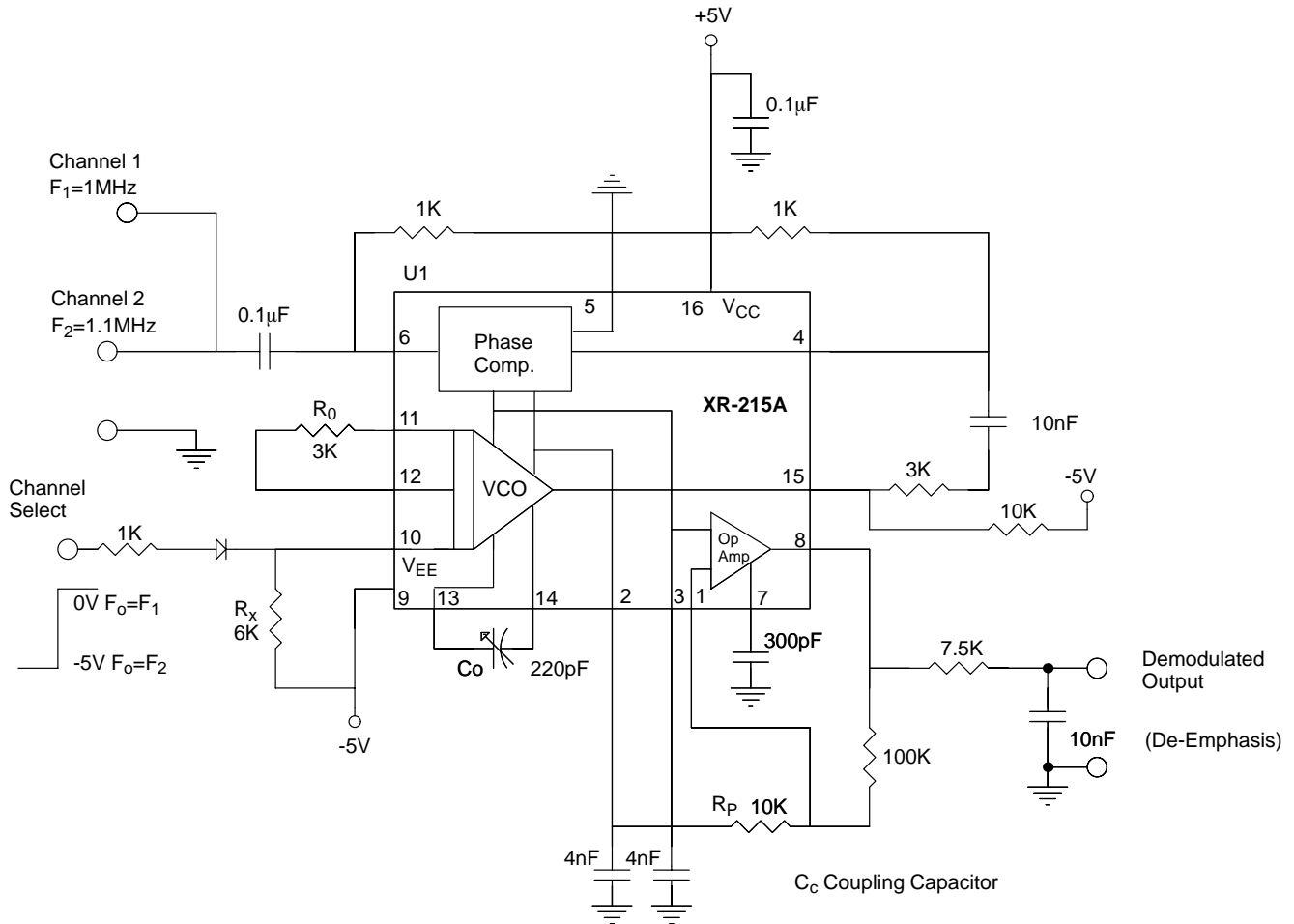

Figure 19. Time-Multiplexing XR-215A Between Two Simultaneous FM Channels

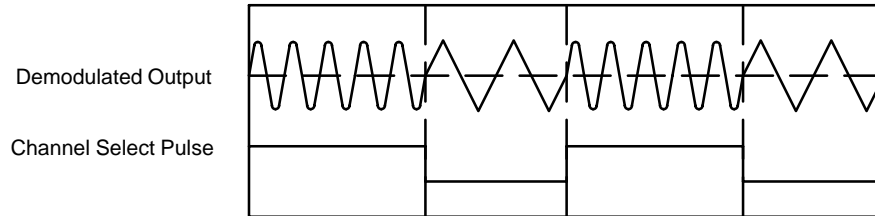

Figure 20. Demodulated Output Waveforms for Time-Multiplexed Operation

FSK Demodulation

Figure 21 contains a typical circuit connection for FSK demodulation. When the input frequency is shifted, corresponding to a data bit, the DC voltage at the phase comparator outputs (pins 2 and 3) also reverses polarity. The operational amplifier section is connected as a comparator, and converts the DC level shift to a binary output pulse. One of the phase comparator outputs (pin 3) is AC grounded and serves as the bias reference for the operational amplifier section. Capacitor C_1 serves as the PLL loop filter, and C_2 and C_3 as post-detection filters. Range select resistor, R_X , can be used as a fine-tune adjustment to set the VCO frequency.

Typical component values for 300 baud and 1200 baud operation are listed below:

Operating Conditions	Typical Component Values
300 Baud Low Band: $f_1 = 1070\text{Hz}$ $f_2 = 1270\text{Hz}$	$R_0 = 5\text{k}\Omega$, $C_0 = 0.17\mu\text{F}$ $C_1 = C_2 = 0.047\mu\text{F}$, $C_3 = 0.033\mu\text{F}$
High Band: $f_1 = 2025\text{Hz}$ $f_2 = 2225\text{Hz}$	$R_0 = 8\text{k}\Omega$, $C_0 = 0.1\mu\text{F}$ $C_1 = C_2 = C_3 = 0.033\mu\text{F}$
1200 Baud $f_1 = 1200\text{Hz}$ $f_2 = 2200\text{Hz}$	$R_0 = 2\text{k}\Omega$, $C_0 = 0.12\mu\text{F}$ $C_1 = C_3 = 0.003\mu\text{F}$ $C_2 = 0.01\mu\text{F}$

Table 1. Typical Component Values for Modems

Note:

For 300 Baud operation the circuit can be time-multiplexed between high and low bands by switching the external resistor R_X in and out of the circuit with a control signal, as shown in Figure 12.

FSK Generation

The digital programming capability of the XR-215A can be used for FSK generation. A typical circuit connection for this application is shown in Figure 22. The VCO frequency can be shifted between the mark (f_2) and space (f_1) frequencies by applying a logic pulse to pin 10. The circuit can provide two separate FSK outputs: a low level (2.5 Vp-p) output at pin 15 or a high amplitude (10 Vp-p) output at pin 8. The output at each of these terminals is a symmetrical squarewave with a typical second harmonic content of less than 0.3%.

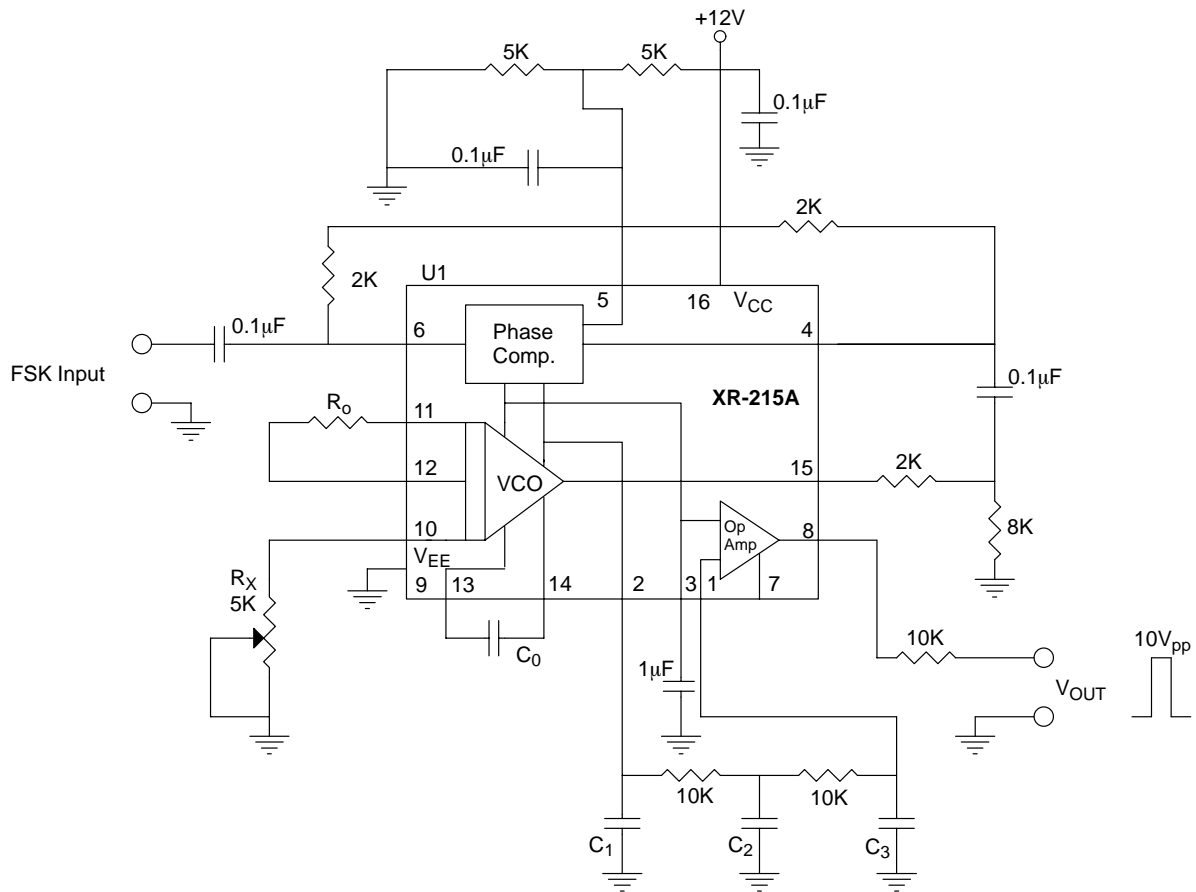

Figure 21. Circuit Connection for FSK Demodulation

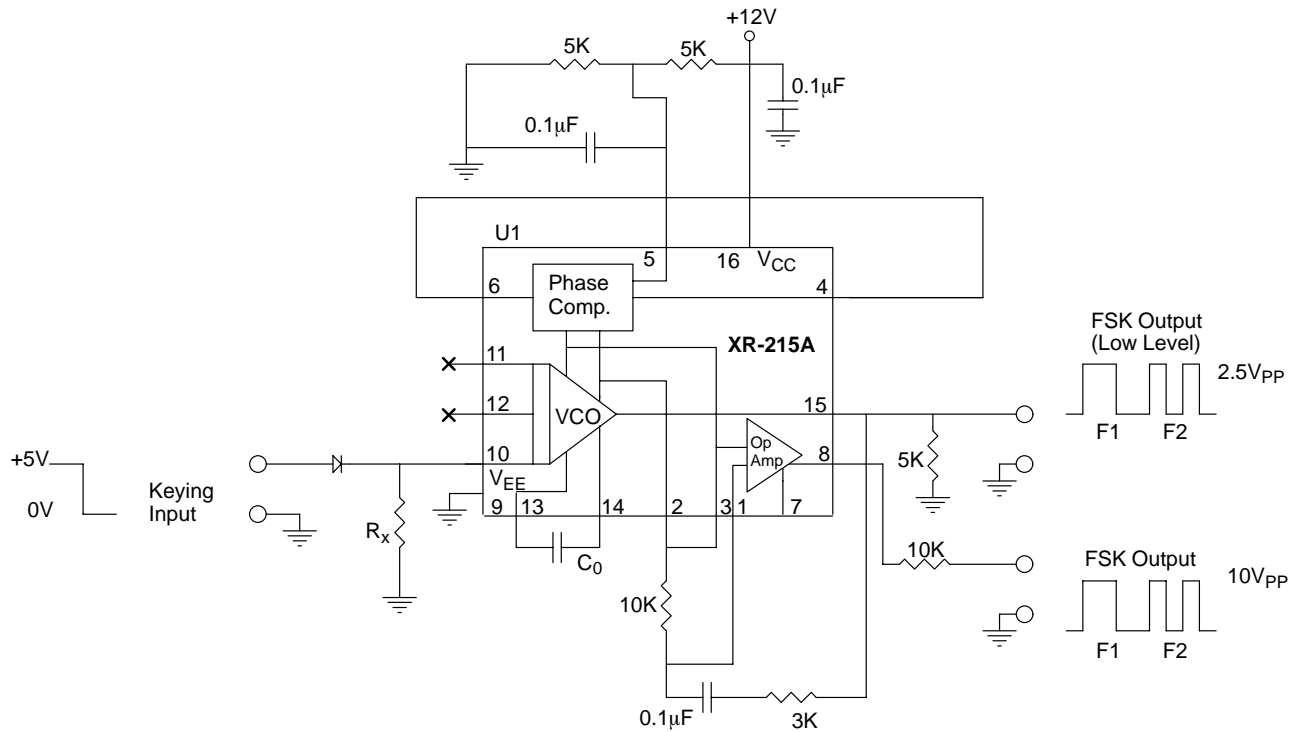

Figure 22. Circuit Connection For FSK Generation

Frequency Synthesis

In frequency synthesis applications, a programmable counter or divide-by-N circuit is connected between the VCO output (pin 15) and one of the phase detector inputs (pins 4 or 6), as shown in *Figure 23*. The principle of operation of the circuit can be briefly explained as follows: The counter divides down the oscillator frequency by the programmable divider modulus, N. Thus, when the entire system is phase-locked to an input signal at frequency, f_s , the oscillator output at pin 15 is at a frequency (Nf_s), where N is the divider modulus. By proper choice of the divider modulus, a large number of discrete frequencies can be synthesized from a given reference frequency. The low-pass filter capacitor C_1 is normally chosen to provide a cut-off frequency equal to 0.1% to 2% of the signal frequency, f_s .

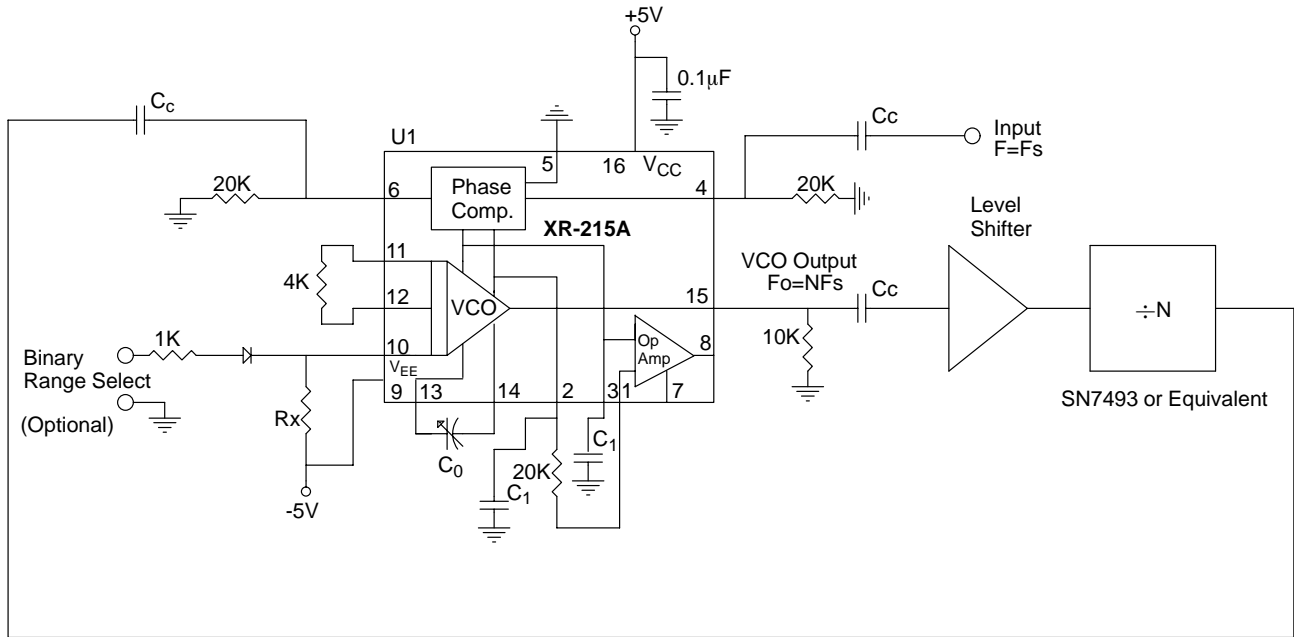

Figure 23. Circuit Connection For Frequency Synthesis

The circuit was designed to operate with commercially available monolithic programmable counter circuits using TTL logic, such as MC4016, SN5493 or equivalent. The digital or analog tuning characteristics of the VCO can be used to extend the available range of frequencies of the system, for a given setting of the timing capacitor C_0 .

Typical input and output waveforms for $N = 16$ operation with $f_s = 100\text{kHz}$ and $f_o = 1.6\text{MHz}$ are shown in *Figure 24*.

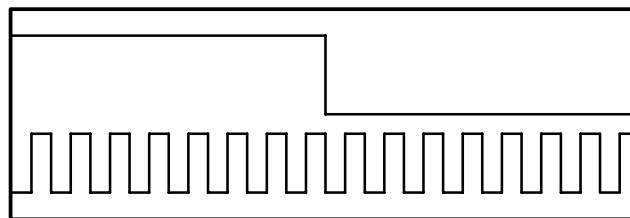

Figure 24. Typical Input/Output Waveforms for $N=16$
Top: Input (100kHz)
Bottom: VCO Output (1.6MHz)

Tracking Filter/Discriminator

The wide tracking range of the XR-215A allows the system to track an input signal over a 3:1 frequency range, centered about the VCO free running frequency. The tracking range is maximum when the binary range-select (pin 10) is open circuited. The circuit connections for this application are shown in *Figure 25*. Typical tracking range for a given input signal amplitude is shown

in *Figure 26*. Recommended values of external components are:

$1k\Omega < R_0 < 4k\Omega$ and $30 C_0 < C_1 < 300 C_0$ where the timing capacitor C_0 is determined by the center frequency requirements (see *Figure 8*.)

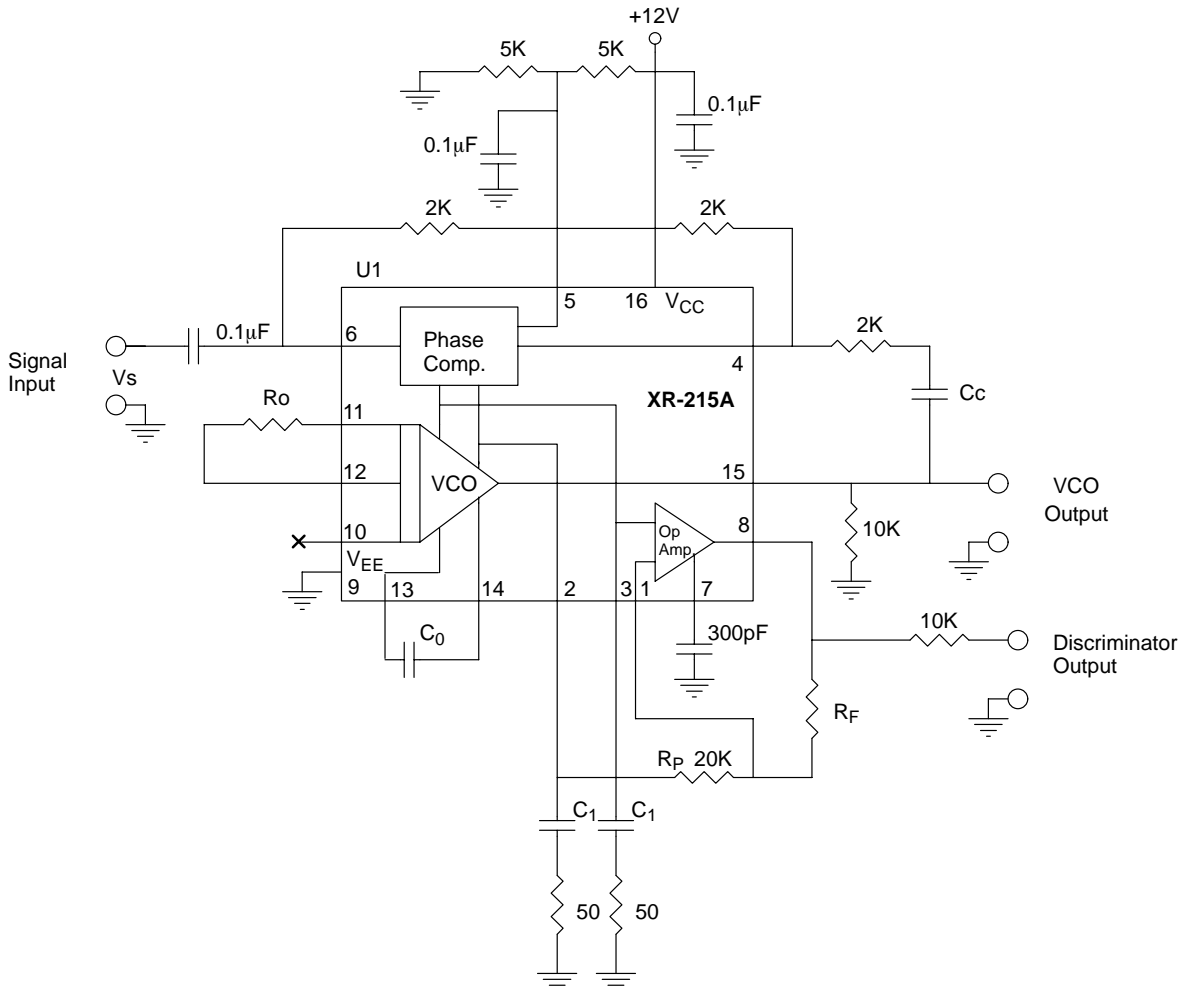

Figure 25. Circuit Connection For Tracking Filter Applications

The phase-comparator output voltage is a linear measure of the VCO frequency deviation from its free-running value. The amplifier section, therefore, can be used to provide a filtered and amplified version of the loop error voltage. In this case, the DC output level at pin 15 can be adjusted to be directly proportional to the difference between the VCO free-running frequency, f_0 , and the input signal, f_s . The entire system can operate as a “linear discriminator” or analog “frequency-meter” over a 3:1 change of input frequency. The discriminator gain can be adjusted by proper choice of R_0 or R_F , for the test circuit of *Figure 25*, the discriminator output is approximately $(0.7 R_0 R_F)$ mV per % of frequency deviation where R_0 and R_F are in $k\Omega$. Output non-linearity is typically less than 1% for frequency deviations up to $\pm 15\%$. *Figure 28* shows the normalized output characteristics as a function of input frequency, with $R_0 = 2k\Omega$ and $R_F = 36k\Omega$.

Crystal-Controlled PLL

The XR-215A can be operated as a crystal-controlled phase-locked loop by replacing the timing capacitor with a crystal. A circuit connection for this application is shown in *Figure 28*. Normally a small tuning capacitor ($\approx 30pF$) is required in series with the crystal to set the crystal frequency. For this application the crystal should be operated in its fundamental mode. Typical pull-in range of the circuits is $\pm 1kHz$ at 10MHz. There is some distortion on the demodulated output.

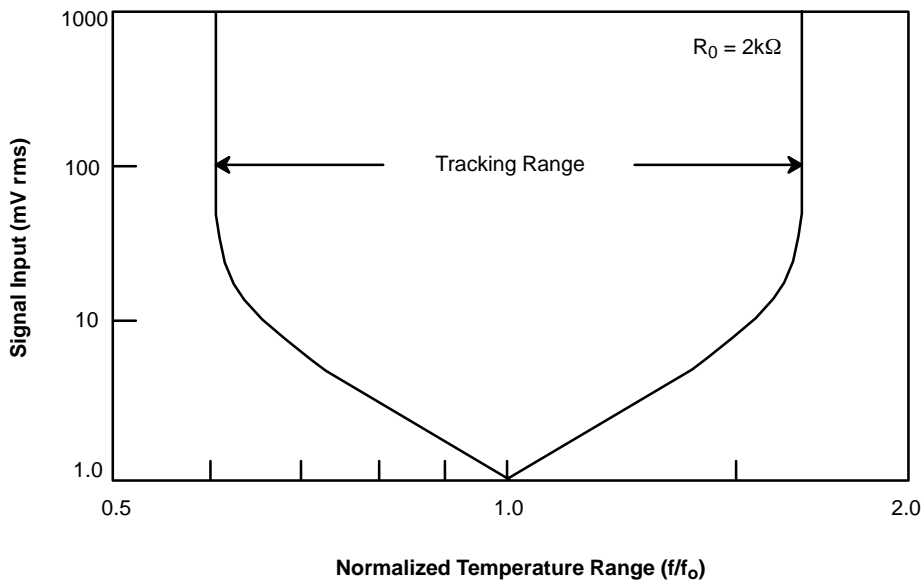
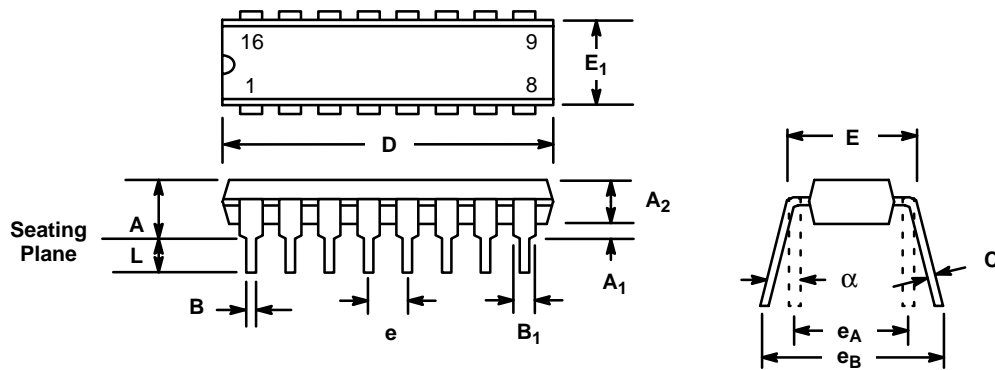

Figure 26. Tracking Range vs. Input Amplitude (Pin 10 Open Circuited)

**16 LEAD PLASTIC DUAL-IN-LINE
(300 MIL PDIP)**

Rev. 1.00



SYMBOL	INCHES		MILLIMETERS	
	MIN	MAX	MIN	MAX
A	0.145	0.210	3.68	5.33
A ₁	0.015	0.070	0.38	1.78
A ₂	0.115	0.195	2.92	4.95
B	0.014	0.024	0.36	0.56
B ₁	0.030	0.070	0.76	1.78
C	0.008	0.014	0.20	0.38
D	0.745	0.840	18.92	21.34
E	0.300	0.325	7.62	8.26
E ₁	0.240	0.280	6.10	7.11
e	0.100 BSC		2.54 BSC	
e _A	0.300 BSC		7.62 BSC	
e _B	0.310	0.430	7.87	10.92
L	0.115	0.160	2.92	4.06
α	0°	15°	0°	15°

Note: The control dimension is the inch column

16 LEAD SMALL OUTLINE (300 MIL JEDEC SOIC)

Rev. 1.00

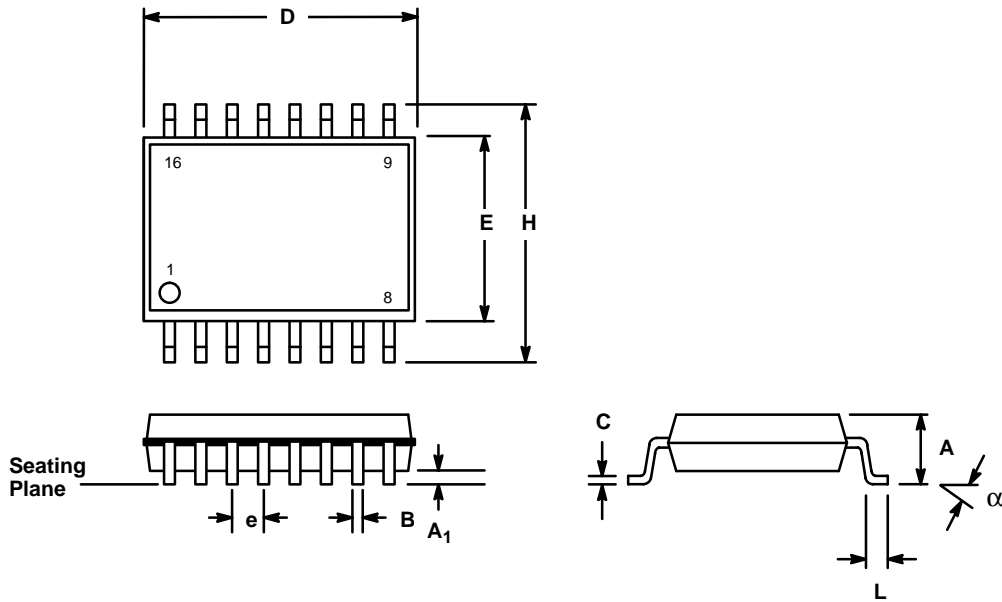

SYMBOL	INCHES		MILLIMETERS	
	MIN	MAX	MIN	MAX
A	0.093	0.104	2.35	2.65
A ₁	0.004	0.012	0.10	0.30
B	0.013	0.020	0.33	0.51
C	0.009	0.013	0.23	0.32
D	0.398	0.413	10.10	10.50
E	0.291	0.299	7.40	7.60
e	0.050 BSC		1.27 BSC	
H	0.394	0.419	10.00	10.65
L	0.016	0.050	0.40	1.27
α	0°	8°	0°	8°

Note: The control dimension is the millimeter column

Notes

NOTICE

EXAR Corporation reserves the right to make changes to the products contained in this publication in order to improve design, performance or reliability. EXAR Corporation assumes no responsibility for the use of any circuits described herein, conveys no license under any patent or other right, and makes no representation that the circuits are free of patent infringement. Charts and schedules contained here in are only for illustration purposes and may vary depending upon a user's specific application. While the information in this publication has been carefully checked; no responsibility, however, is assumed for inaccuracies.

EXAR Corporation does not recommend the use of any of its products in life support applications where the failure or malfunction of the product can reasonably be expected to cause failure of the life support system or to significantly affect its safety or effectiveness. Products are not authorized for use in such applications unless EXAR Corporation receives, in writing, assurances to its satisfaction that: (a) the risk of injury or damage has been minimized; (b) the user assumes all such risks; (c) potential liability of EXAR Corporation is adequately protected under the circumstances.

Copyright 1975 EXAR Corporation
Datasheet June 1997

Reproduction, in part or whole, without the prior written consent of EXAR Corporation is prohibited.