



XR-8038A

Precision Waveform Generator

June 1997-3

FEATURES

- Low Frequency Drift, 50ppm/°C, Typical
- Simultaneous Sine, Triangle, and Square Wave Outputs
- Low Sine Wave Distortion - THD \approx 1%
- High FM and Triangle Linearity
- Wide Frequency Range 0.001Hz to 200KHz
- Variable Duty Cycle, 2% to 98%
- Low Distortion Variation with Temperature

APPLICATIONS

- Precision Waveform Generation
- Sweep and FM Generation
- Tone Generation
- Instrumentation and Test Equipment Design
- Precision PLL Design

GENERAL DESCRIPTION

The XR-8038A is a precision waveform generator IC capable of producing sine, square, triangular, sawtooth, and pulse waveforms, with a minimum number of external components and adjustments. The XR-8038A allows the elimination of the external distortion adjusting resistor which greatly improves the temperature drift of distortion, as well as lowering external parts count. Its operating frequency can be selected over eight decades of frequency, from 0.001Hz to 200kHz, by the choice of external R-C components. The frequency of oscillation is highly stable over a wide range of temperature and supply

voltage changes. Both full frequency sweeping as well as smaller frequency variations (FM) can be accomplished with an external control voltage. Each of the three basic waveform outputs, (i.e., sine, triangle and square) are simultaneously available from independent output terminals.

The XR-8038A monolithic waveform generator uses advanced processing technology and Schottky-barrier diodes to enhance its frequency performance.

ORDERING INFORMATION

Part No.	Package	Operating Temperature Range
XR-8038ACP	14 Lead 300 mil PDIP	0°C to 70°C



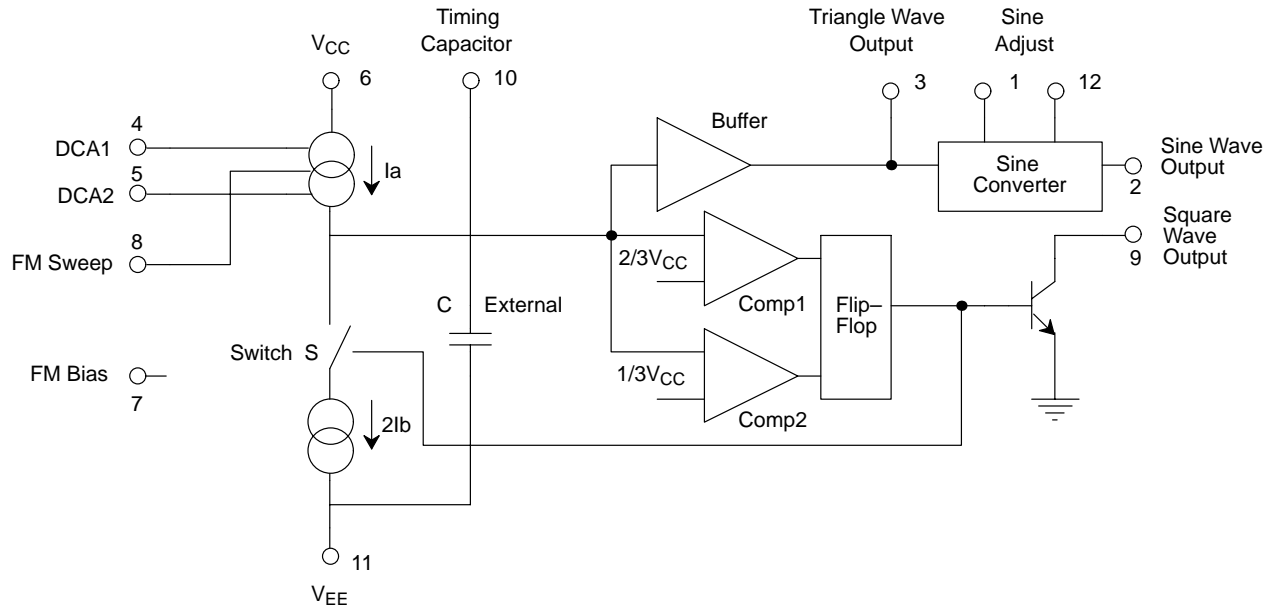
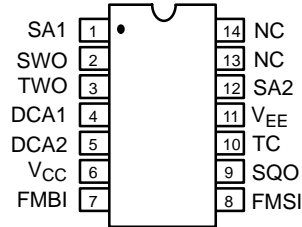

Figure 1. XR-8038A Block Diagram

PIN CONFIGURATION



14 Lead PDIP (0.300")

PIN DESCRIPTION

Pin #	Symbol	Type	Description
1	SA1	I	Wave Form Adjust Input 1.
2	SWO	O	Sine Wave Output.
3	TWO	O	Triangle Wave Output.
4	DCA1	I	Duty Cycle Adjustment Input.
5	DCA2	I	Duty Cycle Adjustment Input.
6	V _{CC}		Positive Power Supply.
7	FMBI	I	Frequency Modulation Input.
8	FMSI	I	Frequency Sweep Input.
9	SQO	O	Square Wave Output.
10	TC	I	Timing Capacitor Input.
11	V _{EE}		Negative Power Supply.
12	SA2	I	Wave Form Adjust Input 2.
13	NC		No Connect.
14	NC		No Connect.

DC ELECTRICAL CHARACTERISTICS

Test Conditions: $V_S = \pm 5V$ to $\pm 15V$, $T_A = 25^\circ C$, $R_L = 1M\Omega$, $R_A = R_B = 10k\Omega$, $C_1 = 3300pF$, S_1 closed, unless otherwise specified. (See Figure 2.)

Parameter	Min.	Typ.	Max.	Unit	Conditions
General Characteristics					
Supply Voltage, V_S					
Single Supply	10		30	V	
Dual Supplies	± 5		± 15	V	
Supply Current		12	20	mA	$V_S = \pm 10V^1$
Frequency Characteristics (Measured at Pin 9)					
Range of Adjustment					
Max. Operating Frequency	200			kHz	$R_A = R_B = 1.5k\Omega$, $C_1 = 680pF$; $R_L = 10K$
Lowest Practical Frequency		0.001		Hz	$R_A = R_B = 1M\Omega$, $C_1 = 500\mu F$ (Low Leakage Capacitor)
Max. Sweep Frequency of FM Input		100		kHz	
FM Sweep Range		1000:1			S_1 Open ^{2,3}
FM Linearity 10:1 Ratio		0.2		%	S_1 Open ³
Range of Timing Resistors	0.5		1000	K Ω	Values of R_A and R_B
Temperature Stability		50		PPM/ $^\circ C$	$T_A = 0^\circ C$ to $70^\circ C$
Power Supply Stability		0.05		%/V	$10V \leq V_S \leq 30V$ or $\pm 5V \leq V_S \leq 15V$
Output Characteristics					
Square-Wave					Measured at Pin 9
Amplitude (Peak-to-Peak)	0.9	0.98		$\times V_{SPLY}$	$R_L = 100k\Omega$
Saturation Voltage		0.2	0.5	V	$I_{SINK} = 2mA$
Rise Time		100		ns	$R_L = 4.7k\Omega$
Fall Time		40		ns	$R_L = 4.7k\Omega$
Duty Cycle Adjustment	2		98	%	
Triangle/Sawtooth/Ramp					Measured at Pin 3
Amplitude (Peak-to-Peak)	0.3	0.33		$\times V_{SPLY}$	$R_L = 100k\Omega$
Linearity		0.1		%	

Notes

¹ Currents through R_A and R_B not included.

² $V_{SUPPLY} = 20V$.

³ Apply sweep voltage at Pin 8.

$$V_{CC} - (1/3 V_{SUPPLY} - 2) \leq V_{PIN 8} \leq V_{CC}$$

$V_{SUPPLY} =$ Total Supply Voltage across the IC

Specifications are subject to change without notice

DC ELECTRICAL CHARACTERISTICS (CONT'D)

Test Conditions: $V_S = \pm 5V$ to $\pm 15V$, $T_A = 25^\circ C$, $R_L = 1M\Omega$, $R_A = R_B = 10k\Omega$, $C_1 = 3300pF$, S_1 closed, unless otherwise specified. (See Figure 2.)

Parameter	Min.	Typ.	Max.	Unit	Conditions
Output Characteristics (Cont'd)					
Output Impedance		200		Ω	$I_{OUT} = 5mA$
Sine-Wave Amplitude (Peak-to-Peak)	0.2	0.22		$\times V_{SPLY}$	$R_L = 100k\Omega$
Distortion		0.8	3	%	$R_L = 1M\Omega^{4,5}$
Unadjusted		0.5		%	$R_L = 1M\Omega^{4,5}$
Adjusted		0.3		%	

Notes

⁴ Triangle duty cycle set at 50%, use R_A and R_B .

⁵ As R_L is decreased distortion will increase, R_L min $\approx 50K\Omega$.

Bold face parameters are covered by production test and guaranteed over operating temperature range.

Specifications are subject to change without notice

ABSOLUTE MAXIMUM RATINGS

Power Supply 36V

Power Dissipation (package limitation)

 Plastic Package 625mW

 Derate Above $+25^\circ C$ 5mW/ $^\circ C$

Storage Temperature Range $-65^\circ C$ to $+150^\circ C$

SYSTEM DESCRIPTION

The XR-8038A precision waveform generator produces highly stable and sweepable square, triangle, and sine waves across eight frequency decades. The device time base employs resistors and a capacitor for frequency and duty cycle determination. The generator contains dual comparators, a flip-flop driving a switch, current sources, buffers, and a sine wave convertor. Three identical frequency outputs are simultaneously available. Supply voltage can range from 10V to 30V, or $\pm 5V$ to $\pm 15V$ with dual supplies.

Unadjusted sine wave distortion is typically less than 0.7% with the sine wave distortion adjust pin (Pin 1) open. Distortion levels may be improved by including a 100k Ω

potentiometer between the supplies, with the wiper connected to Pin 1.

Small frequency deviation (FM) is accomplished by applying modulation voltage to Pins 7 and 8; large frequency deviation (sweeping) is accomplished by applying voltage to Pin 8 only. Sweep range is typically 1000:1.

The square wave output is an open collector transistor; output amplitude swing closely approaches the supply voltage. Triangle output amplitude is typically 1/3 of the supply, and sine wave output reaches 0.22 of the supply voltage.

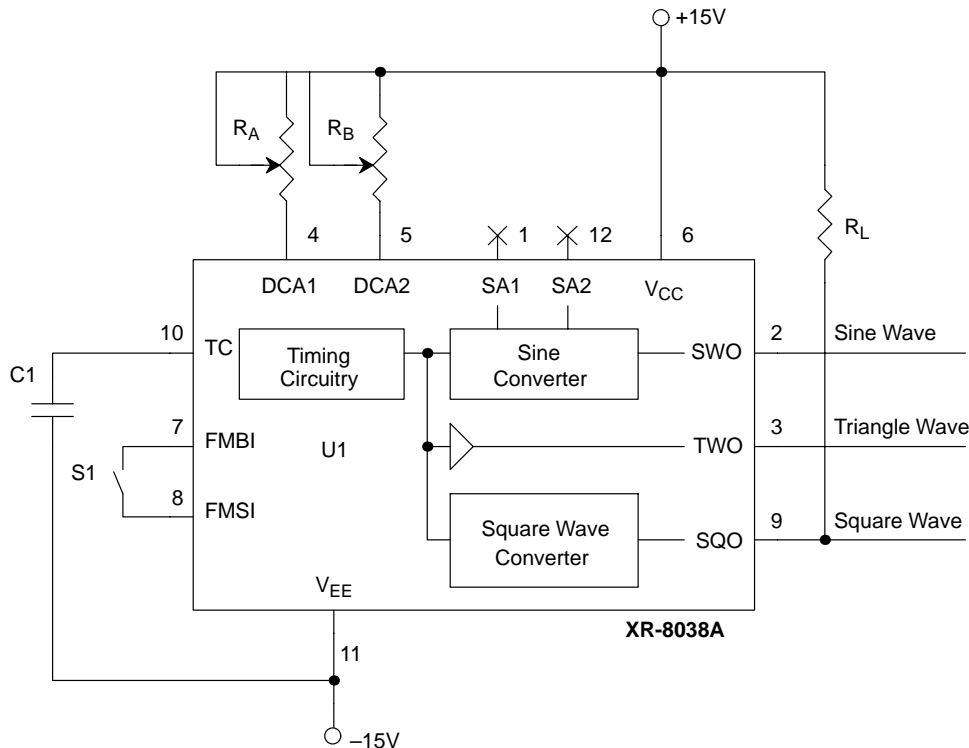

Figure 2. Generalized Test Circuit

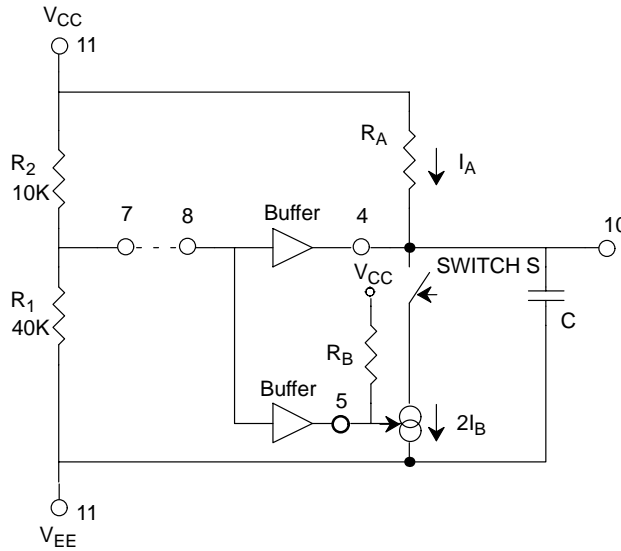

Figure 3. Detailed View of Current Sources I_A and $2I_B$.

WAVEFORM ADJUSTMENT

The symmetry of all waveforms can be adjusted with the external timing resistors. Two possible ways to accomplish this are shown in *Figure 4*, *Figure 5*, and *Figure 6*. Best results are obtained by keeping the timing resistors R_A and R_B separate (*Figure 4*.) R_A controls the rising portion of the triangle and sine wave and the "low" state of the square wave.

The magnitude of the triangle waveform is set at $1/3 V_{CC}$; therefore, the duration of the rising proportion of the triangle is:

$$t_1 = \frac{C \cdot |\Delta V|}{I_A} = \frac{C \cdot \left| \frac{2}{3} V_{CC} - \frac{1}{3} V_{CC} \right|}{\frac{V_{CC}}{5R_A}} = \frac{5}{3} R_A \cdot C$$

The duration of the falling portion of the triangle and sine wave and the "low" state of the square wave is:

$$t_2 = \frac{C \cdot |\Delta V|}{2I_B - I_A} = \frac{C \cdot \left| \frac{2}{3} V_{CC} - \frac{1}{3} V_{CC} \right|}{\frac{2V_{CC}}{5R_B} - \frac{V_{CC}}{5R_A}} = \frac{5}{3} \cdot \frac{R_A R_B C}{2R_A - R_B}$$

Thus a 50% duty cycle is achieved when $R_A = R_B$

If the duty-cycle is to be varied over a small range about 50%, the connection shown in *Figure 5* is slightly more convenient. If no adjustment of the duty cycle is desired,

pins 4 and 5 can be shorted together, as shown in *Figure 6*. This connection, however, carries an inherently larger variation of the duty cycle.

With two separate timing resistors the frequency is given by:

$$f = \frac{1}{t_1 + t_2} = \frac{1}{\frac{5}{3} \cdot R_A C \left(1 + \frac{R_B}{2R_A - R_B} \right)}$$

or, if $R_A = R_B = R$

$$f = \frac{0.3}{RC} \quad (\text{for Figure 4.})$$

If a single timing resistor is used (*Figure 5* and *Figure 6*), the frequency is:

$$f = \frac{0.15}{RC}$$

The frequency of oscillation is independent of supply voltage, even though none of the voltages are regulated inside the integrated circuit. This is due to the fact that both currents and thresholds are direct, linear function of the supply voltage and thus their effects cancel.

DISTORTION ADJUSTMENT

To minimize sine wave distortion, two potentiometers can be connected as shown in *Figure 7*. This configuration allows a reduction of sine wave distortion close to 0.5%.

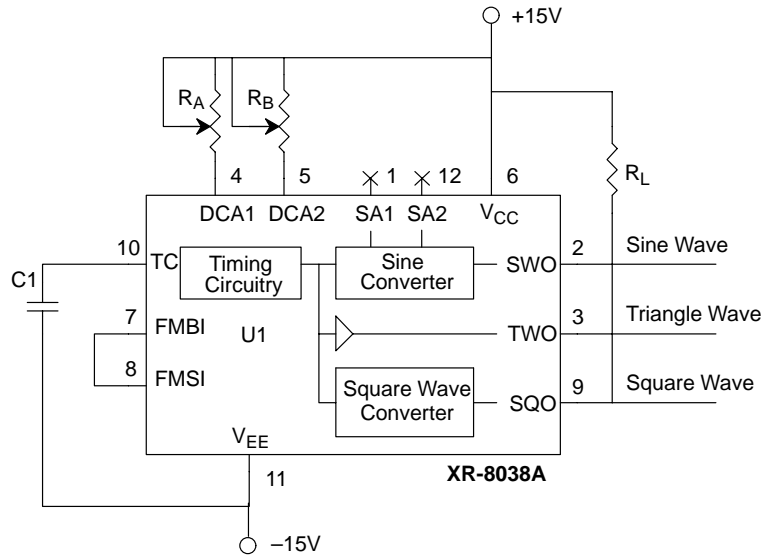

Figure 4. Possible Connection for External Duty Cycle Adjust

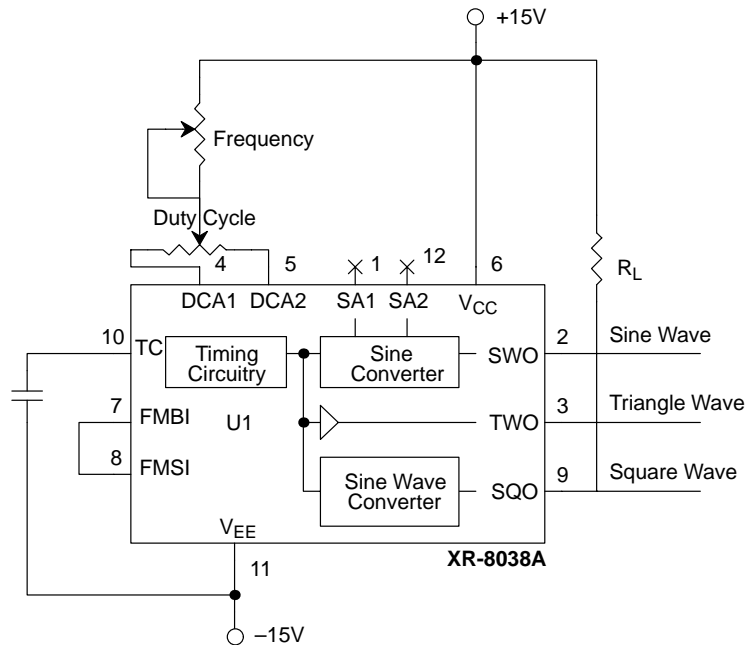

Figure 5. Single Potentiometer for External Duty Cycle Adjust

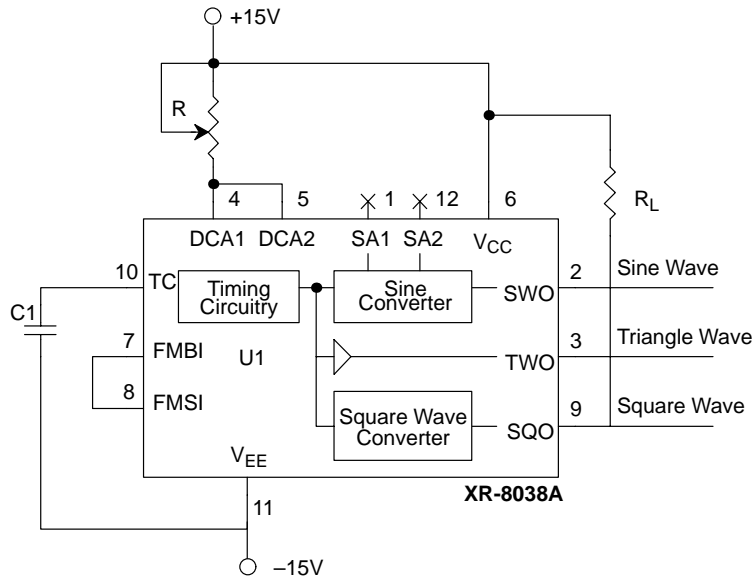

Figure 6. No Duty Cycle Adjust

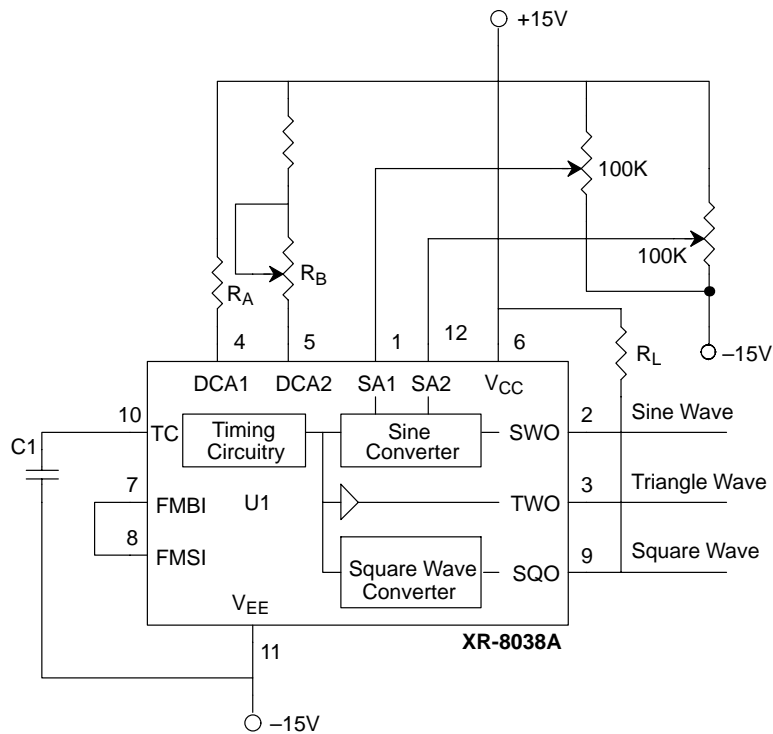

Figure 7. Minimum Sine Wave Distortion

SELECTING TIMING COMPONENTS

For any given output frequency, there is a wide range of R and C combinations that will work. However, certain constraints are placed upon the magnitude of the charging current for optimum performance. At the low end, currents of less than 0.1μA are undesirable because circuit leakages will contribute significant errors at high temperatures. At higher currents ($I > 5\text{mA}$), transistor betas and saturation voltages will contribute increasingly large errors. Optimum performance will be obtained for charging currents of 1μA to 1mA. If pins 7 and 8 are shorted together, the magnitude of the charging current due to R_A can be calculated from:

$$I = \frac{R_1 \cdot V_{CC}}{(R_1 + R_2)} \cdot \frac{1}{R_A} = \frac{V_{CC}}{5R_A}$$

A similar calculation holds for R_B .

When the duty cycle is greater than 60%, the device may not oscillate every time, unless:

1. The rise times of the V+ are 10X times slower than $R_A \cdot C_T$.
2. A 0.1μF capacitor is tied from pin 7 and 8 to ground.

NOTE:

- This is only needed if the duty cycle is powered up with $R_A \gg R_B$.

SINGLE-SUPPLY AND SPLIT-SUPPLY OPERATION

The waveform generator can be operated either from a single power supply (10V to 30V) or a dual power supply ($\pm 5\text{V}$ to $\pm 15\text{V}$). With a single power supply the average levels of the triangle and sine wave are at exactly one half of the supply voltage, while the square wave alternates between $+V_{CC}$ and ground. A split power supply has the

advantage that all waveforms move symmetrically about ground.

The square wave output is not committed. A load resistor can be connected to a different power supply, as long as the applied voltage remains within the breakdown capability of the waveform generator (30V). In this way, the square wave output will be TTL compatible (load resistor connected to +5V) while the waveform generator itself is powered from a higher supply voltage.

FREQUENCY MODULATION AND SWEEP

The frequency of the waveform generator is an inverse function of the dc voltage at pin 8 (measured from $+V_{CC}$). By altering this voltage, frequency modulation is performed.

For small deviations (e.g., $\pm 10\%$), the modulating signal can be applied to pin 8 by merely providing ac coupling with a capacitor, as shown in *Figure 8*. An external resistor between pins 7 and 8 is not necessary, but it can be used to increase input impedance. Without it (i.e. pins 7 and 8 connected together), the input impedance is 8KΩ; with it, this impedance increases to $(R // 8K\Omega)$.

For larger FM deviations or for frequency sweeping, the modulating signal is applied between the positive supply voltage and pin 8 (*Figure 9*.) In this way the entire bias for the current sources is created by the modulating signal and a very large (e.g. 1000:1) sweep range is obtained ($f=0$ at $V_{SWEEP}=0$). Care must be taken, however, to regulate the supply voltage; in this configuration the charge current is no longer a function of the supply voltage (yet the trigger thresholds still are) and thus the frequency becomes dependent on the supply voltage. The potential on pin 8 may be swept from V_{CC} to $2/3 V_{CC}-2V$.

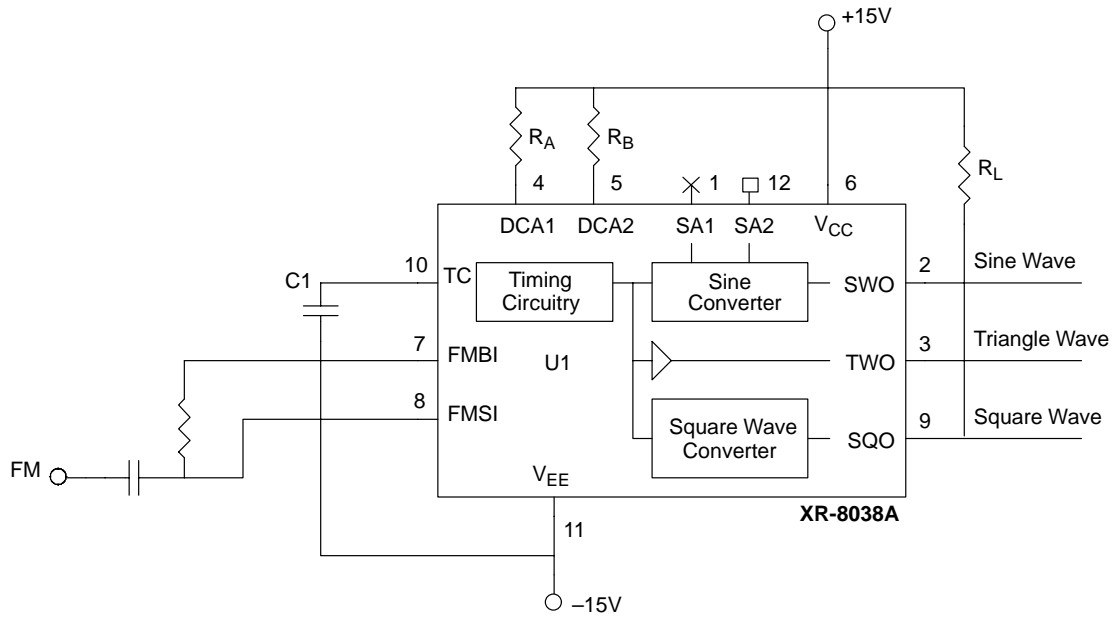

Figure 8. Frequency Modulator

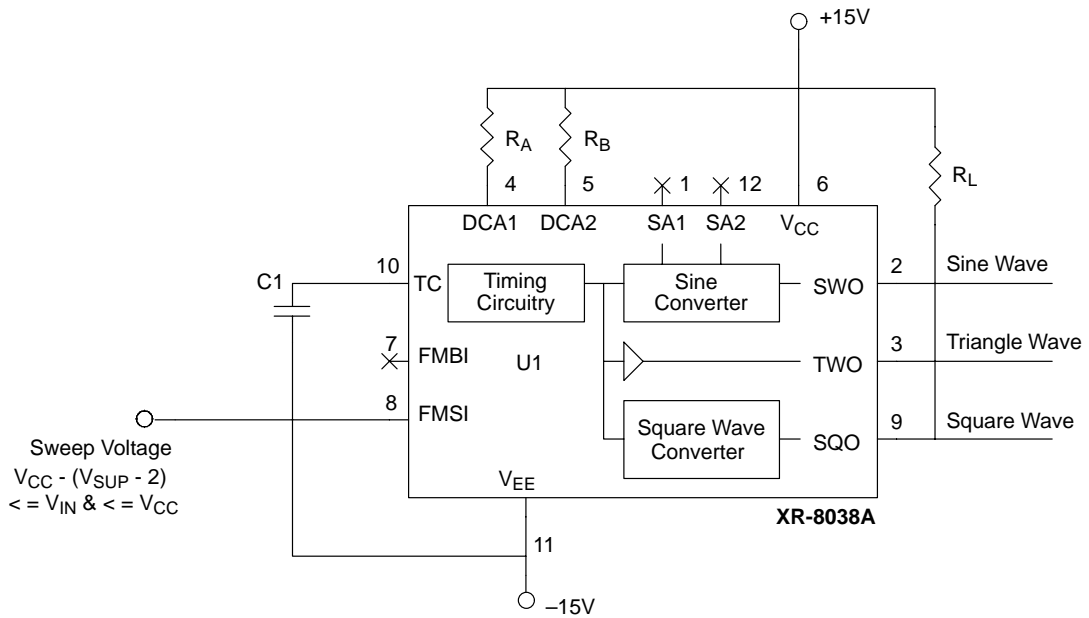

Figure 9. Frequency Sweep

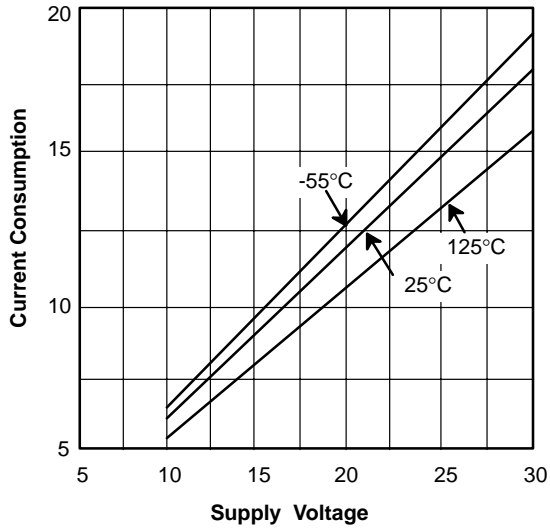

Figure 10. Power Dissipation vs. Supply Voltage

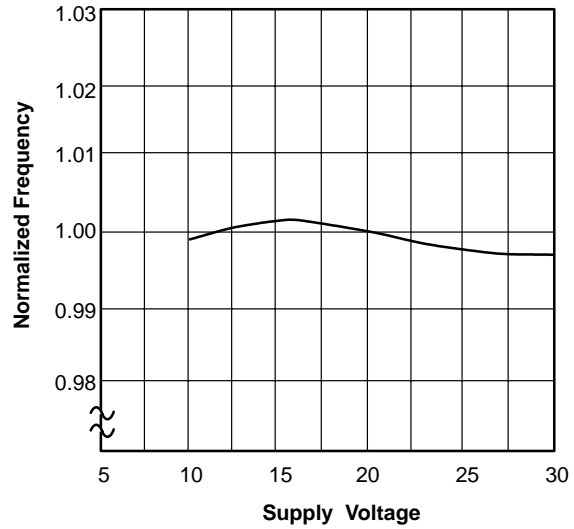

Figure 11. Frequency Drift vs. Power Supply

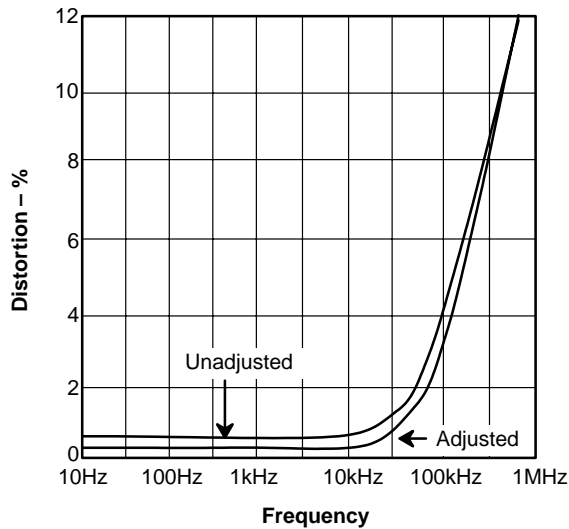
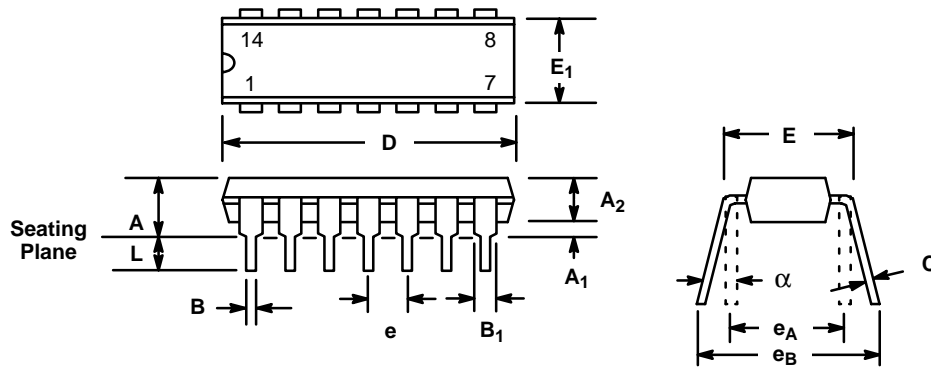

Figure 12. Sine Wave THD vs. Frequency

**14 LEAD PLASTIC DUAL-IN-LINE
(300 MIL PDIP)**



SYMBOL	INCHES		MILLIMETERS	
	MIN	MAX	MIN	MAX
A	0.145	0.210	3.68	5.33
A ₁	0.015	0.070	0.38	1.78
A ₂	0.115	0.195	2.92	4.95
B	0.014	0.024	0.36	0.56
B ₁	0.030	0.070	0.76	1.78
C	0.008	0.014	0.20	0.38
D	0.725	0.795	18.42	20.19
E	0.300	0.325	7.62	8.26
E ₁	0.240	0.280	6.10	7.11
e	0.100 BSC		2.54 BSC	
e _A	0.300 BSC		7.62 BSC	
e _B	0.310	0.430	7.87	10.92
L	0.115	0.160	2.92	4.06
α	0°	15°	0°	15°

Note: The control dimension is the inch column

Notes

Notes

NOTICE

EXAR Corporation reserves the right to make changes to the products contained in this publication in order to improve design, performance or reliability. EXAR Corporation assumes no responsibility for the use of any circuits described herein, conveys no license under any patent or other right, and makes no representation that the circuits are free of patent infringement. Charts and schedules contained here in are only for illustration purposes and may vary depending upon a user's specific application. While the information in this publication has been carefully checked; no responsibility, however, is assumed for inaccuracies.

EXAR Corporation does not recommend the use of any of its products in life support applications where the failure or malfunction of the product can reasonably be expected to cause failure of the life support system or to significantly affect its safety or effectiveness. Products are not authorized for use in such applications unless EXAR Corporation receives, in writing, assurances to its satisfaction that: (a) the risk of injury or damage has been minimized; (b) the user assumes all such risks; (c) potential liability of EXAR Corporation is adequately protected under the circumstances.

Copyright 1992 EXAR Corporation

Datasheet June 1997

Reproduction, in part or whole, without the prior written consent of EXAR Corporation is prohibited.