



CYPRESS

CY28301

Frequency Generator for Intel® Integrated Chipset

Features

- Single chip FTG solution for Intel® Solano/810E/810
- Support SMBus byte Read/Write and block Read/Write operations to simplify system BIOS development
- Vendor ID and revision ID support
- Maximized EMI suppression using Cypress's Spread Spectrum technology
- Low jitter and tightly controlled clock skew
- Two copies of CPU clock
- Thirteen copies of SDRAM clock
- Eight copies of PCI clock
- One copy of synchronous APIC clock
- Three copies of 66-MHz outputs
- Two copies of 48-MHz outputs
- One copy of 14.31818-MHz reference clock

Key Specifications

CPU, SDRAM Outputs Cycle-to-Cycle Jitter: 250 ps
 APIC, 48-MHz, 3V66, PCI Outputs
 Cycle-to-Cycle Jitter: 500 ps
 CPU, 3V66 Output Skew: 175 ps
 SDRAM, APIC, 48-MHz Output Skew: 250 ps
 PCI Output Skew: 500 ps
 CPU to SDRAM Skew (@ 133 MHz) ±0.5 ns
 CPU to SDRAM Skew (@ 100 MHz) 4.5 to 5.5 ns
 CPU to 3V66 Skew (@ 66 MHz) 7.0 to 8.0 ns
 3V66 to PCI Skew (3V66 lead) 1.5 to 3.5 ns
 PCI to APIC Skew ±0.5 ns

Block Diagram

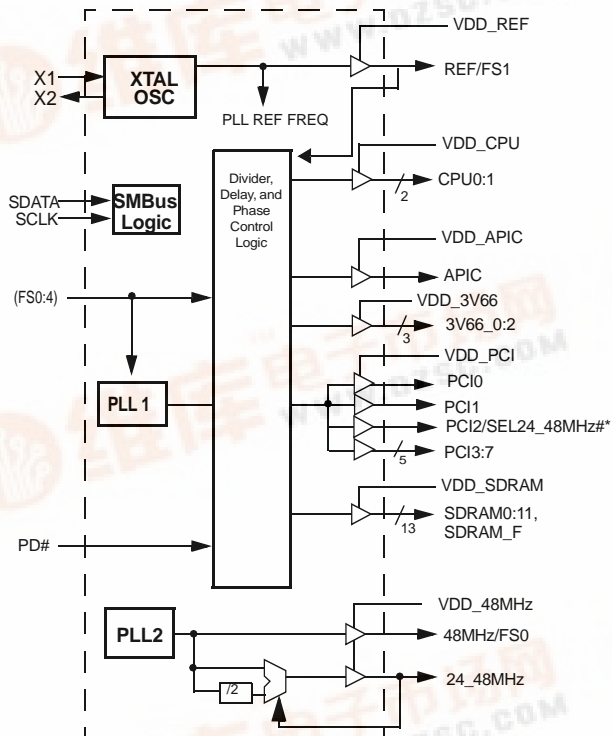

Pin Configuration^[1]

VDD_REF	1	56	REF/FS1*
X1	2	55	VDD_APIC
X2	3	54	APIC
GND_REF	4	53	VDD_CPU
GND_3V66	5	52	CPU0
3V66_0	6	51	CPU1
3V66_1	7	50	GND_CPU
3V66_2	8	49	GND_SDRAM
VDD_3V66	9	48	SDRAM0
VDD_PCI	10	47	SDRAM1
PCI0	11	46	SDRAM2
PCI1	12	45	VDD_SDRAM
PCI2/SEL24_48MHz#*	13	44	SDRAM3
GND_PCI	14	43	SDRAM4
PCI3	15	42	SDRAM5
PCI4	16	41	GND_SDRAM
PCI5	17	40	SDRAM6
VDD_PCI	18	39	SDRAM7
PCI6	19	38	SDRAM_F
PCI7	20	37	VDD_SDRAM
GND_PCI	21	36	GND_48MHz
PD#*	22	35	24_48MHz
SCLK	23	34	48MHz/FS0*
SDATA	24	33	VDD_48MHz
VDD_SDRAM	25	32	VDD_SDRAM
SDRAM11	26	31	SDRAM8
SDRAM10	27	30	SDRAM9
GND_SDRAM	28	29	GND_SDRAM

Note:

1. Internal 100K pull-up resistors present on inputs marked with *. Design should not rely solely on internal pull-up resistor to set I/O pins HIGH.



Pin Definitions

Pin Name	Pin No.	Pin Type	Pin Description
REF/FS1	56	I/O	Reference Clock /Frequency Select 1: 3.3V 14.318-MHz clock output. This pin also serves as the select strap to determine the device operating frequency (as described in <i>Table 5</i>).
X1	2	I	Crystal Input: This pin has dual functions. It can be used as an external 14.318-MHz crystal connection or as an external reference frequency input.
X2	3	O	Crystal Output: An input connection for an external 14.318-MHz crystal connection. If using an external reference, this pin must be left unconnected.
PCI0	11	O	PCI Clock 0: 3.3V 33-MHz PCI clock output.
PCI1	12	O	PCI Clock 1: 3.3V 33-MHz PCI clock output.
PCI2/SEL24_48MHz#	13	O	PCI Clock 2/Select 24 or 48 MHz: 3.3V 33-MHz PCI clock outputs. This pin also serves as the select strap to determine the output frequency for 24_48MHz output. Logic 1 = 24 MHz on pin 35.
PCI3:7	15, 16, 17, 19, 20	O	PCI Clock 3 through 7: 3.3V 33-MHz PCI clock outputs. PCI0:7 can be individually turned off via the SMBus interface.
3V66_0:2	6, 7, 8	O	66-MHz Clock Output: 3.3V output clocks. The operating frequency is controlled by FS0:1 (see <i>Table 5</i>).
48MHz/FS0	34	I/O	48-MHz Output/Frequency Selection 1: 3.3V 48-MHz non-spread spectrum output. This pin also serves as the select strap to determine the device operating frequency (as described in <i>Table 5</i>).
24_48MHz	35	O	24- or 48-MHz Output: 3.3V 24- or 48-MHz non-spread spectrum output.
PD#	22	I	Power-down Input: LVTTL-compatible asynchronous input that places the device in power-down mode when held LOW.
CPU0:1	52, 51	O	CPU Clock Outputs: Clock outputs for the host bus interface. Output frequencies depending on the configuration of FS0:1. Voltage swing is set by VDDQ2.
SDRAM0:11, SDRAM_F	48, 47, 46, 44, 43, 42, 40, 39, 31, 30, 27, 26, 38	O	SDRAM Clock Outputs: 3.3V outputs for SDRAM and chipset. The operating frequency is controlled by FS0:1 (see <i>Table 5</i>).
APIC	54	O	Synchronous APIC Clock Outputs: Clock outputs running synchronous with the PCI clock outputs. Voltage swing set by VDDQ2.
SDATA	24	I/O	Data pin for SMBus circuitry.
SCLK	23	I	Clock pin for SMBus circuitry.
VDD_REF, VDD_3V66, VDD_PCI, VDD_SDRAM, VDD_48MHz	1, 9, 10, 18, 25, 32, 37, 45, 33	P	3.3V Power Connection: Power supply for SDRAM output buffers, PCI output buffers, reference output buffers, and 48-MHz output buffers. Connect to 3.3V.
VDD_CPU, VDD_APIC	53, 55	P	2.5V Power Connection: Power supply for APIC and CPU output buffers. Connect to 2.5V.
GND_REF, GND_3V66, GND_PCI, GND_SDRAM, GND_48MHz, GND_CPU	4, 5, 14, 21, 28, 29, 41, 49, 50, 36	G	Ground Connections: Connect all ground pins to the common system ground plane.

Serial Data Interface

The CY28301 features a two-pin, serial data interface that can be used to configure internal register settings that control particular device functions.

Data Protocol

The clock driver serial protocol supports byte/word Write, byte/word Read, block Write, and block Read operations from

the controller. For block Write/Read operation, the bytes must be accessed in sequential order from lowest to highest byte with the ability to stop after any complete byte has been transferred. For byte/word Write and byte Read operations, the system controller can access individual indexed bytes. The offset of the indexed byte is encoded in the command code.

The definition for the command code is defined as follows.

Table 1. Command Code Definition

Bit	Descriptions
7	0 = Block Read or block Write operation 1 = Byte/Word Read or byte/word Write operation
6:0	Byte offset for byte/word Read or Write operation. For block Read or Write operations, these bits need to be set at '0000000.'

Table 2. Block Read and Block Write Protocol

Block Write Protocol		Block Read Protocol	
Bit	Description	Bit	Description
1	Start	1	Start
2:8	Slave address – 7 bits	2:8	Slave address – 7 bits
9	Write	9	Write
10	Acknowledge from slave	10	Acknowledge from slave
11:18	Command code – 8-bits '00000000' stands for block operation	11:18	Command code – 8 bits '00000000' stands for block operation
19	Acknowledge from slave	19	Acknowledge from slave
20:27	Byte count – 8 bits	20	Repeat start
28	Acknowledge from slave	21:27	Slave address – 7 bits
29:36	Data byte 0 – 8 bits	28	Read
37	Acknowledge from slave	29	Acknowledge from slave
38:45	Data byte 1 – 8 bits	30:37	Byte count from slave – 8 bits
46	Acknowledge from slave	38	Acknowledge
...	Data byte N/Slave acknowledge...	39:46	Data byte from slave – 8 bits
...	Data byte N – 8 bits	47	Acknowledge
...	Acknowledge from slave	48:55	Data byte from slave – 8 bits
...	Stop	56	Acknowledge
		...	Data bytes from slave/acknowledge
		...	Data byte N from slave – 8 bits
		...	Not acknowledge
		...	Stop

Table 3. Word Read and Word Write Protocol

Word Write Protocol		Word Read Protocol	
Bit	Description	Bit	Description
1	Start	1	Start
2:8	Slave address – 7 bits	2:8	Slave address – 7 bits
9	Write	9	Write
10	Acknowledge from slave	10	Acknowledge from slave
11:18	Command Code – 8-bits '1xxxxxxx' stands for byte or word operation bit[6:0] of the command code represents the offset of the byte to be accessed	11:18	Command code – 8 bits '1xxxxxxx' stands for byte or word operation bit[6:0] of the command code represents the offset of the byte to be accessed
19	Acknowledge from slave	19	Acknowledge from slave
20:27	Data byte low – 8 bits	20	Repeat start
28	Acknowledge from slave	21:27	Slave address – 7 bits
29:36	Data byte high – 8 bits	28	Read
37	Acknowledge from slave	29	Acknowledge from slave
38	Stop	30:37	Data byte low from slave – 8 bits
		38	Acknowledge
		39:46	Data byte high from slave – 8 bits
		47	Not acknowledge
		48	Stop

Table 4. Byte Read and Byte Write Protocol

Byte Write Protocol		Byte Read Protocol	
Bit	Description	Bit	Description
1	Start	1	Start
2:8	Slave address – 7 bits	2:8	Slave address – 7 bits
9	Write	9	Write
10	Acknowledge from slave	10	Acknowledge from slave
11:18	Command code 8 – bits '1xxxxxxx' stands for byte operation bit[6:0] of the command code represents the offset of the byte to be accessed	11:18	Command code – 8 bits '1xxxxxxx' stands for byte operation bit[6:0] of the command code represents the offset of the byte to be accessed
19	Acknowledge from slave	19	Acknowledge from slave
20:27	Data byte 8 – bits	20	Repeat start
28	Acknowledge from slave	21:27	Slave address – 7 bits
29	Stop	28	Read
		29	Acknowledge from slave
		30:37	Data byte from slave – 8 bits
		38	Not Acknowledge
		39	Stop

CY28301 Serial Configuration Map

1. The serial bits will be read by the clock driver in the following order:

Byte 0 – Bits 7, 6, 5, 4, 3, 2, 1, 0

Byte 1 – Bits 7, 6, 5, 4, 3, 2, 1, 0

Byte N – Bits 7, 6, 5, 4, 3, 2, 1, 0

2. All unused register bits (reserved and N/A) should be written to a “0” level.

3. All register bits labeled “Initialize to 0” must be written to “0” during initialization.

Byte 0: Control Register 0

Bit	Pin#	Name	Default	Description
Bit 7	–	SEL1	0	See 5
Bit 6	–	SEL0	0	See 5
Bit 5	–	Reserved	0	Reserved
Bit 4	–	Reserved	0	Reserved
Bit 3	–	FS_Override	0	0 = Select operating frequency by FS[1:0] input pins 1 = Select operating frequency by SEL[1:0] settings
Bit 2	–	Spread Select2	0	‘000’ = Normal (spread off) ‘001’ = Test mode ‘010’ = Reserved ‘011’ = Three-stated ‘100’ = –0.5% ‘101’ = –0.75% ‘110’ = –1.0% ‘111’ = –0.3%
Bit 1	–	Spread Select1	0	
Bit 0	–	Spread Select0	0	

Byte 1: Control Register 1

Bit	Pin#	Name	Default	Description
Bit 7	56	Latched FS1 input	X	Latched FS[1:0] inputs. These bits are Read-only.
Bit 6	34	Latched FS0 input	X	
Bit 5	–	Reserved	0	Reserved
Bit 4	–	Reserved	0	Reserved
Bit 3	–	Reserved	0	Reserved
Bit 2	–	Reserved	0	Reserved
Bit 1	56	REF	1	(Active/Inactive)
Bit 0	56	REF_DRV	0	REF Clock output drive strength 0 = Normal 1 = High drive

Byte 2: Control Register 2

Bit	Pin#	Name	Default	Description
Bit 7	20	PCI7	1	(Active/Inactive)
Bit 6	19	PCI6	1	(Active/Inactive)
Bit 5	17	PCI5	1	(Active/Inactive)
Bit 4	16	PCI4	1	(Active/Inactive)
Bit 3	15	PCI3	1	(Active/Inactive)
Bit 2	13	PCI2	1	(Active/Inactive)
Bit 1	12	PCI1	1	(Active/Inactive)
Bit 0	11	PCI0	1	(Active/Inactive)

Byte 3: Control Register 3

Bit	Pin#	Name	Default	Description
Bit 7	8	3V66_2	1	(Active/Inactive)
Bit 6	7	3V66_1	1	(Active/Inactive)
Bit 5	6	3V66_0	1	(Active/Inactive)
Bit 4	54	APIC	1	(Active/Inactive)
Bit 3	–	Reserved	0	Reserved
Bit 2	–	Reserved	0	Reserved
Bit 1	51	CPU1	1	(Active/Inactive)
Bit 0	52	CPU0	1	(Active/Inactive)

Byte 4: Control Register 4

Bit	Pin#	Name	Default	Description
Bit 7	39	SDRAM7	1	(Active/Inactive)
Bit 6	40	SDRAM6	1	(Active/Inactive)
Bit 5	42	SDRAM5	1	(Active/Inactive)
Bit 4	43	SDRAM4	1	(Active/Inactive)
Bit 3	44	SDRAM3	1	(Active/Inactive)
Bit 2	46	SDRAM2	1	(Active/Inactive)
Bit 1	47	SDRAM1	1	(Active/Inactive)
Bit 0	48	SDRAM0	1	(Active/Inactive)

Byte 5: Control Register 5

Bit	Pin#	Name	Default	Description
Bit 7	–	Reserved	0	Reserved
Bit 6	–	Reserved	0	Reserved
Bit 5	–	Reserved	0	Reserved
Bit 4	38	SDRAM_F	1	(Active/Inactive)
Bit 3	26	SDRAM11	1	(Active/Inactive)
Bit 2	27	SDRAM10	1	(Active/Inactive)
Bit 1	30	SDRAM9	1	(Active/Inactive)
Bit 0	31	SDRAM8	1	(Active/Inactive)

Byte 6: Vendor ID and Revision ID Register (Read-only)

Bit	Name	Default	Pin Description
Bit 7	Revision_ID3	0	Revision ID bit[3]
Bit 6	Revision_ID2	0	Revision ID bit[2]
Bit 5	Revision_ID1	0	Revision ID bit[1]
Bit 4	Revision_ID0	0	Revision ID bit[0]
Bit 3	Vendor_ID3	1	Bit[3] of Cypress's Vendor ID. This bit is Read-only.
Bit 2	Vendor_ID2	0	Bit[2] of Cypress's Vendor ID. This bit is Read-only.
Bit 1	Vendor_ID1	0	Bit[1] of Cypress's Vendor ID. This bit is Read-only.
Bit 0	Vendor_ID0	0	Bit[0] of Cypress's Vendor ID. This bit is Read-only.

Byte 7: Control Register 7

Bit	Pin#	Name	Default	Pin Description
Bit 7	–	Reserved	0	Reserved
Bit 6	35	24_48MHz_DRV	1	0 = Norm, 1 = High drive
Bit 5	34	48MHz_DRV	1	0 = Norm, 1 = High drive
Bit 4	–	Reserved	0	Reserved
Bit 3	35	24_48MHz	1	(Active/Inactive)
Bit 2	34	48 MHz	1	(Active/Inactive)
Bit 1	–	Reserved	0	Reserved
Bit 0	–	Reserved	0	Reserved

Byte 8: Reserved Register

Bit	Name	Default	Pin Description
Bit 7	PCI_Skew1	0	PCI skew control 00 = Normal 01 = –500 ps 10 = Reserved 11 = +500 ps
Bit 6	PCI_Skew0	0	
Bit 5	Reserved	1	Reserved. Write with '1'
Bit 4	Reserved	1	Reserved. Write with '1'
Bit 3	Reserved	1	Reserved. Write with '1'
Bit 2	Reserved	1	Reserved. Write with '1'
Bit 1	Reserved	1	Reserved. Write with '1'
Bit 0	Reserved	0	Reserved

Byte 9: Reserved Register

Bit	Name	Default	Pin Description
Bit 7	SDRAM_DRV	0	SDRAM clock output drive strength 0 = Normal 1 = High Drive
Bit 6	PCI_DRV	0	PCI and AGP clock output drive strength 0 = Normal 1 = High drive
Bit 5	Reserved	0	Reserved
Bit 4	Reserved	0	Reserved
Bit 3	Reserved	0	Reserved
Bit 2	Reserved	0	Reserved

Byte 9: Reserved Register (continued)

Bit	Name	Default	Pin Description
Bit 1	Reserved	0	Reserved
Bit 0	Reserved	0	Reserved

Byte 10: Reserved Register

Bit	Name	Default	Description
Bit 7	CPU_Skew2	0	CPU skew control 000 = Normal 001 = -150 ps 010 = -300 ps 011 = -450 ps 100 = +150 ps 101 = +300 ps 110 = +450 ps 111 = +600 ps
Bit 6	CPU_Skew1	0	
Bit 5	CPU_Skew0	0	
Bit 4	SDRAM_Skew2	0	SDRAM skew control 000 = Normal 001 = -150 ps 010 = -300 ps 011 = -450 ps 100 = +150 ps 101 = +300 ps 110 = +450 ps 111 = +600 ps
Bit 3	SDRAM_Skew1	0	
Bit 2	SDRAM_Skew0	0	
Bit 1	AGP_Skew1	0	AGP skew control 00 = Normal 01 = -150 ps 10 = +150 ps 11 = +300 ps
Bit 0	AGP_Skew0	0	

Byte 11: Reserved Register

Bit	Name	Default	Pin Description
Bit 7	Reserved	0	Reserved
Bit 6	Reserved	0	Reserved
Bit 5	Reserved	0	Reserved
Bit 4	Reserved	0	Reserved
Bit 3	Reserved	0	Reserved
Bit 2	Reserved	0	Reserved
Bit 1	Reserved	0	Reserved
Bit 0	Reserved	0	Reserved

Byte 12: Reserved Register

Bit	Name	Default	Pin Description
Bit 7	Reserved	0	Reserved
Bit 6	Reserved	0	Reserved
Bit 5	Reserved	0	Reserved
Bit 4	Reserved	0	Reserved
Bit 3	Reserved	0	Reserved
Bit 2	Reserved	0	Reserved
Bit 1	Reserved	0	Reserved
Bit 0	Reserved	0	Reserved

Byte 13: Reserved Register

Bit	Name	Default	Pin Description
Bit 7	Reserved	0	Reserved
Bit 6	Reserved	0	Reserved
Bit 5	Reserved	0	Reserved
Bit 4	Reserved	0	Reserved
Bit 3	Reserved	0	Reserved
Bit 2	Reserved	0	Reserved
Bit 1	Reserved	0	Reserved
Bit 0	Reserved	0	Reserved

Byte 14: Reserved Register

Bit	Name	Default	Description
Bit 7	Reserved	0	Reserved
Bit 6	Reserved	0	Reserved
Bit 5	Reserved	0	Reserved
Bit 4	Reserved	0	Reserved
Bit 3	Reserved	0	Reserved
Bit 2	Reserved	0	Reserved
Bit 1	Reserved	0	Reserved
Bit 0	Reserved	0	Reserved

Byte 15: Reserved Register

Bit	Pin#	Name	Default	Description
Bit 7	–	Reserved	0	Reserved
Bit 6	–	Reserved	0	Reserved
Bit 5	–	Reserved	0	Reserved
Bit 4	–	Reserved	0	Reserved
Bit 3	–	Reserved	0	Reserved
Bit 2	–	Reserved	0	Reserved
Bit 1	–	Reserved	1	Reserved. Write with '1'
Bit 0	–	Reserved	1	Reserved. Write with '1'

Byte 16: Reserved Register

Bit	Pin#	Name	Default	Description
Bit 7	–	Reserved	0	Reserved
Bit 6	–	Reserved	0	Reserved
Bit 5	–	Reserved	0	Reserved
Bit 4	–	Reserved	0	Reserved
Bit 3	–	Reserved	0	Reserved
Bit 2	–	Reserved	0	Reserved
Bit 1	–	Reserved	0	Reserved

Byte 17: Reserved Register

Bit	Pin#	Name	Default	Description
Bit 7	–	Reserved	0	Reserved
Bit 6	–	Reserved	0	Reserved

Byte 17: Reserved Register (continued)

Bit	Pin#	Name	Default	Description
Bit 5	–	Reserved	0	Reserved
Bit 4	–	Reserved	0	Reserved
Bit 3	–	Reserved	0	Reserved
Bit 2	–	Reserved	0	Reserved
Bit 1	–	Reserved	0	Reserved

Table 5. Frequency Selections through HW Strap Option and Serial Data Interface Data Bytes

Input Conditions		Output Frequency				
FS1	FS0	CPU	SDRAM	3V66	PCI	APIC
SEL1	SEL0					
0	0	66.6	100.0	66.6	33.3	16.6
0	1	100.0	100.0	66.6	33.3	16.6
1	0	133.3	133.3	66.6	33.3	16.6
1	1	133.3	100.0	66.6	33.3	16.6

DC Electrical Characteristics^[2]

DC parameters must be sustainable under steady state (DC) conditions.

Absolute Maximum DC Power Supply

Parameter	Description	Min.	Max.	Unit
V _{DDQ3}	3.3V Core Supply Voltage	–0.5	4.6	V
V _{DDQ2}	2.5V I/O Supply Voltage	–0.5	3.6	V
T _S	Storage Temperature	–65	150	°C

Absolute Maximum DC I/O

Parameter	Description	Min.	Max.	Unit
V _{i/o3}	3.3V Core Supply Voltage	–0.5	4.6	V
V _{i/o3}	2.5V I/O Supply Voltage	–0.5	3.6	V
ESD prot.	Input ESD Protection	2000		V

DC Operating Requirements

Parameter	Description	Condition	Min.	Max.	Unit
V _{DD3}	3.3V Core Supply Voltage	3.3V ±5%	3.135	3.465	V
V _{DDQ3}	3.3V I/O Supply Voltage	3.3V ±5%	3.135	3.465	V
V _{DDQ2}	2.5V I/O Supply Voltage	2.5V ±5%	2.375	2.625	V
V _{DD3} = 3.3V ±5%					
V _{ih3}	3.3V Input High Voltage	V _{DD3}	2.0	V _{DD} + 0.3	V
V _{il3}	3.3V Input Low Voltage		V _{SS} – 0.3	0.8	V
I _{il}	Input Leakage Current ^[3]	0 < V _{in} < V _{DD3}	–5	+5	µA
V _{DDQ2} = 2.5V ±5%					
V _{oh2}	2.5V Output High Voltage	I _{oh} = (–1 mA)	2.0		V
V _{ol2}	2.5V Output Low Voltage	I _{ol} = (1 mA)		0.4	V

Note:

- Multiple Supplies:** The voltage on any input or I/O pin cannot exceed the power pin during power-up. Power supply sequencing is NOT required.
- Input leakage current does not include inputs with pull-up or pull-down resistors.

DC Operating Requirements (continued)

Parameter	Description	Condition	Min.	Max.	Unit
$V_{DDQ3} = 3.3V \pm 5\%$					
V_{oh3}	3.3V Output High Voltage	$I_{oh} = (-1 \text{ mA})$.4		V
V_{ol3}	3.3V Output Low Voltage	$I_{ol} = (1 \text{ mA})$		0.4	V
$V_{DDQ3} = 3.3V \pm 5\%$					
V_{poh3}	PCI Bus Output High Voltage	$I_{oh} = (-1 \text{ mA})$	2.4		V
V_{pol3}	PCI Bus Output Low Voltage	$I_{ol} = (1 \text{ mA})$		0.55	V
C_{in}	Input Pin Capacitance			5	pF
C_{xtal}	Xtal Pin Capacitance		13.5	22.5	pF
C_{out}	Output Pin Capacitance			6	pF
L_{pin}	Pin Inductance		0	7	nH
T_a	Ambient Temperature	No airflow	0	70	°C

AC Electrical Characteristics^[2] ($T_A = 0^\circ\text{C}$ to $+70^\circ\text{C}$, $V_{DDQ3} = 3.3\text{V} \pm 5\%$, $V_{DDQ2} = 2.5\text{V} \pm 5\%$, $f_{XTL} = 14.31818\text{ MHz}$)

Parameter	Description	66.6-MHz Host		100-MHz Host		133-MHz Host		Unit	Notes
		Min.	Max.	Min.	Max.	Min.	Max.		
CPUCLK									
T_{Period}	Host/CPUCLK Period	15.0	15.5	10.0	10.5	7.5	8.0	ns	4
T_{HIGH}	Host/CPUCLK High Time	5.2	N/A	3.0	N/A	1.87	N/A	ns	5
T_{LOW}	Host/CPUCLK Low Time	5.0	N/A	2.8	N/A	1.67	N/A	ns	6
T_{RISE}	Host/CPUCLK Rise Time	0.4	1.6	0.4	1.6	0.4	1.6	ns	
T_{FALL}	Host/CPUCLK Fall Time	0.4	1.6	0.4	1.6	0.4	1.6	ns	
SDRAM									
T_{Period}	SDRAM CLK Period	10.0	10.5	10.0	10.5	10.0	10.5	ns	4
T_{HIGH}	SDRAM CLK High Time	3.0	N/A	3.0	N/A	3.0	N/A	ns	5
T_{LOW}	SDRAM CLK Low Time	2.8	N/A	2.8	N/A	2.8	N/A	ns	6
T_{RISE}	SDRAM CLK Rise Time	0.4	1.6	0.4	1.6	0.4	1.6	ns	
T_{FALL}	SDRAM CLK Fall Time	0.4	1.6	0.4	1.6	0.4	1.6	ns	
APIC									
T_{Period}	APIC CLK Period	60.0	64.0	60.0	N/A	60.0	64.0	ns	4
T_{HIGH}	APIC CLK High Time	25.5	N/A	25.5	N/A	25.5	N/A	ns	5
T_{LOW}	APIC CLK Low Time	25.3	N/A	25.30	N/A	25.30	N/A	ns	6
T_{RISE}	APIC CLK Rise Time	0.4	1.6	0.4	1.6	0.4	1.6	ns	
T_{FALL}	APIC CLK Fall Time	0.4	1.6	0.4	1.6	0.4	1.6	ns	
3V66									
T_{Period}	3V66 CLK Period	15.0	16.0	15.0	16.0	15.0	16.0	ns	4, 8
T_{HIGH}	3V66 CLK High Time	5.25	N/A	5.25	N/A	5.25	N/A	ns	5
T_{LOW}	3V66 CLK Low Time	5.05	N/A	5.05	N/A	5.05	N/A	ns	6
T_{RISE}	3V66 CLK Rise Time	0.5	2.0	0.5	2.0	0.5	2.0	ns	
T_{FALL}	3V66 CLK Fall Time	0.5	2.0	0.5	2.0	0.5	2.0	ns	
PCI									
T_{Period}	PCI CLK Period	30.0	N/A	30.0	N/A	30.0	N/A	ns	4, 7
T_{HIGH}	PCI CLK High Time	12.0	N/A	12.0	N/A	12.0	N/A	ns	5
T_{LOW}	PCI CLK Low Time	12.0	N/A	12.0	N/A	12.0	N/A	ns	6
T_{RISE}	PCI CLK Rise Time	0.5	2.0	0.5	2.0	0.5	2.0	ns	
T_{FALL}	PCI CLK Fall Time	0.5	2.0	0.5	2.0	0.5	2.0	ns	
$t_{\text{pZL}}, t_{\text{pZH}}$	Output Enable Delay (All outputs)	1.0	10.0	1.0	10.0	1.0	10.0	ns	
$t_{\text{pLZ}}, t_{\text{pZH}}$	Output Disable Delay (All outputs)	1.0	10.0	1.0	10.0	1.0	10.0	ns	
t_{stable}	All Clock Stabilization from Power-Up		3		3		3	ms	

Notes:

- Period, jitter, offset, and skew measured on the rising edge at 1.25 for 2.5V clocks and at 1.5V for 3.3V clocks.
- The time specified is measured from when V_{DDQ3} achieves its nominal operating level (typical condition $V_{DDQ3} = 3.3\text{V}$) until the frequency output is stable and operating within specifications.
- T_{RISE} and T_{FALL} are measured as transitions through the threshold region $V_{ol} = 0.4\text{V}$ and $V_{oh} = 2.0\text{V}$ (1 mA) JEDEC specification.
- T_{HIGH} is measured at 2.0V for 2.5V outputs, and 2.4V for 3.3V outputs.
- T_{LOW} is measured at 0.4V for all outputs.

Group Skew and Jitter Limits

Output Group	Pin-Pin Skew Max.	Cycle-Cycle Jitter	Duty Cycle	Nom. V _{DD}	Skew, Jitter Measure Point
CPU	175 ps	250 ps	45/55	2.5V	1.25V
SDRAM	250 ps	250 ps	45/55	3.3V	1.5V
APIC	250 ps	500 ps	45/55	2.5V	1.25V
48MHz	250 ps	500 ps	45/55	3.3V	1.5V
3V66	175 ps	500 ps	45/55	3.3V	1.5V
PCI	500 ps	500 ps	45/55	3.3V	1.5V
REF	N/A	1000 ps	45/55	3.3V	1.5V

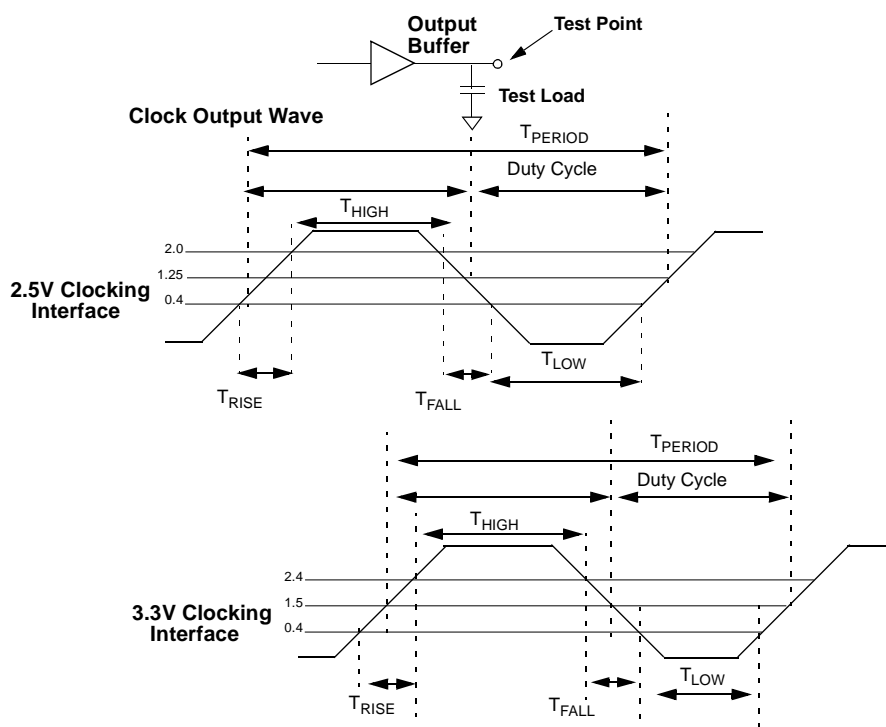
Figure 1. Output Buffer

Ordering Information

Ordering Code	Package Type	Operating Range
CY28301PVC	56-pin SSOP (300 mils)	Commercial, 0°C to 70°C
CY28301PVCT	56-pin SSOP (300 mils) - Tape and Reel	Commercial, 0°C to 70°C

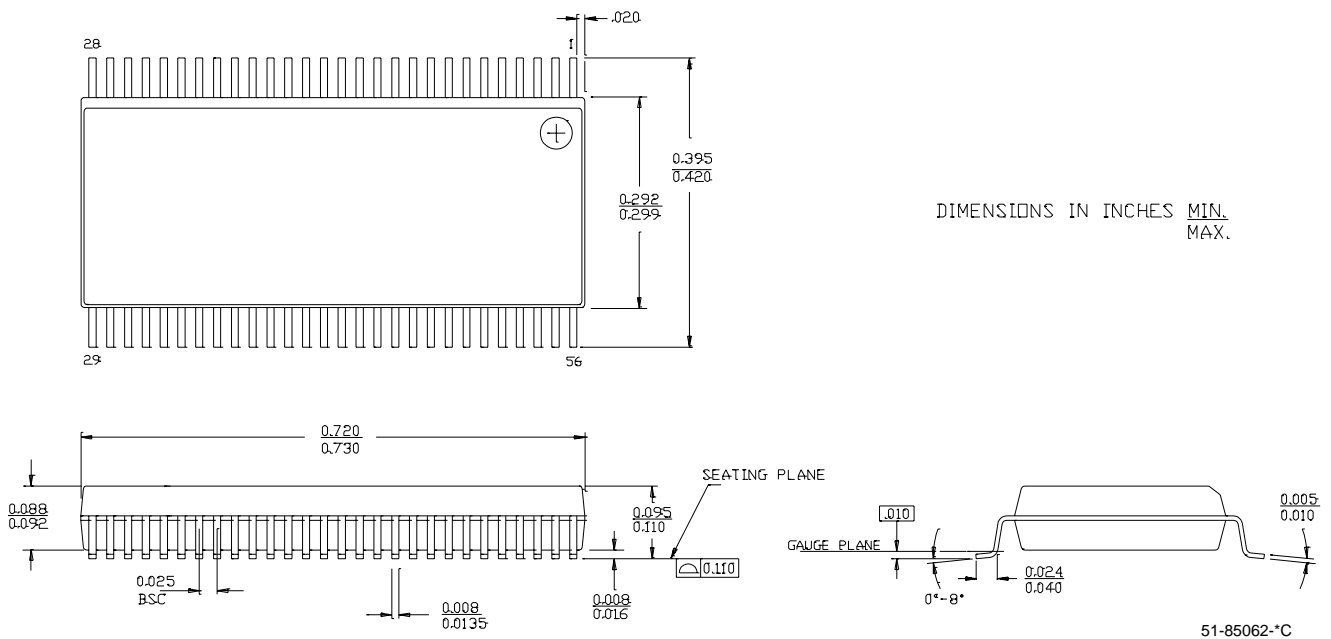
Package Drawing and Dimension
56-Lead Shrink Small Outline Package O56

Intel is a registered trademark of Intel Corporation. All product or company names mentioned in this document are the trademarks of their respective holders.

Document History Page

Document Title: CY28301 Frequency Generator for Intel® Integrated Chipset Document Number: 38-07011				
REV.	ECN NO.	Issue Date	Orig. of Change	Description of Change
**	106533	06/27/01	IKA	Change from Spec #: 38-01096 to 38-07011 Changed I2C to SMBus and Updated Byte Tables
*A	109365	11/06/01	IKA	Revise AC and DC Tables
*B	118785	09/25/02	DMG	Corrected the spread spectrum values in Bits 0 to 2 in Byte 0 (Control register 0) table to match the device. Changed the Package Drawing and Dimension to CY Standard. Added the tape and reel option in the ordering information table.
*C	122717	12/21/02	RBI	Added power up requirements to operating conditions information.