



CYPRESS

PRELIMINARY

CY28324

FTG for Intel® Pentium® 4 CPU and Chipsets

Features

- Compatible to Intel® CK-00, CK-Titan & CK-408 Clock Synthesizer/Driver Specifications
- System frequency synthesizer for Intel 850, Brookdale (845) and Brookdale - G Pentium® 4 Chipsets
- Programmable clock output frequency with less than 1 MHz increment
- Integrated fail-safe Watchdog Timer for system recovery
- Automatically switch to HW selected or SW programmed clock frequency when Watchdog Timer time-out
- Capable of generating system RESET after a Watchdog Timer time-out occurs or a change in output frequency via SMBus interface

- Support SMBus byte read/write and block read/write operations to simplify system BIOS development
- Vendor ID and Revision ID support
- Programmable drive strength support
- Programmable output skew support
- Power management control inputs
- Available in 48-pin SSOP

CPU	3V66	PCI	REF	48M	24_48M
x 2	x 4	x 10	x 2	x 1	x 1

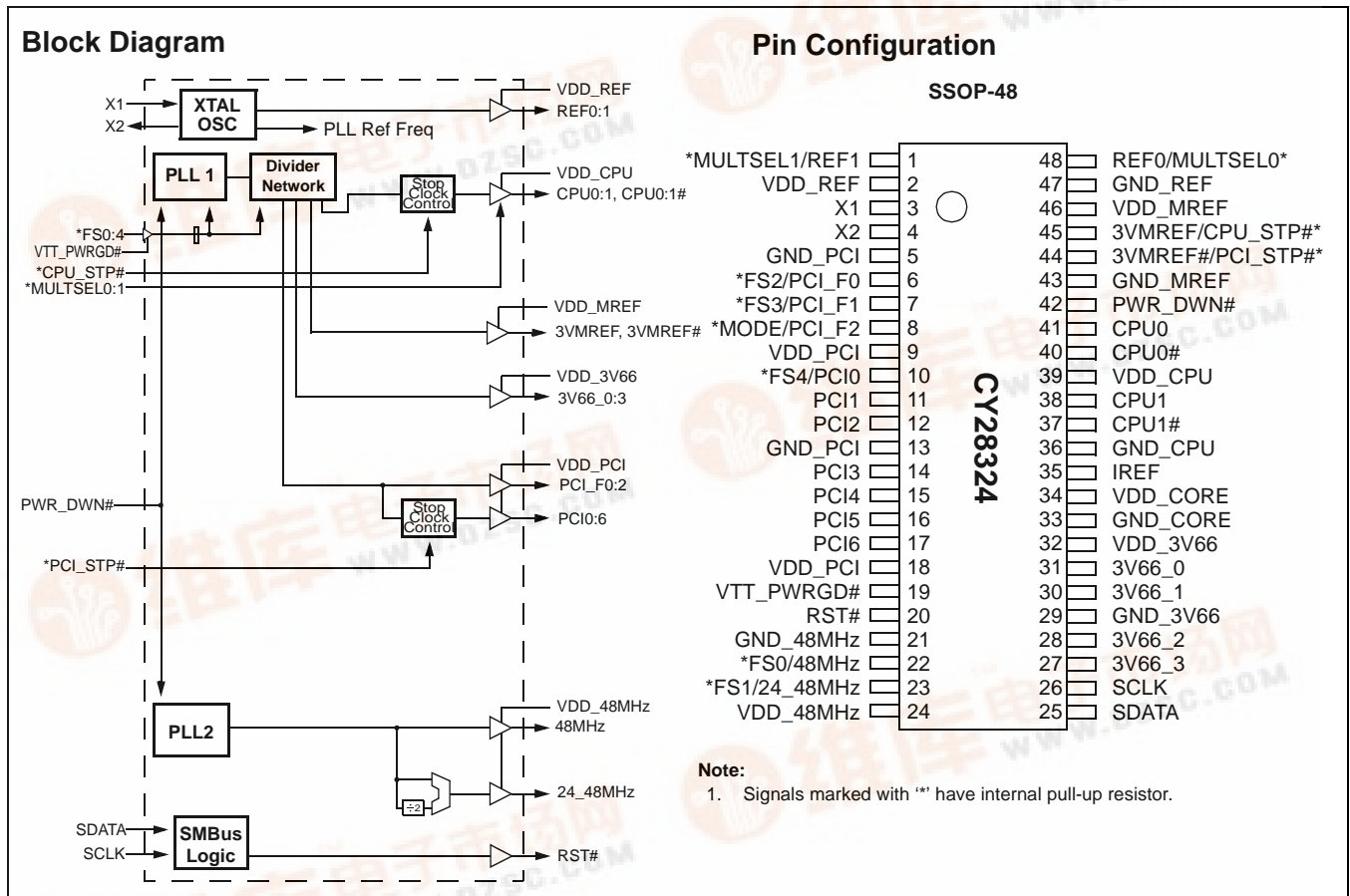

Intel and Pentium are registered trademarks of Intel Corporation.



Pin Definitions

Pin Name	Pin No.	Pin Type	Pin Description
X1	3	I	Crystal Connection or External Reference Frequency Input: This pin has dual functions. It can be used as an external 14.318-MHz crystal connection or as an external reference frequency input.
X2	4	O	Crystal Connection: Connection for an external 14.318-MHz crystal. If using an external reference, this pin must be left unconnected.
REF0/MULTSELO	48	I/O	Reference Clock 0/Current Multiplier Selection 0: 3.3V 14.318-MHz clock output. This pin also serves as a power-on strap option to determine the current multiplier for the CPU clock outputs. The MULTSEL1:0 definitions are as follows: MULTSEL1:0 00 = I _{OH} is 4 x IREF 01 = I _{OH} is 5 x IREF 10 = I _{OH} is 6 x IREF 11 = I _{OH} is 7 x IREF
REF1/MULTSEL1	1	I/O	Reference Clock 1/Current Multiplier Selection 1: 3.3V 14.318-MHz clock output. This pin also serves as a power-on strap option to determine the current multiplier for the CPU clock outputs. The MULTSEL1:0 definitions are as follows: MULTSEL1:0 00 = I _{OH} is 4 x IREF 01 = I _{OH} is 5 x IREF 10 = I _{OH} is 6 x IREF 11 = I _{OH} is 7 x IREF
CPU0:1, CPU0:1#	41, 38, 40, 37	O	CPU Clock Outputs: Frequency is set by the FS0:4 inputs or through the serial input interface.
3VMREF/CPU_STP#	45	I/O	Memory Reference Clock/CPU Output Control: The function of this pin is controlled by the Mode input pin. When Mode input is sampled HIGH during power-on reset, this pin will be configured as 3VMREF output. When Mode input is sampled LOW during power-on reset, this pin will be configured as CPU_STP# input. 3VMREF is a 3.3V output running at half the frequency of the CPU output clock. CPU_STP# is a 3.3V LVTTTL compatible input that disables CPU0, CPU0#, CPU1 and CPU1# outputs.
3VMREF#/PCI_STP#	44	I/O	Memory Reference Clock/PCI Output Control: The function of this pin is controlled by the Mode input pin. When Mode input is sampled HIGH during power-on reset, this pin will be configured as 3VMREF# output. When Mode input is sampled LOW during power-on reset, this pin will be configured as PCI_STP# input. 3VMREF# is a 3.3V output running at half the frequency of the CPU output clock. 3VMREF# is 180 degree out of phase with respect to 3VMREF. PCI_STP# is a 3.3V LVTTTL-compatible input that disables PCI0:6 outputs.
3V66_0:3	31, 30, 28, 27	O	66-MHz Clock Outputs: 3.3V fixed 66-MHz clock.
PCI_F0/FS2	6	I/O	Free-running PCI Output 0/Frequency Select 2: 3.3V free-running PCI output. This pin also serves as a power-on strap option to determine device operating frequency as described in the Frequency Selection Table.
PCI_F1/FS3	7	I/O	Free-running PCI Output 1/Frequency Select 3: 3.3V free-running PCI output. This pin also serves as a power-on strap option to determine device operating frequency as described in the Frequency Selection Table.

Pin Definitions(continued)

Pin Name	Pin No.	Pin Type	Pin Description
PCI_F2/Mode	8	I/O	Free-running PCI Output 2/Mode Selection: 3.3V free-running PCI output. This pin also serves as a power-on strap option to determine the functions of 3VMREF/CPU_STP# and 3VMREF#/PCI_STP#. When Mode input is sampled HIGH during power-on reset, 3VMREF/CPU_STP# and 3VMREF#/PCI_STP# will be configured as 3VMREF and 3VMREF# output, respectively. When Mode input is sampled LOW during power-on reset, 3VMREF/CPU_STP# and 3VMREF#/PCI_STP# will be configured as CPU_STP# and PCI_STP# input, respectively.
PCI0/FS4	10	I/O	PCI Output 0/Frequency Select 4: 3.3V PCI output. This pin also serves as a power-on strap option to determine device operating frequency as described in the Frequency Selection Table.
PCI1:6	11, 12, 14, 15, 16, 17	O	PCI Clock Output 1 to 6: 3.3V PCI clock outputs.
48MHz/FS0	22	I/O	48MHz Output/Frequency Select 0: 3.3V fixed 48-MHz, non-spread spectrum output. This pin also serves as a power-on strap option to determine device operating frequency as described in <i>Table 4</i> . This output will be used as the reference clock for USB host controller in Intel 845 (Brookdale) platforms. For Intel Brookdale - G platforms, this output will be used as the VCH reference clock.
24_48MHz/FS1	23	I/O	24- or 48-MHz Output/Frequency Select 1: 3.3V fixed 24-MHz or 48-MHz non-spread spectrum output. This pin also serves as a power-on strap option to determine device operating frequency as described in <i>Table 4</i> . This output will be used as the reference clock for SIO devices in Intel 845 (Brookdale) platforms. For Intel Brookdale - G platforms, this output will be used as the reference clock for both USB host controller and SIO devices. We recommend system designer to configure this output as 48 MHz and "HIGH Drive" by setting Byte [5], Bit [0] and Byte [9], Bit [7], respectively.
PWR_DWN#	42	I	Power Down Control: 3.3V LVTTTL-compatible input that places the device in power down mode when held LOW.
SCLK	26	I	SMBus Clock Input: Clock pin for serial interface.
SDATA	25	I/O	SMBus Data Input: Data pin for serial interface.
RST#	20	O (open-drain)	System Reset Output: Open-drain system reset output.
IREF	35	I	Current Reference for CPU Output: A precision resistor is attached to this pin, which is connected to the internal current reference.
VTT_PWRGD#	19	I	Powergood from Voltage Regulator Module (VRM): 3.3V LVTTTL input. VTT_PWRGD# is a level sensitive strobe used to determine when FS0:4, MODE and MULTSEL0:1 inputs are valid and OK to be sampled (Active LOW). Once VTT_PWRGD# is sampled LOW, the status of this input will be ignored.
VDD_REF, VDD_PCI, VDD_48MHz, VDD_3V66, VDD_CPU VDD_MREF	2, 9, 18, 24, 32, 39, 46	P	3.3V Power Connection: Power supply for CPU outputs buffers, 3V66 output buffers, PCI output buffers, reference output buffers and 48-MHz output buffers. Connect to 3.3V.



Pin Definitions(continued)

Pin Name	Pin No.	Pin Type	Pin Description
GND_PCI, GND_48MHz, GND_3V66, GND_CPU, GND_MREF, GND_REF,	5, 13, 21, 29, 36, 43, 47	G	Ground Connection: Connect all ground pins to the common system ground plane.
VDD_CORE	34	P	3.3V Analog Power Connection: Power supply for core logic, PLL circuitry. Connect to 3.3V.
GND_CORE	33	G	Analog Ground Connection: Ground for core logic, PLL circuitry.



Swing Select Functions

MULTSEL1	MULTSEL0	Board Target Trace/Term Z	Reference R, IREF = V _{DD} /(3*Rr)	Output Current	V _{OH} @ Z
0	0	50Ω	Rr = 221 1%, IREF = 5.00 mA	I_{OH} = 4*IREF	1.0V @ 50
0	0	60Ω	Rr = 221 1%, IREF = 5.00 mA	I _{OH} = 4*IREF	1.2V @ 60
0	1	50Ω	Rr = 221 1%, IREF = 5.00 mA	I _{OH} = 5*IREF	1.25V @ 50
0	1	60Ω	Rr = 221 1%, IREF = 5.00 mA	I _{OH} = 5*IREF	1.5V @ 60
1	0	50Ω	Rr = 221 1%, IREF = 5.00 mA	I _{OH} = 6*IREF	1.5V @ 50
1	0	60Ω	Rr = 221 1%, IREF = 5.00 mA	I _{OH} = 6*IREF	1.8V @ 60
1	1	50Ω	Rr = 221 1%, IREF = 5.00 mA	I _{OH} = 7*IREF	1.75V @ 50
1	1	60Ω	Rr = 221 1%, IREF = 5.00 mA	I _{OH} = 7*IREF	2.1V @ 60
0	0	50Ω	Rr = 475 1%, IREF = 2.32 mA	I _{OH} = 4*IREF	0.47V @ 50
0	0	60Ω	Rr = 475 1%, IREF = 2.32 mA	I _{OH} = 4*IREF	0.56V @ 60
0	1	50Ω	Rr = 475 1%, IREF = 2.32 mA	I _{OH} = 5*IREF	0.58V @ 50
0	1	60Ω	Rr = 475 1%, IREF = 2.32 mA	I_{OH} = 5*IREF	0.7V @ 60
1	0	50Ω	Rr = 475 1%, IREF = 2.32 mA	I_{OH} = 6*IREF	0.7V @ 50
1	0	60Ω	Rr = 475 1%, IREF = 2.32 mA	I _{OH} = 6*IREF	0.84V @ 60
1	1	50Ω	Rr = 475 1%, IREF = 2.32 mA	I _{OH} = 7*IREF	0.81V @ 50
1	1	60Ω	Rr = 475 1%, IREF = 2.32 mA	I_{OH} = 7*IREF	0.97V @ 60

Serial Data Interface

To enhance the flexibility and function of the clock synthesizer, a two-signal serial interface is provided. Through the Serial Data Interface, various device functions such as individual clock output buffers, etc., can be individually enabled or disabled.

The registers associated with the Serial Data Interface initialize to their default setting upon power-up, and therefore use of this interface is optional. Clock device register changes are normally made upon system initialization, if any are required. The interface can also be used during system operation for power management functions.

Data Protocol

The clock driver serial protocol accepts byte write, byte read, block write, and block read operation from the controller. For block write/read operation, the bytes must be accessed in sequential order from lowest to highest byte (most significant bit first) with the ability to stop after any complete byte has been transferred. For byte write and byte read operations, the system controller can access individual indexed bytes. The offset of the indexed byte is encoded in the command code, as described in *Table 1*.

The block write and block read protocol is outlined in *Table 2* while *Table 2* outlines the corresponding byte write and byte read protocol.

The slave receiver address is 11010010 (D2h).

Table 1. Command Code Definition

Bit	Descriptions
7	0 = Block read or block write operation 1 = Byte read or byte write operation
6:0	Byte offset for byte read or byte write operation. For block read or block write operations, these bits should be '0000000'.

Table 2. Block Read and Block Write Protocol

Block Write Protocol		Block Read Protocol	
Bit	Description	Bit	Description
1	Start	1	Start
2:8	Slave address – 7 bits	2:8	Slave address – 7 bits
9	Write	9	Write
10	Acknowledge from slave	10	Acknowledge from slave
11:18	Command Code – 8 bits '00000000' stands for block operation	11:18	Command Code – 8 bits '00000000' stands for block operation
19	Acknowledge from slave	19	Acknowledge from slave
20:27	Byte Count – 8 bits	20	Repeat start
28	Acknowledge from slave	21:27	Slave address – 7 bits
29:36	Data byte 0 – 8 bits	28	Read
37	Acknowledge from slave	29	Acknowledge from slave
38:45	Data byte 1 – 8 bits	30:37	Byte count from slave – 8 bits
46	Acknowledge from slave	38	Acknowledge
...	Data Byte N/Slave Acknowledge...	39:46	Data byte from slave – 8 bits
...	Data Byte N – 8 bits	47	Acknowledge
...	Acknowledge from slave	48:55	Data byte from slave – 8 bits
...	Stop	56	Acknowledge
		...	Data bytes from slave/Acknowledge
		...	Data byte N from slave – 8 bits
		...	Not acknowledge
		...	Stop



Table 3. Byte Read and Byte Write Protocol

Byte Write Protocol		Byte Read Protocol	
Bit	Description	Bit	Description
1	Start	1	Start
2:8	Slave address – 7 bits	2:8	Slave address – 7 bits
9	Write	9	Write
10	Acknowledge from slave	10	Acknowledge from slave
11:18	Command Code – 8 bits '1xxxxxx' stands for byte operation bit[6:0] of the command code represents the offset of the byte to be accessed	11:18	Command Code – 8 bits '1xxxxxx' stands for byte operation bit[6:0] of the command code represents the offset of the byte to be accessed
19	Acknowledge from slave	19	Acknowledge from slave
20:27	Data byte – 8 bits	20	Repeat start
28	Acknowledge from slave	21:27	Slave address – 7 bits
29	Stop	28	Read
		29	Acknowledge from slave
		30:37	Data byte from slave – 8 bits
		38	Not acknowledge
		39	Stop

Data Byte Configuration Map

Data Byte 0

Bit	Pin#	Name	Description	Power-On Default
Bit 7	--	Spread Select2	'000' = OFF	0
Bit 6	--	Spread Select1	'001' = Reserved	0
Bit 5	--	Spread Select0	'010' = Reserved '011' = Reserved '100' = ± 0.25% '101' = - 0.5% '110' = ±0.5% '111' = ±0.38%	0
Bit 4	--	SEL4	SW Frequency selection bits. See <i>Table 4</i> .	0
Bit 3	--	SEL3		0
Bit 2	--	SEL2		0
Bit 1	--	SEL1		0
Bit 0	--	SEL0		0

Data Byte 1

Bit	Pin#	Name	Description	Power-On Default
Bit 7	38, 37	CPU1, CPU1#	(Active/Inactive)	1
Bit 6	41, 40	CPU0, CPU0#	(Active/Inactive)	1
Bit 5	22	48MHz	(Active/Inactive)	1
Bit 4	23	24_48MHz	(Active/Inactive)	1
Bit 3	27	3V66_3	(Active/Inactive)	1
Bit 2	28	3V66_2	(Active/Inactive)	1
Bit 1	30	3V66_1	(Active/Inactive)	1
Bit 0	31	3V66_0	(Active/Inactive)	1



Data Byte 2

Bit	Pin#	Name	Pin Description	Power-On Default
Bit 7	--	Reserved	Reserved	0
Bit 6	17	PCI6	(Active/Inactive)	1
Bit 5	16	PCI5	(Active/Inactive)	1
Bit 4	15	PCI4	(Active/Inactive)	1
Bit 3	14	PCI3	(Active/Inactive)	1
Bit 2	12	PCI2	(Active/Inactive)	1
Bit 1	11	PCI1	(Active/Inactive)	1
Bit 0	10	PCI0	(Active/Inactive)	1

Data Byte 3

Bit	Pin#	Name	Pin Description	Power-On Default
Bit 7	8	PCI_F2	(Active/Inactive)	1
Bit 6	7	PCI_F1	(Active/Inactive)	1
Bit 5	6	PCI_F0	(Active/Inactive)	1
Bit 4	--	Reserved	Reserved	0
Bit 3	44, 45	3VMREF#, 3VMREF	(Active/Inactive)	1
Bit 2	--	Reserved	Reserved	0
Bit 1	1	REF1	(Active/Inactive)	1
Bit 0	48	REF0	(Active/Inactive)	1

Data Byte 4

Bit	Pin#	Name	Pin Description	Power-On Default
Bit 7	--	MULTSEL_Override	This bit control the selection of IREF multiplier. 0 = HW control; IREF multiplier is determined by MULT-SEL[0:1] input pins 1 = SW control; IREF multiplier is determined by Byte[4], Bit[5:6].	0
Bit 6	--	SW_MULTSEL1	IREF multiplier 00 = Ioh is 4 x IREF 01 = Ioh is 5 x IREF 10 = Ioh is 6 x IREF 11 = Ioh is 7 x IREF	0
Bit 5	--	SW_MULTSEL0		0
Bit 4	--	Reserved	Reserved	Reserved
Bit 3	--	Reserved	Reserved	Reserved
Bit 2	--	Reserved	Reserved	Reserved
Bit 1	--	CPU1 Stop Control	0 = Not free running 1 = Free running; not affected by CPU_STOP#	0
Bit 0	--	CPU0 Stop Control	0 = Not free running 1 = Free running; not affected by CPU_STOP#	0



Data Byte 5

Bit	Pin#	Name	Pin Description	Power-On Default
Bit 7	10	Latched FS4 input	Latched FS[4:0] inputs. These bits are read only.	X
Bit 6	7	Latched FS3 input		X
Bit 5	6	Latched FS2 input		X
Bit 4	23	Latched FS1 input		X
Bit 3	22	Latched FS0 input		X
Bit 2	--	FS_Override	0 = Select operating frequency by FS[4:0] input pins 1 = Select operating frequency by SEL[4:0] settings	0
Bit 1	--	Reserved	Reserved	0
Bit 0	23	SEL 48MHZ	0 = 24 MHz 1 = 48 MHz	0

Data Byte 6

Bit	Pin#	Name	Pin Description	Power-On Default
Bit 7		Revision_ID3	Revision ID bit[3]	0
Bit 6		Revision_ID2	Revision ID bit[2]	0
Bit 5		Revision_ID1	Revision ID bit[1]	0
Bit 4		Revision_ID0	Revision ID bit[0]	0
Bit 3		Vendor_ID3	Bit[3] of Cypress Semiconductor's Vendor ID. This bit is read only.	1
Bit 2		Vendor_ID2	Bit[2] of Cypress Semiconductor's Vendor ID. This bit is read only.	0
Bit 1		Vendor_ID1	Bit[1] of Cypress Semiconductor's Vendor ID. This bit is read only.	0
Bit 0		Vendor_ID0	Bit[0] of Cypress Semiconductor's Vendor ID. This bit is read only.	0

Data Byte 7

Bit	Pin#	Name	Pin Description	Power-On Default
Bit 7	--	Reserved	Reserved	0
Bit 6	--	Reserved	Reserved	0
Bit 5	--	Reserved	Reserved	0
Bit 4	--	Reserved	Reserved	0
Bit 3	--	Reserved	Reserved	0
Bit 2	--	Reserved	Reserved	0
Bit 1	--	Reserved	Reserved	0
Bit 0	--	Reserved	Reserved	0



Data Byte 8

Bit	Pin#	Name	Pin Description	Power-On Default
Bit 7	--	Reserved	Reserved	0
Bit 6	--	Reserved	Reserved	0
Bit 5	--	WD_TIMER4	These bits store the time-out value of the Watchdog Timer. The scale of the timer is determine by the prescaler. The timer can support a value of 150 ms to 4.8 sec when the prescalar is set to 150 ms. If the prescalar is set to 2.5 sec, it can support a value from 2.5 sec. to 80 sec. When the Watchdog Timer reaches "0," it will set the WD_TO_STATUS bit and generate Reset if RST_EN_WD is enabled.	1
Bit 4	--	WD_TIMER3		1
Bit 3	--	WD_TIMER2		1
Bit 2	--	WD_TIMER1		1
Bit 1	--	WD_TIMER0		1
Bit 0	--	WD_PRE_SCALER	0 = 150 ms 1 = 2.5 sec	0

Data Byte 9

Bit	Pin#	Name	Pin Description	Power-On Default
Bit 7	--	48MHz_DRV	48MHz & 24_48MHz clock output drive strength 0 = Normal 1 = High Drive (Recommend to set to high drive if this output is being used to drive both USB and SIO devices in Intel® Brookdale - G platforms)	0
Bit 6	--	PCI_DRV	PCI clock output drive strength 0 = Normal 1 = High Drive	0
Bit 5	--	3V66_DRV	3V66 clock output drive strength 0 = Normal 1 = High Drive	0
Bit 4	--	RST_EN_WD	This bit will enable the generation of a Reset pulse when a Watchdog Timer time-out occurs. 0 = Disabled 1 = Enabled	0
Bit 3	--	RST_EN_FC	This bit will enable the generation of a Reset pulse after a frequency change occurs. 0 = Disabled 1 = Enabled	0
Bit 2	--	WD_TO_STATUS	Watchdog Timer Time-out Status bit 0 = No time-out occurs (READ); Ignore (WRITE) 1 = Time-out occurred (READ); Clear WD_TO_STATUS (WRITE)	0
Bit 1	--	WD_EN	0 = Stop and reload Watchdog Timer 1 = Enable Watchdog Timer. It will start counting down after a frequency change occurs. Note: CY28324 will generate system reset, reload a recovery frequency, and lock itself into a recovery frequency mode after a Watchdog Timer time-out occurs. Under recovery frequency mode, CY28324 will not respond to any attempt to change output frequency via the SMBus control bytes. System software can unlock CY28324 from its recovery frequency mode by clearing the WD_EN bit.	0
Bit 0	--	Reserved	Reserved	0



Data Byte 10

Bit	Pin#	Name	Pin Description	Power-On Default
Bit 7	10	CPU_Skew2	CPU skew control	0
Bit 6	7	CPU_Skew1	000 = Normal	0
Bit 5	6	CPU_Skew0	001 = -150 ps 010 = -300 ps 011 = -450 ps 100 = +150 ps 101 = +300 ps 110 = +450 ps 111 = +600 ps	0
Bit 4	23	Reserved	Reserved	0
Bit 3	22	PCI_Skew1	PCI skew control	0
Bit 2	--	PCI_Skew0	00 = Normal 01 = -500 ps 10 = Reserved 11 = +500 ps	0
Bit 1	--	3V66_Skew1	3v66 skew control	0
Bit 0	--	3V66_Skew0	00 = Normal 01 = -150 ps 10 = +150 ps 11 = +300 ps	0

Data Byte 11

Bit	Pin#	Name	Pin Description	Power-On Default
Bit 7	--	ROCV_FREQ_N7	If ROCV_FREQ_SEL is set, the values programmed in ROCV_FREQ_N[7:0] and ROCV_FREQ_M[6:0] will be used to determine the recovery CPU output frequency when a Watchdog Timer time-out occurs. The setting of FS_Override bit determines the frequency ratio for CPU and other output clocks. When FS_Override bit is cleared, the same frequency ratio stated in the Latched FS[4:0] register will be used. When it is set, the frequency ratio stated in the SEL[4:0] register will be used.	0
Bit 6	--	ROCV_FREQ_N6		0
Bit 5	--	ROCV_FREQ_N5		0
Bit 4	--	ROCV_FREQ_N4		0
Bit 3	--	ROCV_FREQ_N3		0
Bit 2	--	ROCV_FREQ_N2		0
Bit 1	--	ROCV_FREQ_N1		0
Bit 0	--	ROCV_FREQ_N0		0

Data Byte 12

Bit	Pin#	Name	Pin Description	Power-On Default
Bit 7	--	ROCV_FREQ_SEL	ROCV_FREQ_SEL determines the source of the recover frequency when a Watchdog Timer time-out occurs. The clock generator will automatically switch to the recovery CPU frequency based on the selection on ROCV_FREQ_SEL. 0 = From latched FS[4:0] 1 = From the settings of ROCV_FREQ_N[7:0] & ROCV_FREQ_M[6:0]	0



Data Byte 12 (continued)

Bit	Pin#	Name	Pin Description	Power-On Default
Bit 6	--	ROCV_FREQ_M6	If ROCV_FREQ_SEL is set, the values programmed in ROCV_FREQ_N[7:0] and ROCV_FREQ_M[6:0] will be used to determine the recovery CPU output frequency when a Watchdog Timer time-out occurs. The setting of FS_Override bit determines the frequency ratio for CPU and other output clocks. When FS_Override bit is cleared, the same frequency ratio stated in the Latched FS[4:0] register will be used. When it is set, the frequency ratio stated in the SEL[4:0] register will be used.	0
Bit 5	--	ROCV_FREQ_M5		0
Bit 4	--	ROCV_FREQ_M4		0
Bit 3	--	ROCV_FREQ_M3		0
Bit 2	--	ROCV_FREQ_M2		0
Bit 1	--	ROCV_FREQ_M1		0
Bit 0	--	ROCV_FREQ_M0		0

Data Byte 13

Bit	Pin#	Name	Pin Description	Power-On Default
Bit 7	--	CPU_FSEL_N7	If Prog_Freq_EN is set, the values programmed in CPU_FSEL_N[7:0] and CPU_FSEL_M[6:0] will be used to determine the CPU output frequency. The new frequency will start to load whenever CPU_FSELM[6:0] is updated. The setting of FS_Override bit determines the frequency ratio for CPU and other output clocks. When it is cleared, the same frequency ratio stated in the Latched FS[4:0] register will be used. When it is set, the frequency ratio stated in the SEL[4:0] register will be used.	0
Bit 6	--	CPU_FSEL_N6		0
Bit 5	--	CPU_FSEL_N5		0
Bit 4	--	CPU_FSEL_N4		0
Bit 3	--	CPU_FSEL_N3		0
Bit 2	--	CPU_FSEL_N2		0
Bit 1	--	CPU_FSEL_N1		0
Bit 0	--	CPU_FSEL_N0		0

Data Byte 14

Bit	Pin#	Name	Pin Description	Power-On Default
Bit 7	--	Pro_Freq_EN	Programmable output frequencies enabled 0 = Disabled 1 = Enabled	0
Bit 6	--	CPU_FSEL_M6	If Prog_Freq_EN is set, the values programmed in CPU_FSEL_N[7:0] and CPU_FSEL_M[6:0] will be used to determine the CPU output frequency. The new frequency will start to load whenever CPU_FSELM[6:0] is updated.	0
Bit 5	--	CPU_FSEL_M5		0
Bit 4	--	CPU_FSEL_M4		0
Bit 3	--	CPU_FSEL_M3	The setting of FS_Override bit determines the frequency ratio for CPU and other output clocks. When it is cleared, the same frequency ratio stated in the Latched FS[4:0] register will be used. When it is set, the frequency ratio stated in the SEL[4:0] register will be used.	0
Bit 2	--	CPU_FSEL_M2		0
Bit 1	--	CPU_FSEL_M1		0
Bit 0	--	CPU_FSEL_M0		0

Data Byte 15

Bit	Pin#	Name	Pin Description	Power-On Default
Bit 7	--	Reserved	Reserved	0
Bit 6	--	Reserved	Reserved	0
Bit 5	--	Reserved	Reserved	0
Bit 4	--	Reserved	Reserved	0



Data Byte 15 (continued)

Bit	Pin#	Name	Pin Description	Power-On Default
Bit 3	--	Reserved	Reserved	0
Bit 2	--	Reserved	Reserved	0
Bit 1	--	Vendor Test Mode	Reserved. Write with "1"	1
Bit 0	--	Vendor Test Mode	Reserved. Write with "1"	1

Data Byte 16

Bit	Pin#	Name	Pin Description	Power-On Default
Bit 7	--	Reserved	Reserved	0
Bit 6	--	Reserved	Reserved	0
Bit 5	--	Reserved	Reserved	0
Bit 4	--	Reserved	Reserved	0
Bit 3	--	Reserved	Reserved	0
Bit 2	--	Reserved	Reserved	0
Bit 1	--	Reserved	Reserved	0
Bit 0	--	Reserved	Reserved	0

Data Byte 17

Bit	Pin#	Name	Pin Description	Power-On Default
Bit 7	--	Reserved	Reserved	0
Bit 6	--	Reserved	Reserved	0
Bit 5	--	Reserved	Reserved	0
Bit 4	--	Reserved	Reserved	0
Bit 3	--	Reserved	Reserved	0
Bit 2	--	Reserved	Reserved	0
Bit 1	--	Reserved	Reserved	0
Bit 0	--	Reserved	Reserved	0



Table 4. Frequency Selection Table

Input Conditions					Output Frequency			PLL Gear Constants (G)
FS4 SEL4	FS3 SEL3	FS2 SEL2	FS1 SEL1	FS0 SEL0	CPU	3V66	PCI	
0	0	0	0	0	102.0	68.0	34.0	48.00741
0	0	0	0	1	105.0	70.0	35.0	48.00741
0	0	0	1	0	108.0	72.0	36.0	48.00741
0	0	0	1	1	111.0	74.0	37.0	48.00741
0	0	1	0	0	114.0	76.0	38.0	48.00741
0	0	1	0	1	117.0	78.0	39.0	48.00741
0	0	1	1	0	120.0	80.0	40.0	48.00741
0	0	1	1	1	123.0	82.0	41.0	48.00741
0	1	0	0	0	126.0	63.0	31.5	48.00741
0	1	0	0	1	130.0	65.0	32.5	48.00741
0	1	0	1	0	136.0	68.0	34.0	48.00741
0	1	0	1	1	140.0	70.0	35.0	48.00741
0	1	1	0	0	144.0	72.0	36.0	48.00741
0	1	1	0	1	148.0	74.0	37.0	48.00741
0	1	1	1	0	152.0	76.0	38.0	48.00741
0	1	1	1	1	156.0	78.0	39.0	48.00741
1	0	0	0	0	160.0	80.0	40.0	48.00741
1	0	0	0	1	164.0	82.0	41.0	48.00741
1	0	0	1	0	166.6	66.6	33.3	48.00741
1	0	0	1	1	170.0	68.0	34.0	48.00741
1	0	1	0	0	175.0	70.0	35.0	48.00741
1	0	1	0	1	180.0	72.0	36.0	48.00741
1	0	1	1	0	185.0	74.0	37.0	48.00741
1	0	1	1	1	190.0	76.0	38.0	48.00741
1	1	0	0	0	66.8	66.8	33.4	48.00741
1	1	0	0	1	100.2	66.8	33.4	48.00741
1	1	0	1	0	133.6	66.8	33.4	48.00741
1	1	0	1	1	200.4	66.8	33.4	48.00741
1	1	1	0	0	66.6	66.6	33.3	48.00741
1	1	1	0	1	100.0	66.6	33.3	48.00741
1	1	1	1	0	200.0	66.6	33.3	48.00741
1	1	1	1	1	133.3	66.6	33.3	48.00741



Programmable Output Frequency, Watchdog Timer and Recovery Output Frequency Functional Description

The Programmable Output Frequency feature allows users to generate any CPU output frequency in the range of 50 MHz to 248 MHz. Cypress offers the most dynamic and the simplest programming interface for system developers to utilize this feature in their platforms.

The Watchdog Timer and Recovery Output Frequency features allow users to implement a recovery mechanism when the system hangs or getting unstable. System BIOS or other control software can enable the Watchdog Timer before they attempt to make a frequency change. If the system hangs and a Watchdog Timer time-out occurs, a system reset will be generated and a recovery frequency will be activated.

All the related registers are summarized in the following table.

Register Summary	
Name	Description
Pro_Freq_EN	<p>Programmable output frequencies enabled</p> <p>0 = Disabled (Default)</p> <p>1 = Enabled</p> <p>When it is disabled, the operating output frequency will be determined by either the latched value of FS[4:0] inputs or the programmed value of SEL[4:0]. If the FS_Override bit is clear, latched FS[4:0] inputs will be used. If FS_Override bit is set, programmed value of SEL[4:0] will be used.</p> <p>When it is enabled, the CPU output frequency will be determined by the programmed value of CPUFSEL_N, CPUFSEL_M and the PLL Gear Constant. The program value of FS_Override, SEL[4:0] or the latched value of FS[4:0] will determine the PLL Gear Constant and the frequency ratio between CPU and other frequency outputs.</p>
FS_Override	<p>When Pro_Freq_EN is cleared or disabled,</p> <p>0 = Select operating frequency by FS input pins (default)</p> <p>1 = Select operating frequency by SEL bits in SMBus control bytes</p> <p>When Pro_Freq_EN is set or enabled,</p> <p>0 = Frequency output ratio between CPU and other frequency groups and the PLL Gear Constant are based on the latched value of FS input pins (default)</p> <p>1 = Frequency output ratio between CPU and other frequency groups and the PLL Gear Constant are based on the programmed value of SEL bits in SMBus control bytes</p>
CPU_FSEL_N, CPU_FSEL_M	<p>When Prog_Freq_EN is set or enabled, the values programmed in CPU_FSEL_N[7:0] and CPU_FSEL_M[6:0] determines the CPU output frequency. The new frequency will start to load whenever there is an update to either CPU_FSEL_N[7:0] or CPU_FSEL_M[6:0]. Therefore, it is recommended to use Word or Block write to update both registers within the same SMBus bus operation.</p> <p>The setting of FS_Override bit determines the frequency ratio for CPU, AGP and PIC. When FS_Override is cleared or disabled, the frequency ratio follows the latched value of the FS input pins. When FS_Override is set or enabled, the frequency ratio follows the programmed value of SEL bits in SMBus control bytes.</p>
ROCV_FREQ_SEL	<p>ROCV_FREQ_SEL determines the source of the recover frequency when a Watchdog timer time-out occurs. The clock generator will automatically switch to the recovery CPU frequency based on the selection on ROCV_FREQ_SEL.</p> <p>0 = From latched FS[4:0]</p> <p>1 = From the settings of ROCV_FREQ_N[7:0] & ROCV_FREQ_M[6:0]</p>
ROCV_FREQ_N[7:0], ROCV_FREQ_M[6:0]	<p>When ROCV_FREQ_SEL is set, the values programmed in ROCV_FREQ_N[7:0] and ROCV_FREQ_M[6:0] will be used to determine the recovery CPU output frequency when a Watchdog Timer time-out occurs</p> <p>The setting of FS_Override bit determines the frequency ratio for CPU, AGP and PIC. When it is cleared, the same frequency ratio stated in the Latched FS[4:0] register will be used. When it is set, the frequency ratio stated in the SEL[4:0] register will be used.</p> <p>The new frequency will start to load whenever there is an update to either ROCV_FREQ_N[7:0] and ROCV_FREQ_M[6:0]. Therefore, it is recommended to use Word or Block write to update both registers within the same SMBus bus operation.</p>
WD_EN	<p>0 = Stop and re-load Watchdog Timer</p> <p>1 = Enable Watchdog Timer. It will start counting down after a frequency change occurs</p>

Register Summary(continued)	
Name	Description
WD_TO_STATUS	Watchdog Timer Time-out Status bit 0 = No time-out occurs (READ); Ignore (WRITE) 1 = Time-out occurred (READ); Clear WD_TO_STATUS (WRITE)
WD_TIMER[4:0]	These bits store the time-out value of the Watchdog Timer. The scale of the timer is determine by the prescaler. The timer can support a value of 150 ms to 4.8 sec when the prescaler is set to 150 ms. If the prescaler is set to 2.5 sec, it can support a value from 2.5 sec to 80 sec. When the Watchdog Timer reaches "0," it will set the WD_TO_STATUS bit.
WD_PRE_SCALER	0 = 150 ms 1 = 2.5 sec
RST_EN_WD	This bit will enable the generation of a Reset pulse when a Watchdog timer time-out occurs. 0 = Disabled 1 = Enabled
RST_EN_FC	This bit will enable the generation of a Reset pulse after a frequency change occurs. 0 = Disabled 1 = Enabled

Program the CPU output frequency

When the programmable output frequency feature is enabled (Pro_Freq_EN bit is set), the CPU output frequency is determined by the following equation:

$$F_{cpu} = G * (N+3)/(M+3)$$

"N" and "M" are the values programmed in Programmable Frequency Select N-Value Register and M-Value Register, respectively.

"G" stands for the PLL Gear Constant, which is determined by the programmed value of FS[4:0] or SEL[4:0]. The value is listed in *Table 4*.

The ratio of (N + 3) and (M + 3) need to be greater than "1" [(N + 3)/(M + 3) > 1].

The following table lists set of N and M values for different frequency output ranges. This example use a fixed value for the M-Value Register and select the CPU output frequency by changing the value of the N-Value Register.

Table 5. Examples of N and M Value for Different CPU Frequency Range

Frequency Ranges	Gear Constants	Fixed Value for M-Value Register	Range of N-Value Register for Different CPU Frequency
50 MHz–129 MHz	48.00741	93	97–255
130 MHz–248 MHz	48.00741	45	127–245



Maximum Ratings

(Above which the useful life may be impaired. For user guidelines, not tested.)

Supply Voltage -0.5 to +7.0V
 Input Voltage -0.5V to $V_{DD} + 0.5$

Storage Temperature (Non-Condensing).... -65°C to +150°C
 Max. Soldering Temperature (10 sec) +260°C
 Junction Temperature +150°C
 Package Power Dissipation 1W
 Static Discharge Voltage
 (per MIL-STD-883, Method 3015) >2000V

Operating Conditions Over which Electrical Parameters are Guaranteed

Parameter	Description	Min.	Max.	Unit
$V_{DD_REF}, V_{DD_PCI}, V_{DD_CORE}, V_{DD_3V66}, V_{DD_48\ MHz}, V_{DD_CPU}$	3.3V Supply Voltages	3.135	3.465	V
T_A	Operating Temperature, Ambient	0	70	°C
C_{in}	Input Pin Capacitance		5	pF
C_{XTAL}	XTAL Pin Capacitance		22.5	pF
C_L	Max. Capacitive Load on 48 MHz, REF PCICLK, 3V66		20 30	pF
$f_{(REF)}$	Reference Frequency, Oscillator Nominal Value	14.318	14.318	MHz

Electrical Characteristics Over the Operating Range

Parameter	Description	Test Conditions	Min.	Max.	Unit
V_{IH}	High-level Input Voltage	Except Crystal Pads. Threshold voltage for crystal pads = $V_{DD}/2$	2.0		V
V_{IL}	Low-level Input Voltage	Except Crystal Pads		0.8	V
V_{OH}	High-level Output Voltage	48 MHz, REF, 3V66, 3VMREF $I_{OH} = -1\ mA$	2.4		V
		PCI $I_{OH} = -1\ mA$	2.4		V
V_{OL}	Low-level Output Voltage	48 MHz, REF, 3V66, 3VMREF $I_{OL} = 1\ mA$		0.4	V
		PCI $I_{OL} = 1\ mA$		0.55	V
I_{IH}	Input High Current	$0 \leq V_{IN} \leq V_{DD}$	-5	5	mA
I_{IL}	Input Low Current	$0 \leq V_{IN} \leq V_{DD}$	-5	5	mA
I_{OH}	High-level Output Current	CPU For $I_{OH} = 6 \cdot I_{Ref}$ Configuration Type X1, $V_{OH} = 0.65V$	12.9		mA
		Type X1, $V_{OH} = 0.74V$		14.9	
		REF, 48 MHz, 3VMREF Type 3, $V_{OH} = 1.00V$	-29		
		Type 3, $V_{OH} = 3.135V$		-23	
		3V66, 3VMREF, PCI Type 5, $V_{OH} = 1.00V$	-33		
		Type 5, $V_{OH} = 3.135V$		-33	
I_{OL}	Low-level Output Current	REF, 3VMREF, 48 MHz Type 3, $V_{OL} = 1.95V$	29		mA
		Type 3, $V_{OL} = 0.4V$		27	
		3V66, PCI, 3VMREF Type 5, $V_{OL} = 1.95\ V$	30		
		Type 5, $V_{OL} = 0.4V$		38	
I_{OZ}	Output Leakage Current	Three-state		10	mA
I_{DD3}	3.3V Power Supply Current	$V_{DD_CORE}/V_{DDQ3} = 3.465V, F_{CPU} = 133\ MHz$		250	mA
I_{DDP3}	3.3V Shutdown Current	$V_{DD_CORE}/V_{DDQ3} = 3.465V$		20	mA

Switching Characteristics^[2] Over the Operating Range

Parameter	Output	Description	Test Conditions	Min.	Max.	Unit
t_1	All	Output Duty Cycle ^[3]	$t_{1A}/(t_{1B})$	45	55	%
t_2	CPU	Rise Time	Measured at 20% to 80% of V_{oh}	175	700	ps
t_2	REF, 48 MHz	Rising Edge Rate	Between 0.4V and 2.4V	0.5	2.0	V/ns
t_2	PCI, 3V66, 3VMREF	Rising Edge Rate	Between 0.4V and 2.4V	1.0	4.0	V/ns
t_3	CPU	Fall Time	Measured at 80% to 20% of V_{oh}	175	700	ps
t_3	REF, 48 MHz	Falling Edge Rate	Between 2.4V and 0.4V	0.5	2.0	V/ns
t_3	PCI, 3V66, 3VMREF	Falling Edge Rate	Between 2.4V and 0.4V	1.0	4.0	V/ns
t_4	CPU	CPU-CPU Skew	Measured at Crossover		150	ps
t_5	3V66 [0:3]	3V66-3V66 Skew	Measured at 1.5V		500	ps
t_6	PCI	PCI-PCI Skew	Measured at 1.5V		500	ps
t_7	3V66, PCI	3V66-PCI Clock Skew	3V66 leads. Measured at 1.5V	1.5	3.5	ns
t_8	CPU	Cycle-Cycle Clock Jitter	Measured at Crossover $t_8 = t_{8A} - t_{8B}$ With all outputs running		200	ps
t_9	3V66, 3VMREF	Cycle-Cycle Clock Jitter	Measured at 1.5V $t_9 = t_{9A} - t_{9B}$		250	ps
t_9	48 MHz	Cycle-Cycle Clock Jitter	Measured at 1.5V $t_9 = t_{9A} - t_{9B}$		350	ps
t_9	PCI	Cycle-Cycle Clock Jitter	Measured at 1.5V $t_9 = t_{9A} - t_{9B}$		500	ps
t_9	REF	Cycle-Cycle Clock Jitter	Measured at 1.5V $t_9 = t_{9A} - t_{9B}$		1000	ps
	CPU, PCI	Settle Time	CPU and PCI clock stabilization from power-up		3	ms
	CPU	Rise/Fall Matching	Measured with test loads ^[4, 5]		20%	
	CPU	Overshoot	Measured with test loads ^[5]		$V_{oh} + 0.2$	V
	CPU	Undershoot	Measured with test loads ^[5]	-0.2		V
V_{oh}	CPU	High-level Output Voltage	Measured with test loads ^[5]	0.65	0.74	V
V_{ol}	CPU	Low-level Output Voltage	Measured with test loads ^[5]	0.0	0.05	V
$V_{crossover}$	CPU	Crossover Voltage	Measured with test loads ^[5]	45% of 0.65	55% of 0.74	V

Notes:

- All parameters specified with loaded outputs.
- Duty cycle is measured at 1.5V when $V_{DD} = 3.3V$. When $V_{DD} = 2.5V$, duty cycle is measured at 1.25V.
- Determined as a fraction of $2*(t_{RP} - t_{RN})/(t_{RP} + t_{RN})$ Where t_{RP} is a rising edge and t_{RN} is an intersecting falling edge.
- The test load is $R_S = 33.2\Omega$, $R_D = 49.9\Omega$ in test circuit.

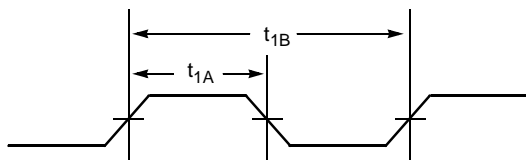
Switching Waveforms
Duty Cycle Timing (Single Ended Output)

Switching Waveforms (continued)

Duty Cycle Timing (CPU Differential Output)

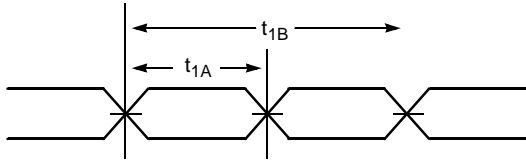

All Outputs Rise/Fall Time

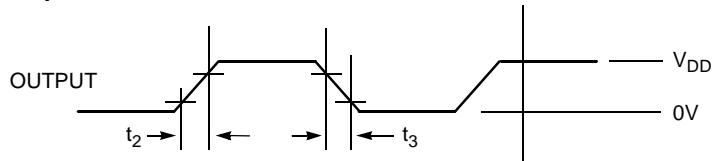

CPU-CPU Clock Skew

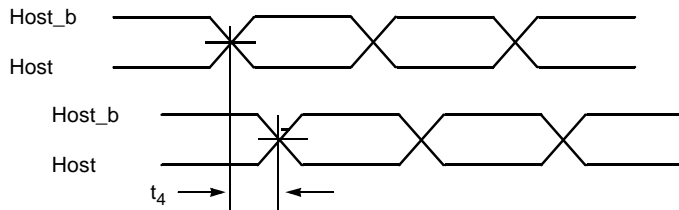

3V66-3V66 Clock Skew

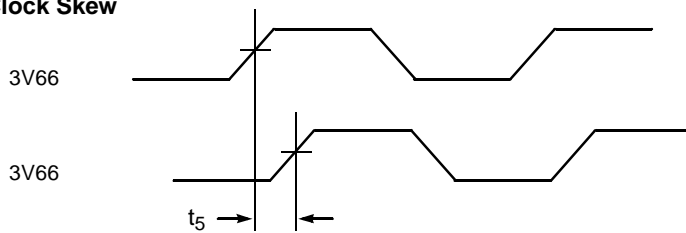

PCI-PCI Clock Skew

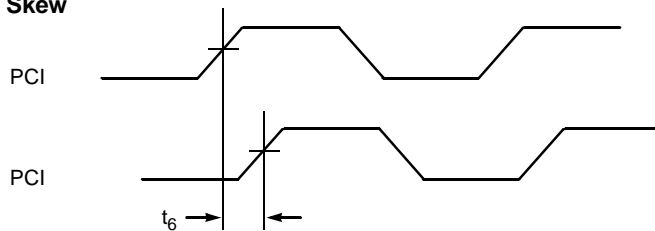

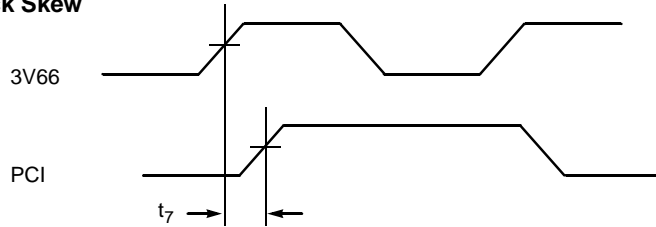
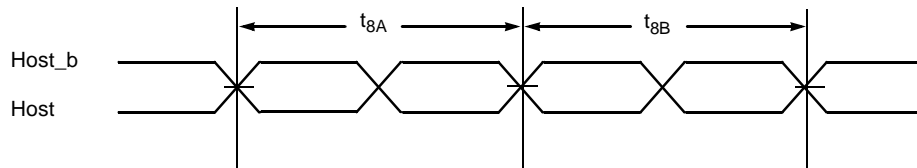
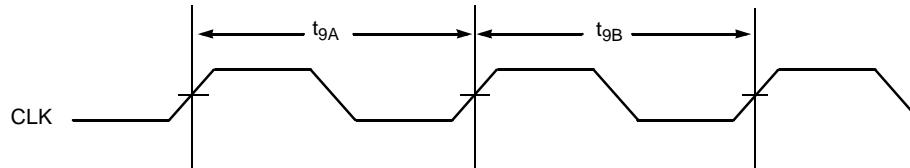
Switching Waveforms (continued)
3V66-PCI Clock Skew

CPU Clock Cycle-Cycle Jitter

Cycle-Cycle Clock Jitter

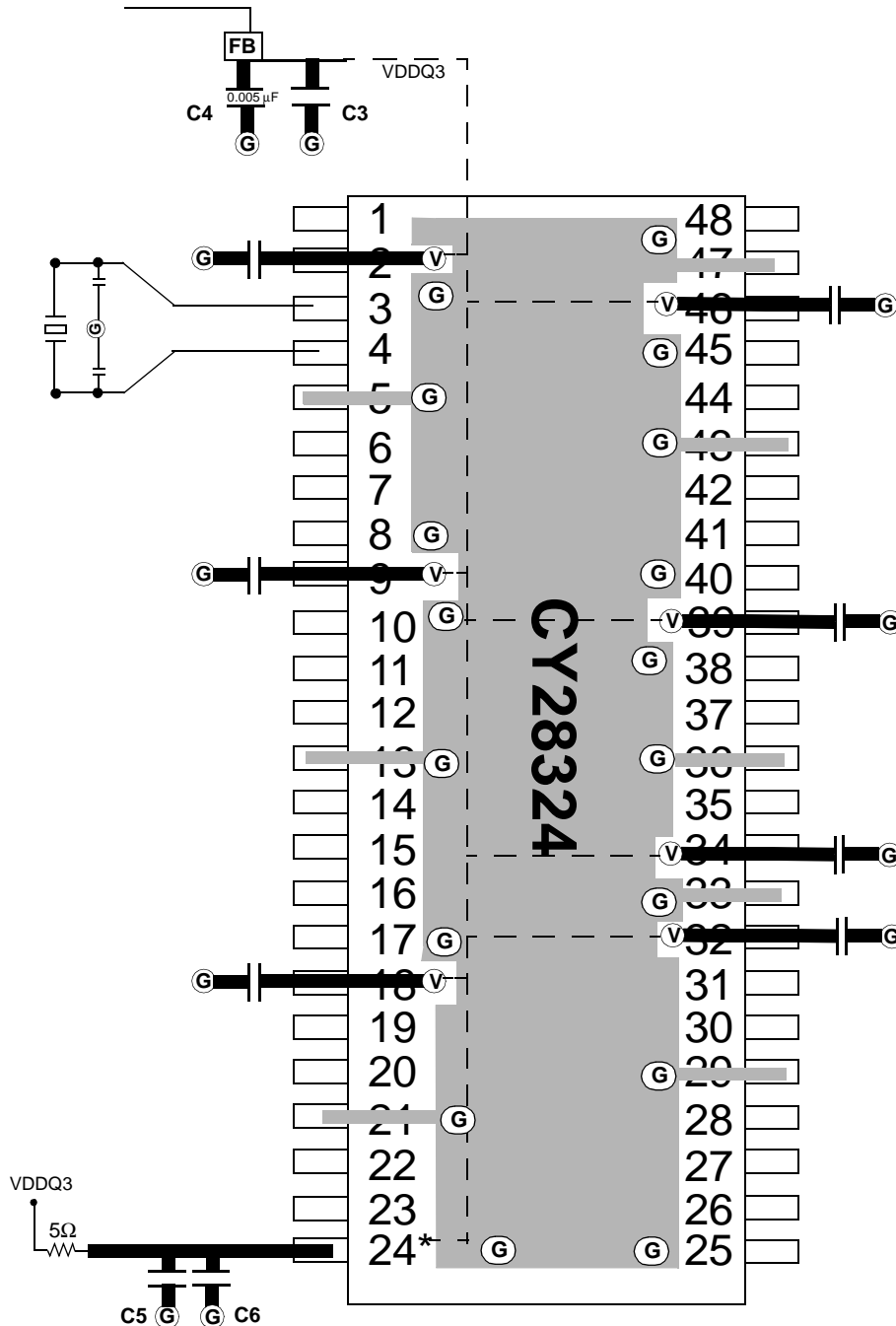
Ordering Information

Ordering Code	Package Name	Package Type	Operating Range
CY28324PVC	O48	48-pin Small Shrunken Outline Package (SSOP)	Commercial

Layout Example



FB = Dale ILB1206 - 300 (300Ω @ 100 MHz)

Ceramic Caps C3 = 10–22 μF C4 = 0.005 μF C5 = 10 μF C6 = 0.1 μF

Ⓞ = VIA to GND plane layer Ⓟ = VIA to respective supply plane layer

Note: Each supply plane or strip should have a ferrite bead and capacitors

All bypass caps = 0.1 μF ceramic

* For use with onboard video using 48 MHz for Dot Clock or connect to VDDQ3

Package Diagram

48-Lead Shrunk Small Outline Package O48

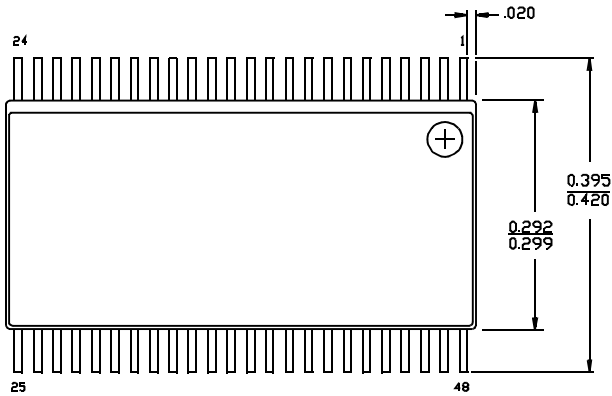

DIMENSIONS IN INCHES MIN.
MAX.

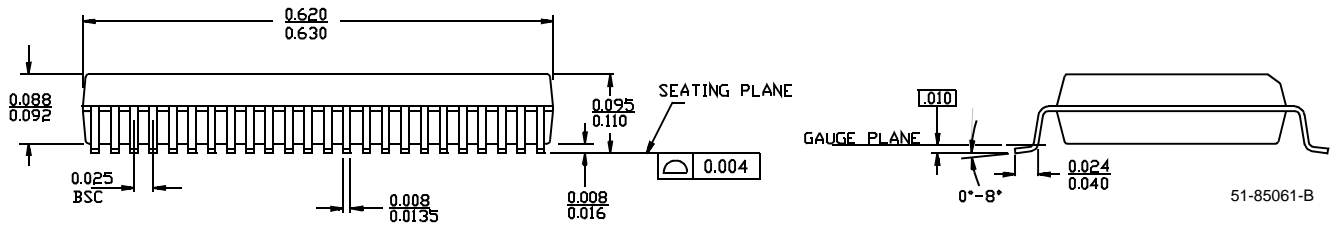



PRELIMINARY

CY28324

Document Title: CY28324 FTG For Intel® Pentium® 4 CPU and Chipsets				
Document Number: 38-07002				
REV.	ECN NO.	Issue Date	Orig. of Change	Description of Change
**	105839	03/30/01	IKA	New Spec.
*A	110865	11/15/01	IKA	Revised 2nd bullet on p.1: Intel 850, Brookdale (845) Added note on p.3 and p.9 regarding Brookdale platform