



CYPRESS

CY28342

High-performance SiS645/650 Pentium® 4 Clock Synthesizer

Features

- Supports Pentium® 4-type CPUs
- 3.3V power supply
- Eight copies of PCI clocks
- One 4-MHz USB clock
- Two copies of ZCLK clocks
- One 48-MHz/24-MHz programmable SIO clock
- Two differential CPU clock pairs
- SMBus support with read-back capabilities
- Spread Spectrum EMI reduction
- Dial-a-Frequency® features
- Dial-a-Ratio™ features
- Dial-a-dB® features
- 48-pin SSOP and TSSOP packages
- Watchdog Function

Block Diagram

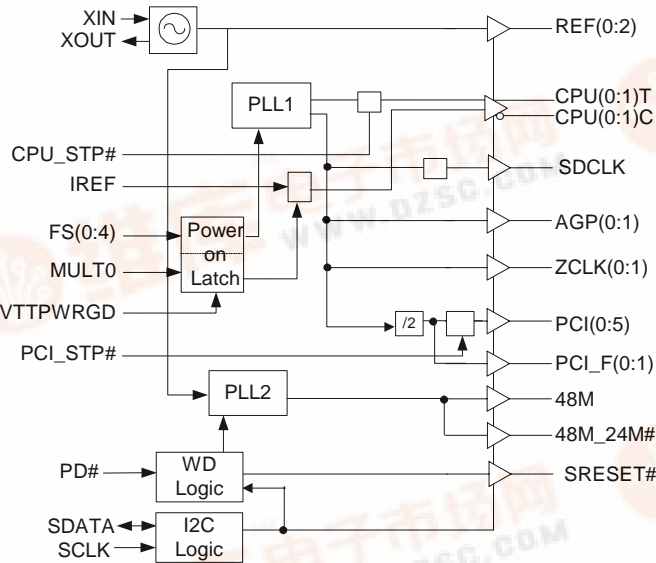

Pin Configuration^[1]

VDDR	1	48	VDDSD
**FS0/REF0	2	47	SDCLK
**FS1/REF1	3	46	VSSSD
**FS2/REF2	4	45	CPU_STP#
VSSR	5	44	CPU1T
XIN	6	43	CPU1C
XOUT	7	42	VDDC
VSSZ	8	41	VSSC
ZCLK0	9	40	CPU0T
ZCLK1	10	39	CPU0C
VDDZ	11	38	IREF
*SRESET#/PCI_STP#	12	37	VSSA
VDDP	13	36	VDDA
**FS3/PCI_F0	14	35	SQLK
**FS4/PCI_F1	15	34	SDATA
PCI0	16	33	PD#/VTTTPWRGD*
PCI1	17	32	VSSAGP
VSSP	18	31	AGP0
VDDP	19	30	AGP1
PCI2	20	29	VDDAGP
PCI3	21	28	VDD48M
PCI4	22	27	48M
PCI5	23	26	24_48M/MULT0*
VSSP	24	25	VSS48M

48 Pin SSOP and TSSOP

Note:

1. Pins marked with [*] have internal pull-up resistors. Pins marked with [**] have internal pull-down resistors.



Table 1. Frequency Table

FS(4:0)	CPU (MHz)	SDRAM (MHz)	ZCLK (MHz)	AGP (MHz)	PCI (MHz)	VCO (MHz)
00000	100.20	100.20	66.80	66.80	33.40	400.8
00001	133.45	133.45	66.73	66.73	33.365	533.8
00010	100.20	133.60	66.80	66.80	33.40	400.8
00011	133.45	100.09	66.73	66.73	33.365	400.4
00100	100.20	167.00	62.63	62.63	31.315	501.0
00101	133.33	166.66	66.67	66.67	33.335	666.7
00110	100.20	150.30	66.80	66.80	33.40	601.2
00111	133.33	66.67	66.67	66.67	33.335	533.3
01000	100.20	120.24	66.80	66.80	33.40	601.2
01001	145.00	145.00	64.44	64.44	32.22	580.0
01010	111.11	133.33	66.67	66.67	33.335	666.7
01011	166.60	133.28	66.64	66.64	32.22	666.4
01100	66.80	66.80	66.80	66.80	33.40	400.8
01101	66.80	66.80	50.10	50.10	25.05	400.8
01110	100.20	133.60	100.20	66.80	33.40	400.8
01111	100.20	133.60	80.16	66.80	33.40	400.8
10000	100.20	167.00	83.50	62.63	31.315	501.0
10001	100.20	167.00	100.20	62.63	31.315	501.0
10010	102.20	136.27	68.13	68.13	34.065	408.8
10011	133.40	200.10	66.70	66.70	33.35	400.2
10100	105.00	140.00	70.00	70.00	35.00	420.0
10101	83.33	138.89	69.44	69.44	34.72	416.6
10110	108.00	144.00	72.00	72.00	36.00	432.0
10111	83.33	104.16	69.44	69.44	34.72	416.6
11000	116.00	145.00	64.44	64.44	32.22	580.0
11001	83.33	166.67	62.50	62.50	31.25	500.0
11010	120.00	150.00	66.67	66.67	33.335	600.0
11011	95.00	142.50	63.33	63.33	31.665	570.0
11100	112.00	140.00	62.22	62.22	31.11	560.0
11101	75.00	125.00	62.50	62.50	31.25	375.0
11110	108.00	180.00	67.50	67.50	33.75	540.0
11111	95.00	158.33	79.17	79.17	39.585	475.0

Pin Description ^[2]

Pin	Name	PWR	I/O	Description
6	XIN		I	Oscillator buffer input. Connect to a crystal or to an external clock.
7	XOUT	VDDR	O	Oscillator buffer output. Connect to a crystal. Do not connect when an external clock is applied at XIN.
39,40,43,44	CPU (0:1)T, CPU (0:1)C	VDDC	O	Differential host output clock pairs. See <i>Table 1</i> for frequencies and functionality.
16,17,20,23	PCI (0:5)	VDDP	O	PCI clock outputs. See <i>Table 1</i> .
14	FS3/PCI_F0	VDDP	I/O PD	Power-on bidirectional Input/Output (I/O). At power-up, FS3 is the input. When VTTTPWRGD transitions to a logic HIGH, FS3 state is latched and this pin becomes PCI_F0 clock output. See <i>Table 1</i> .
15	FS4/PCI_F1	VDDP	I/O PD	Power-on bidirectional I/O. At power-up, FS4 is the input. When VTTTPWRGD transitions to a logic HIGH, FS4 state is latched and this pin becomes PCI_F1 Clock Output. See <i>Table 1</i> .
2	FS0/REF0	VDDR	I/O PD	Power-on bidirectional I/O. At power-up, FS0 is the input. When VTTTPWRGD transitions to a logic HIGH, FS0 state is latched and this pin becomes REF0, buffered Output copy of the device's XIN clock.
3	FS1/REF1	VDDR	I/O PD	Power-on bidirectional I/O. At power-up, FS1 is the input. When VTTTPWRGD is transited to logic LOW, FS1 state is latched and this pin becomes REF1, buffered Output copy of the device's XIN clock.
4	FS2/REF2	VDDR	I/O PD	Power-on bidirectional I/O. At power-up, FS2 is the input. When VTTTPWRGD is transited to logic LOW, FS2 state is latched and this pin becomes REF2, buffered Output copy of the device's XIN clock.
38	IREF		I	Current reference programming input for CPU buffers. A resistor is connected between this pin and V_{SS} . See <i>Figure 8</i> .
33	PD#/VTTTPR GD		I PU	Power-down input/VTT power good input. At power-up, VTTTPWRGD is the input. When this input is transitions initially from LOW to HIGH, the FS (0:4) and MULT0 are latched. After the first LOW-to-HIGH transition, this pin becomes a PD# input with an internal pull-up. When PD# is asserted LOW, the device enters power-down mode. See power management function.
27	48M	VDD48M	O	Fixed 48-MHz USB clock output.
26	24_48M/MUL T0	VDD48M	I/O PU	Power-on bidirectional I/O. At power-up, MULT0 is the input. When VTTTPWRGD is transitions to logic HIGH MULT0 state is latched and this pin becomes 24_48M, SIO programmable clock output.
9,10	ZCLK (0:1)	VDDZ	O	HyperZip Clock Outputs. See <i>Table 1</i> .
34	SDATA		I/O	Serial Data Input. Conforms to the SMBus specification of a Slave Receive/Transmit device. It is an input when receiving data, and an open drain output when acknowledging or transmitting data.
35	SCLK		I	Serial Clock Input. Conforms to the SMBus specification.
12	SRESET#		O	PCI Clock Disable Input. If Byte12 Bit7 = 0, this pin becomes an SRESET# open drain output, and the internal pull-up is not active. See system reset description.
	PCI_STP#		I PU	System Reset Control Output. If Byte12 Bit7 = 1 (Default), this pin becomes PCI Clock Disable Input. When PCI_STP# is asserted LOW, PCI (0:5) clocks are synchronously disabled in a LOW state. This pin does not affect PCI_F (0:1) if they are programmed to be free-running clocks via the device's SMBus interface.
45	CPU_STP#		I PU	CPU Clock Disable Input. When asserted LOW, CPU (0:1)T clocks are synchronously disabled in a HIGH state and CPU (0:1)C clocks are synchronously disabled in a LOW state.

Pin Description (continued)^[2]

Pin	Name	PWR	I/O	Description
47	SDCLK	VDDSD	O	SDRAM Clock Output.
30,31	AGP (0:1)	VDDAGP	O	AGP Clock Outputs. See <i>Table 1</i> for frequencies and functionality.
48	VDDSD		PWR	3.3V power supply for SDRAM clock output.
29	VDDAGP		PWR	3.3V power supply for AGP clock output.
11	VDDZ		PWR	3.3V power supply for HyperZip clock output.
1	VDDR		PWR	3.3V power supply for REF clock output.
13,19	VDDP		PWR	3.3V power supply for PCI clock output.
42	VDDC		PWR	3.3V power supply for CPU clock output.
28	VDD48M		PWR	3.3V power supply for 48-MHz/24-MHz clock output.
36	VDDA		PWR	3.3V analog power supply.
18,24	VSSP		PWR	GND for PCI clocks outputs.
41	VSSC		PWR	GND for CPU clocks outputs.
8	VSSZ		PWR	GND for HyperZip clocks outputs.
25	VSS48M		PWR	GND for 48-MHz/24-MHz clocks outputs.
5	VSSR		PWR	GND for REF clocks outputs.
46	VSSSD		PWR	GND for SDRAM clocks outputs.
32	VSSAGP		PWR	GND for AGP clocks outputs.
37	VSSA		PWR	GND for analog.

Serial Data Interface

To enhance the flexibility and function of the clock synthesizer, a two-signal serial interface is provided. Through the Serial Data Interface (SDI), various device functions such as individual clock output buffers, etc., can be individually enabled or disabled.

The registers associated with the SDI initialize to their default setting upon power-up, and therefore the use of this interface is optional. Clock device register changes are normally made upon system initialization, if any are required. The interface can also be used during system operation for power management functions.

Note:

2. PU = Internal pull-up. PD = internal pull-down. T = Tri-level logic input with valid logic voltages of LOW = < 0.8V, T = 1.0 – 1.8V, and HIGH = > 2.0V.

Data Protocol

The clock driver serial protocol accepts byte Write, byte Read, block Write, and block Read operations from the controller. For a block Write/Read operation, the bytes must be accessed in sequential order from lowest to highest byte (most significant bit first) with the ability to stop after any complete byte has been transferred. For byte Write and byte Read operations, the system controller can access individual indexed bytes. The offset of the indexed byte is encoded in the command code, as described in *Table 2*.

The block Write and block Read protocol is outlined in *Table 3* while *Table 4* outlines the corresponding byte Write and byte Read protocol.

The slave receiver address is 11010010 (D2h).

Table 2. Command Code Definition

Bit	Description
7	0 = Block Read or block Write operation 1 = Byte Read or byte Write operation
(6:0)	Byte offset for byte Read or byte Write operations. For block Read or block Write operations, these bits should be "0000000"

Table 3. Block Read and Block Write Protocol

Block Write Protocol		Block Read Protocol	
Bit	Description	Bit	Description
1	Start	1	Start
2:8	Slave address – 7 bits	2:8	Slave address – 7 bits
9	Write	9	Write
10	Acknowledge from slave	10	Acknowledge from slave
11:18	Command code – 8-bit "00000000" stands for block operation	11:18	Command code – 8-bit "00000000" stands for block operation
19	Acknowledge from slave	19	Acknowledge from slave
20:27	Byte count – 8 bits	20	Repeat start
28	Acknowledge from slave	21:27	Slave address – 7 bits
29:36	Data byte 0 – 8 bits	28	Read
37	Acknowledge from slave	29	Acknowledge from slave
38:45	Data byte 1 – 8 bits	30:37	Byte count from slave – 8 bits
46	Acknowledge from slave	38	Acknowledge
....	Data byte N/slave acknowledge...	39:46	Data byte from slave – 8 bits
....	Data byte N – 8 bits	47	Acknowledge
....	Acknowledge from slave	48:55	Data byte from slave – 8 bits
....	Stop	56	Acknowledge
		Data bytes from slave/acknowledge
		Data byte N from slave – 8 bits
		Not acknowledge
		Stop

Table 4. Byte Read and Byte Write Protocol

Byte Write Protocol		Byte Read Protocol	
Bit	Description	Bit	Description
1	Start	1	Start
2:8	Slave address – 7 bits	2:8	Slave address – 7 bits
9	Write	9	Write
10	Acknowledge from slave	10	Acknowledge from slave
11:18	Command Code – 8 bit "1xxxxxx" stands for byte operation bit[6:0] of the command code represents the offset of the byte to be accessed	11:18	Command Code – 8-bit "1xxxxxx" stands for byte operation bit[6:0] of the command code represents the offset of the byte to be accessed
19	Acknowledge from slave	19	Acknowledge from slave
20:27	Byte count – 8 bits	20	Repeat start
28	Acknowledge from slave	21:27	Slave address – 7 bits
29	Stop	28	Read
		29	Acknowledge from slave

Table 4. Byte Read and Byte Write Protocol (continued)

Byte Write Protocol		Byte Read Protocol	
Bit	Description	Bit	Description
		30:37	Data byte from slave – 8 bits
		38	Not acknowledge
		39	Stop

Since SDR and DDR Zero Delay Buffers will share this same address, the device starts from Byte 4.

Byte 4: CPU Clock Register (All bits are Read and Write functional)

Bit	@Pup	Pin#	Name	Description
7	H/W Setting	14	FS3	For selecting frequencies in <i>Table 1</i> .
6	H/W Setting	4	FS2	For selecting frequencies in <i>Table 1</i> .
5	H/W Setting	3	FS1	For selecting frequencies in <i>Table 1</i> .
4	H/W Setting	2	FS0	For selecting frequencies in <i>Table 1</i> .
3	0			0 = HW, 1 = SW frequency selection.
2	H/W Setting	15	FS4	For selecting frequencies in <i>Table 1</i> .
1	1		SSCG	Spread Spectrum Enable. 0 = spread off, 1 = spread on. This is a Read and Write control bit.
0	0			Master output control 0 = running, 1 = three-state all outputs.

Byte 5: CPU Clock Register (all bits are Read-only)

Bit	@Pup	Pin#	Name	Description
7	0			Reserved.
6	0			Reserved.
5	X	26	MULT0	MULT0 (pin 26) value. This bit is Read-only.
4	X	15	FS4	FS4 Read-back. This bit is Read-only.
3	X	14	FS3	FS3 Read-back. This bit is Read-only.
2	X	4	FS2	FS2 Read-back. This bit is Read-only.
1	X	3	FS1	FS1 Read-back. This bit is Read-only.
0	X	2	FS0	FS0 Read-back. This bit is Read-only.

Byte 6: CPU Clock Register (All bits are Read and Write functional)

Bit	@Pup	Pin#	Name	Description
7	0			Function Test Bit. Always program to 0.
6	0			Reserved.
5	0	14	PCI_F0	PCI_STP# control of PCI_F0. 0 = free running, 1 = stopped when PCI_STP# is LOW.
4	0	15	PCI_F1	PCI_STP# control of PCI_F1. 0 = free running, 1 = stopped when PCI_STP# is LOW.
3	1	40,39	CPU0T/C	Controls CPU0T and CPU0C functionality when CPU_STP# is asserted LOW. 0 = free running, 1 = stopped with CPU_STP# asserted LOW. This is a Read and Write control bit.
2	0	44,43	CPU1T/C	Controls CPU1T and CPU1C functionality when CPU_STP# is asserted LOW. 0 = Free Running, 1 Stopped with CPU_STP# asserted to LOW. This and Read and Write control bit.
1	1	40,39	CPU0T/C	CPU0T, CPU0C output control, 1= enabled, 0 = disabled. This is a Read and Write control bit.
0	1	44,43	CPU1T/C	CPU1T, CPU1C output control, 1= enabled, 0 = disabled. This is a Read and Write control bit.

Byte 7: PCI Clock Register (All bits are Read and Write functional)

Bit	@Pup	Pin#	Name	Description
7	1	15	PCI_F0	PCI_F0 output control 1 = enabled, 0 = forced LOW.
6	1	14	PCI_F1	PCI_F1 output control 1 = enabled, 0 = forced LOW.
5	1	23	PCI5	PCI5 output control 1 = enabled, 0 = forced LOW.
4	1	22	PCI4	PCI4 output control 1 = enabled, 0 = forced LOW.
3	1	21	PCI3	PCI3 output control 1 = enabled, 0 = forced LOW.
2	1	20	PCI2	PCI2 output control 1 = enabled, 0 = forced LOW.
1	1	17	PCI1	PCI1 output control 1 = enabled, 0 = forced LOW.
0	1	16	PCI0	PCI0 output control 1 = enabled, 0 = forced LOW.

Byte 8: Silicon Signature Register (all bits are Read-only)

Bit	@Pup	Description
7	1	Vendor ID 1000 = Cypress
6	0	
5	0	
4	0	
3	0	Revision ID
2	0	
1	0	
0	0	

Byte 9: Peripheral Control Register (All bits are Read and Write)

Bit	@Pup	Pin#	Name	Description
7	1	33	PD#	PD# Enable. 0 = enable, 1 = disable.
6	0			0 = when PD# asserted LOW, CPU(0:1)T stop in a high state, CPU(0:1)C stop in a LOW state. 1 = when PD# asserted LOW, CPU(0:1)T and CPU(0:1)C stop in H-Z.
5	1	27	48M	48M output control 1 = enabled, 0 = forced LOW.
4	1	26	48M_24M	48M_24M output control 1 = enabled, 0 = forced LOW.
3	0	26	48M_24M	48M_24M, 0 = pin 26 output is 24MHz, 1= pin 28 output is 48 MHz.
2	0			SS2 Spread Spectrum control bit (0= down spread, 1= center spread).
1	0			SS1 Spread Spectrum control bit. See <i>Table 9</i> .
0	0			SS0 Spread Spectrum control bit. See <i>Table 9</i> .

Byte 10: Peripheral Control Register (All bits are Read and Write functional)

Bit	@Pup	Pin#	Name	Description
7	1	47	SDCLK	SDCLK output enable 1 = enabled, 0 = disabled.
6	1	4	REF2	REF2 output control 1 = enabled, 0 = forced LOW.
5	1	3	REF1	REF1 output control 1 = enabled, 0 = forced LOW.
4	1	2	REF0	REF0 output control 1 = enabled, 0 = forced LOW.
3	1	10	ZCLK1	ZCLK1 output enable 1 = enabled, 0 = disabled.
2	1	9	ZCLK0	ZCLK0 output enabled 1 = enabled, 0 = disabled.
1	1	30	AGP1	AGP1 output enabled 1 = enabled, 0 = disabled.
0	1	31	AGP0	AGP0 output enabled 1 = enabled, 0 = disabled.

Byte 11: Dial-a-Skew™ and Dial-a-Ratio™ Control Register (All bits are Read and Write functional)

Bit	@Pup	Name	Description
7	0	DARSD2	Programming these bits allows modifying the frequency ratio of the SDCLK clock relative to the VCO. See <i>Table 5</i> .
6	0	DARSD1	
5	0	DARSD0	
4	0	DARAG2	Programming these bits allows modifying the frequency ratio of the AGP(1:0), PCI(5:0) and PCIF(0:1) clocks relative to the VCO. See <i>Table 6</i> .
3	0	DARAG1	
2	0	DARAG0	
1	0	DASSD1	Programming these bits allows shifting skew between CPU and SDCLK signals. See <i>Table 7</i> .
0	0	DASSD0	

Table 5. Dial-a-Ratio SDCLK

DARSD (2:0)	VC0/SDCLK ratio
000	Frequency selection default
001	2
010	3
011	4
100	5
101	6
110	8
111	9

Table 6. Dial-a-Ratio AGP(0:1)^[3]

DARAG (2:0)	VC0/AGP Ratio
000	Frequency selection default
001	6
010	7
011	8
100	9
101	10
110	10
111	10

Table 7. Dial-a-Skew SDCLK CPU

DASSD (1:0)	SDCLK-CPU Skew
00	0 ps (default) ^[4]
01	+150 ps (CPU lag)*
10	+300 ps (CPU lag)*
11	+450 ps (CPU lag)*

Notes:

3. The ratio of AGP to PCI is retained at 2:1.
4. See *Figure 8* for CPU measurement point. See *Figure 9* for SDCLK measurement point.

Byte 12: Watchdog Time Stamp Register (All bits are Read and Write functional)

Bit	@Pup	Name	Description
7	1		SRESET#/PCI_STP#. 1 = pin 12 is the input pin as PCI_STP# signal. 0 = pin 12 is the output pin as SRESET# signal.
6	0		Frequency Revert. This bit allows setting the Revert Frequency once the system is rebooted due to Watchdog time-out only. 0 = selects frequency of existing H/W setting. 1 = selects frequency of the second to last S/W setting (the software setting prior to the one that caused a system reboot).
5	0		WDTEST. For WD-Test, ALWAYS program to "0."
4	0		WD Alarm. This bit is set to "1" when the Watchdog times out. It is reset to "0" when the system clears the WD time stamps (WD3:0).
3	0	WD3	These bits select the Watchdog Time Stamp Value. See <i>Table 8</i> .
2	0	WD2	
1	0	WD1	
0	0	WD0	

Table 8. Watchdog Time Stamp Table

WD(3:0)	FUNCTION
0000	Off
0001	1 second
0010	2 seconds
0011	3 seconds
0100	4 seconds
0101	5 seconds
0110	6 seconds
0111	7 seconds
1000	8 seconds
1001	9 seconds
1010	10 seconds
1011	11 seconds
1100	12 seconds
1101	13 seconds
1110	14 seconds
1111	15 seconds

Byte 13: Dial-a-Frequency Control Register N (All bits are Read and Write functional)^[5]

Bit	@Pup	Description
7	0	Reserved.
6	0	N6, MSB
5	0	N5
4	0	N4
3	0	N3
2	0	N2
1	0	N3
0	0	N0, LSB

Note:

5. Byte 13 and Byte 14 should be Write together in every case.

Byte 14: Dial-a-Frequency Control Register (All bits are Read and Write functional)^[5]

Bit	@Pup	Description
7	0	Reserved.
6	0	R5 MSB
5	0	R4
4	0	R3
3	0	R2
2	0	R1
1	0	R0, LSB
0	0	R and N Register Load Gate. 0 = gate closed (data is latched), 1 = gate open (data is loading from SMBus registers into R and N)#.

Dial-a-Frequency Feature

SMBus Dial-a-Frequency feature is available in this device via byte 13 and byte 14. P is a large-value, phase-locked loop (PLL) constant that depends on the frequency selection achieved through the hardware selectors FS(4:0). P value may be determined from the following table.

FS(4:0)	P
00000, 00001, 00010, 00111, 01001, 01011, 01110, 01111, 10010, 10100, 10110	95996900
00100, 00101, 10000, 10001, 10101, 10111, 11000, 11010, 11100, 11101, 11110, 11111	76797520
00110, 01000, 01010, 01100, 01101, 11001, 11011	63997933
00011, 10011	127995867

Spread Spectrum Clock Generation (SSCG)

Spread Spectrum is a modulation technique used to minimize electromagnetic interference (EMI) radiation generated by repetitive digital signals. A clock presents the greatest EMI energy at the center of the frequency it is generating. Spread Spectrum distributes this energy over a specific and controlled frequency bandwidth, thereby causing the average energy at any one point in this band to decrease in value. This technique is achieved by modulating the clock away from its resting frequency by a certain percentage (which also determines the amount of EMI reduction). In this device, Spread Spectrum is enabled by setting specific register bits in the SMBus control bytes. See the SMBus register section of this data sheet for the exact bit and byte functionally. The following table is a listing of the modes and percentages of Spread Spectrum modulation that this device incorporates.

Table 9. Spread Spectrum

SS2	SS1	SS0	Spread Mode	Spread%
0	0	0	Down	0, -0.50
0	0	1	Down	+0.12, -0.62
0	1	0	Down	+0.25, -0.75
0	1	1	Down	+0.50, -1.00
1	0	0	Center	+0.25, -0.25
1	0	1	Center	+0.37, -0.37
1	1	0	Center	+0.50, -0.50
1	1	1	Center	+0.75, -0.75

System Self-recovery Clock Management

This feature is designed to allow the system designer to change frequency while the system is running and reboot the operation of the system in case of a hang up due to the frequency change.

When the system sends an SMBus command requesting a frequency change through byte 4 or through bytes 13 and 14, it must have previously sent a command selecting which time-out stamp the Watchdog must perform to byte 12, or the system self-recovery feature will not be applicable. Consequently this device will change frequency, and then the Watchdog timer starts timing. Meanwhile, the system BIOS is running its operation with the new frequency. If this device receives a new SMBus command to clear the bits originally programmed in byte 12, bits(3:0) (reprogram to 0000) before

Watchdog times out, this device will keep operating in its normal condition with the new selected frequency. If the Watchdog times out the first time before the new SMBus reprograms byte 12, bits(3:0) to (0000), then this device will send a low system reset pulse, on SRESET# (see byte 12, bit 7), and changes the Watchdog alarm (byte 12, bit 4) status to "1" then restarts the Watchdog timer. If the Watchdog times out a second time, this device will send another low pulse on SRESET#, will relatch original hardware strapping frequency (or second-to-last software-selected frequency, see byte 12, bit6) selection, set Watchdog alarm bit (byte 12, bit4) to "1," then start the Watchdog timer again. The above-described sequence will keep repeating until the BIOS clears the SMBus byte 12 bits(3:0). Once the BIOS sets byte 12 bits(3:0) = 0000, the Watchdog timer is turned off and the Watchdog alarm bit (byte 12, bit 4) is reset to "0."

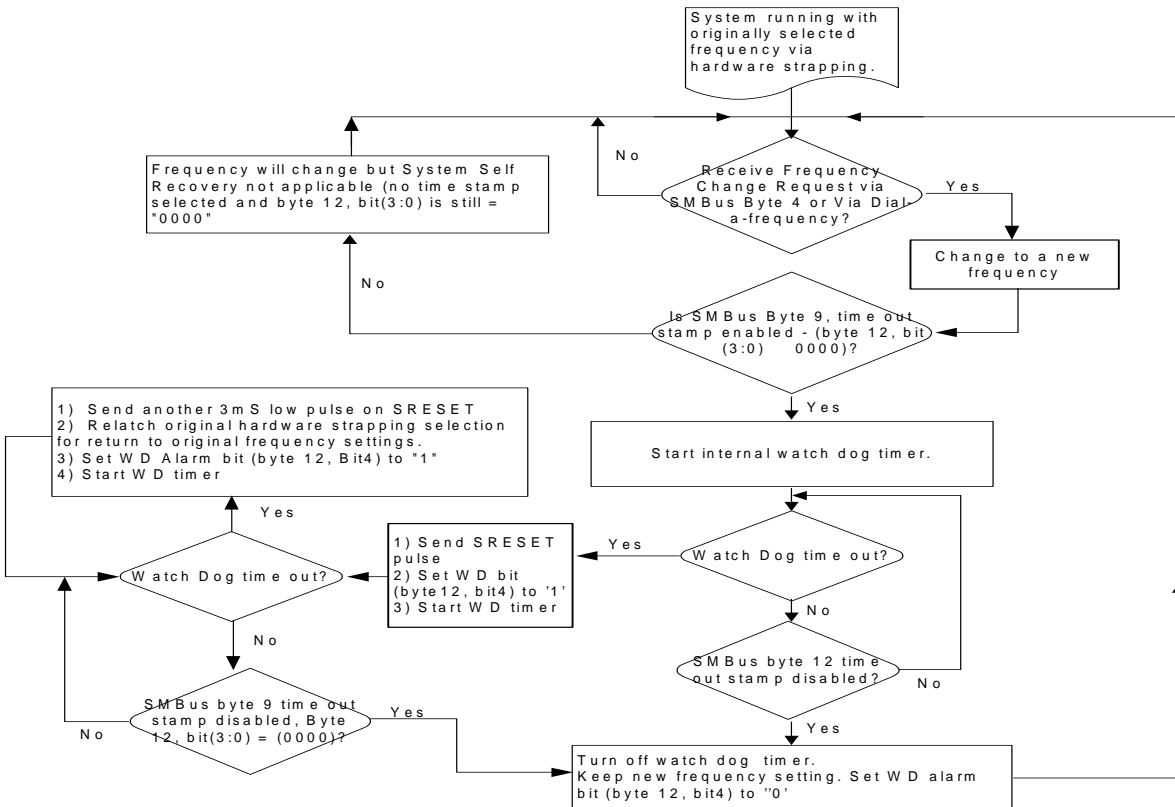

Table 10. CPU Clock Current Select Function

Mult0	Board Target Trace/Term Z	Reference R, Iref – V _{DD} (3*Rr)	Output Current	Voh @ Z
0	50 Ohms (not used)	Rr = 221 1%, Iref = 5.00mA	I _{OH} = 4*Iref	1.0V @ 50
1	50 Ohms	Rr = 475 1%, Iref = 2.32mA	I _{OH} = 6*Iref	0.7V @ 50

Table 11. Group Timing Relationship and Tolerances

	Offset	Tolerance (or Range)	Conditions	Notes
CPU to SDCLK	Typical 0 ns	±2 ns	CPU leads	Note 6
CPU to AGP	Typical 2 ns	1-4ns	CPU leads	Note 6
CPU to ZCLK	Typical 2 ns	1-4ns	CPU leads	Note 6
CPU to PCI	Typical 2 ns	1-4ns	CPU leads	Note 6

Note:

6. See *Figure 8* for CPU clock-measurement point. See *Figure 9* for SDCLK, AGP, ZCLK and PCI output-measurement points.

CPU_STP# Clarification

The CPU_STP# signal is an active LOW input used for synchronous stopping and starting of the CPU output clocks while the rest of the clock generator continues to function.

CPU_STP# Assertion

When CPU_STP# pin is asserted, all CPU outputs that are set with the SMBus configuration to be stoppable via assertion of CPU_STP# will be stopped after being sampled by two falling CPU clock edges. The final state of the stopped CPU signals is CPU = HIGH and CPU0# = LOW. There is no change to the output drive current values during the stopped state. The CPU

is driven HIGH with a current value equal to (Mult0 "select") × (Iref), and the CPU# signal will not be driven. Due to external pull-down circuitry, CPU# will be LOW during this stopped state.

CPU_STP# Deassertion

The deassertion of the CPU_STP# signal will cause all CPU outputs that were stopped to resume normal operation in a synchronous manner. Synchronous manner meaning that no short or stretched clock pulses will be produced when the clock resumes. The maximum latency from the deassertion to active outputs is no more than two CPU clock cycles.

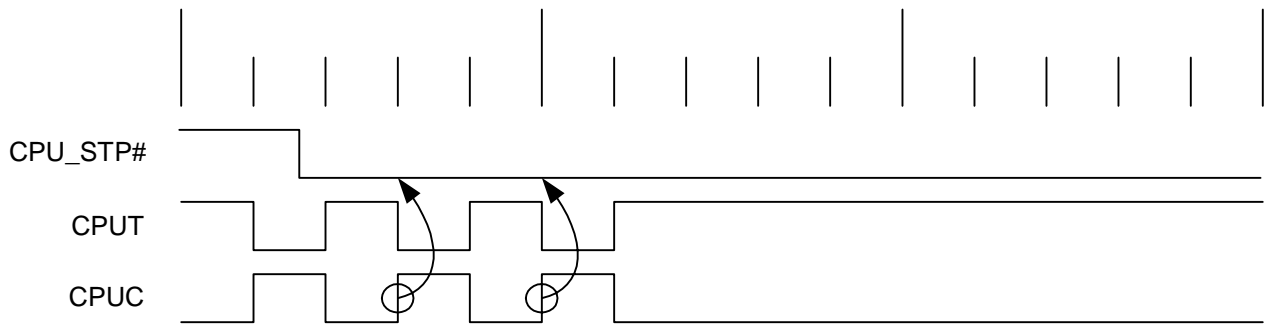

Figure 1. Assertion CPU_STP# Waveform

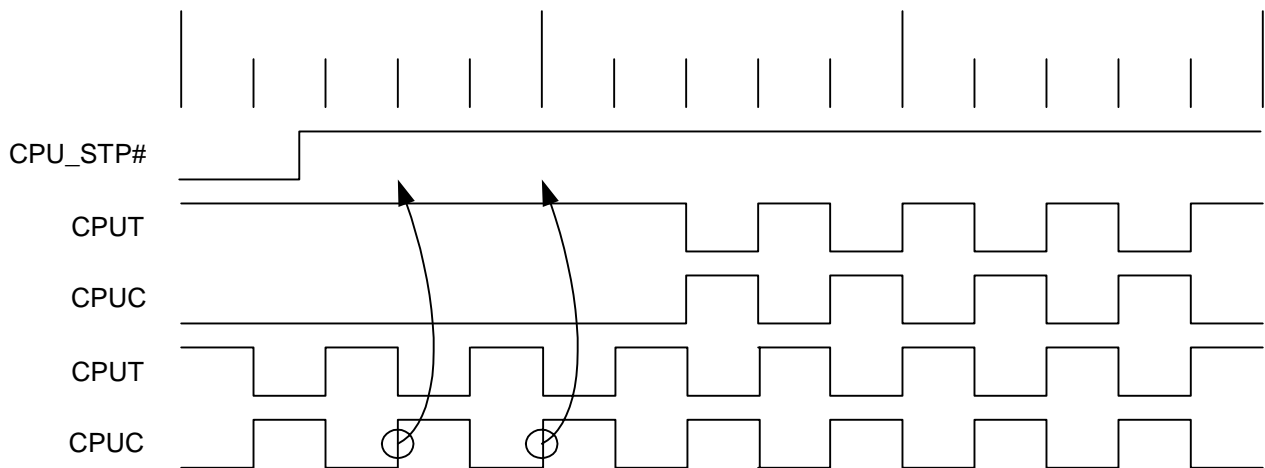

Figure 2. Deassertion CPU_STP# Waveform

PCI_STP# Assertion

The PCI_STP# signal is an active LOW input used for synchronous stopping and starting the PCI outputs while the rest of the clock generator continues to function. The set-up time for capturing PCI_STP# going LOW is 10 ns (t_{setup}). (See Figure 3.) The PCI_F (0:2) clocks will not be affected by this

pin if their control bits in the SMBus register are set to allow them to be free running.

PCI_STP# Deassertion

The deassertion of the PCI_STP# signal will cause all PCI(0:6) and stoppable PCI_F(0:2) clocks to resume running in a synchronous manner within two PCI clock periods after PCI_STP# transitions to a high level.

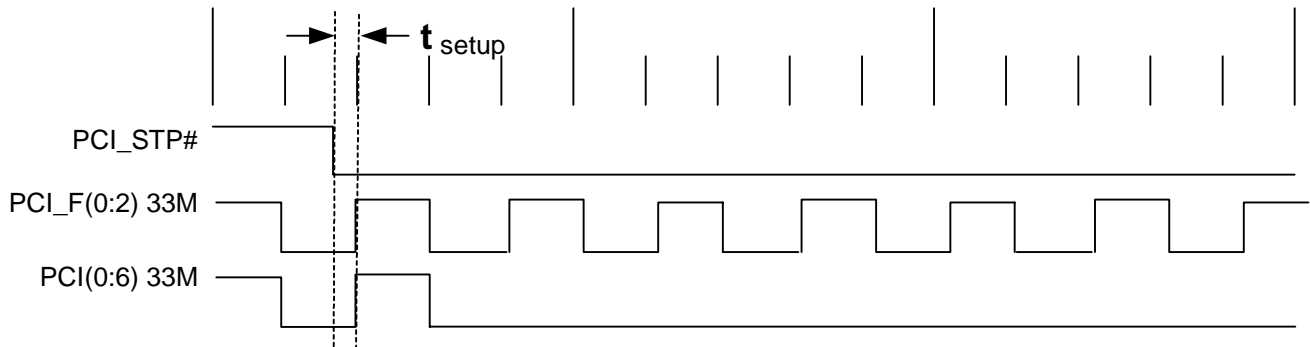

Figure 3. Assertion PCI_STP# Waveform

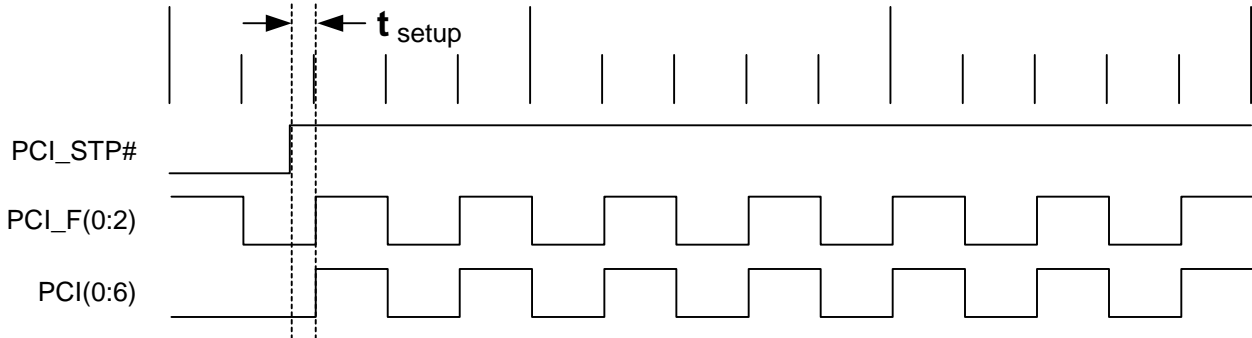

Figure 4. Deassertion PCI_STP# Waveform^[7]

Note:

- The PCI STOP function is controlled by 2 inputs. One is the device PCI_STP# pin number 34 and the other is SMBus byte 0 bit 3. These 2 inputs are logically ANDed. If either the external pin or the internal SMBus register bit is set low then the stoppable PCI clocks will be stopped in a logic low state. Reading SMBus Byte 0 Bit 3 will return a 0 value if either of these control bits are set LOW thereby indicating the device's stoppable PCI clocks are not running.

PD# (Power-Down) Clarification

The PD# (power-down) pin is used to shut off ALL clocks prior to shutting off power to the device. PD# is an asynchronous active LOW input. This signal is synchronized internally to the device powering down the clock synthesizer. PD# is an asynchronous function for powering up the system. When PD# is low, all clocks are driven to a LOW value and held there and the VCO and PLLs are also powered down. All clocks are shut down in a synchronous manner so has not to cause glitches while transitioning to the low "stopped" state.

PD# - Assertion (transition from logic "1" to logic "0")

When PD# is sampled LOW by two consecutive rising edges of CPUC clock then all clock outputs (except CPUC) clocks must be held LOW on their next HIGH-to-LOW transition. CPUC clocks must be hold with CPUC clock pin driven HIGH with a value of 2x Iref and CPUC undriven.

Due to the state of the internal logic, stopping and holding the REF clock outputs in the LOW state may require more than one clock cycle to complete.

PD# Deassertion (transition from logic "0" to logic "1")

The power-up latency between PD# rising to a valid logic "1" level and the starting of all clocks is less than 3.0 ms.

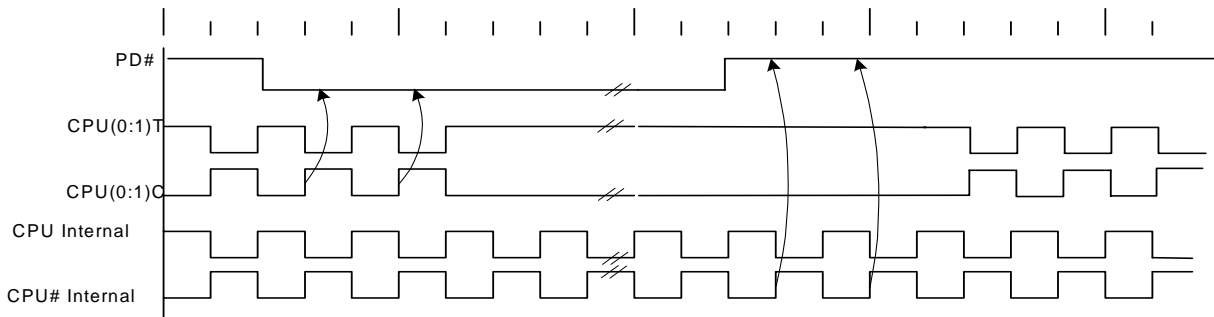

Figure 5. Power-down Assertion/Deassertion Timing Waveforms – Nonbuffered Mode

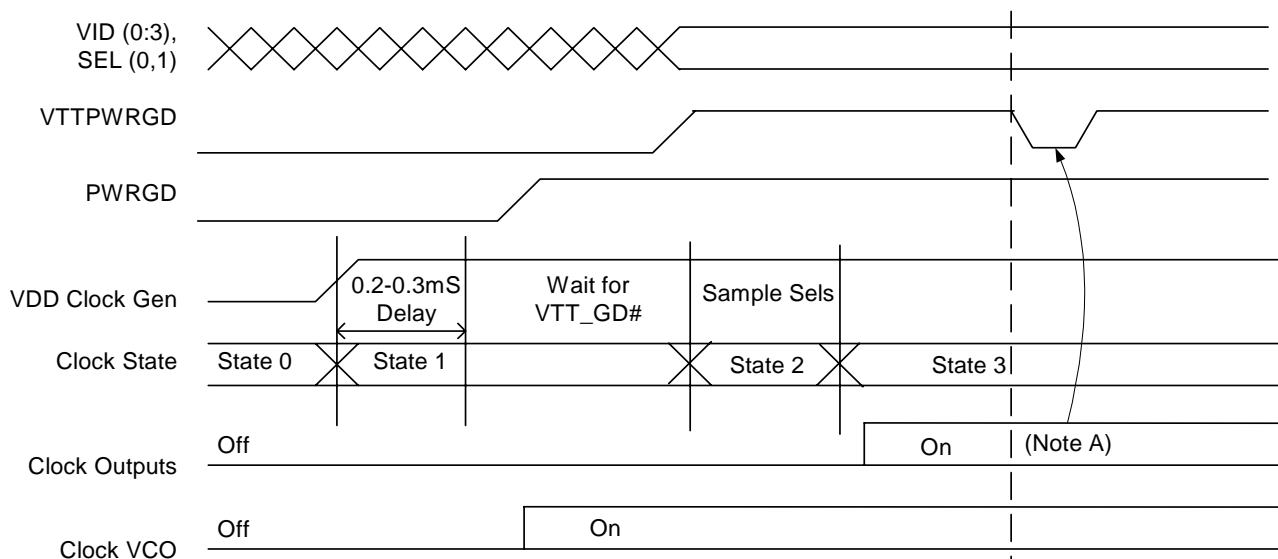

Figure 6. VTPWRGD Timing Diagram^[8]

Note:

8. Device is not affected; VTPWRGD is ignored.

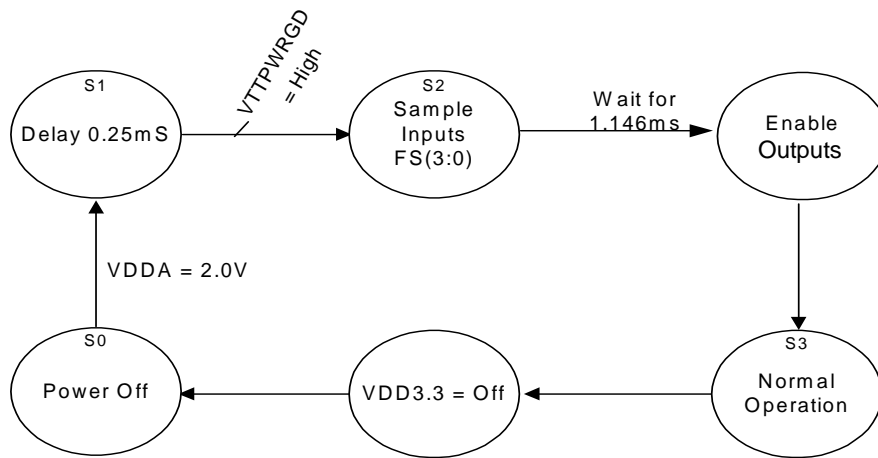

Figure 7. Clock Generator Power-up/Run State Diagram

Maximum Ratings

Input Voltage Relative to V_{SS} $V_{SS} - 0.3V$
 Input Voltage Relative to V_{DDQ} or AV_{DD} : $V_{DD} + 0.3V$

Storage Temperature:..... $-65^{\circ}C$ to $+150^{\circ}C$
 Operating Temperature: $0^{\circ}C$ to $+70^{\circ}C$
 Maximum Power Supply:..... $3.5V$

DC Characteristics
Current Accuracy^[9]

	Conditions	Configuration	Load	Min.	Max.
I _{out}	$V_{DD} = \text{nominal (3.30V)}$	M0= 0 or 1 and R _r shown in table	Nominal test load for given configuration	-7% I _{nom}	+7% I _{nom}
I _{out}	$V_{DD} = 3.30 \pm 5\%$	All combinations of M0 or 1 and R _r shown in table	Nominal test load for given configuration	-12% I _{nom}	+12% I _{nom}

DC Component Parameters ($V_{DD} = 3.3V \pm 5\%$, $T_A = 0^{\circ}C$ to $70^{\circ}C$)

Parameter	Description	Min.	Typ.	Max.	Units	Conditions
I _{dd3.3V}	Dynamic Supply Current			280	mA	All frequencies at maximum values ^[10]
I _{pd3.3V}	Power-down Supply Current			Note 11	mA	PD# Asserted
C _{in}	Input Pin Capacitance			5	pF	
C _{out}	Output Pin Capacitance			6	pF	
L _{pin}	Pin Inductance			7	nH	
C _{x_{tal}}	Crystal Pin Capacitance	30	36	42	pF	Measured from the X _{IN} or X _{OUT} Pin to Ground

AC Parameters

Parameter	Description	100 MHz		133 MHz		Unit	Notes
		Min.	Max.	Min.	Max.		
Crystal							
TDC	X _{IN} Duty Cycle	47.5	52.5	47.5	52.5	%	12,13
TPeriod	X _{IN} period	69.841	71.0	69.841	71.0	ns	12,13,14,15
VHIGH	X _{IN} HIGH Voltage	0.7V _{DD}	V _{DD}	0.7V _{DD}	V _{DD}	V	
VLOW	X _{IN} LOW Voltage	0	0.3V _{DD}	0	0.3V _{DD}	V	
Tr/Tf	X _{IN} Rise and Fall Times		10.0		10.0	ns	
TCCJ	X _{IN} Cycle to Cycle Jitter		500		500	ps	13,14,16
CPU at 0.7V Timing							
TSKEW	Any CPU to CPU Clock Skew		150		150	ps	16, 17, 18
TCCJ	CPU Cycle to Cycle Jitter		150		150	ps	16, 17, 18
TDC	CPU and CPUC Duty Cycle	45	55	45	55	%	16, 17, 18
TPeriod	CPU and CPUC Period	9.8	10.2	7.35	7.65	ns	16, 17, 18

Notes:

9. I_{nom} refers to the expected current based on the configuration of the device.
10. All outputs loaded as per maximum capacitive load table.
11. Absolute value = (programmed CPU I_{ref} 97) +10 mA.
12. This parameter is measured as an average over 1- μ s duration with a crystal center frequency of 14.318 MHz.
13. When X_{IN} is driven from an external clock source.
14. All outputs loaded per Table 12 below.
15. Probes are placed on pins and measurements are acquired at 1.5V for 3.3V signals (see test and measurement set-up section).
16. This measurement is applicable with Spread ON or Spread OFF.
17. Measured at crossing point (V_x), or where subtraction of CLK-CLK# crosses 0V.
18. For CPU load. See Figure 8.

AC Parameters (continued)

Parameter	Description	100 MHz		133 MHz		Unit	Notes
		Min.	Max.	Min.	Max.		
Tr/Tf	CPU and CPUC Rise and Fall Times	175	700	175	700	ps	16,19
	Rise/Fall Matching		20%		20%		18,19,20
DeltaTr	Rise Time Variation		125		125	ps	18,19
DeltaTf	Fall Time Variation		125		125	ps	18,19
Vcross	Crossing Point Voltage at 0.7V Swing	280	430	280	430	mV	17,18,19
AGP							
TDC	AGP Duty Cycle	45	55	45	55	%	14, 15
TPeriod	AGP Period	15.0	15.3	15.0	15.3	ns	14, 15
THIGH	AGP HIGH Time	5.25		5.25		ns	21
TLOW	AGP LOW Time	5.05		5.05		ns	22
Tr/Tf	AGP Rise and Fall Times	0.5	1.6	0.5	1.6	ns	14, 23
Tskew Unbuffered	Any AGP to Any AGP Clock Skew		175		175	ps	14, 15
TCCJ	AGP Cycle-to-Cycle Jitter		250		250	ps	14, 15
ZCLK							
TDC	ZCLK(0:1) Duty Cycle	45	55	45	55	%	14, 15
Tr/Tf	ZCLK(0:1) Rise and Fall Times	0.5	1.6	0.5	1.6	ns	14, 23
TSKEW	Any ZCLK(0:1) to Any ZCLK(0:1) Skew		175		175	ps	14, 15
TCCJ	ZCLK(0:1) Cycle-to-Cycle Jitter		250		250	ps	14,15
PCI							
TDC	PCI_F(0:1) PCI (0:5) Duty Cycle	45	55	45	55	%	14, 15
TPeriod	PCI_F(0:1) PCI (0:5) Period	30.0		30.0		nS	12,14,15
THIGH	PCI_F(0:1) PCI (0:5) HIGH Time	12.0		12.0		nS	21
TLOW	PCI_F(0:1) PCI (0:5) LOW Time	12.0		12.0		nS	22
Tr/Tf	PCI_F(0:1) PCI (0:5) Rise and Fall times	0.5	2.0	0.5	2.0	nS	14, 23
TSKEW	Any PCI Clock to Any PCI Clock Skew		500		500	ps	14, 15
TCCJ	PCI_F(0:1) PCI (0:5) Cycle-to-Cycle Jitter		250		250	ps	14, 15
SDCLK							
TDC	SDCLK Duty Cycle	45	55	45	55	%	14, 15
TPeriod	SDCLK Period	9.8	10.2	7.35	7.65	ns	14, 15
THIGH	SDCLK HIGH Time	3.0		1.87		ns	21
TLOW	SDCLK LOW Time	2.8		1.67		ns	22
Tr/Tf	SDCLK Rise and Fall Times	0.4	1.6	0.4	1.6	ns	14, 23
TCCJ	SDCLK Cycle-to-Cycle Jitter	-	250	-	250	ps	14, 23
48M							
TDC	48M Duty Cycle	45	55	45	55	%	14, 15
TPeriod	48M Period	20.829	20.834	20.829	20.834	ns	14, 15
Tr/Tf	48M Rise and Fall Times	1.0	2.0	1.0	2.0	ns	14, 23
TCCJ	48M Cycle-to-Cycle Jitter		350		350	ps	14, 15

Notes:

19. Measured from $V_{OL} = 0.175$ to $V_{OH} = 0.525V$.
20. Determined as a fraction of $2 \cdot (Trise - Tfall) / (Trise + Tfall)$.
21. THIGH is measured at 2.4V for all non-host outputs.
22. TLOW is measured at 0.4V for all non-host outputs.
23. Probes are placed on pins and measurements are acquired between 0.4V and 2.4V for 3.3V signals (see test and measurement set-up section).

AC Parameters (continued)

Parameter	Description	100 MHz		133 MHz		Unit	Notes
		Min.	Max.	Min.	Max.		
24M							
TDC	24-MHz Duty Cycle	45	55	45	55	%	14, 15
TPeriod	24-MHz Period	41.66	41.67	41.66	41.67	ns	14, 15
Tr/Tf	24-MHz Rise and Fall Times	1.0	4.0	1.0	4.0	ns	14, 23
TCCJ	24-MHz Cycle-to-Cycle Jitter		500		500	ps	14, 15
REF							
TDC	REF Duty Cycle	45	55	45	55	%	14, 15
TPeriod	REF Period	69.8413	71.0	69.8413	71.0	ns	14, 15
Tr/Tf	REF Rise and Fall Times	1.0	4.0	1.0	4.0	ns	14, 23
TCCJ	REF Cycle-to-Cycle Jitter		1000		1000	ps	14, 15
ENABLE/DISABLE and SET UP							
tpZL, tpZH	Output Enable Delay (All Outputs)	1.0	10.0	1.0	10.0	ns	
tpLZ, tpZH	Output Disable Delay (All Outputs)	1.0	10.0	1.0	10.0	ns	
tstable	All Clock Stabilization from Power-up		1.5		1.5	ms	
tss	Stopclock Set-up Time	10.0		10.0		ns	
tsh	Stopclock Hold Time	0		0		ns	24

Table 12. Maximum Lumped Capacitive Output Loads

Clock	Max. Load	Units
PCI(0:5), PCI_F(0:1)	30	pF
AGP (0:1), SDCLK	30	pF
ZCLK (0:1)	30	pF
48M_24, 48M Clock	20	pF
REF (0:2)	30	pF
CPU(0:1)T CPU(0:1) C	2	pF

Notes:

24. CPU_STP# and PCI_STP# set-up time with respect to any PCI_F clock to guarantee that the affected clock will stop or start at the next PCI_F clock's rising edge.
25. When crystal meets minimum 40 ohm device series resistance specification.
26. This is required for the duty cycle on the REF clock out to be as specified. The device will operate reliably with input duty cycles up to 30/70, but the REF clock duty cycle will not be within data sheet specifications.

Test and Measurement Set-up

For Differential CPU Output Signals

The following diagram shows lumped test load configurations for the differential Host Clock Outputs.

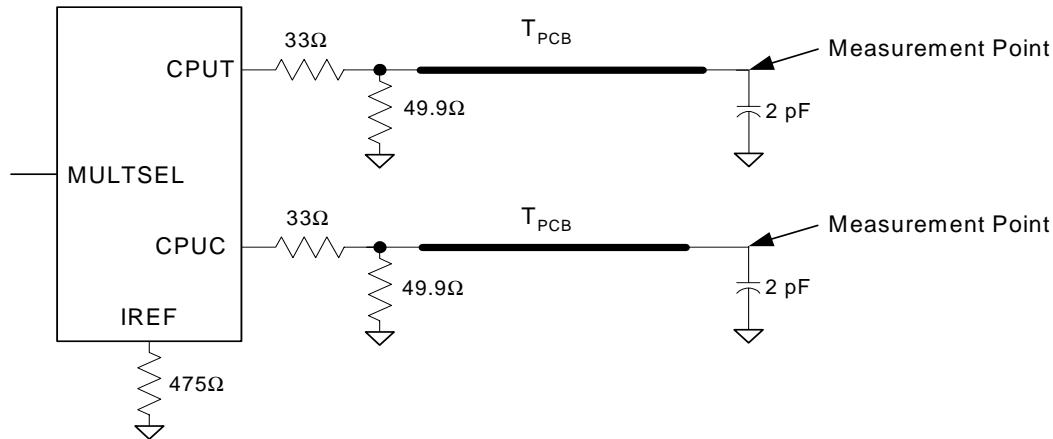

Figure 8. 0.7V Configuration

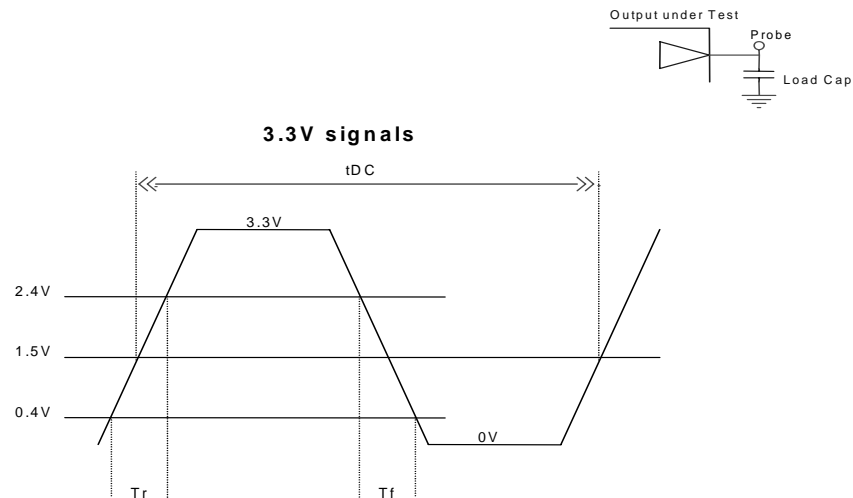
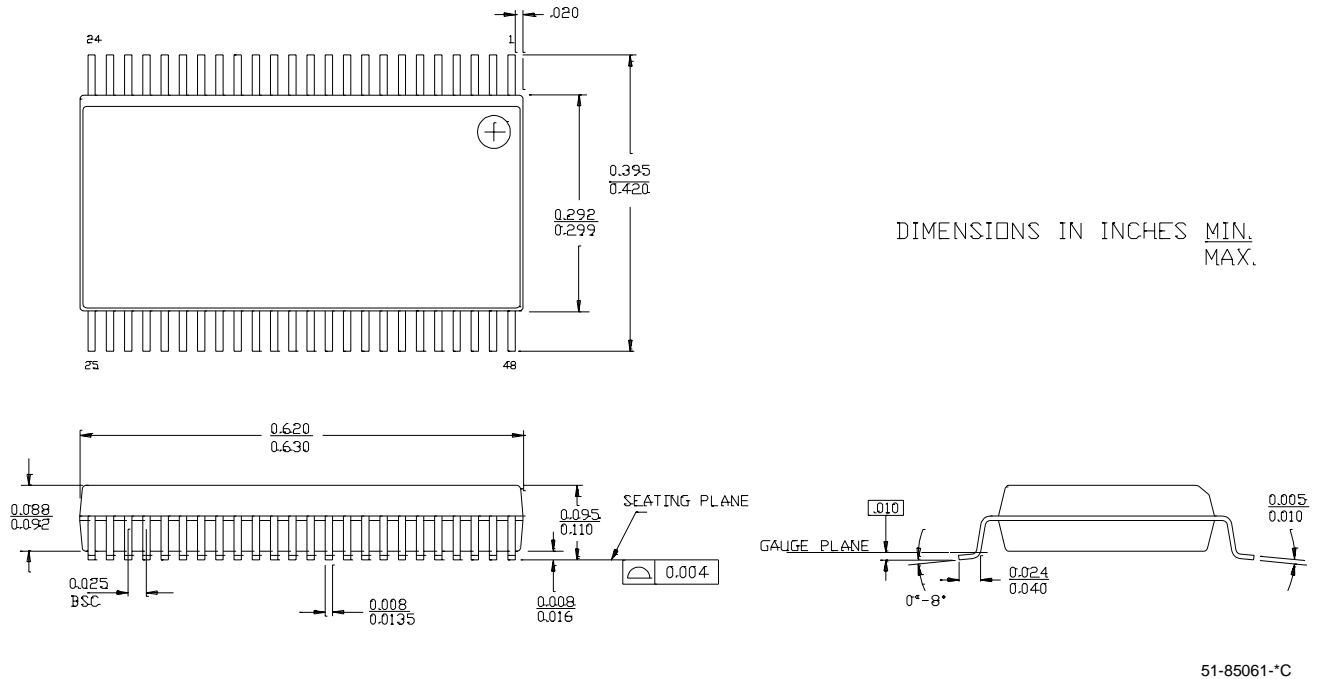
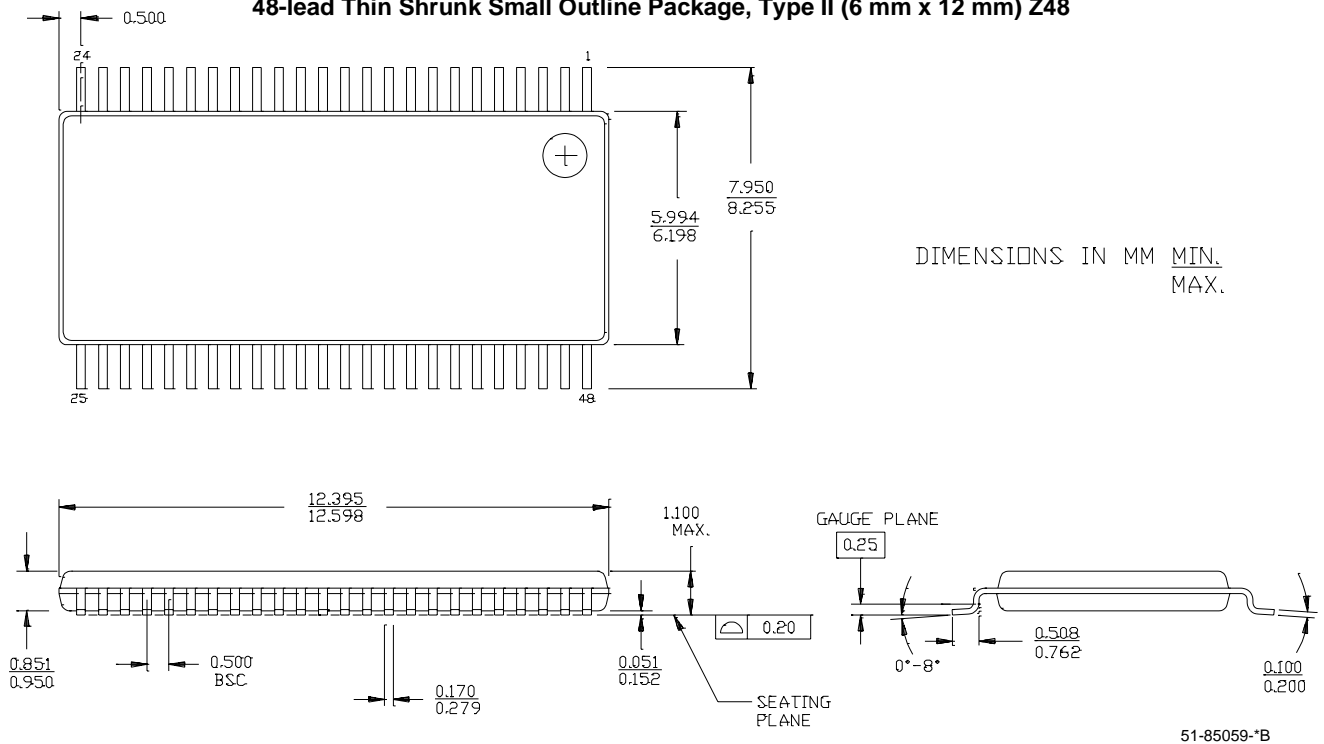

Figure 9. Lumped Load For Single-Ended Output Signals (for AC Parameters Measurement)

Ordering Information

Part Number	Package Type	Product Flow
CY28342OC	48-pin Shrunken Small Outline Package (SSOP)	Commercial 0° to 70°C
CY28342OCT	48-pin Shrunken Small Outline Package (SSOP) – Tape and Reel	Commercial 0° to 70°C
CY28342ZC	48-pin Thin Shrunken Small Outline Package (TSSOP)	Commercial 0° to 70°C
CY28342ZCT	48-pin Thin Shrunken Small Outline Package (TSSOP) – Tape and Reel	Commercial 0° to 70°C

Package Drawing and Dimensions
48-lead Shrunk Small Outline Package O48

48-lead Thin Shrunk Small Outline Package, Type II (6 mm x 12 mm) Z48

Pentium is a registered trademark of Intel Corporation. Dial-a-Frequency and Dial-a-dB are registered trademarks and Dial-a-Ratio and Dial-a-Skew are trademarks of Cypress Semiconductor Corporation. All product and company names mentioned in this document may be the trademarks of their respective holders.



Document History Page

Document Title: CY28342 High-performance SiS645/650 Pentium® 4 Clock Synthesizer				
Document Number: 38-07349				
REV.	ECN NO.	Issue Date	Orig. of Change	Description of Change
**	111854	03/04/02	DMG	New Data Sheet
*A	117644	09/11/02	DMG	Changed the VTTTPWRGD transition logic from LOW to HIGH in page 3. Changed the Power Up default in Byte 9 Bit 3 from 1 to 0 in page 7.