



CYPRESS

CY29972

3.3V, 125-MHz Multi-Output Zero Delay Buffer

Features

- Output frequency up to 125 MHz
- 12 Clock outputs: frequency configurable
- 350 ps max. output-to-output skew
- Configurable output disable
- Two reference clock inputs for dynamic toggling
- Oscillator or crystal reference input
- Spread-spectrum-compatible
- Glitch-free output clocks transitioning
- 3.3V power supply
- Pin-compatible with MPC972
- Industrial temperature range: -40°C to +85°C
- 52-pin TQFP package

Table 1. Frequency Table^[1]

VCO_SEL	FB_SEL2	FB_SEL1	FB_SEL0	F _{VCO}
0	0	0	0	8x
0	0	0	1	12x
0	0	1	0	16x
0	0	1	1	20x
0	1	0	0	16x
0	1	0	1	24x
0	1	1	0	32x
0	1	1	1	40x
1	0	0	0	4x
1	0	0	1	6x
1	0	1	0	8x
1	0	1	1	10x
1	1	0	0	8x
1	1	0	1	12x
1	1	1	0	16x
1	1	1	1	20x

Note:

1. x = the reference input frequency, 200 MHz < F_{VCO} < 480 MHz.

Block Diagram

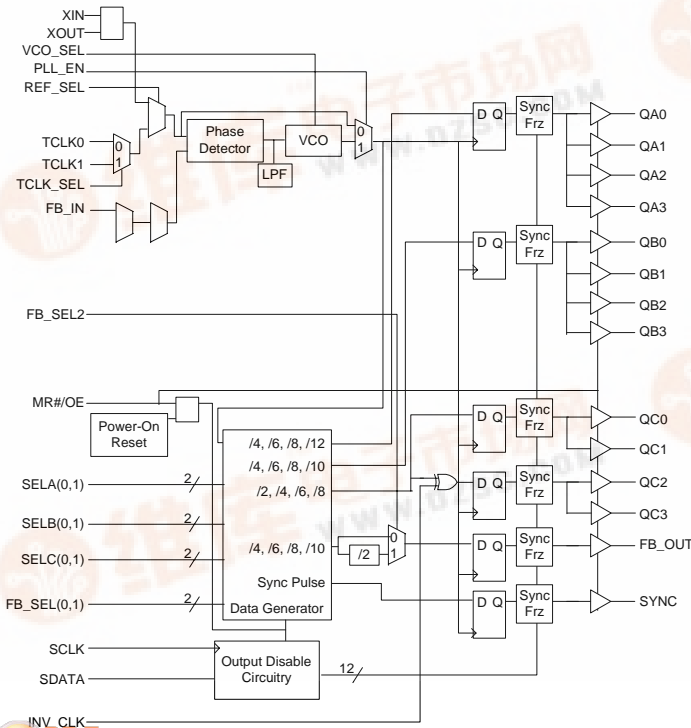

Pin Configuration

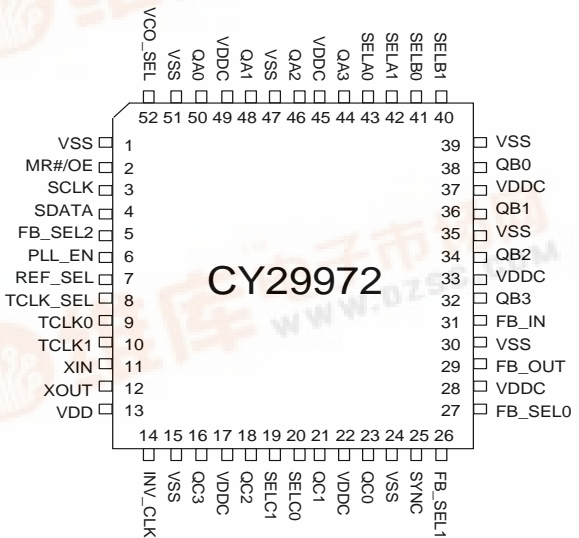

Pin Description^[2]

Pin	Name	PWR	I/O	Type	Description
11	X _{IN}		I		Oscillator Input. Connect to a crystal.
12	X _{OUT}		O		Oscillator Output. Connect to a crystal.
9	T _{CLK0}		I	PU	External Reference/Test Clock Input.
10	T _{CLK1}		I	PU	External Reference/Test Clock Input.
44, 46, 48, 50	QA(3:0)	V _{DDC}	O		Clock Outputs. See <i>Table 2</i> for frequency selections.
32, 34, 36, 38	QB(3:0)	V _{DDC}	O		Clock Outputs. See <i>Table 2</i> for frequency selections.
16, 18, 21, 23	QC(3:0)	V _{DDC}	O		Clock Outputs. See <i>Table 2</i> for frequency selections.
29	FB_OUT	V _{DDC}	O		Feedback Clock Output. Connect to FB_IN for normal operation. The divider ratio for this output is set by FB_SEL(0:2). See <i>Table 1</i> . A bypass delay capacitor at this output will control Input Reference/Output Banks phase relationships.
25	SYNC	V _{DDC}	O		Synchronous Pulse Output. This output is used for system synchronization. The rising edge of the output pulse is in sync with both the rising edges of QA (0:3) and QC(0:3) output clocks regardless of the divider ratios selected.
42, 43	SELA(1,0)		I	PU	Frequency Select Inputs. These inputs select the divider ratio at QA(0:3) outputs. See <i>Table 2</i> .
40, 41	SELB(1,0)		I	PU	Frequency Select Inputs. These inputs select the divider ratio at QB(0:3) outputs. See <i>Table 2</i> .
19, 20	SELC(1,0)		I	PU	Frequency Select Inputs. These inputs select the divider ratio at QC(0:3) outputs. See <i>Table 2</i> .
5, 26, 27	FB_SEL(2:0)		I	PU	Feedback Select Inputs. These inputs select the divide ratio at FB_OUT output. See <i>Table 1</i> .
52	VCO_SEL		I	PU	VCO Divider Select Input. When set low, the VCO output is divided by 2. When set high, the divider is bypassed. See <i>Table 1</i> .
31	FB_IN		I	PU	Feedback Clock Input. Connect to FB_OUT for accessing the PLL.
6	PLL_EN		I	PU	PLL Enable Input. When asserted high, PLL is enabled. And when low, PLL is bypassed.
7	REF_SEL		I	PU	Reference Select Input. When high, the crystal oscillator is selected. And when low, TCLK (0,1) is the reference clock.
8	TCLK_SEL		I	PU	TCLK Select Input. When LOW, TCLK0 is selected and when high TCLK1 is selected.
2	MR#/OE		I	PU	Master Reset/Output Enable Input. When asserted low, resets all of the internal flip-flops and also disables all of the outputs. When pulled high, releases the internal flip-flops from reset and enables all of the outputs.
14	INV_CLK		I	PU	Inverted Clock Input. When set high, QC(2,3) outputs are inverted. When set low, the inverter is bypassed.
3	S _{CLK}		I	PU	Serial Clock Input. Clocks data at SDATA into the internal register.
4	S _{DATA}		I	PU	Serial Data Input. Input data is clocked to the internal register to enable/disable individual outputs. This provides flexibility in power management.
17, 22, 28, 33, 37, 45, 49	V _{DDC}				3.3V power supply for output clock buffers.
13	V _{DD}				3.3V power supply for PLL.
1, 15, 24, 30, 35, 39, 47, 51	V _{SS}				Common ground.

Note:

- A bypass capacitor (0.1 mF) should be placed as close as possible to each positive power (< 0.2"). If these bypass capacitors are not close to the pins, their high-frequency filtering characteristics will be cancelled by the lead inductance of the traces.

Description

The CY29972 has an integrated PLL that provides low skew and low jitter clock outputs for high-performance microprocessors. Three independent banks of four outputs and an independent PLL feedback output (FB_OUT) provide exceptional flexibility for possible output configurations. The PLL is ensured stable operation given that the V_{CO} is configured to run between 200 MHz and 480 MHz. This allows a wide range of output frequencies up to 125 MHz.

The phase detector compares the input reference clock to the external feedback input. For normal operation, the external feedback input (FB_IN) is connected to the feedback output (FB_OUT). The internal V_{CO} is running at multiples of the input reference clock set by FB_SEL(0:2) and VCO_SEL select

inputs (refer to Frequency Table). The V_{CO} frequency is then divided to provide the required output frequencies. These dividers are set by SELA(0,1), SELB(0,1), SELC(0,1) select inputs (see Table 3 below). For situations where the V_{CO} needs to run at relatively low frequencies and hence might not be stable, assert VCO_SEL low to divide the VCO frequency by 2. This will maintain the desired output relationships but will provide an enhanced PLL lock range.

The CY29972 is also capable of providing inverted output clocks. When INV_CLK is asserted HIGH, QC2 and QC3 output clocks are inverted. These clocks could be used as feedback outputs to the CY29972 or a second PLL device to generate early or late clocks for a specific design. This inversion does not affect the output to output skew.

Table 2.

VCO_SEL	SELA1	SELA0	QA	SELB1	SELB0	QB	SELC1	SELC0	QC
0	0	0	VCO/8	0	0	VCO/8	0	0	VCO/4
0	0	1	VCO/12	0	1	VCO/12	0	1	VCO/8
0	1	0	VCO/16	1	0	VCO/16	1	0	VCO/12
0	1	1	VCO/24	1	1	VCO/20	1	1	VCO/16
1	0	0	VCO/4	0	0	VCO/4	0	0	VCO/2
1	0	1	VCO/6	0	1	VCO/6	0	1	VCO/4
1	1	0	VCO/8	1	0	VCO/8	1	0	VCO/6
1	1	1	VCO/12	1	1	VCO/10	1	1	VCO/8

Glitch-Free Output Frequency Transitions

Customarily, when output buffers have their internal counters changed “on the fly,” their output clock periods will:

1. contain short or “runt” clock periods. These are clock cycles in which the cycle(s) are shorter in period than either the old or new frequencies to which the cycles are being transitioned.
2. contain stretched clock periods. These are clock cycles in which the cycle(s) are longer in period than either the old or new frequencies to which the cycles are being transitioned.

This device specifically includes logic to guarantee that runt and stretched clock pulses do not occur if the device logic

levels of any or all of the following pins changed “on the fly” while it is operating: SELA, SELB, SELC, and VCO_SEL.

SYNC Output

In situations where output frequency relationships are not integer multiples of each other, the SYNC output provides a signal for system synchronization. The CY29972 monitors the relationship between the QA and QC output clocks. It provides a LOW-going pulse, one period in duration, one period prior to the coincident rising edges of the QA and QC outputs. The duration and placement of the pulse depend on the higher of the QA and QC output frequencies. The following timing diagram illustrates various waveforms for the SYNC output. Note that the SYNC output is defined for all possible combinations of QA and QC outputs, even though under some relationships the lower frequency clock could be used as a synchro-

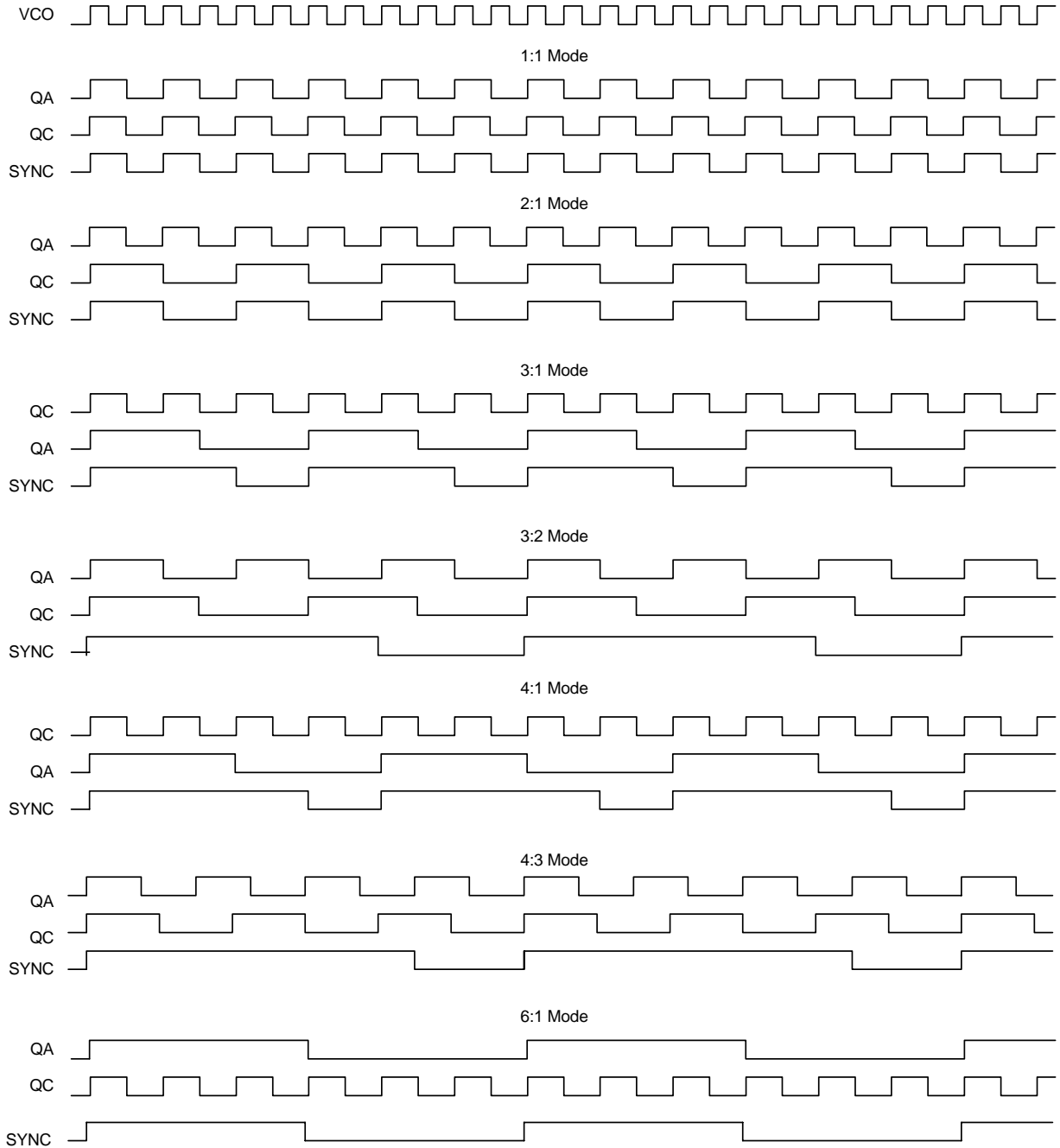

Figure 1. Timing Diagram

Power Management

The individual output enable/freeze control of the CY29972 allows the user to implement unique power management schemes into the design. The outputs are stopped in the logic '0' state when the freeze control bits are activated. The serial input register contains one programmable freeze enable bit for 12 of the 14 output clocks. The QC0 and FB_OUT outputs can not be frozen with the serial port, this avoids any potential lock up situation should an error occur in the loading of the serial

data. An output is frozen when a logic '0' is programmed and enabled when a logic '1' is written. The enabling and freezing of individual outputs is done in such a manner as to eliminate the possibility of partial "runt" clocks.

The serial input register is programmed through the SDATA input by writing a logic '0' start bit followed by 12 NRZ freeze enable bits. The period of each SDATA bit equals the period of the free running SCLK signal. The SDATA is sampled on the rising edge of SCLK.

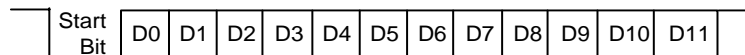

D0-D3 are the control bits for QA0-QA3, respectively
D4-D7 are the control bits for QB0-QB3, respectively
D8-D10 are the control bits for QC1-QC3, respectively
D11 is the control bit for SYNC

Figure 2.

Table 3. Suggested Oscillator Crystal Parameters

Symbol	Characteristic	Min	Typ	Max	Units	Conditions
T _C	Frequency Tolerance			±100	PPM	Note 3
T _S	Frequency Temperature Stability			±100	PPM	(T _A -10 to +60°C) ^[3]
T _A	Aging			5	PPM/Yr	(first 3 years @ 25°C) ^[3]
C _L	Load Capacitance		20	–	pF	The crystal's rated load. ^[3]
R _{ESR}	Effective Series Resistance (ESR)		40	80	Ohms	Note 44

Notes:

3. For best performance and accurate frequencies from this device, It is recommended but not mandatory that the chosen crystal meet or exceed these specifications.
4. Larger values may cause this device to exhibit oscillator start-up problems.

Maximum Ratings ^[5]

Maximum input voltage relative to V_{SS} : $V_{SS} - 0.3V$
 Maximum input voltage relative to V_{DD} : $V_{DD} + 0.3V$
 Storage temperature: $-65 \times C$ to $+150 \times C$
 Operating temperature: $-40 \times C$ to $+85 \times C$
 Maximum ESD protection 2kV
 Maximum power supply: 5.5V
 Maximum input current: ± 20 mA

This device contains circuitry to protect the inputs against damage due to high static voltages or electric field; however, precautions should be taken to avoid application of any voltage higher than the maximum rated voltages to this circuit. For proper operation, V_{IN} and V_{OUT} should be constrained to the range:
 $V_{SS} < (V_{IN} \text{ or } V_{OUT}) < V_{DD}$.
 Unused inputs must always be tied to an appropriate logic voltage level (either V_{SS} or V_{DD}).

DC Parameters $V_{DD} = 2.9V$ to $3.6V$, $V_{DDC} = 3.3V \pm 10\%$, $T_A = -40^\circ C$ to $+85^\circ C$

Parameter	Description	Test Conditions	Min.	Typ.	Max.	Unit
V_{IL}	Input Low Voltage		V_{SS}	–	0.8	V
V_{IH}	Input High Voltage		2.0	–	V_{DD}	V
I_{IL}	Input Low Current ^[6]			–	–120	μA
I_{IH}	Input High Current				10	μA
V_{OL}	Output Low Voltage ^[7]	$I_{OL} = 20mA$			0.5	V
V_{OH}	Output High Voltage ^[7]	$I_{OH} = -20mA$	2.4			V
I_{DDQ}	Quiescent Supply Current		–	10	15	mA
I_{DDA}	PLL Supply Current	V_{DD} only		15	20	mA
I_{DD}	Dynamic Supply Current	QA and QB @ 60 MHz, QC @ 120 MHz, CL = 30 pF		225		mA
		QA and QB @ 25 MHz, QC @ 50 MHz, CL = 30 pF		125		
C_{IN}	Input Pin Capacitance		–	4	–	pF

Notes:

5. **Multiple Supplies:** The voltage on any input or I/O pin cannot exceed the power pin during power-up. Power supply sequencing is NOT required.
6. Inputs have pull-up/pull-down resistors that effect input current.
7. Driving series or parallel terminated 50 Ω (or 50 Ω to $V_{DD/2}$) transmission lines.

AC Parameters $V_{DD} = 2.9V$ to $3.6V$, $V_{DDC} = 3.3V \pm 10\%$, $T_A = -40^\circ C$ to $+85^\circ C$ ^[8]

Parameter	Description	Conditions	Min	Typ	Max	Unit	
Tr / Tf	TCLK Input Rise/Fall				3.0	ns	
Fref	Reference Input Frequency		Note 9		Note 9	MHz	
Fxtal	Crystal Oscillator Frequency	see Table 3	10		25	MHz	
FrefDC	Reference Input Duty Cycle		25		75	%	
Fvco	PLL VCO Lock Range		200		480	MHz	
Tlock	Maximum PLL Lock Time				10	ms	
Tr / Tf	Output Clocks Rise / Fall Time ^[10]	0.8V to 2.0V	0.15		1.2	ns	
Fout	Maximum Output Frequency	Q (+2)	–		125	MHz	
		Q (+4)			120		
		Q (+6)			80		
		Q (+8)			60		
FoutDC	Output Duty Cycle ^[10]		TCYCLE/2 – 750		TCYCLE/2 + 750	ps	
tpZL, tpZH	Output Enable Time ^[10] (all outputs)		2		10	ns	
tpLZ, tpHZ	Output Disable Time ^[10] (all outputs)		2		8	ns	
TCCJ	Cycle to Cycle Jitter ^[10] (peak to peak)			± 100		ps	
TSKEW	Any Output to Any Output Skew ^[10,11]			250	350	ps	
Tpd	Propagation Delay ^[11,12]	T_{CLK0}	QFB = (+8)	–270	130	530	ps
		T_{CLK1}		–330	70	470	

Notes:

8. Parameters are guaranteed by design and characterization. Not 100% tested in production.
9. Maximum and minimum input reference is limited by VCO lock range.
10. Outputs loaded with 30 pF each.
11. 50W transmission line terminated into $V_{DD/2}$.
12. Tpd is specified for a 50 MHz input reference. Tpd does not include jitter.

Ordering Information

Part Number	Package Type	Production Flow
CY29972AI	52-pin TQFP	Industrial, -40°C to +85°C

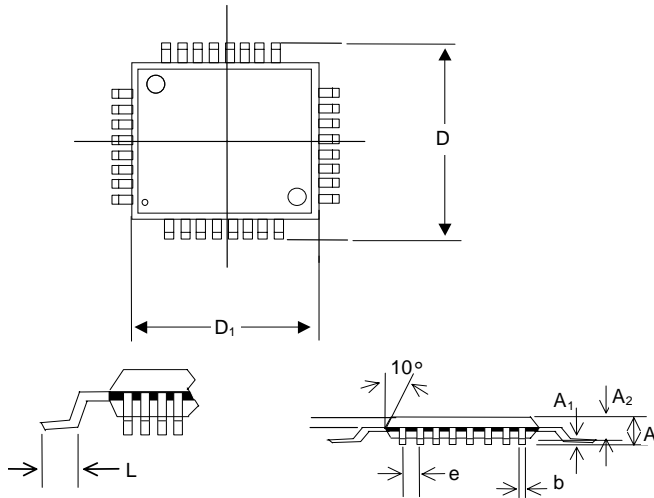
Package Drawing and Dimensions

Symbol	Inches			Millimeters		
	Min.	Nom.	Max.	Min.	Nom.	Max.
A	-	-	0.047	-	-	1.20
A1	0.002	-	0.006	0.05	-	0.15
A2	0.037	-	0.041	0.95	-	1.05
D	-	0.0472	-	-	12.00	-
D1	-	0.394	-	-	10.00	-
b	0.009	-	0.015	0.22	-	0.38
e	0.026 BSC			0.65 BSC		
L	0.018	-	0.030	0.45	-	0.75

All product and company names are the trademarks of their respective holders.



Revision History

Document Title: 3.3V, 125 MHz Multi-Output Zero Delay Buffer				
Document Number: 38-07290				
REV.	ECN NO.	Issue Date	Orig. of Change	Description of Change
**	111101	02/07/02	BRK	New Data Sheet
*A	122882	12/22/02	RBI	Added power up requirements to Maximum Ratings