



**Integrated
Circuit
Systems, Inc.**

ICS9248-146

Frequency Generator & Integrated Buffers for Celeron & PII/III™

Recommended Application:

Single chip clock solution for SIS630S chipsets.

Output Features:

- 3- CPUs @ 2.5V
- 13 - SDRAM @ 3.3V
- 6- PCI @ 3.3V,
- 2 - AGP @ 3.3V
- 1- 48MHz, @3.3V fixed.
- 1- 24/48MHz, @3.3V selectable by I²C (Default is 24MHz)
- 2- REF @ 3.3V, 14.318MHz.

Features:

- Up to 166MHz frequency support
- Support FS0-FS3 trapping status bit for I²C read back.
- Support power management: CPU, PCI, SDRAM stops and Power down Mode form I²C programming.
- Spread spectrum for EMI control (0 to -0.5%, ± 0.25%).
- Uses external 14.318MHz crystal

Skew Specifications:

- CPU - CPU: < 175ps
- SDRAM - SDRAM < 250ps (except SDRAM12)
- PCI - PCI: < 500ps
- CPU (early) - PCI: 1-4ns (typ. 2ns)

Pin Configuration

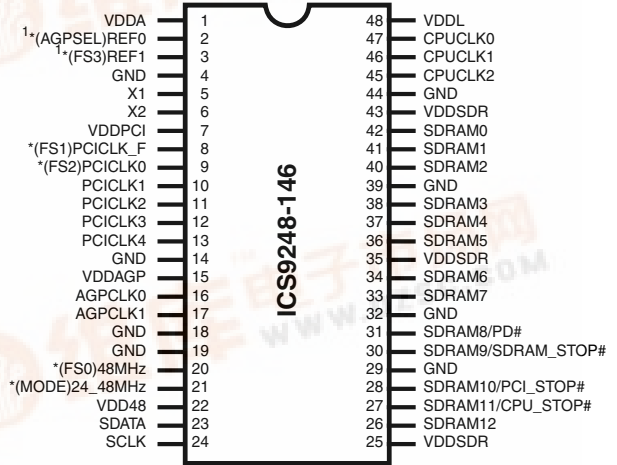

48-Pin 300mil SSOP

* These inputs have a 120K pull down to GND.
¹ These are double strength.

Block Diagram

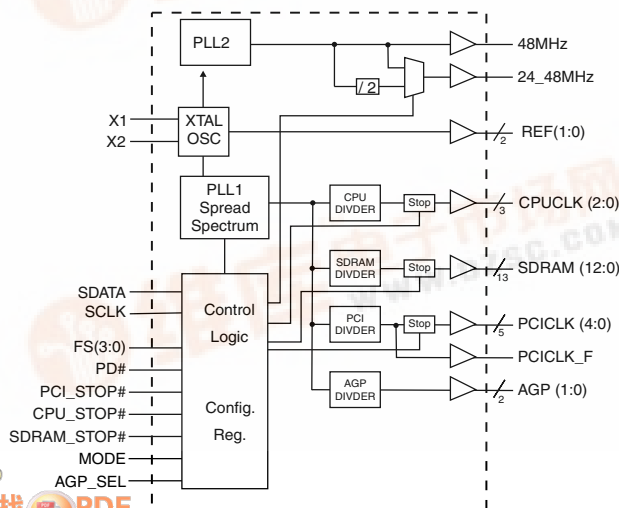

Functionality

FS3	FS2	FS1	FS0	CPU	SDRAM	PCICLK	AGP SEL = 0	AGP SEL = 1
0	0	0	0	66.67	66.67	33.33	66.67	50.00
0	0	0	1	100.00	100.00	33.33	66.67	50.00
0	0	1	0	166.67	166.67	33.33	66.66	55.56
0	0	1	1	133.33	133.33	33.33	66.67	50.00
0	1	0	0	66.67	100.00	33.33	66.67	50.00
0	1	0	1	100.00	66.67	33.33	66.67	50.00
0	1	1	0	100.00	133.33	33.33	66.67	50.00
0	1	1	1	133.33	100.00	33.33	66.67	50.00
1	0	0	0	112.00	112.00	33.60	67.20	56.00
1	0	0	1	124.00	124.00	31.00	62.00	46.50
1	0	1	0	138.00	138.00	34.50	69.00	51.75
1	0	1	1	150.00	150.00	30.00	60.00	50.00
1	1	0	0	66.67	133.33	33.33	66.67	50.00
1	1	0	1	100.00	150.00	30.00	60.00	50.00
1	1	1	0	150.00	100.00	30.00	60.00	50.00
1	1	1	1	160.00	120.00	30.00	60.00	48.00

ICS9248-146



General Description

The **ICS9248-146** is the single chip clock solution for Desktop/Notebook designs using the SIS 630S style chipset. It provides all necessary clock signals for such a system.

Spread spectrum may be enabled through I²C programming. Spread spectrum typically reduces system EMI by 8dB to 10dB. This simplifies EMI qualification without resorting to board design iterations or costly shielding. The ICS9248-146 employs a proprietary closed loop design, which tightly controls the percentage of spreading over process and temperature variations.

Serial programming I²C interface allows changing functions, stop clock programming and frequency selection.

Power Groups

Analog

VDDA = X1, X2, Core, PLL
VDD48 = 48MHz, 24MHz, fixed PLL

Digital

VDDPCI=PCICLK_F, PCICLK
VDDSDR = SDRAM
VDDAGP=AGP, REF

MODE Pin Power Management Control Input

MODE Pin 21	Pin 27	Pin 28	Pin 30	Pin 31
0	SDRAM11	SDRAM10	SDRAM9	SDRAM8
1	CPU_STOP#	PCI_STOP#	SDRAM_STOP#	PD#

Pin Configuration

PIN NUMBER	PIN NAME	TYPE	DESCRIPTION
1, 7, 15, 22, 25, 35, 43	VDD	PWR	3.3V Power supply for SDRAM output buffers, PCI output buffers, reference output buffers and 48MHz output
2	AGPSEL	IN	AGP frequency select pin.
	REF0	OUT	14.318 MHz reference clock.
3	FS3	IN	Frequency select pin.
	REF1	OUT	14.318 MHz reference clock.
4, 14, 18, 19, 29, 32, 39, 44	GND	PWR	Ground pin for 3V outputs.
5	X1	IN	Crystal input, nominally 14.318MHz.
6	X2	OUT	Crystal output, nominally 14.318MHz.
8	FS1	IN	Frequency select pin.
	PCICLK_F	OUT	PCI clock output, not affected by PCI_STOP#
9	FS2	IN	Frequency select pin.
	PCICLK0	OUT	PCI clock output.
13, 12, 11, 10	PCICLK (4:1)	OUT	PCI clock outputs.
17, 16,	AGP (1:0)	OUT	AGP outputs defined as 2X PCI. These may not be stopped.
20	FS0	IN	Frequency select pin.
	48MHz	OUT	48MHz output clock
21	MODE	IN	Pin 27, 28, 30, & 31 function select pins 0=Desktop 1=Mobile mode
	24_48MHz	OUT	Clock output for super I/O/USB default is 24MHz
23	SDATA	I/O	Data pin for I ² C circuitry 5V tolerant
24	SCLK	IN	Clock pin of I ² C circuitry 5V tolerant
27	CPU_STOP#	IN	Stops all PCICLKs besides the PCICLK_F clocks at logic 0 level, when input is low and MODE pin is in Mobile mode
	SDRAM11	OUT	SDRAM clock output
28	PCI_STOP#	IN	Stops all CPUCLKs clocks at logic 0 level, when input is low and MODE pin is in Mobile mode
	SDRAM10	OUT	SDRAM clock output
30	SDRAM9	OUT	SDRAM clock output
	SDRAM_STOP#	IN	Stops all SDRAM clocks at logic 0 level, when input is low and MODE pin is in Mobile mode
31	PD#	IN	Asynchronous active low input pin used to power down the device into a low power state. The internal clocks are disabled and the VCO and the crystal are stopped. The latency of the power down will not be greater than 3ms.
	SDRAM8	OUT	SDRAM clock output
26 33, 34, 36, 37, 38, 40, 41, 42	SDRAM (12, 7:0)	OUT	SDRAM clock outputs
45, 46, 47	CPUCLK (2:0)	OUT	CPU clock outputs.
48	VDDL	PWR	Power pin for the CPUCLKs. 2.5V



Serial Configuration Command Bitmap

Byte0: Functionality and Frequency Select Register (default = 0)

Bit	Description										PWD
Bit 2	Bit 7	Bit 6	Bit 5	Bit 4							Spread Percentage
	FS3	FS2	FS1	FS0	CPU	SDRAM	PCI	AGP SEL = 0	AGP SEL = 1		
0	0	0	0	0	66.67	66.67	33.33	66.67	50.00	0 to -0.5% Down Spread	
0	0	0	0	1	100.00	100.00	33.33	66.67	50.00	0 to -0.5% Down Spread	
0	0	0	1	0	166.67	166.67	33.33	66.66	55.56	+/- 0.25% Center Spread	
0	0	0	1	1	133.33	133.33	33.33	66.67	50.00	0 to -0.5% Down Spread	
0	0	1	0	0	66.67	100.00	33.33	66.67	50.00	0 to -0.5% Down Spread	
0	0	1	0	1	100.00	66.67	33.33	66.67	50.00	0 to -0.5% Down Spread	
0	0	1	1	0	100.00	133.33	33.33	66.67	50.00	0 to -0.5% Down Spread	
0	0	1	1	1	133.33	100.00	33.33	66.67	50.00	0 to -0.5% Down Spread	
0	1	0	0	0	112.00	112.00	33.60	67.20	56.00	+/- 0.25% Center Spread	
0	1	0	0	1	124.00	124.00	31.00	62.00	46.50	+/- 0.25% Center Spread	
0	1	0	1	0	138.00	138.00	34.50	69.00	51.75	+/- 0.25% Center Spread	
0	1	0	1	1	150.00	150.00	30.00	60.00	50.00	+/- 0.25% Center Spread	
0	1	1	0	0	66.67	133.33	33.33	66.67	50.00	0 to -0.5% Down Spread	
0	1	1	0	1	100.00	150.00	30.00	60.00	50.00	+/- 0.25% Center Spread	
0	1	1	1	0	150.00	100.00	30.00	60.00	50.00	+/- 0.25% Center Spread	
0	1	1	1	1	160.00	120.00	30.00	60.00	48.00	+/- 0.25% Center Spread	
1	0	0	0	0	103.00	103.00	34.33	68.67	50.00	+/- 0.25% Center Spread	
1	0	0	0	1	100.30	100.30	33.43	66.87	50.00	+/- 0.25% Center Spread	
1	0	0	1	0	200.00	200.00	33.33	66.67	50.00	+/- 0.25% Center Spread	
1	0	0	1	1	133.73	133.73	33.43	66.87	50.15	+/- 0.25% Center Spread	
1	0	1	0	0	103.00	137.33	34.33	68.67	51.50	+/- 0.25% Center Spread	
1	0	1	0	1	137.33	103.00	34.33	68.67	51.50	+/- 0.25% Center Spread	
1	0	1	1	0	66.87	100.30	33.43	66.87	50.15	+/- 0.25% Center Spread	
1	0	1	1	1	133.73	100.30	33.43	66.87	50.15	+/- 0.25% Center Spread	
1	1	0	0	0	110.00	110.00	33.00	66.00	55.00	+/- 0.25% Center Spread	
1	1	0	0	1	115.00	115.00	34.50	69.00	57.50	+/- 0.25% Center Spread	
1	1	0	1	0	140.00	140.00	35.00	70.00	52.50	+/- 0.25% Center Spread	
1	1	0	1	1	101.50	101.50	33.83	67.67	50.00	+/- 0.25% Center Spread	
1	1	1	0	0	100.30	133.73	33.43	66.87	50.15	+/- 0.25% Center Spread	
1	1	1	0	1	105.00	140.00	35.00	70.00	52.50	+/- 0.25% Center Spread	
1	1	1	1	0	105.00	157.50	31.50	63.00	52.50	+/- 0.25% Center Spread	
1	1	1	1	1	135.33	101.50	33.83	67.67	50.75	+/- 0.25% Center Spread	
Bit 3	0 - Frequency is selected by hardware select, Latched Inputs 1 - Frequency is selected by Bit , 2 7:4										0
Bit 1	0 - Normal 1 - Spread Spectrum Enabled										1
Bit 0	0 - Running 1- Tristate all outputs										0

Note1:

Default at power-up will be for latched logic inputs to define frequency, as displayed by Bit 3.

Note: PWD = Power-Up Default

ICS9248-146



Byte 1: CPU, Active/Inactive Register (1= enable, 0 = disable)

BIT	PIN#	PWD	DESCRIPTION
Bit 7	-	1	Sel24_48 (1:24MHz, 0:48MHz)
Bit 6	-	1	Reserved
Bit 5	-	1	Reserved
Bit 4	-	1	Reserved
Bit 3	47	1	CPUCLK0
Bit 2	46	1	CPUCLK1
Bit 1	45	1	CPUCLK2
Bit 0	-	1	Reserved

Byte 2: PCI, Active/Inactive Register (1= enable, 0 = disable)

BIT	PIN#	PWD	DESCRIPTION
Bit 7	-	1	Reserved
Bit 6	-	1	Reserved
Bit 5	13	1	PCICLK4
Bit 4	12	1	PCICLK3
Bit 3	11	1	PCICLK2
Bit 2	10	1	PCICLK1
Bit 1	9	1	PCICLK0
Bit 0	8	1	PCICLK_F

Byte 3: SDRAM, Active/Inactive Register (1= enable, 0 = disable)

BIT	PIN#	PWD	DESCRIPTION
Bit 7	33	1	SDRAM7
Bit 6	34	1	SDRAM6
Bit 5	36	1	SDRAM5
Bit 4	37	1	SDRAM4
Bit 3	38	1	SDRAM3
Bit 2	40	1	SDRAM2
Bit 1	41	1	SDRAM1
Bit 0	42	1	SDRAM0

Byte 4: SDRAM , Active/Inactive Register (1= enable, 0 = disable)

BIT	PIN#	PWD	DESCRIPTION
Bit 7	-	1	Reserved
Bit 6	21	1	24_48MHz
Bit 5	20	1	48MHz
Bit 4	26	1	SDRAM12
Bit 3	27	1	SDRAM11
Bit 2	28	1	SDRAM10
Bit 1	30	1	SDRAM9
Bit 0	31	1	SDRAM8

Byte 5: AGP, Active/Inactive Register (1= enable, 0 = disable)

BIT	PIN#	PWD	DESCRIPTION
Bit 7	-	X	FS3 (Readback)
Bit 6	-	X	FS2 (Readback)
Bit 5	-	X	FS1 (Readback)
Bit 4	-	X	FS0 (Readback)
Bit 3	2	1	REF1
Bit 2	3	1	REF0
Bit 1	17	1	AGPCLK1
Bit 0	16	1	AGPCLK0

Notes:

1. Inactive means outputs are held LOW and are disabled from switching.
2. Latched Frequency Selects (FS#) will be inverted logic load of the input frequency select pin conditions.



Byte 6: Control , Active/Inactive Register
(1= enable, 0 = disable)

BIT	PIN#	PWD	DESCRIPTION
Bit7	2,3	0	REF strength 0=1X, 1=2X
Bit6	45	0	CPUCLK2 - Stop - Control 0=CPU_STOP# will control CPUCLK2, 1=CPUCLK2 is free running even if CPU_STOP# is low
Bit5	-	X	AGPSEL (Readback)
Bit4	-	X	MODE (Readback)
Bit3	-	X	CPU_STOP# (Readback)
Bit2	-	X	PCI_STOP# (Readback)
Bit1	-	X	SDRAM_STOP# (Readback)
Bit0	-	0	AGP Speed Toggle 0=AGPSEL (pin2) will be determined by latch input setting, 1=AGPSEL will be opposite of latch input setting

Byte 7: Vendor ID Register
(1= enable, 0 = disable)

BIT	PIN#	PWD	DESCRIPTION
Bit 7	-	0	Reserved
Bit 6	-	0	Reserved
Bit 5	-	1	Reserved
Bit 4	-	0	Reserved
Bit 3	-	1	Reserved
Bit 2	-	0	Reserved
Bit 1	-	0	Reserved
Bit 0	-	1	Reserved

ICS9248-146



Absolute Maximum Ratings

Supply Voltage 5.5 V
 Logic Inputs GND -0.5 V to V_{DD} +0.5 V
 Ambient Operating Temperature 0°C to +70°C
 Case Temperature..... 115°C
 Storage Temperature -65°C to +150°C

Stresses above those listed under *Absolute Maximum Ratings* may cause permanent damage to the device. These ratings are stress specifications only and functional operation of the device at these or any other conditions above those listed in the operational sections of the specifications is not implied. Exposure to absolute maximum rating conditions for extended periods may affect product reliability.

Electrical Characteristics - Input/Supply/Common Output Parameters

TA = 0 - 70° C; Supply Voltage VDD = 3.3 V +/-5% VDDL = 2.5 V +/-5% (unless otherwise stated)

PARAMETER	SYMBOL	CONDITIONS	MIN	TYP	MAX	UNITS
Input High Voltage	V _{IH}		2		V _{DD} +0.3	V
Input Low Voltage	V _{IL}		V _{SS} -0.3		0.8	V
Supply Current	I _{DD}	C _L =30 pF, CPU @ 66, 100 MHz		390	400	mA
Power Down	PD			300	600	µA
Input frequency	F _i	V _{DD} = 3.3 V;	12	14.318	16	MHz
Input Capacitance ¹	C _{IN}	Logic Inputs			5	pF
	C _{INX}	X1 & X2 pins	27		45	pF
Transition Time	T _{trans}	To 1st crossing of target Freq.			3	
Settling Time	T _S	From 1st crossing to 1% target Freq.				
Clk Stabilization ¹	T _{STAB}	From V _{DD} = 3.3 V to 1% target Freq.			3	ms
Skew	T _{CPU-PCI}	CPU V _T = 1.5 V PCI V _T =1.25V	1	1.9	4	ns
Skew	T _{CPU-SDRAM}	CPU V _T = 1.5 V SDRAM V _T =1.25	-500	-300	0	ps

¹ Guaranteed by design, not 100% tested in production.



Electrical Characteristics - CPU

T_A = 0 - 70C; V_{DDL} = 2.5 V +/-5%; VDDL = 2.5 V +/-5%; C_L = 10-20 pF (unless otherwise specified)

PARAMETER	SYMBOL	CONDITIONS	MIN	TYP	MAX	UNITS
Output Impedance ¹	R _{DSP2B}	V _O = V _{DD} *(0.5)	10		20	Ω
Output Impedance ¹	R _{DSN2B}	V _O = V _{DD} *(0.5)	10		20	Ω
Output High Voltage	V _{OH2B}	I _{OH} = -12.0 mA	2			V
Output Low Voltage	V _{OL2B}	I _{OL} = 12 mA			0.4	V
Output High Current	I _{OH2B}	V _{OH} = 1.7 V			-19	mA
Output Low Current	I _{OL2B}	V _{OL} = 0.7 V	19			mA
Rise Time ¹	t _{r2B}	V _{OL} = 0.4 V, V _{OH} = 2.0 V	0.4	1.2	1.6	ns
Fall Time ¹	t _{f2B}	V _{OH} = 2.0 V, V _{OL} = 0.4 V	0.4	1.1	1.6	ns
Duty Cycle ¹	d _{t2B}	V _T = 1.25 V	45	46.9	55	%
Skew window ^{0:1}	t _{sk2B}	V _T = 1.25 V		43	175	ps
Skew window ^{0:2}	t _{sk2B}	V _T = 1.25 V		142	375	ps
Jitter, Cycle-to-cycle ¹	t _{jyc-cyc}	V _T = 1.25 V, CPU=66 MHz		177	250	ps

¹Guaranteed by design, not 100% tested in production.

Electrical Characteristics - 24-48MHz

T_A = 0 - 70C; V_{DD} = 3.3 V +/-5%; VDDL = 2.5 V +/-5%; C_L = 10-20 pF (unless otherwise specified)

PARAMETER	SYMBOL	CONDITIONS	MIN	TYP	MAX	UNITS
Output Impedance	R _{DSP5B} ¹	V _O = V _{DD} *(0.5)	20		60	Ω
Output Impedance	R _{DSN5B} ¹	V _O = V _{DD} *(0.5)	20		60	Ω
Output High Voltage	V _{OH15}	I _{OH} = -14 mA	2.4			V
Output Low Voltage	V _{OL5}	I _{OL} = 6.0 mA			0.4	V
Output High Current	I _{OH5}	V _{OH} = 2.0 V			-20	mA
Output Low Current	I _{OL5}	V _{OL} = 0.8 V	10			mA
Rise Time ¹	t _{r5}	V _{OL} = 0.4 V, V _{OH} = 2.4 V	0.4	1.45	4	ns
Fall Time ¹	t _{f5}	V _{OH} = 2.4 V, V _{OL} = 0.4 V	0.4	1.5	4	ns
Duty Cycle ¹	d _{t5}	V _T = 1.5 V	45	52.5	55	%
Jitter	t _{cycle to cycle}	V _T = 1.5 V		210	500	ps

¹Guaranteed by design, not 100% tested in production.



Electrical Characteristics - PCI

$T_A = 0 - 70^\circ\text{C}$; $V_{DD} = 3.3 \text{ V} \pm 5\%$; $V_{DDL} = 2.5 \text{ V} \pm 5\%$; $C_L = 10\text{-}30 \text{ pF}$ (unless otherwise specified)

PARAMETER	SYMBOL	CONDITIONS	MIN	TYP	MAX	UNITS
Output Impedance	R_{DSP1B}^1	$V_O = V_{DD} \cdot (0.5)$	12		55	Ω
Output Impedance	R_{DSN1B}^1	$V_O = V_{DD} \cdot (0.5)$	12		55	Ω
Output High Voltage	V_{OH1}	$I_{OH} = -1 \text{ mA}$	2.4			V
Output Low Voltage	V_{OL1}	$I_{OL} = 1 \text{ mA}$			0.55	V
Output High Current	I_{OH1}	$V_{OH @ MIN} = 1.0 \text{ V}$			-29	mA
Output Low Current	I_{OL1}	$V_{OL @ MIN} = 1.95 \text{ V}$	29			mA
Rise Time ¹	t_{r1}	$V_{OL} = 0.4 \text{ V}, V_{OH} = 2.4 \text{ V}$	0.5	2.3	2.5	ns
Fall Time ¹	t_{f1}	$V_{OH} = 2.4 \text{ V}, V_{OL} = 0.4 \text{ V}$	0.5	2.3	2.5	ns
Duty Cycle ¹	d_{t1}	$V_T = 1.5 \text{ V}$	45	51.2	55	%
Skew window ¹	t_{sk1}	$V_T = 1.5 \text{ V}$		108	500	ps
Jitter, Cycle-to-cycle ¹	$t_{jyc-cyc1}$	$V_T = 1.5 \text{ V}$		353	500	ps

¹Guaranteed by design, not 100% tested in production.

Electrical Characteristics - SDRAM

$T_A = 0 - 70^\circ\text{C}$; $V_{DD} = 3.3 \text{ V} \pm 5\%$; $V_{DDL} = 2.5 \text{ V} \pm 5\%$; $C_L = 20\text{-}30 \text{ pF}$ (unless otherwise specified)

PARAMETER	SYMBOL	CONDITIONS	MIN	TYP	MAX	UNITS
Output Impedance	R_{DSP3B}^1	$V_O = V_{DD} \cdot (0.5)$	10		24	Ω
Output Impedance	R_{DSN3B}^1	$V_O = V_{DD} \cdot (0.5)$	10		24	Ω
Output High Voltage	V_{OH3}	$I_{OH} = -18 \text{ mA}$	2.4			V
Output Low Voltage	V_{OL3}	$I_{OL} = 9.4 \text{ mA}$			0.4	V
Output High Current	I_{OH3}	$V_{OH} = 2.0 \text{ V}$			-46	mA
Output Low Current	I_{OL3}	$V_{OL} = 0.8 \text{ V}$				mA
Rise Time ¹	t_{r3}	$V_{OL} = 0.4 \text{ V}, V_{OH} = 2.4 \text{ V}$		0.8	1.6	ns
Fall Time ¹	t_{f3}	$V_{OH} = 2.4 \text{ V}, V_{OL} = 0.4 \text{ V}$		0.8	1.6	ns
Duty Cycle ¹	d_{t3}	$V_T = 1.5 \text{ V}$	45	48.5	55	%
Skew window ^{1(0:11)}	t_{sk3}	$V_T = 1.5 \text{ V}$		192	250	ps
Skew window ^{1(0:12)}	t_{sk3}	$V_T = 1.5 \text{ V}$		290	500	ps
Jitter, Cycle-to-cycle ¹	$t_{jyc-cyc3}$	$V_T = 1.5 \text{ V}, \text{CPU} = 66, 100, 133 \text{ MHz}$		173	250	ps

¹Guaranteed by design, not 100% tested in production.



Electrical Characteristics - AGP

T_A = 0 - 70C; V_{DD}=3.3V +/-5%; C_L = 20 pF (unless otherwise specified)

PARAMETER	SYMBOL	CONDITIONS	MIN	TYP	MAX	UNITS
Output Impedance	R _{DSP4B} ¹	V _O =V _{DD} *(0.5)	12		55	Ω
Output Impedance	R _{D5N4B} ¹	V _O =V _{DD} *(0.5)	12		55	Ω
Output High Voltage	V _{OH4B}	I _{OH} = -18 mA	2			V
Output Low Voltage	V _{OL4B}	I _{OL} = 18 mA			0.4	V
Output High Current	I _{OH4B}	V _{OH} = 2.0 V			-19	mA
Output Low Current	I _{OL4B}	V _{OL} = 0.8 V	19			mA
Rise Time ¹	t _{r4B}	V _{OL} = 0.4 V, V _{OH} = 2.4 V	0.5	1.5	2	ns
Fall Time ¹	t _{f4B}	V _{OH} = 2.4 V, V _{OL} = 0.4 V	0.5	1.6	2	ns
Duty Cycle ¹	d _{t4B}	V _T = 1.5 V	45	52.3	55	%
Skew window1	t _{sk} ¹	V _T = 1.5 V		55.5	175	ps
Jitter Cyc-Cyc	t _{jcyc-cyc} ¹	V _T = 1.5 V		239	500	ps

¹Guaranteed by design, not 100% tested in production.

Electrical Characteristics - REF

T_A = 0 - 70° C; V_{DD} = 3.3 V +/-5%;V_{DDL} = 2.5 V +/-5%; CL = 20 pF (unless otherwise stated)

PARAMETER	SYMBOL	CONDITIONS	MIN	TYP	MAX	UNITS
Output High Voltage	V _{OH5}	I _{OH} = -12 mA	2.4			V
Output Low Voltage	V _{OL5}	I _{OL} = 9 mA			0.4	V
Output High Current	I _{OH5}	V _{OH} = 2.0 V			-22	mA
Output Low Current	I _{OL5}	V _{OL} = 0.8 V	16			mA
Rise Time ¹	t _{r5}	V _{OL} = 0.4 V, V _{OH} = 2.4 V		1.8	4	ns
Fall Time ¹	t _{f5}	V _{OH} = 2.4 V, V _{OL} = 0.4 V		1.9	4	ns
Duty Cycle ¹	d _{t5}	V _T = 50%	45	54.5	55	%

¹Guaranteed by design, not 100% tested in production.



General I²C serial interface information

The information in this section assumes familiarity with I²C programming.
For more information, contact ICS for an I²C programming application note.

How to Write:

- Controller (host) sends a start bit.
- Controller (host) sends the write address D2_(H)
- ICS clock will *acknowledge*
- Controller (host) sends a dummy command code
- ICS clock will *acknowledge*
- Controller (host) sends a dummy byte count
- ICS clock will *acknowledge*
- Controller (host) starts sending first byte (Byte 0) through byte 6
- ICS clock will *acknowledge* each byte *one at a time*.
- Controller (host) sends a Stop bit

How to Write:	
Controller (Host)	ICS (Slave/Receiver)
Start Bit	
Address D2 _(H)	
	ACK
Dummy Command Code	
	ACK
Dummy Byte Count	
	ACK
Byte 0	
	ACK
Byte 1	
	ACK
Byte 2	
	ACK
Byte 3	
	ACK
Byte 4	
	ACK
Byte 5	
	ACK
Byte 6	
	ACK
Byte 7	
	ACK
Stop Bit	

How to Read:

- Controller (host) will send start bit.
- Controller (host) sends the read address D3_(H)
- ICS clock will *acknowledge*
- ICS clock will send the *byte count*
- Controller (host) acknowledges
- ICS clock sends first byte (*Byte 0*) through *byte 7*
- Controller (host) will need to acknowledge each byte
- Controller (host) will send a stop bit

How to Read:	
Controller (Host)	ICS (Slave/Receiver)
Start Bit	
Address D3 _(H)	
	ACK
	Byte Count
ACK	
	Byte 0
ACK	
	Byte 1
ACK	
	Byte 2
ACK	
	Byte 3
ACK	
	Byte 4
ACK	
	Byte 5
ACK	
	Byte 6
ACK	
	Byte 7
Stop Bit	

Notes:

1. The ICS clock generator is a slave/receiver, I²C component. It can read back the data stored in the latches for verification. **Read-Back will support Intel PIIX4 "Block-Read" protocol.**
2. The data transfer rate supported by this clock generator is 100K bits/sec or less (standard mode)
3. The input is operating at 3.3V logic levels.
4. The data byte format is 8 bit bytes.
5. To simplify the clock generator I²C interface, the protocol is set to use only "**Block-Writes**" from the controller. The bytes must be accessed in sequential order from lowest to highest byte with the ability to stop after any complete byte has been transferred. The Command code and Byte count shown above must be sent, but the data is ignored for those two bytes. The data is loaded until a Stop sequence is issued.
6. At power-on, all registers are set to a default condition, as shown.



Shared Pin Operation - Input/Output Pins

The I/O pins designated by (input/output) on the ICS9248-146 serve as dual signal functions to the device. During initial power-up, they act as input pins. The logic level (voltage) that is present on these pins at this time is read and stored into a 5-bit internal data latch. At the end of Power-On reset, (see AC characteristics for timing values), the device changes the mode of operations for these pins to an output function. In this mode the pins produce the specified buffered clocks to external loads.

To program (load) the internal configuration register for these pins, a resistor is connected to either the VDD (logic 1) power supply or the GND (logic 0) voltage potential. A 10 Kilohm (10K) resistor is used to provide both the solid CMOS programming voltage needed during the power-up programming period and to provide an insignificant load on the output clock during the subsequent operating period.

Figure 1 shows a means of implementing this function when a switch or 2 pin header is used. With no jumper is installed the pin will be pulled high. With the jumper in place the pin will be pulled low. If programmability is not necessary, than only a single resistor is necessary. The programming resistors should be located close to the series termination resistor to minimize the current loop area. It is more important to locate the series termination resistor close to the driver than the programming resistor.

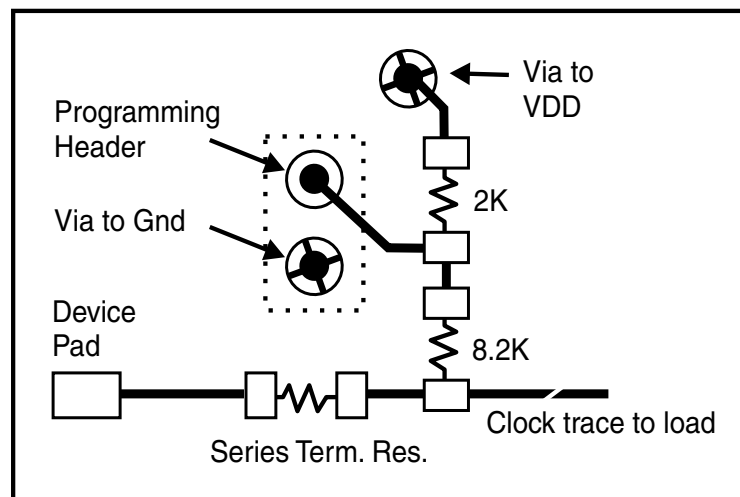
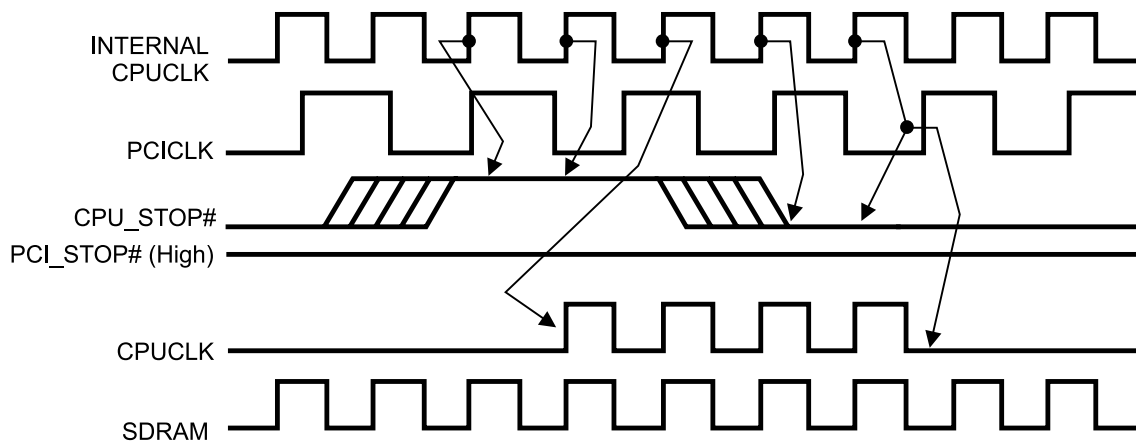

Fig. 1



CPU_STOP# Timing Diagram

CPU_STOP# is an asynchronous input to the clock synthesizer. It is used to turn off the CPU clocks for low power operation. CPU_STOP# is synchronized by the ICS9248-146. The minimum that the CPU clock is enabled (CPU_STOP# high pulse) is 100 CPU clocks. All other clocks will continue to run while the CPU clocks are disabled. The CPU clocks will always be stopped in a low state and start in such a manner that guarantees the high pulse width is a full pulse. CPU clock on latency is less than 4 CPU clocks and CPU clock off latency is less than 4 CPU clocks.



Notes:

1. All timing is referenced to the internal CPU clock.
2. CPU_STOP# is an asynchronous input and metastable conditions may exist. This signal is synchronized to the CPU clocks inside the ICS9248-146.
3. All other clocks continue to run undisturbed. (including SDRAM outputs).



PCI_STOP# Timing Diagram

PCI_STOP# is an asynchronous input to the **ICS9248-146**. It is used to turn off the PCICLK clocks for low power operation. PCI_STOP# is synchronized by the **ICS9248-146** internally. The minimum that the PCICLK clocks are enabled (PCI_STOP# high pulse) is at least 10 PCICLK clocks. PCICLK clocks are stopped in a low state and started with a full high pulse width guaranteed. PCICLK clock on latency cycles are only one rising PCICLK clock off latency is one PCICLK clock.

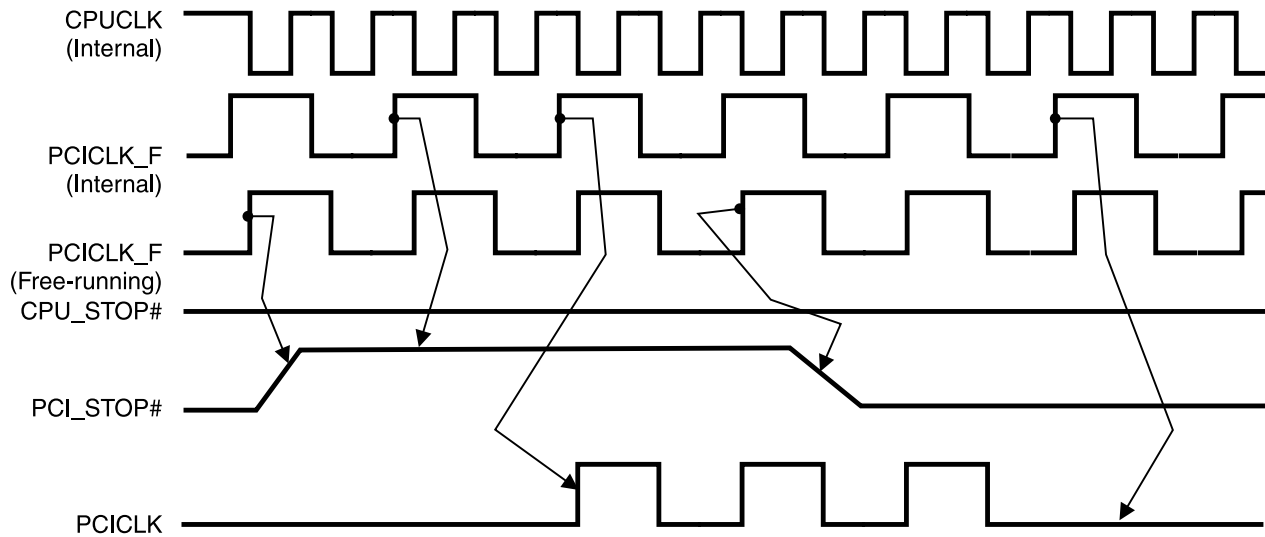

Notes:

1. All timing is referenced to the Internal CPUCLK (defined as inside the ICS9248-146 device.)
2. PCI_STOP# is an asynchronous input, and metastable conditions may exist. This signal is required to be synchronized inside the ICS9248-146.
3. All other clocks continue to run undisturbed.
4. CPU_STOP# is shown in a high (true) state.



SDRAM_STOP# Timing Diagram

SDRAM_STOP# is an asynchronous input to the clock synthesizer. It is used to stop SDRAM clocks for low power operation. SDRAM_STOP# is synchronized to complete its current cycle, by the **ICS9248-146**. All other clocks will continue to run while the SDRAM clocks are disabled. The SDRAM clocks will always be stopped in a low state and start in such a manner that guarantees the high pulse width is a full pulse.

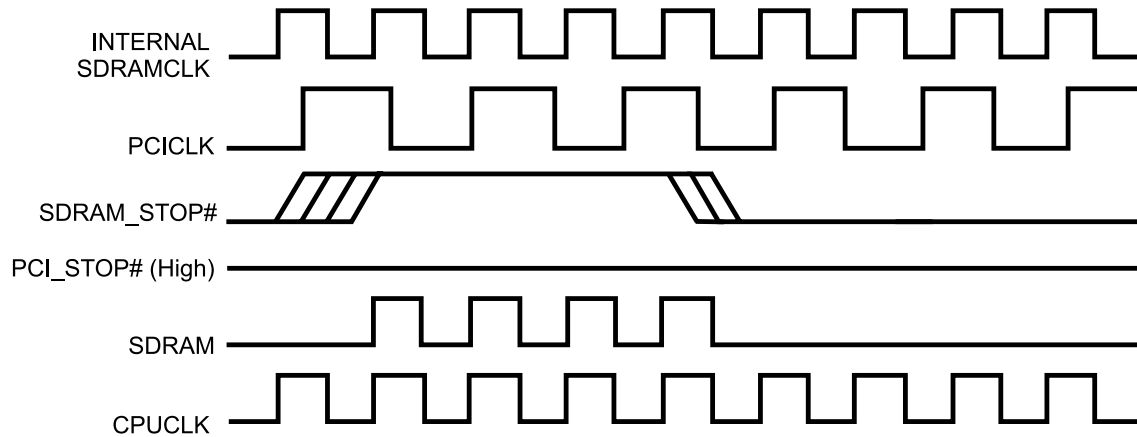

Notes:

1. All timing is referenced to the internal CPU clock.
2. SDRAM is an asynchronous input and metastable conditions may exist. This signal is synchronized to the SDRAM clocks inside the ICS9248-146.
3. All other clocks continue to run undisturbed.



PD# Timing Diagram

The power down selection is used to put the part into a very low power state without turning off the power to the part. PD# is an asynchronous active low input. This signal needs to be synchronized internal to the device prior to powering down the clock synthesizer.

Internal clocks are not running after the device is put in power down. When PD# is active low all clocks need to be driven to a low value and held prior to turning off the VCOs and crystal. The power up latency needs to be less than 3 mS. The power down latency should be as short as possible but conforming to the sequence requirements shown below. PCI_STOP# and CPU_STOP# are considered to be don't cares during the power down operations. The REF and 48MHz clocks are expected to be stopped in the LOW state as soon as possible. Due to the state of the internal logic, stopping and holding the REF clock outputs in the LOW state may require more than one clock cycle to complete.



Notes:

1. All timing is referenced to the Internal CPUCLK (defined as inside the ICS9248-146 device).
2. As shown, the outputs Stop Low on the next falling edge after PD# goes low.
3. PD# is an asynchronous input and metastable conditions may exist. This signal is synchronized inside this part.
4. The shaded sections on the VCO and the Crystal signals indicate an active clock.
5. Diagrams shown with respect to 133MHz. Similar operation when CPU is 100MHz.

ICS9248-146

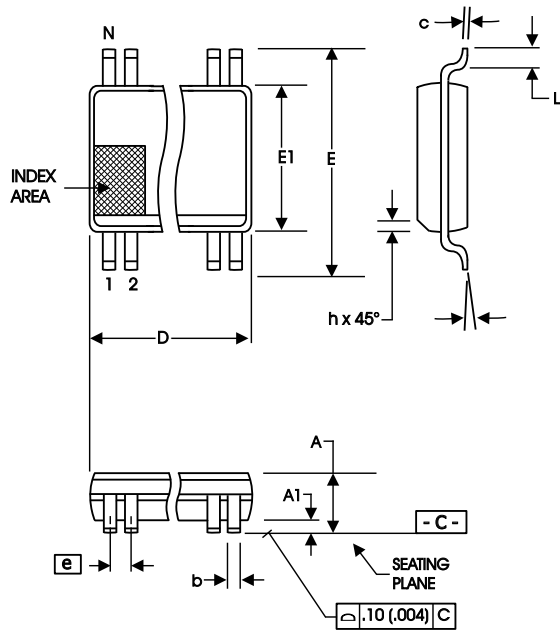

300 mil SSOP Package

SYMBOL	In Millimeters		In Inches	
	COMMON DIMENSIONS	COMMON DIMENSIONS	COMMON DIMENSIONS	COMMON DIMENSIONS
	MIN	MAX	MIN	MAX
A	2.41	2.80	.095	.110
A1	0.20	0.40	.008	.016
b	0.20	0.34	.008	.0135
c	0.13	0.25	.005	.010
D	SEE VARIATIONS		SEE VARIATIONS	
E	10.03	10.68	.395	.420
E1	7.40	7.60	.291	.299
e	0.635 BASIC		0.025 BASIC	
h	0.38	0.64	.015	.025
L	0.50	1.02	.020	.040
N	SEE VARIATIONS		SEE VARIATIONS	
α	0°	8°	0°	8°

VARIATIONS

N	D mm.		D (inch)	
	MIN	MAX	MIN	MAX
48	15.75	16.00	.620	.630

Reference Doc.: JEDEC Publication 95, MO-118

10-0034

Ordering Information

ICS9248yF-146-T

Example:

ICS XXXX y F - PPP - T

