

YAMAHA LSI

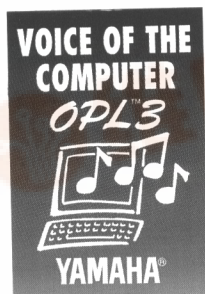

YMF262

OPL™

FM Operator Type L3 (OPL3)

■ OVERVIEW

The YMF262 (OPL3) was developed as a sound source LSI for computer and game equipment. The YMF262 contains an FM sound source which may be controlled by software. In addition, five different rhythm sounds (bass drum, snare drum, tom tom, top cymbal and hi hat cymbal) are available. The YMF262 is register compatible with the YM3812 (OPL2), with twice the number of signal sources, four new operator modes, selectable waveform and 4 channel output.

■ FEATURES

- Registers are compatible with YM3812 (OPL2) FM sound source.
- Up to six sounds can be used as four-operator melody sounds for variety.
- 18 simultaneous melody sounds, or 15 melody sounds with five rhythm sounds (with two operators).
- Six four-operator melody sounds and six two-operator melody sounds, or six four-operator melody sounds, three two-operator melody sounds and five rhythm sounds (with four operators).
- Eight selectable waveforms.
- 4-channel sound output.
- YMF262 compatible DAC (YAC512) is available.
- LFO for vibrato and tremolo effects.
- Two programmable timers.
- Shorter register access time compared with YM3812.
- 5V single supply silicon gate CMOS process.
- 24 Pin SOP Package (YMF262-M), 48 Pin SQFP Package (YMF262-S).

OPL™ is a trade mark of YAMAHA Corporation which represents a full register compatibility with YAMAHA YM3812 (OPL2).

YAMAHA CORPORATION

YMF262 CATALOG
CATALOG No. : 4MF262A6
1994.11

■ BLOCK DIAGRAM

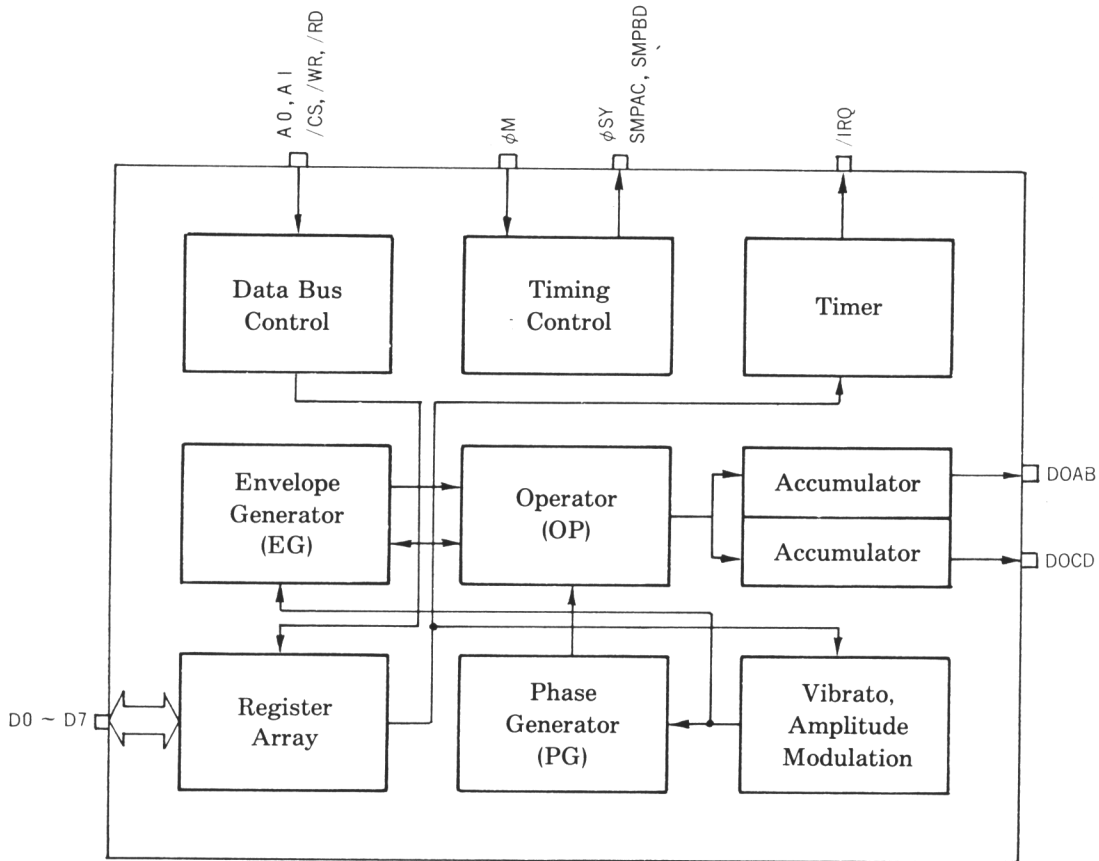

■ PIN OUT DIAGRAM of YMF262-M

● YMF262-M

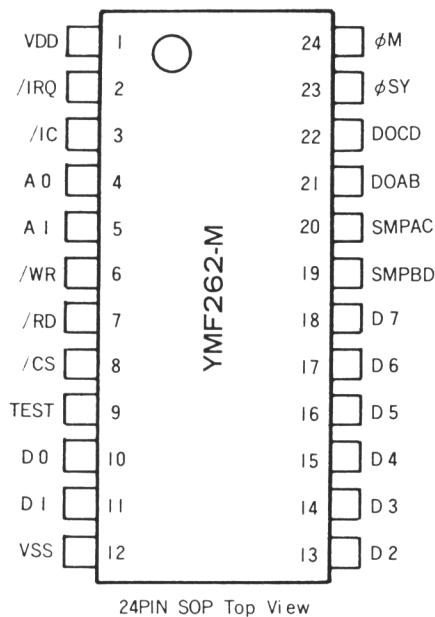

● YMF262-S

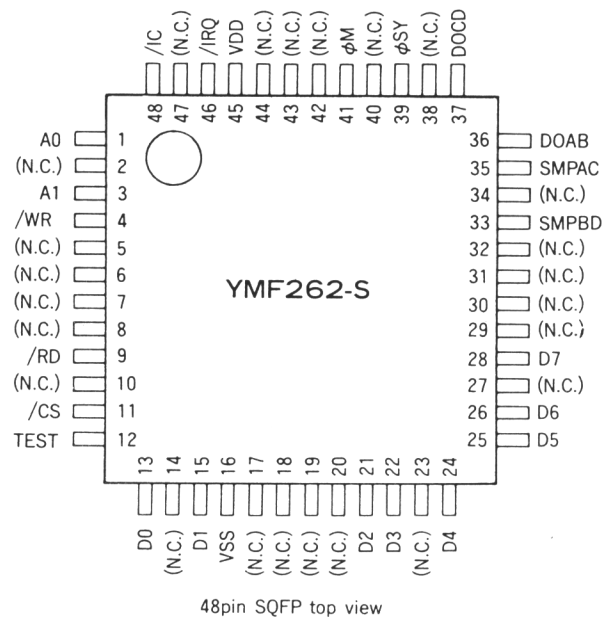

■ PIN CONFIGURATION

No.		I/O	Pin name	Function
24SOP	48SQFP			
1	45	-	V _{DD}	+5V supply
2	46	OD	/IRQ	Timer interrupt request
3	48	I+	/IC	Initial clear
4	1	I	A0	CPU interface Address select input
5	3	I	A1	CPU interface Address select input
6	4	I	/WR	CPU interface Write enable input
7	9	I	/RD	CPU interface Read enable input
8	11	I+	/CS	CPU interface Chip select input
9	12	O	TEST	LSI test pin (normally NC)
10	13	I/O	D0	CPU interface Data bus (LSB)
11	15	I/O	D1	CPU interface Data bus
12	16		V _{SS}	Ground
13	21	I/O	D2	CPU interface Data bus
14	22	I/O	D3	CPU interface Data bus
15	24	I/O	D4	CPU interface Data bus
16	25	I/O	D5	CPU interface Data bus
17	26	I/O	D6	CPU interface Data bus
18	28	I/O	D7	CPU interface Data bus (MSB)
19	33	O	SMPBD	DAC interface B and D channel sample/hold
20	35	O	SMPAC	DAC interface A and C channel sample/hold
21	36	O	DOAB	DAC interface A and B channel serial data output
22	37	O	DOCD	DAC interface C and D channel serial data output
23	39	O	øSY	DAC interface Data latch signal
24	41	I	øM	Master clock input (14.32 MHz)

Note : OD is open drain output pin.

I+ is pull up input pin.

■ FUNCTIONS

1. Master Clock ϕM

All operations in the LSI are controlled by the 14.32 MHz master clock signal applied to the ϕM pin.

2. CPU Interface $/CS, /RD, /WR, A0, A1, D0-D7$

Sound generation is controlled by writing data in these registers. Writing data to a register or reading the status from a register is accomplished through an 8 bit parallel CPU interface signal. D0-D7 are a bidirectional data bus, and $/CS, /RD, /WR, A0,$ and $A1$ are data bus control signals.

The data bus is controlled as follows:

$/CS$	$/RD$	$/WR$	A0	A1	CPU Access Mode
H	X	X	X	X	Inactive mode
L	H	L	L	L/H	Address write mode
L	H	L	H	X	Data write mode
L	L	H	L	L	Status read mode

X: Don't care

Note: Operation in states other than those listed above is not guaranteed.

(a) Inactive mode

When $/CS = 'H'$, the data bus D0-D7 are in a high impedance state.

(b) Address write mode

This mode is used to specify the write address. For register array 0, $A1 = 'L'$. For register array 1, $A1 = 'H'$. The address of the data should be output on the data bus. After this cycle, data may be written in data write mode after a minimum of 32 master clock cycles.

(c) Data write mode

Write data at the address specified previously. The data to be written should be output on the data bus. A wait of at least 32 master clock cycles is required before the next address write or data write.

(d) Status read mode

Read the status of the LSI. The status is output on the data bus.

3. DAC Interface DOAB, DOCD, ϕ SY, SMPAC, SMPBD

YMF262 generates 4 channel sounds, which are output from DOAB and DOCD. Data streams of A and B channel are output from pin DOAB and data streams of C and D channel are output from pin DOCD. These sound data are transmitted as 16-bit offset serial binary data stream. These data streams are designed as input to the YAC512 D/A converter. The YMF262's sampling frequency is 49.7 kHz. As part of the YMF262/YAC512 interface, the YMF262 outputs three timing signals (ϕ SY, SMPBD, SMPAC). Fig 1 shows these timing. In this case, please take care that the assignment of YAC512 audio output channel is changed according to connection of sample/hold signal (See Exsample).

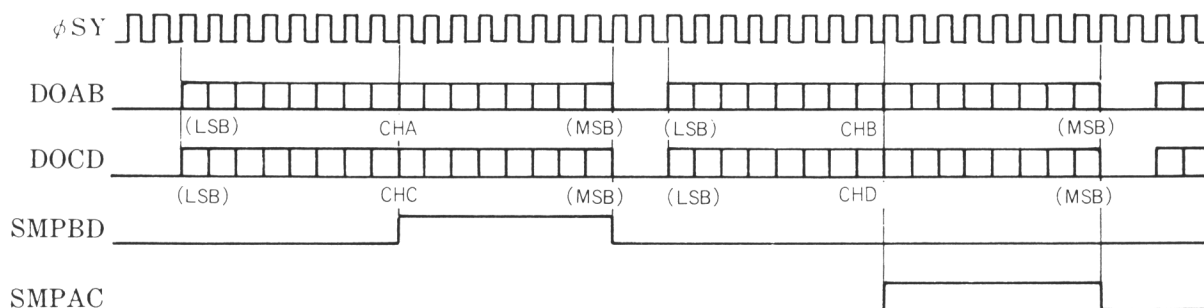

Example 1

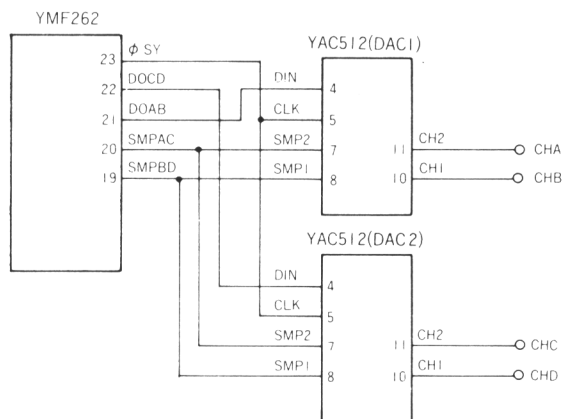

Matrix table of YMF262 register and YAC512 output channel

	DOAB (DAC 1)		DOCD (DAC 2)	
	CH1	CH2	CH1	CH2
CHA		○		
CHB	○			
CHC				○
CHD			○	

Example 2

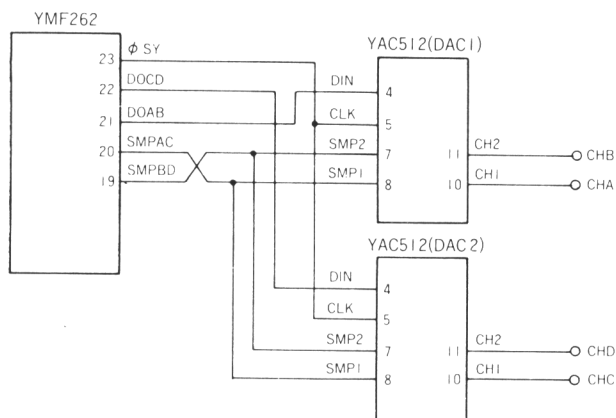

Matrix table of YMF262 register and YAC512 output channel

	DOAB (DAC 1)		DOCD (DAC 2)	
	CH1	CH2	CH1	CH2
CHA	○			
CHB		○		
CHC			○	
CHD				○

■ REGISTER MAP

ADDR (HEX)	REGISTER ARRAY 0 (A1 = 'L')								REGISTER ARRAY 1 (A1 = 'H')															
	D7	D6	D5	D4	D3	D2	D1	D0	D7	D6	D5	D4	D3	D2	D1	D0								
\$ 01	LSI TEST								LSI TEST															
\$ 02	TIMER 1																							
\$ 03	TIMER 2																							
\$ 04	RST	MT1	MT2					ST2	ST1	CONNECTION SEL														
\$ 05									NEW															
\$ 08	NTS																							
\$ 20 : \$ 35	AM	VIB	EGT	KSR					MULT	AM	VIB	EGT	KSR					MULT						
\$ 40 : \$ 55	KSL								TL	KSL								TL						
\$ 60 : \$ 75	AR								DR	AR								DR						
\$ 80 : \$ 95	SL								RR	SL								RR						
\$ A0 : \$ A8	F NUMBER(L)								F NUMBER(L)															
\$ B0 : \$ B8				KON	BLOCK			FNUM(H)				KON	BLOCK			FNUM(H)								
\$ BD	DAM	DVB	RYT	BD	SD	TOM	TC	HH																
\$ C0 : \$ C8	CHD	CHC	CHB	CHA	FB			CNT	CHD	CHC	CHB	CHA	FB			CNT								
\$ E0 : \$ F5									WS												WS			

Note: All registers are cleared at reset.

■ FM SIGNAL SOURCE ORGANIZATION

Channel signal (two-operator)	1	2	3	4	5	6	7 RYT	8 RYT	9 RYT
Channel signal (four-operator)	1	2	3	1	2	3	/	/	/
Slot 1 signal	1	2	3	7	8	9	13	14	15
Slot 2 signal	4	5	6	10	11	12	16	17	18
Register settings for the slot (A1='L')	20 23 40 43 60 63 80 83 E0 E3	21 24 41 44 61 64 81 84 E1 E4	22 25 42 45 62 65 82 85 E2 E5	28 2B 48 4B 68 6B 88 8B E8 EB	29 2C 49 4C 69 6C 89 8C E9 EC	2A 2D 4A 4D 6A 6D 8A 8D EA ED	30 33 50 53 70 73 90 93 F0 F3	31 34 51 54 71 74 91 94 F1 F4	32 35 52 55 72 75 92 95 F2 F5
Register settings for channel (two-operator, A1='L')	A0 B0 C0	A1 B1 C1	A2 B2 C2	A3 B3 C3	A4 B4 C4	A5 B5 C5	A6 B6 C6	A7 B7 C7	A8 B8 C8
Register settings for channel (four-operator, A1='L')	A0 B0 C0	A1 B1 C1	A2 B2 C2	C3	C4	C5	/		

Channel signal (two-operator)	10	11	12	13	14	15	16	17	18
Channel signal (four-operator)	4	5	6	4	5	6	/	/	/
Slot 1 signal	19	20	21	25	26	27	31	32	33
Slot 2 signal	22	23	24	28	29	30	34	35	36
Register settings for the slot (A1='H')	20 23 40 43 60 63 80 83 E0 E3	21 24 41 44 61 64 81 84 E1 E4	22 25 42 45 62 65 82 85 E2 E5	28 2B 48 4B 68 6B 88 8B E8 EB	29 2C 49 4C 69 6C 89 8C E9 EC	2A 2D 4A 4D 6A 6D 8A 8D EA ED	30 33 50 53 70 73 90 93 F0 F3	31 34 51 54 71 74 91 94 F1 F4	32 35 52 55 72 75 92 95 F2 F5
Register settings for channel (two-operator, A1='H')	A0 B0 C0	A1 B1 C1	A2 B2 C2	A3 B3 C3	A4 B4 C4	A5 B5 C5	A6 B6 C6	A7 B7 C7	A8 B8 C8
Register settings for channel (four-operator, A1='H')	A0 B0 C0	A1 B1 C1	A2 B2 C2	C3	C4	C5	/		

■ REGISTERS

(1) Description

TIMER 1: Timer 1 preset value

Timer 1 is an 8 bit preset counter. This counter is every $80\mu\text{S}$, and /IRQ is generated when the counter overflows. TIMER 1 is the preset value. When overflow occurs, this value is automatically re-loaded into the counter. The time until /IRQ is generated (tov) is calculated as follows:

$$\begin{aligned} \text{tov}[\text{ms}] &= (255 - N1) * 0.08 \\ N1 &= D7 * 2^7 + D6 * 2^6 + D5 * 2^5 + D4 * 2^4 + D3 * 2^3 + D2 * 2^2 + D1 * 2 + D0 \end{aligned}$$

TIMER 2: Timer 2 preset value

Timer 2 is an 8 bit preset counter. This counter is every $320\mu\text{S}$, and /IRQ is generated when the counter overflows. TIMER 2 is the preset value. When overflow occurs, this value is automatically re-loaded into the counter. The time until /IRQ is generated (tov) is calculated as follows:

$$\begin{aligned} \text{tov}[\text{ms}] &= (255 - N1) * 0.32 \\ N1 &= D7 * 2^7 + D6 * 2^6 + D5 * 2^5 + D4 * 2^4 + D3 * 2^3 + D2 * 2^2 + D1 * 2 + D0 \end{aligned}$$

RST (IRQ RESET): /IRQ reset

Reset the /IRQ signal generated by timers 1 and 2. RST='1' sets /IRQ='H'.

MT1 (MASK TIMER1): Timer 1 mask

If MT1='1', /IRQ is not generated when timer 1 overflows.

MT2 (MASK TIMER2): Timer 2 mask

If MT2='1', /IRQ is not generated when timer 2 overflows.

ST1 (START TIMER1): Timer 1 control

When ST1='1', timer 1 loads the preset value and starts counting. If ST1='0', timer 1 is stopped.

ST2 (START TIMER2): Timer 2 control

When ST2='1', timer 2 loads the preset value and starts counting. If ST2='0', timer 2 is stopped.

NTS (NOTE SEL): Keyboard split selection

Selects the keyboard split method to determine the key scale number.

When NTS=0

BLOCK Data	0		1		2		3		4		5		6		7	
F-NUMBER MSB	*		*		*		*		*		*		*		*	
F-NUMBER 2nd	0	1	0	1	0	1	0	1	0	1	0	1	0	1	0	1
Key scale No.	0	1	2	3	4	5	6	7	8	9	10	11	12	13	14	15

When NTS=1

BLOCK Data	0		1		2		3		4		5		6		7	
F-NUMBER MSB	0	1	0	1	0	1	0	1	0	1	0	1	0	1	0	1
F-NUMBER 2nd	*	*	*	*	*	*	*	*	*	*	*	*	*	*	*	*
Key scale No.	0	1	2	3	4	5	6	7	8	9	10	11	12	13	14	15

*: Don't care

AM (AMPLITUDE MODULATION): Tremolo on/off

Turns tremolo on for the corresponding slot when AM='1'. The repetition rate is 3.7 Hz, and the depth is controlled by DAM.

VIB (VIBRATO): Vibrato on/off

Turns vibrato on for the corresponding slot when VIB='1'. The repetition rate is 6.1 Hz and the depth is controlled by DVB.

EGT (ENVELOPE TYPE): Select sustain/decay

EGT='1' selects sustained sound, and maintains the SUSTAIN LEVEL while KON is 1. EGT='0' selects decay, and the RELEASE RATE takes effect even if KON is maintained at 1.

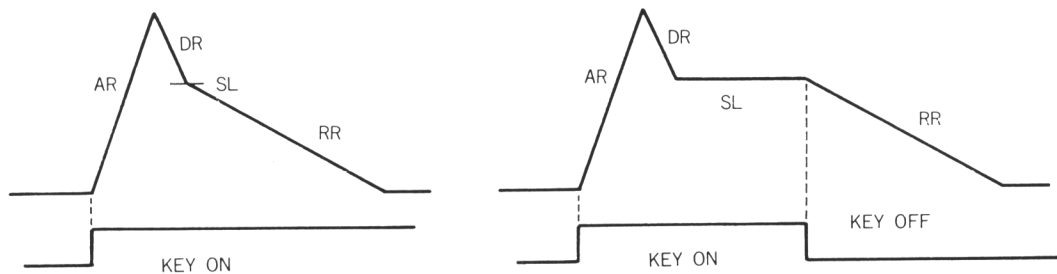

KSR (KEY SCALE RATE): Select key scale RATE

With normal musical instruments, the attack/decay rate becomes faster as the pitch increases. The key scale RATE controls simulation of this effect. An offset is added to the individual ATTACK, DECAY and RELEASE rates as follows:

$$\text{Actual rate} = \text{Rate value} * 4 + \text{Rof}$$

If rate value=0, actual rate =0.

Rof is set as follows depending on the KSR setting:

Key scale No.	0	1	2	3	4	5	6	7	8	9	10	11	12	13	14	15	
Rof	KSR=0	0	0	0	0	1	1	1	1	2	2	2	2	3	3	3	3
	KSR=1	0	1	2	3	4	5	6	7	8	9	10	11	12	13	14	15

MULT (MULTIPLE): Frequency data multiplier

Sets the multiplier for the frequency data specified by BLOCK and F-NUMBER. This multiplier is applied to the FM carrier and modulation frequencies.

MULT	0	1	2	3	4	5	6	7	8	9	A	B	C	D	E	F
Multiplier	1/2	1	2	3	4	5	6	7	8	9	10	10	12	12	15	15

KSL (KEY SCALE LEVEL): Key scale level selection

With musical instruments, volume decreases as pitch increases. LEVEL key scale values are used to simulate this effect:

KSL	0	2	1	3
Attenuation	0	1.5dB/oct	3dB/oct	6dB/oct

TL (TOTAL LEVEL): Modulation, volume setting

Attenuation is performed according to the envelope generator output. The modulation or volume is controlled.

$$\text{Attenuation} = 24 * D5 + 12 * D4 + 6 * D3 + 3 * D2 + 1.5 * D1 + 0.75 * D0 \text{ (dB)}$$

AR (ATTACK RATE): Attack rate setting

$$\text{Attack rate} = 2^3 * D7 + 2^2 * D6 + 2 * D5 + D4$$

DR (DECAY RATE): Decay rate setting

$$\text{Decay rate} = 2^3 * D3 + 2^2 * D2 + 2 * D1 + D0$$

SL (SUSTAIN LEVEL): Sustained level setting

$$\text{Sustain level} = 24 \cdot D7 + 12 \cdot D6 + 6 \cdot D5 + 3 \cdot D4$$

When $D7 = D6 = D5 = D4 = 1$, level = 93dB

RR (RELEASE RATE): Release rate setting

$$\text{Release rate} = 2^3 \cdot D3 + 2^2 \cdot D2 + 2 \cdot D1 + D0$$

FNUM (F-NUMBER): Scale data within the octave

Gives pitch data along with BLOCK data.

$$\text{F-NUMBER} = f \cdot 2^{19} / f_s / 2^{\text{BLOCK}-1}$$

(f: frequency; f_s : sampling frequency; $f_s = fM/288$)

KON (KEY-ON): /Sound generation ON/OFF

If KON = '1', the channel generates sound.

BLOCK: Octave data

Generates octave data with F-NUMBER data.

DAM (AMPLITUDE MODULATION DEPTH): Select amplitude modulation depth

When DAM = '1', 4.8dB. When DAM = '0', 1dB.

DVB (VIBRATO DEPTH): Select vibrato depth

When DVB = '1', 14 percent. When DVB = '0', 7 percent.

RYT (RHYTHM MODE): Select rhythm sound mode

Channels 7-9 are used for rhythm sounds when RYT = '1'.

BD (BASS DRUM), SD (SNARE DRUM), TOM (TOM TOM), TC (TOP CYMBAL), HH (HI-HAT): ON/OFF

Sound output on/off switch for each sound. When any of these is set to 1, the corresponding sound is generated.

Rhythm Sound	Slot Used
BASS DRUM	13, 16
SNARE DRUM	17
TOM TOM	15
TOP - CYMBAL	18
HI - HAT	14

FB (FEED BACK): Modulation depth for slot 1 FM feed back

FB	0	1	2	3	4	5	6	7
Modulation	0	$\pi/16$	$\pi/8$	$\pi/4$	$\pi/2$	π	2π	4π

NEW: OPL3/OPL2 Operation selection

If NEW='1', OPL3 operation is selected and data is written when A1='H'. To use OPL3 functions, write NEW='1' during initialization.

CNT (CONNECTION): Operator connection

Two-operator mode uses the following connection:

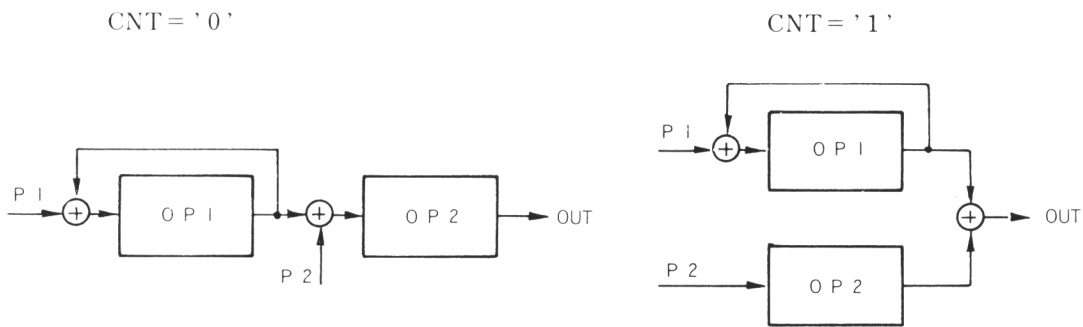

In four-operator mode, both CNT bits are used to specify the connection:

Channel No. (four-operator)	1	2	3	4	5	6
CNT Address	C0, C3	C1, C4	C2, C5	C0, C3	C1, C4	C2, C5
A1	'L'			'H'		

The connection is as follows:

$CNT(C_n) = '0'$, $CNT(C_{n+3}) = '0'$

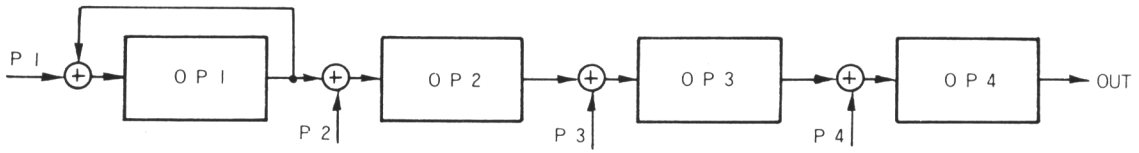

$CNT(C_n) = '0'$, $CNT(C_{n+3}) = '1'$

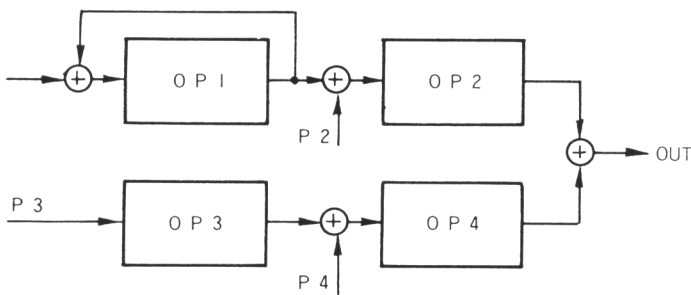

$CNT(C_n) = '1'$, $CNT(C_{n+3}) = '0'$

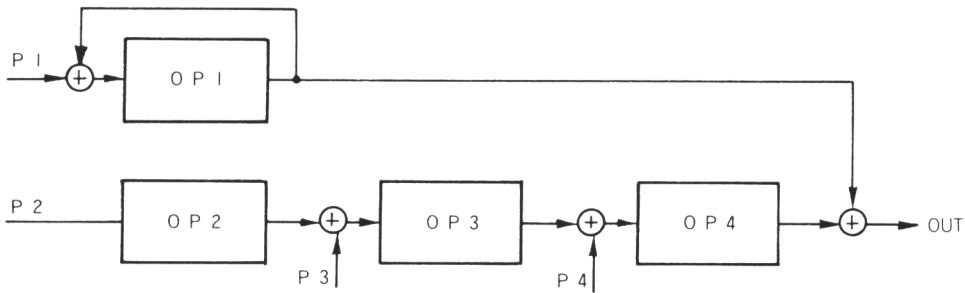



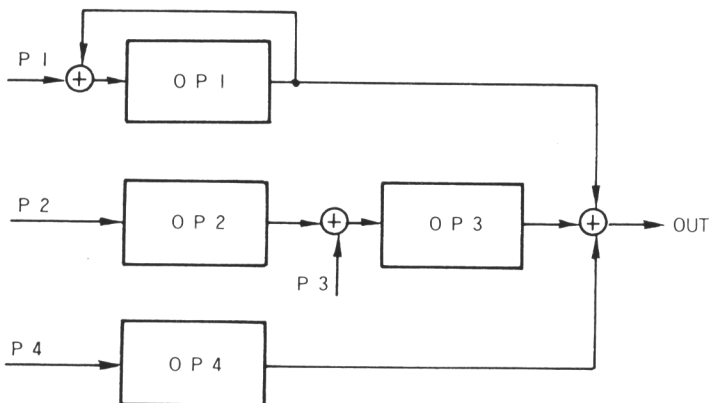





$CNT(C_n) = '1'$, $CNT(C_{n+3}) = '1'$

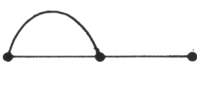

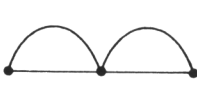
WS (WAVE SELECT): Select waveform

Select the waveform used for carrier and modulation.

WS=0		WS=4	
WS=1		WS=5	
WS=2		WS=6	
WS=3		WS=7	

CHA (CHANNEL A), CHB (CHANNEL B), CHC (CHANNEL C), CHD (CHANNEL D): Select output

When any of these bits is set to 1, data is output to the corresponding channel. CHA and CHB are output from the DOAB pin, and CHC and CHD are output from the DOCD pin.

CONNECTION SEL: Four-operator mode

CONNECTION SEL	D5	D4	D3	D2	D1	D0
Four-operator channel	6	5	4	3	2	1
Two-operator channels used	12, 15	11, 14	10, 13	3, 6	2, 5	1, 4

(2) Status

Bit	D7	D6	D5	D4	D3	D2	D1	D0
Status	IRQ	FT1	FT2					

FT1 (FLAG TIMER1): Timer 1 overflow flag

This flag is set to 1 when timer 1 overflow occurs.

This flag is not reset unless RST is written.

FT2 (FLAG TIMER2): Timer 2 overflow flag

This flag is set to 1 when timer 2 overflow occurs.

This flag is not reset unless RST is written.

IRQ (INTERRUPT REQUEST): Interrupt request

Set to 1 if FT1 or FT2 is set. This flag is not reset unless RST is written.

■ YMF262 ELECTRICAL CHARACTERISTICS

1. Absolute Maximum Ratings

Item	Symbol	Rating	Unit
Power supply voltage	V _{DD}	-0.3 ~ 7.0	V
Input voltage	V _I	-0.3 ~ V _{DD} +0.5	V
Operating temperature	T _{op}	0 ~ 70	°C
Storage temperature	T _{stg}	-50 ~ 125	°C

2. Recommended Operating Conditions

Item	Symbol	Minimum	Typical	Maximum	Unit
Power supply voltage	V _{DD}	4.75	5.00	5.25	V
Operating temperature	T _{op}	0	25	70	°C

3. DC Characteristics (Conditions; T_a=0 ~ 70°C, V_{DD}=5.0 ± 0.25 V)

Item	Symbol	Conditions	Min.	Typ.	Max.	Unit
Power consumption	P _D	V _{DD} =5.0V f _M =14.32MHz			50	mW
Input highlevel voltage 1	V _{IH1}	*1	2.2			V
Input lowlevel voltage 2	V _{IL1}	*1			0.8	V
Input highlevel voltage 2	V _{IH2}	*2	3.5			V
Input lowlevel voltage 2	V _{IL2}	*2			1.0	V
Input leakage current	I _{LI}	V _I =0 ~ 5V, *3	-10		10	μA
Input capacity	C _I				10	pF
Output highlevel voltage	V _{OH}	I _{OH} =-80μA	V _{DD} - 1.0			V
Output lowlevel voltage	V _{OL}	I _{OL} =2.0mA			0.4	V
Output capacity	C _O				10	pF
Output leakage current	I _{LO}	V _I =0 ~ 5V, *4	-10		10	μA
Pull up resistance	R _U		80		400	kΩ

Note) *1: Applied to /WR, /RD, /CS, A0, A1, D0 ~ D7 (when used as input pins)

*2: Applied to φM, /IC

*3: Applied to φM, /WR, /RD, A0, A1, D0 ~ D7 (When used as input pins)

*4: When D0 ~ D7 are in high impedance

4. AC Characteristics (Conditions; $T_a=0 \sim 70^\circ\text{C}$, $V_{DD}=5.0 \pm 0.25 \text{ V}$)

Item	Symbol	Figure	Min.	Typ.	Max.	Unit
Master clock frequency	f_M	Fig A-1	10	14.32	16	MHz
Master clock duty	D		40	50	60	%
Reset pulse width	t_{ICW}	Fig A-2	400/f _M			s
Address setup time	t_{AS}	Fig A-3, 4	10			ns
Address hold time	t_{AH}	Fig A-3, 4	10			ns
Chip select write width	t_{CSW}	Fig A-3	100			ns
Chip select read width	t_{CSR}	Fig A-4	150			ns
Write pulse width	t_{WW}	Fig A-3	100			ns
Write data setup time	t_{WDS}	Fig A-3	10			ns
Write data hold time	t_{WDH}	Fig A-3	20			ns
Read pulse width	t_{RW}	Fig A-4	150			ns
Read data access time	t_{ACC}	Fig A-4			150	ns
Read data hold time	t_{RDH}	Fig A-4	10			ns

*1: Master clock cycle

5. Timing Diagram

(1) Input clock timing

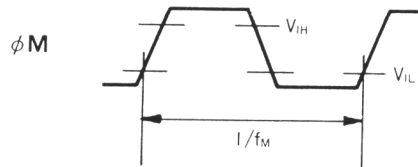

Fig A-1

(2) Reset pulse

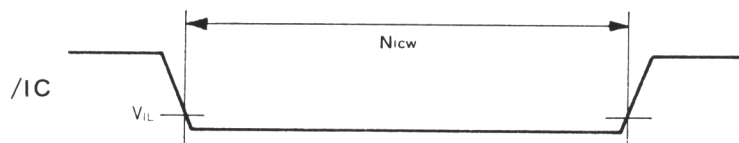

Fig A-2

(3) Address/Data write timing

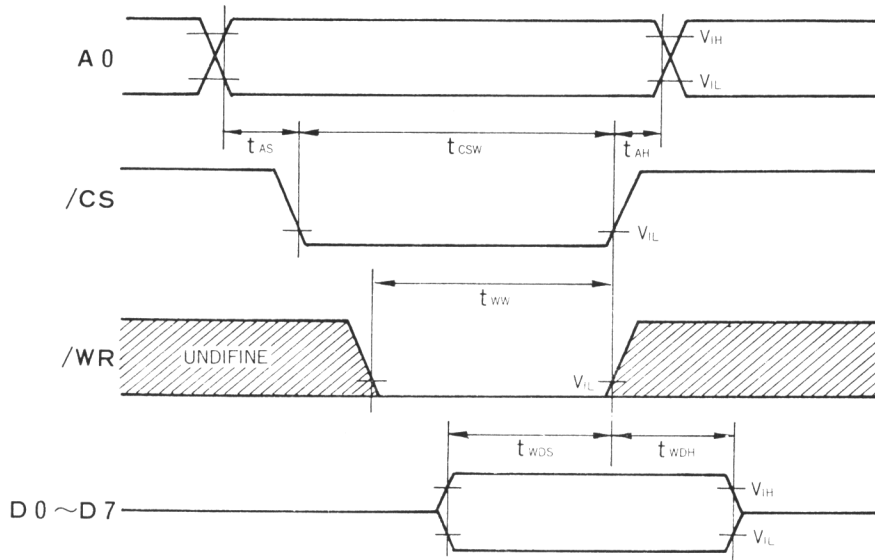

Fig A-3

Note: t_{CSW} , t_{WW} , and t_{WDH} are based on either \overline{CS} or \overline{WR} being driven to high level.

(4) Status read timing

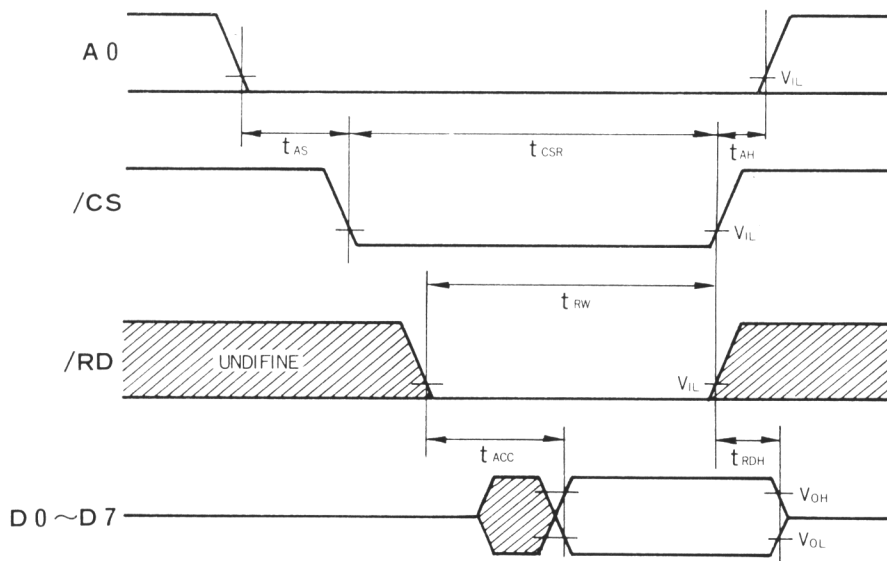

Fig A-4

Note: t_{ACC} is based on whichever of \overline{CS} or \overline{RD} goes to the low level last.

t_{CSW} , t_{WW} , and t_{WDH} are based on either \overline{CS} or \overline{WR} being driven to high level.

■ DIMENSIONS

● YMF262-M

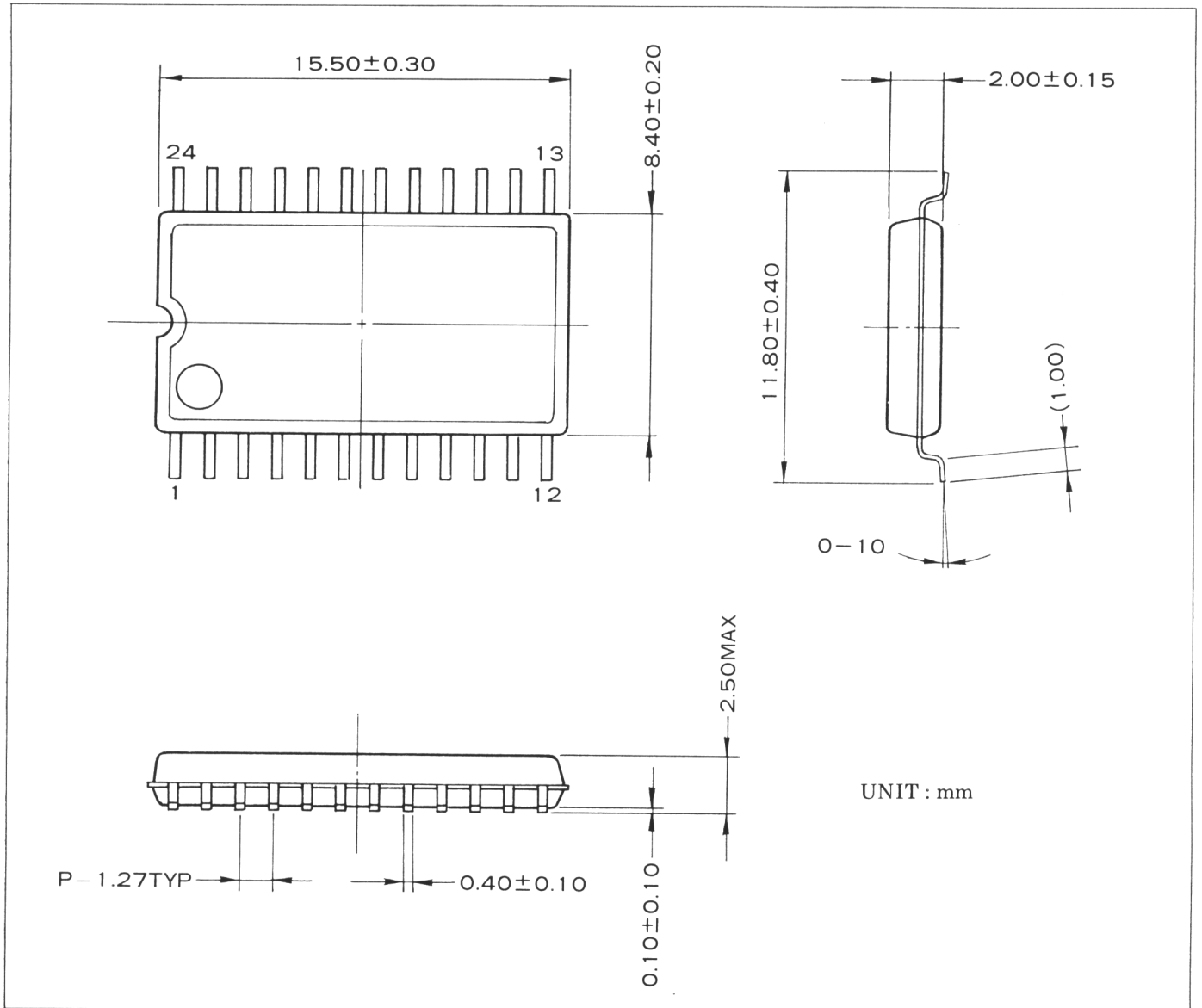

• YMF262-S

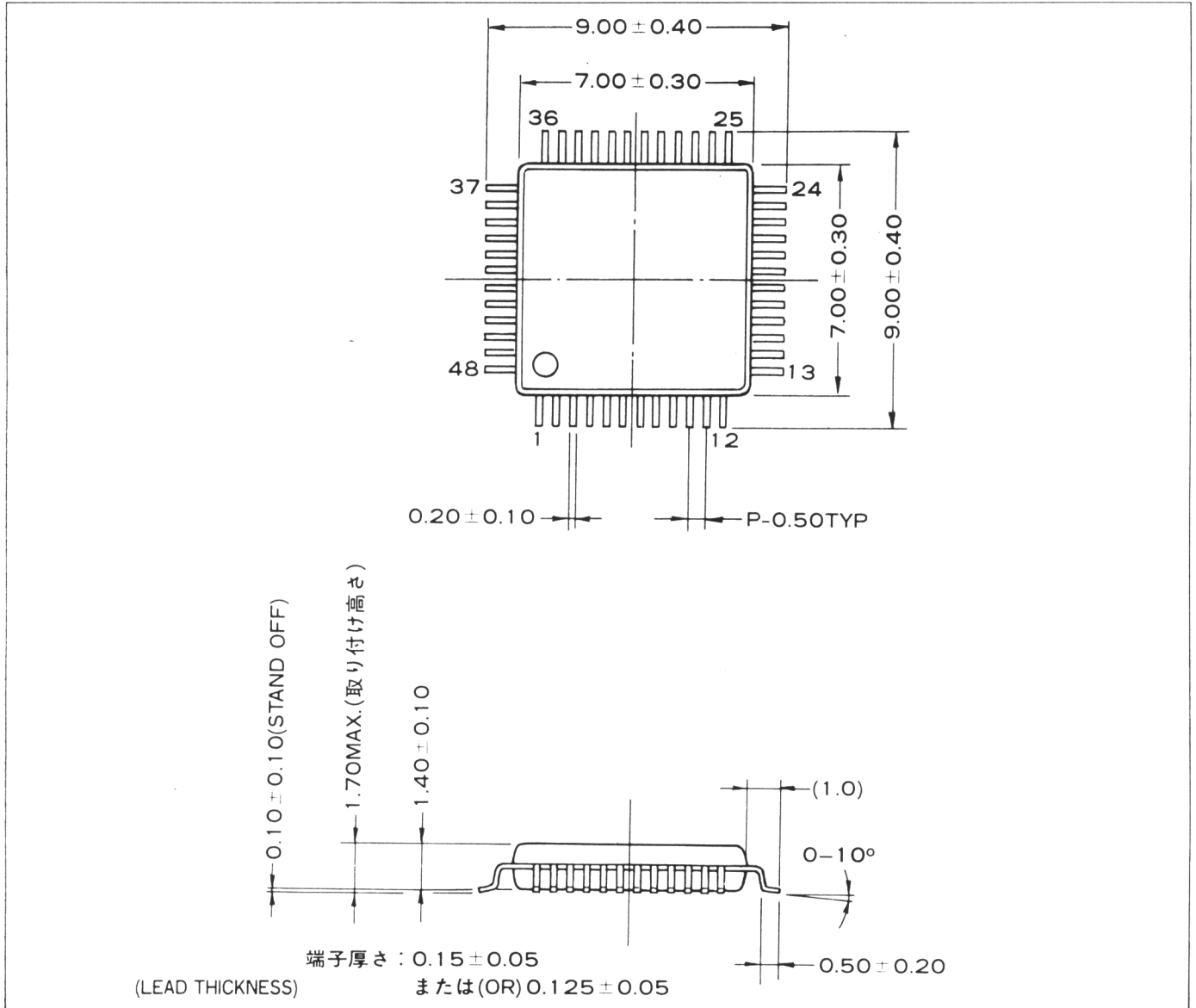

The specifications of this product are subject to improvement changes without prior notice.

_____ AGENCY _____

YAMAHA CORPORATION

Address inquiries to:

Semi-conductor Sales Department

- Head Office 203, Matsunokijima, Toyooka-mura,
Iwata-gun, Shizuoka-ken, 438-01
Electronic Equipment business section
Tel. 0539-62-4918 Fax. 0539-62-5054
- Tokyo Office 2-17-11, Takanawa, Minato-ku,
Tokyo, 108
Tel. 03-5488-5431 Fax. 03-5488-5088
- Osaka Office 3-12-9, Minami Senba, Chuo-ku,
Osaka City, Osaka, 542
Shinsaibashi Plaza Bldg. 4F
Tel. 06-252-7980 Fax. 06-252-5615
- U.S.A. Office YAMAHA Systems Technology.
100 Century Center Court, San Jose, CA95112
Tel. 408-467-2300 Fax. 408-437-8791