



ZA2030 AAM™ 30W Class-D Bridged Audio Amplifier

General Description

The ZA2030 is a fully integrated 30W bridged Class-D Audio Amplifier. This simple, low-cost amplifier exhibits the high fidelity of a Class-A/B amplifier at very high efficiencies. The circuit is based on the proprietary variable frequency topology Analog Adaptive Modulation (AAM, Patent pending) that delivers excellent PSRR, fast response time and operates over a wide supply voltage range.

Features

- 90% Efficiency at 20W
- Frequency to 600kHz
- 30W output at 22Vin
- 2.4V to 22V operation
- Integrated 0.22 Ω switches
- Thermal shutdown
- Cycle-by-cycle short circuit protection
- Amplifies full audio range with low THD+N
- High open loop gain
- Employs soft clipping
- Standby-mode (Mute)

Ordering Information

Part Number* Package
Temperature

ZA2030EWR	20-LD Wide SOIC	-20°C to +85°C
------------------	------------------------	-----------------------

* For Tape & Reel, use suffix -Z (ZA2030EWR-Z)

Applications

- DVD and VCD players
- Audio amplifier
- Home stereo
- Multimedia computer
- Television
- Game machines

Typical Application Circuit

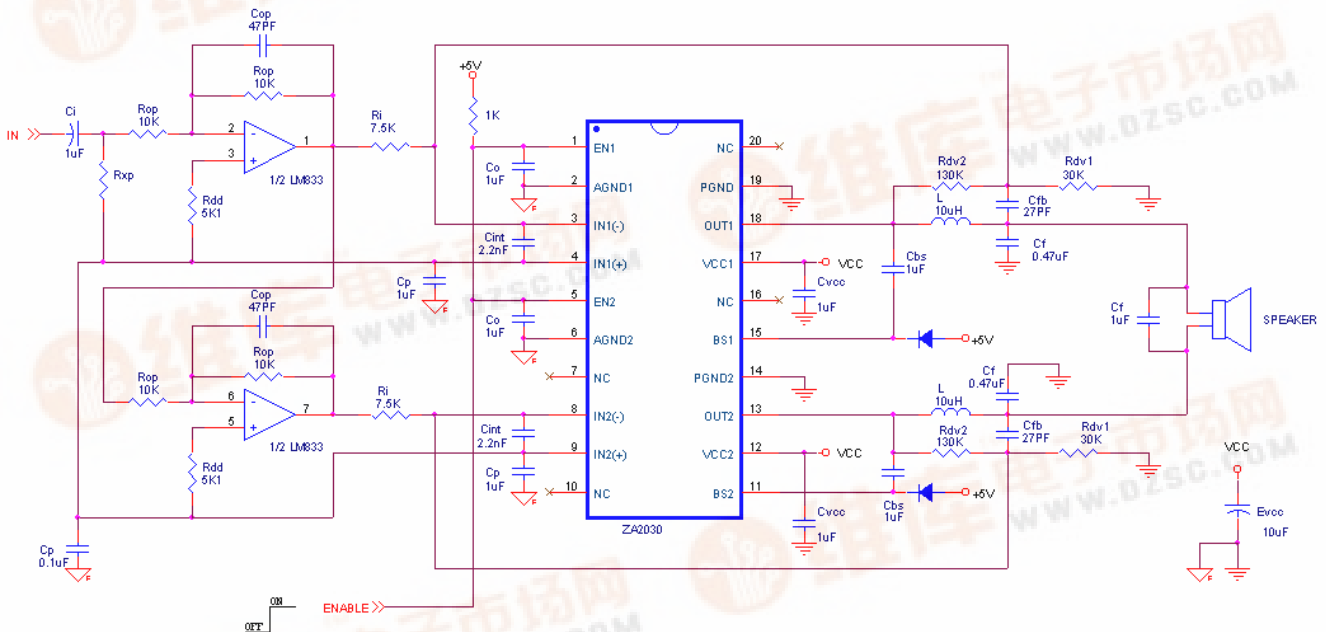

Absolute Maximum Ratings

V _{cc}	25 V
Logic Inputs	-0.3V to 6.5V
Junction Temperature °C	150
Power Dissipation (DIP)	TBD W
Boost Pin Voltage	V _{sw} + 6V
Thermal resistance (DIP)	TBD °C /W
Storage Temperature +150 °C	-55 °C to

Recommended Operating Conditions

Input Voltage V _{cc}	6V to 22V
Operating Frequency	20kHz to 550kHz
Feedback Input	0 to 6V
Operating Temperature	-20 °C to + 85 °C

Electrical Specifications (Unless otherwise specified V_{cc}=22V, T_a=25 °C)

Parameters	Symbol	Condition	Min	Typ	Max	Units
------------	--------	-----------	-----	-----	-----	-------

Controlled Voltage Output

Output voltage swing L	V _L	RL=4 Ω F=1kHz THD=10%	2			V
Output voltage swing H	V _H	RL=4 Ω F=1kHz THD=10%			20	V
PSRR	PSRR	V _{in} =22-21V		1		mV/V
THD+N L	THDL	RL=4 Ω P _{out} =100mW		0.1		%
THD+N M	THDM	RL=4 Ω P _{out} =10W		0.2		%
THD+N H	THDH	RL=4 Ω P _{out} =30W		1.0		%
Closed loop gain	A _{VOL}	See Typical Application		32		dB
Efficiency	η	RL=4 Ω F=1kHz P _{out} =20W		90		%

Voltage Supply

Standby current	I _{cc(off)}	V _{cc} = 18V, V _{EN} = 0V			20	uA
Supply current (operating)	I _{cc(on)}	Typical Application, V _{in} = 0V		10		mA

Output Drivers

On resistance	R _{on}			0.22		Ω
Short circuit current	I _{sc}	Cycle by cycle current limit. Ton < 200ns		4		A
Operating clock frequency	F _{op}				600	kHz

Control Input

Input Range	Pin, lin		0		6	V
Input Leakage	I _L				5	uA
Enable	EN	Enable threshold	4.75			V
Enable current	I _{EN}	Enable = 5V		10		mA

Thermal shutdown	T _{SD}			150		°C
-------------------------	-----------------	--	--	-----	--	----

Note 1. Exceeding these ratings may damage the device.

Note 2. The device is not guaranteed to function outside its operating rating.

Note 3. Measured on approximately 1" square of 1 oz. copper surrounding device leads.

Pin Description

Pin No.	Pin Name	Pin Function
1,5,6,7,15,16	PGnd	Power GND.
2	Out	Output (Pulse Out). Output connected to inductor.
3	Vcc	Power Supply (5.5V-22V)
4	BS	Bootstrap pin for Output FET. 1nF to Out
8	Out	Output (Pulse Out). Output connected to inductor.
9	Vcc	Power Supply (5.5V-22V)
10	BS	Bootstrap pin for Output FET. 1nF to Out
11	AGND	ANALOG GND
12	Nin	Input to the amplifier
13	Pin	Common-mode reference voltage for the amplifier input
14,20	ENABLE	LDO Output and Compensation
17	AGND	ANALOG GND
18	Nin	Input to the amplifier
19	Pin	Common-mode reference voltage for the amplifier input

Reference Design for a 30W Bridged Class-D Amplifier

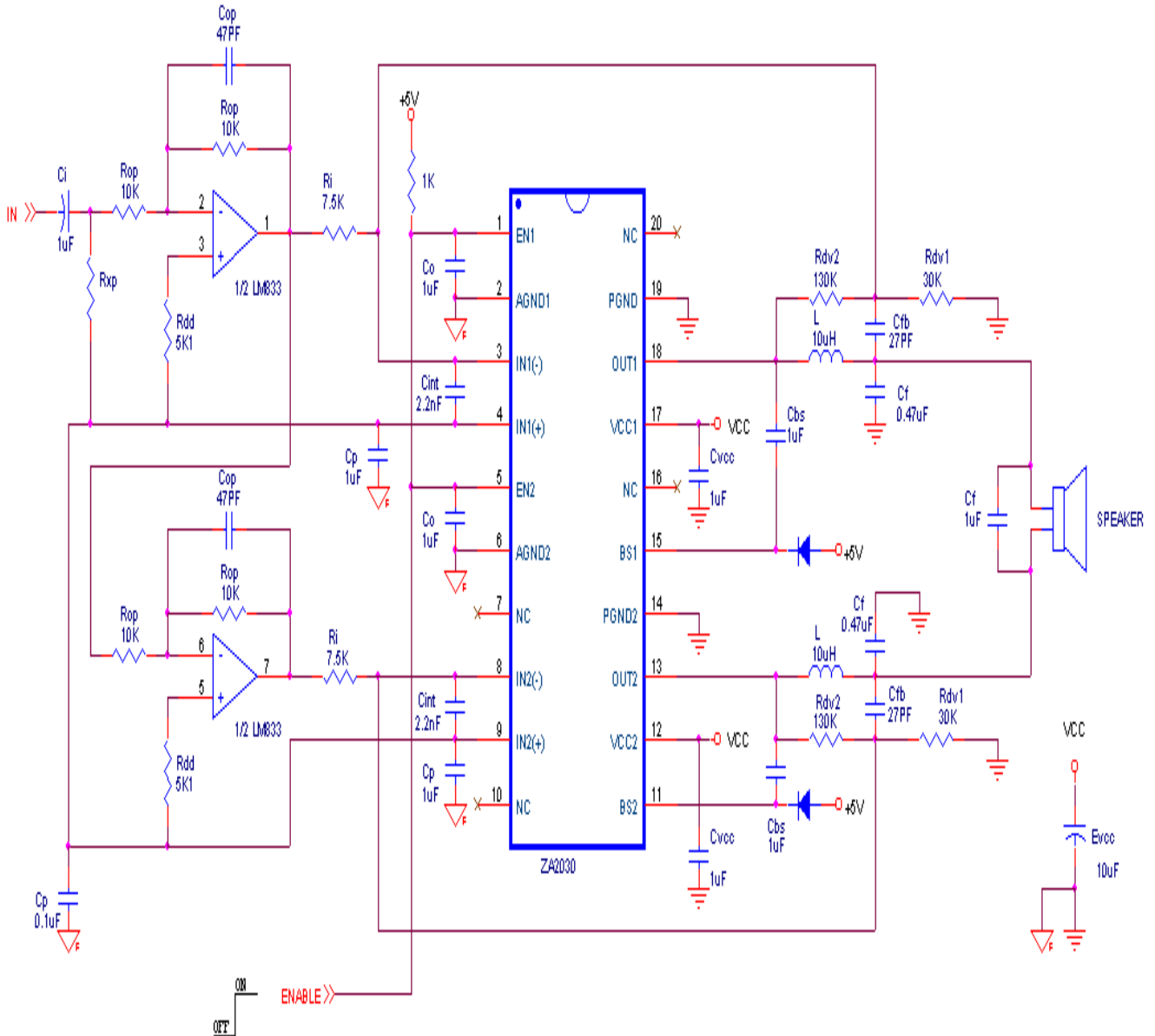

Table 1: Bill of Materials

Item	Qty	Description	Vendor / Part #	Designation
Resistors				
1	6	10KΩ, ±5% 1/4W, leaded	Any	Rop
2	1	1KΩ, ±5% 1/4W, leaded	Any	Rxp
3	2	135Ω, ±5% 1/4W, leaded	Any	RA1, RA2
4	2	30KΩ, ±5% 1/4W, leaded	Any	RB1, RB2
Capacitors				
5	5	1μF, 16V, electrolytic, leaded	Any	Ce,, Ci1, CP
6	1	1μF, 50V, ceramic, leaded	Any	CF
7	2	0.22μF, 16V, ceramic, leaded	Any	CBS
8	2	2.2nF, 16V, ceramic, leaded	Any	Cint
9	1	10μF, 50V, electrolytic, leaded	Any	CVcc1
10	4	1μF, 50V, ceramic, leaded	Any	CVcc, CF,
11	2	100pF, 50V, ceramic, leaded	Any	CA1, CA2
Semiconductors				
12	1	1N5231, zener diode, □ 5%	Any	D1 (C2)
Integrated Circuits				
13	1	ZA2030 20 pin DIP	Vimicro corporation	Vimicro
	1	LM833 Audio Dual Op-Amp	National Semiconductor	NSC
Magnetics				
14	2	39uH, 3A inductor, leaded	Any	L
Hardware				
15	1	Socket, 20-pin DIP	Any	N/A
16	1	PCB, single-sided, ZA2030EVAL, Rev A	Any	N/A