

International IR Rectifier

IRG4ZC70UD

INSULATED GATE BIPOLAR TRANSISTOR WITH
ULTRAFAST SOFT RECOVERY DIODE

Surface Mountable
UltraFast CoPack IGBT

Features

- UltraFast IGBT optimized for high switching frequencies
- IGBT co-packaged with HEXFRED™ ultrafast, ultra-soft recovery antiparallel diodes for use in bridge configurations
- Low gate charge
- Low profile low inductance SMD-10 package
- Separated control & Power-connections for easy paralleling
- Inherently coplanar pins and tab
- Easy solder inspection and cleaning

Benefits

- Highest power density and efficiency available
- HEXFRED diodes optimized for performance with IGBTs; Minimized recovery characteristics
- IGBTs optimized for specific application conditions; high input impedance requires low gate drive power
- Low noise and interference

Absolute Maximum Ratings

	Parameter	Max.	Units
V_{CES}	Collector-to-Emitter Breakdown Voltage	600	V
$I_C @ T_C = 25^\circ\text{C}$	Continuous Collector Current	100	A
$I_C @ T_C = 100^\circ\text{C}$	Continuous Collector Current	50	
I_{CM}	Pulsed Collector Current ①	400	
I_{LM}	Clamped Inductive Load Current ②	400	
$I_F @ T_C = 100^\circ\text{C}$	Diode Continuous Forward Current	50	
I_{FM}	Diode Maximum Forward Current	400	
V_{GE}	Gate-to-Emitter Voltage	± 20	V
$P_D @ T_C = 25^\circ\text{C}$	Maximum Power Dissipation	350	W
$P_D @ T_C = 100^\circ\text{C}$	Maximum Power Dissipation	140	
T_J	Operating Junction and	-55 to + 150	$^\circ\text{C}$
T_{STG}	Storage Temperature Range		

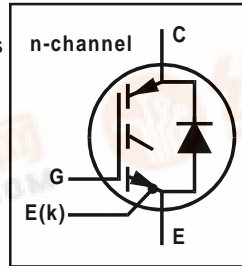

$V_{CES} = 600\text{V}$
$V_{CE(ON)typ} = 1.5\text{V}$
@ $V_{GE} = 15\text{V}, I_C = 50\text{A}$



Thermal Resistance

	Parameter	Min.	Typ.	Max.	Units
$R_{\theta JC}$	Junction-to-Case - IGBT	—	—	0.36	$^\circ\text{C/W}$
$R_{\theta JC}$	Junction-to-Case - Diode	—	—	0.69	
$R_{\theta CS}$	SMD-10 Case-to-Heatsink (typical), *	—	0.59	—	
Wt	Weight	—	6.0(0.21)	—	g (oz)

Notes: ① Repetitive rating: $V_{GE} = 20\text{V}$; pulse width limited by maximum junction temperature (figure 20)

② $V_{CE} = 80\%(V_{CES}), V_{GE} = 20\text{V}, L = 10\mu\text{H}, R_G = 5.0\Omega$ (figure 19)

③ Pulse width $\leq 80\mu\text{s}$; duty factor $\leq 0.1\%$.

④ Pulse width 5.0 μs , single shot.

* Assembly device soldered to 2.5mm Cu on 2.0mm IMS/Aluminum based, mounted to flat, spaced heatsink

IRG4ZC70UD

International
IR Rectifier

Electrical Characteristics @ $T_J = 25^\circ\text{C}$ (unless otherwise specified)

	Parameter	Min.	Typ.	Max.	Units	Conditions
$V_{(BR)CES}$	Collector-to-Emitter Breakdown Voltage ③	600	—	—	V	$V_{GE} = 0V, I_C = 250\mu A$
$\Delta V_{(BR)CES}/\Delta T_J$	Temperature Coeff. of Breakdown Voltage	—	0.36	—	V/ $^\circ\text{C}$	$V_{GE} = 0V, I_C = 1.0mA$
$V_{CE(on)}$	Collector-to-Emitter Saturation Voltage	—	1.49	1.9	V	$I_C = 50A, V_{GE} = 15V$
		—	1.80	—		$I_C = 100A$ see figure 2, 5
		—	1.47	—		$I_C = 50A, T_J = 150^\circ\text{C}$
$V_{GE(th)}$	Gate Threshold Voltage	3.0	—	6.0		$V_{CE} = V_{GE}, I_C = 250\mu A$
$\Delta V_{GE(th)}/\Delta T_J$	Temperature Coeff. of Threshold Voltage	—	-7.6	—	mV/ $^\circ\text{C}$	$V_{CE} = V_{GE}, I_C = 250\mu A$
g_{fe}	Forward Transconductance ④	34	52	—	S	$V_{CE} = 100V, I_C = 50A$
I_{CES}	Zero Gate Voltage Collector Current	—	—	250	μA	$V_{GE} = 0V, V_{CE} = 600V$
		—	—	1.3	mA	$V_{GE} = 0V, V_{CE} = 600V, T_J = 150^\circ\text{C}$
V_{FM}	Diode Forward Voltage Drop	—	1.24	1.5	V	$I_C = 50A$ see figure 13
		—	1.16	1.3		$I_C = 50A, T_J = 150^\circ\text{C}$
I_{GES}	Gate-to-Emitter Leakage Current	—	—	± 100	nA	$V_{GE} = \pm 20V$

Switching Characteristics @ $T_J = 25^\circ\text{C}$ (unless otherwise specified)

	Parameter	Min.	Typ.	Max.	Units	Conditions	
Q_g	Total Gate Charge (turn-on)	—	430	640	nC	$I_C = 50A$ $V_{CC} = 400V$ see figure 8 $V_{GE} = 15V$	
Q_{ge}	Gate - Emitter Charge (turn-on)	—	48	72			
Q_{gc}	Gate - Collector Charge (turn-on)	—	130	190			
$t_{d(on)}$	Turn-On Delay Time	—	71	—	ns	$T_J = 25^\circ\text{C}$ $I_C = 50A, V_{CC} = 480V$ $V_{GE} = 15V, R_G = 5.0\Omega$ Energy losses include "tail" and diode reverse recovery. see figures 9, 10, 18	
t_r	Rise Time	—	41	—			
$t_{d(off)}$	Turn-Off Delay Time	—	250	370			
t_f	Fall Time	—	110	220			
E_{on}	Turn-On Switching Loss	—	1.59	—	mJ	$T_J = 150^\circ\text{C}$, see figures 11, 18 $I_C = 50A, V_{CC} = 480V$ $V_{GE} = 15V, R_G = 5.0\Omega$ Energy losses include "tail" and diode reverse recovery.	
E_{off}	Turn-Off Switching Loss	—	1.78	—			
E_{ts}	Total Switching Loss	—	3.37	4.7			
$t_{d(on)}$	Turn-On Delay Time	—	68	—	ns	$T_J = 150^\circ\text{C}$, see figures 11, 18 $I_C = 50A, V_{CC} = 480V$ $V_{GE} = 15V, R_G = 5.0\Omega$ Energy losses include "tail" and diode reverse recovery.	
t_r	Rise Time	—	43	—			
$t_{d(off)}$	Turn-Off Delay Time	—	370	—			
t_f	Fall Time	—	130	—			
E_{ts}	Total Switching Loss	—	4.5	—	mJ		
L_E	Internal Emitter Inductance	—	2.0	—	nH		
C_{ies}	Input Capacitance	—	7400	—	pF	$V_{GE} = 0V$ $V_{CC} = 30V$ see figure 7 $f = 1.0MHz$	
C_{oes}	Output Capacitance	—	730	—			
C_{res}	Reverse Transfer Capacitance	—	90	—			
t_{rr}	Diode Reverse Recovery Time	—	90	140	ns	$T_J = 25^\circ\text{C}$ see figure 14 $T_J = 125^\circ\text{C}$ 14	$I_F = 50A$ $V_R = 200V$ di/dt = 200A/ μs
		—	120	180			
I_{rr}	Diode Peak Reverse Recovery Current	—	7.3	11	A	$T_J = 25^\circ\text{C}$ see figure 15 $T_J = 125^\circ\text{C}$ 15	
		—	11	16			
Q_{rr}	Diode Reverse Recovery Charge	—	360	550	nC	$T_J = 25^\circ\text{C}$ see figure 16 $T_J = 125^\circ\text{C}$ 16	
		—	780	1200			
$di_{(rec)M}/dt$	Diode Peak Rate of Fall of Recovery During t_b	—	370	—	A/ μs	$T_J = 25^\circ\text{C}$ see figure 17 $T_J = 125^\circ\text{C}$ 17	
		—	220	—			

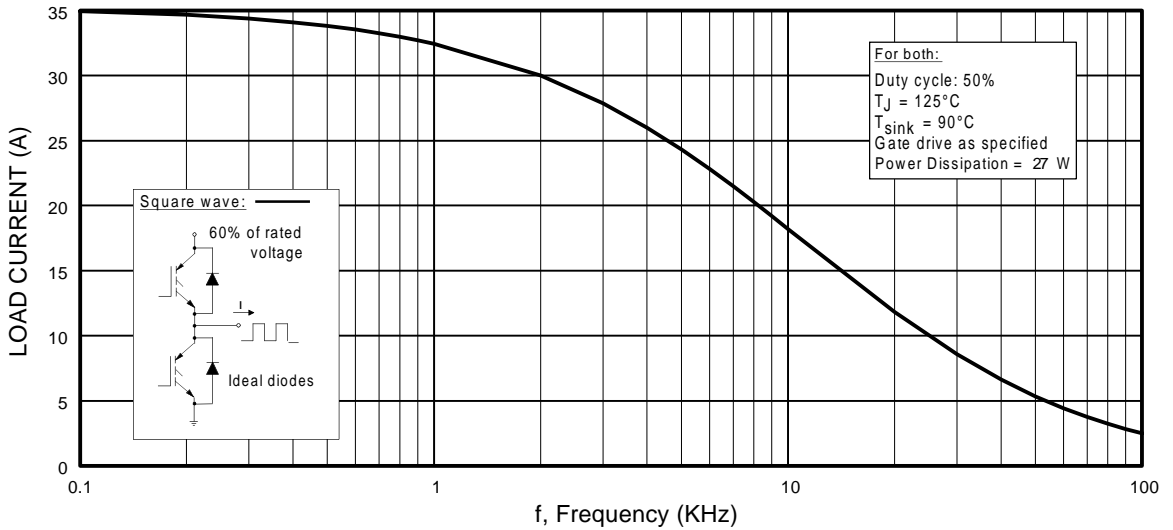

Fig. 1 - Typical Load Current vs. Frequency
 (Load Current = I_{RMS} of fundamental)

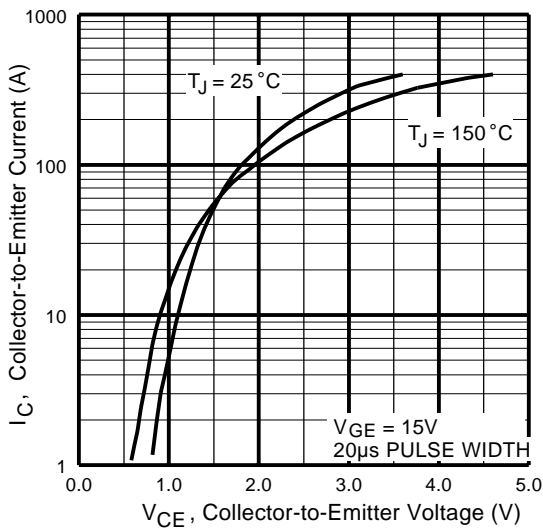

Fig. 2 - Typical Output Characteristics

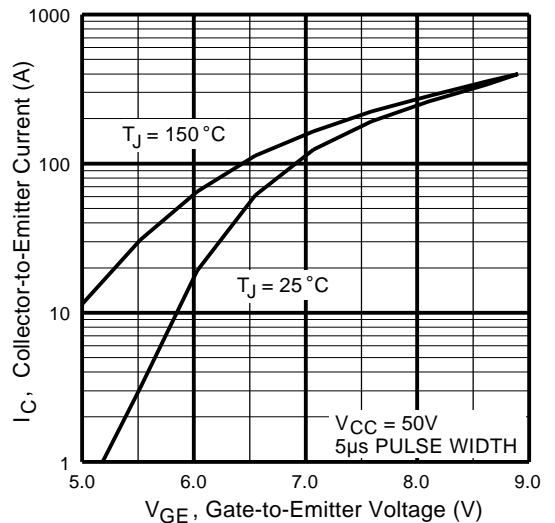

Fig. 3 - Typical Transfer Characteristics

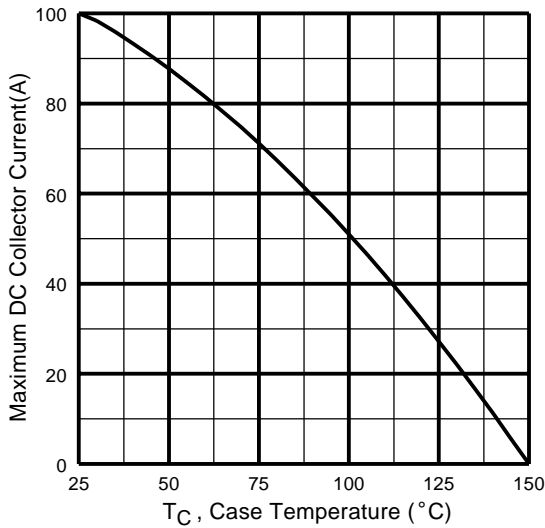

Fig. 4 - Maximum Collector Current vs. Case Temperature

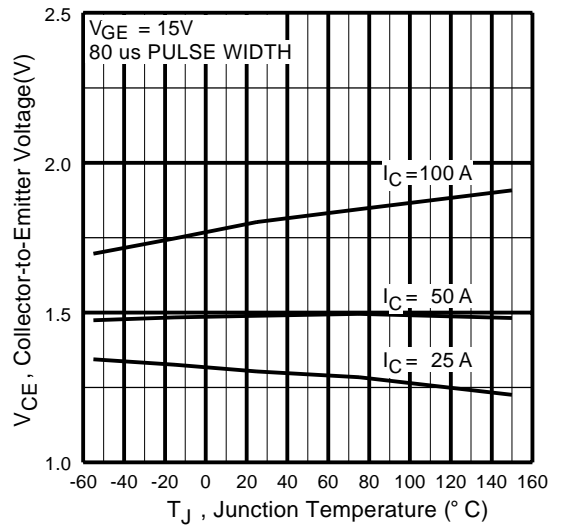

Fig. 5 - Typical Collector-to-Emitter Voltage vs. Junction Temperature

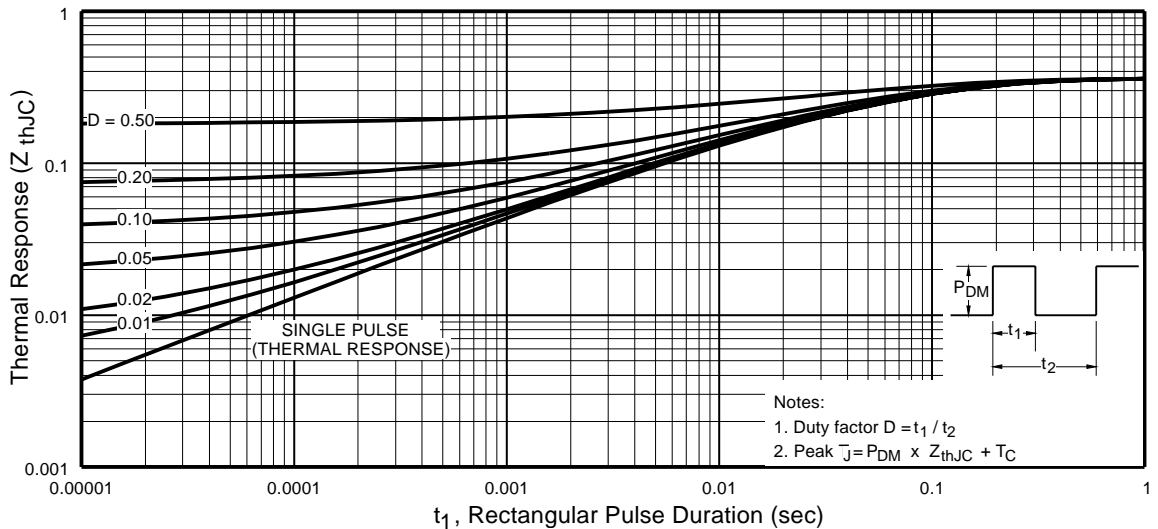

Fig. 6 - Maximum Effective Transient Thermal Impedance, Junction-to-Case

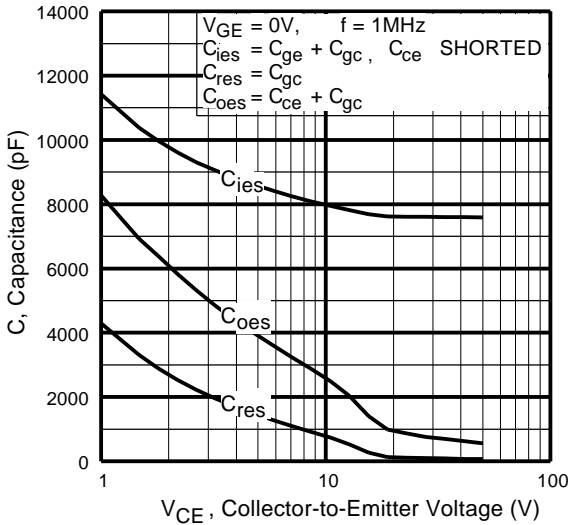

Fig. 7 - Typical Capacitance vs. Collector-to-Emitter Voltage

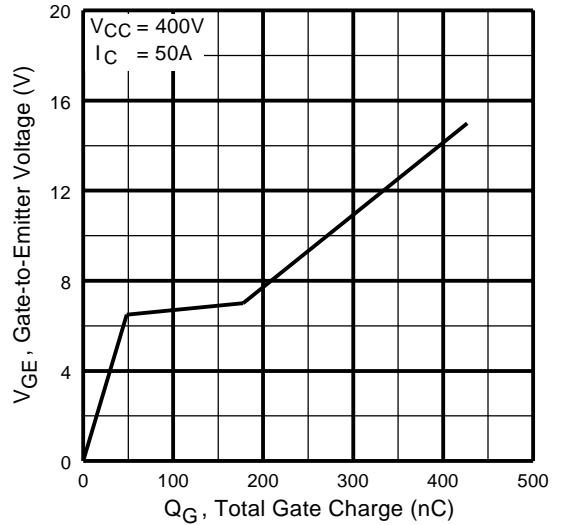

Fig. 8 - Typical Gate Charge vs. Gate-to-Emitter Voltage

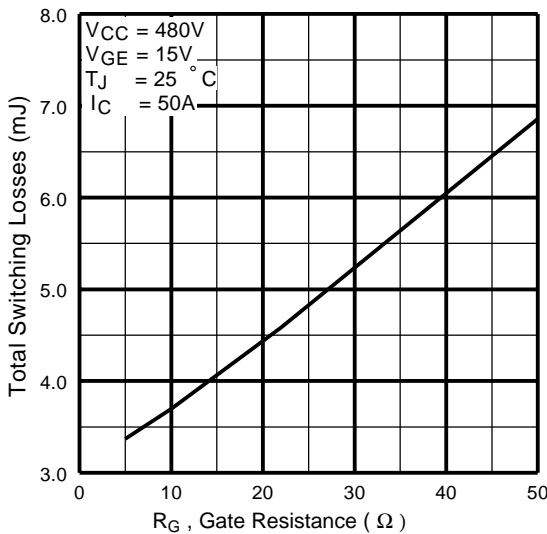

Fig. 9 - Typical Switching Losses vs. Gate Resistance

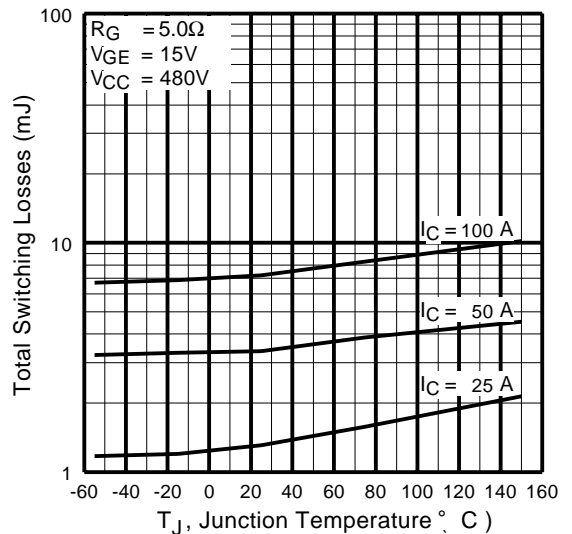

Fig. 10 - Typical Switching Losses vs. Junction Temperature

IRG4ZC70UD

International
IR Rectifier

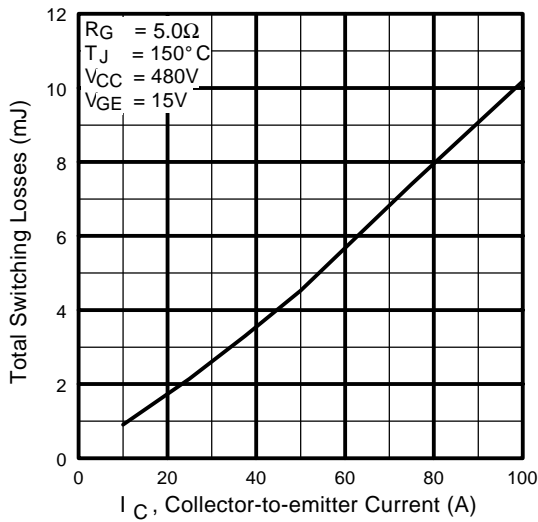

Fig. 11 - Typical Switching Losses vs. Collector-to-Emitter Current

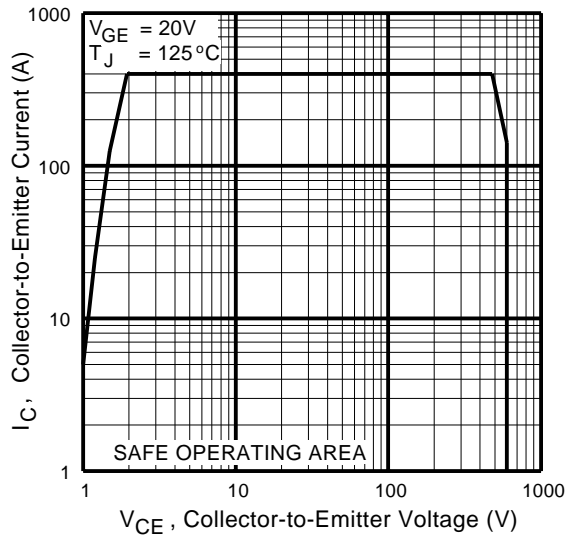

Fig. 12 - Turn-Off SOA

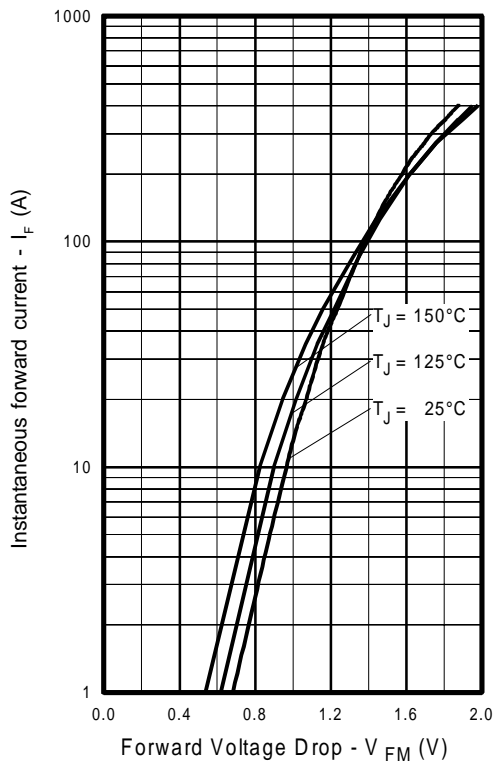

Fig. 13 - Typical Forward Voltage Drop vs. Instantaneous Forward Current

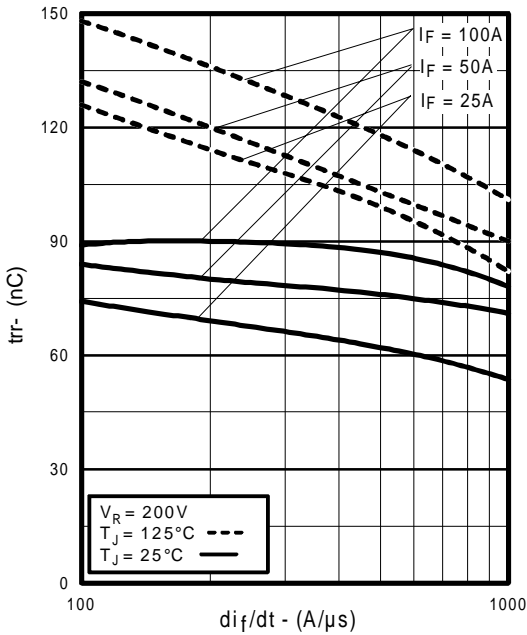

Fig. 14 - Typical Reverse Recovery vs. di_f/dt

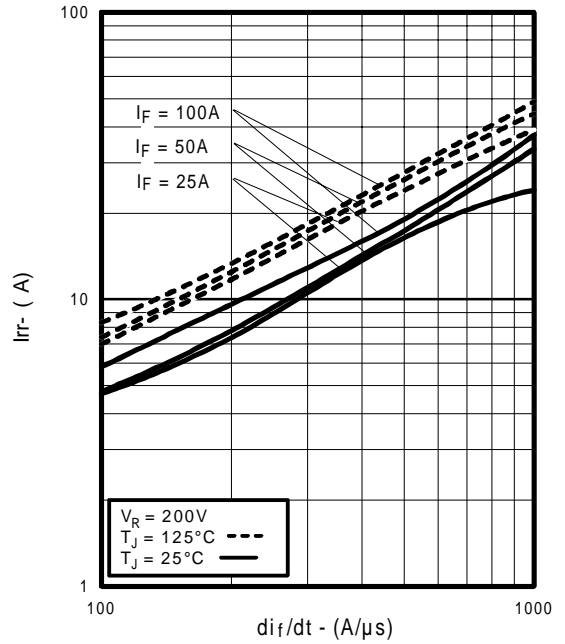

Fig. 15 - Typical Recovery Current vs. di_f/dt

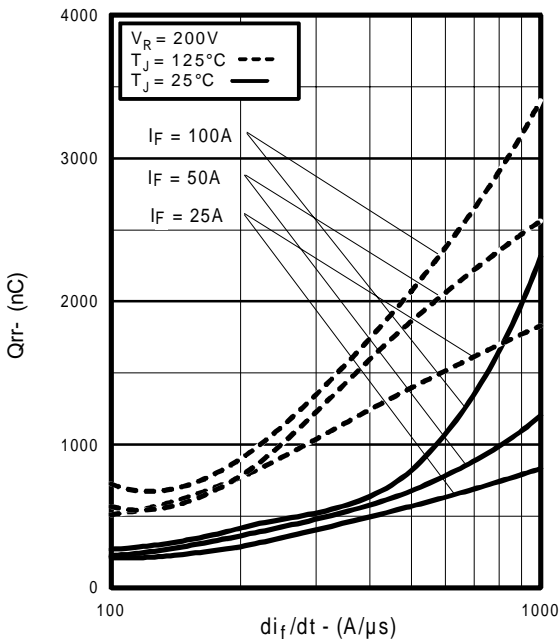

Fig. 16 - Typical Stored Charge vs. di_f/dt

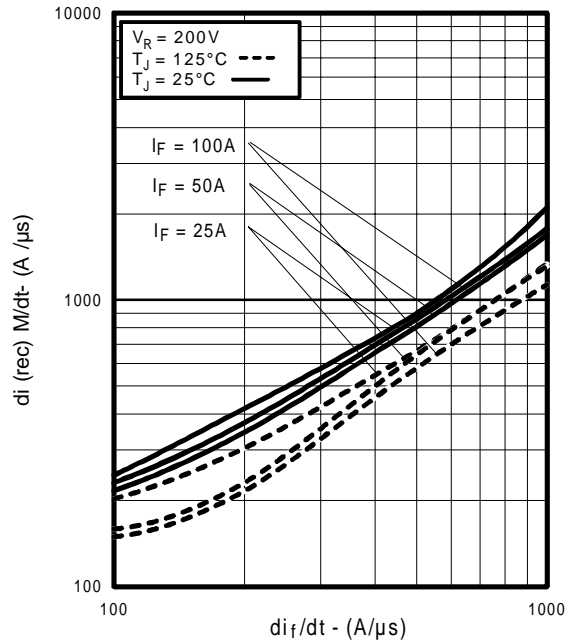

Fig. 17 - Typical $di_{(rec)M}/dt$ vs. di_f/dt

IRG4ZC70UD

International
IOR Rectifier

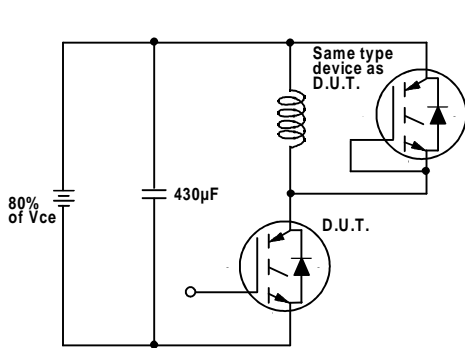

Fig. 18a - Test Circuit for Measurement of I_{LM} , E_{on} , $E_{off}(\text{diode})$, t_{rr} , Q_{rr} , I_{rr} , $t_{d(on)}$, t_r , $t_{d(off)}$, t_f

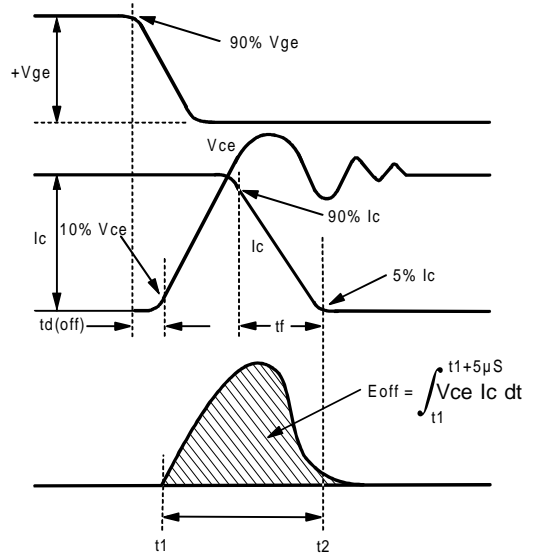

Fig. 18b - Test Waveforms for Circuit of Fig. 18a, Defining E_{off} , $t_{d(off)}$, t_f

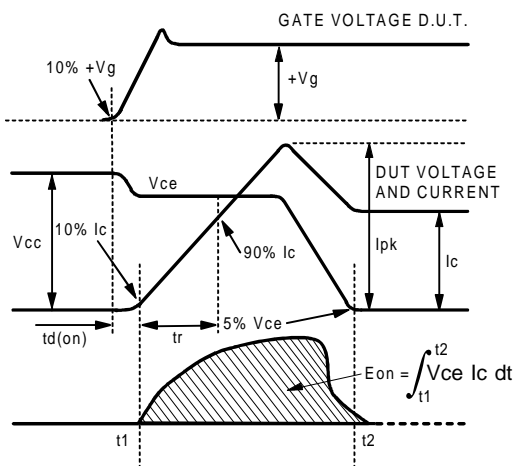

Fig. 18c - Test Waveforms for Circuit of Fig. 18a, Defining E_{on} , $t_{d(on)}$, t_r

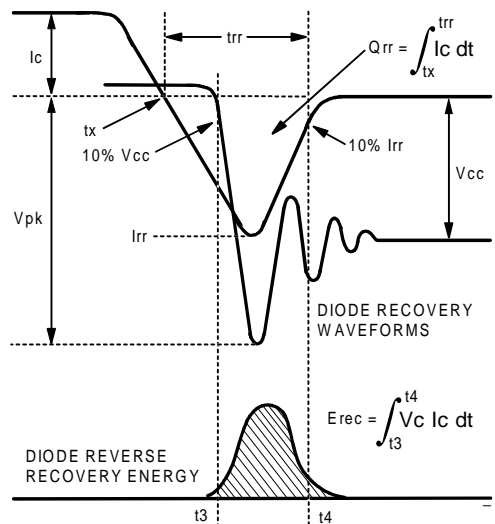

Fig. 18d - Test Waveforms for Circuit of Fig. 18a, Defining E_{rec} , t_{rr} , Q_{rr} , I_{rr}

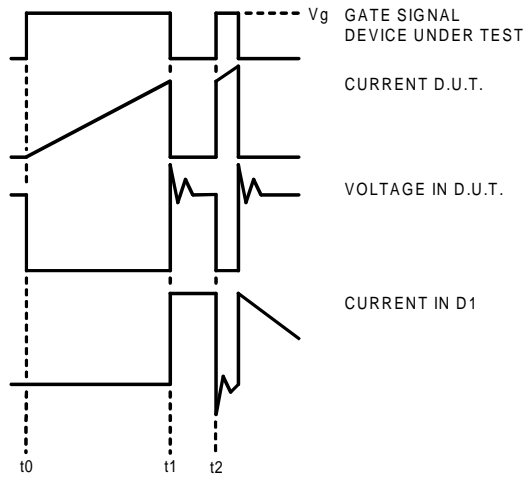

Figure 18e. Macro Waveforms for Figure 18a's Test Circuit

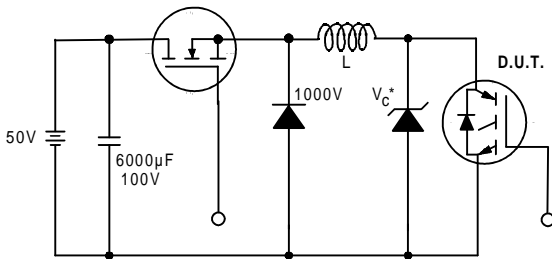

Figure 19. Clamped Inductive Load Test Circuit

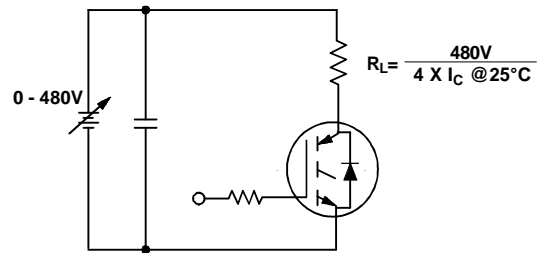

Figure 20. Pulsed Collector Current Test Circuit

IRG4ZC70UD

International
IR Rectifier

Case Outline — SMD-10

Dimensions are shown in millimeters

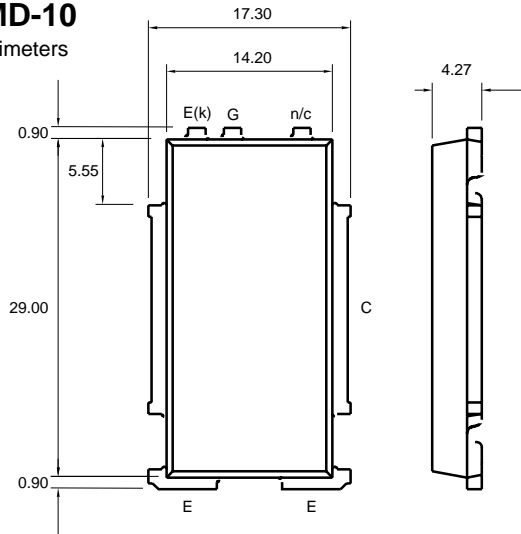

Recommended footprint

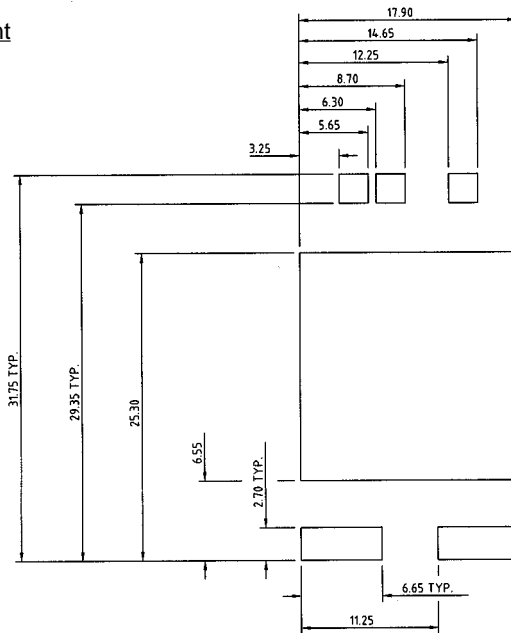

International
IR Rectifier

WORLD HEADQUARTERS: 233 Kansas St., El Segundo, California 90245, Tel: (310) 322 3331

EUROPEAN HEADQUARTERS: Hurst Green, Oxted, Surrey RH8 9BB, UK Tel: ++ 44 1883 732020

IR CANADA: 7321 Victoria Park Ave., Suite 201, Markham, Ontario L3R 2Z8, Tel: (905) 475 1897

IR GERMANY: Saalburgstrasse 157, 61350 Bad Homburg Tel: ++ 49 6172 96590

IR ITALY: Via Liguria 49, 10071 Borgaro, Torino Tel: ++ 39 11 451 0111

IR FAR EAST: K&H Bldg., 2F, 30-4 Nishi-Ikebukuro 3-Chome, Toshima-Ku, Tokyo Japan 171 Tel: 81 3 3983 0086

IR SOUTHEAST ASIA: 315 Outram Road, #10-02 Tan Boon Liat Building, Singapore 0316 Tel: 65 221 8371

<http://www.irf.com/> Data and specifications subject to change without notice. 3/98