



**SINGLE SUPPLY  
QUAD PECL-TO-TTL  
OUTPUT ENABLE**

**ClockWorks™  
SY10H842  
SY100H842**

**FEATURES**

- Translates positive ECL-to-TTL (PECL-to-TTL)
- 300ps pin-to-pin skew
- 500ps part-to-part skew
- Differential internal design for increased noise immunity and stable threshold inputs
- VBB reference output
- Single supply
- Enable input
- Extra TTL and ECL power/ground pins to reduce cross-talk/noise
- High drive capability: 24mA each output
- Fully compatible with industry standard 10K, 100K I/O levels
- Available in 16-pin SOIC package

**DESCRIPTION**

The SY10/100H842 are single supply, low skew translating 1:4 clock drivers.

The devices feature a 24mA TTL output stage, with AC performance specified into a 50pF load capacitance. A HIGH on the enable pin ( $\overline{EN}$ ) forces all outputs LOW.

As frequencies increase to 40MHz and above, precise timing and shaping of clock signals becomes extremely important. The H842 solves several clock distribution problems such as minimizing skew (300ps), maximizing clock fanout (24mA drive), and precise duty cycle control through a proprietary differential internal design.

The 10K version is compatible with 10KH ECL logic levels. The 100K version is compatible with 100K levels.

**BLOCK DIAGRAM**

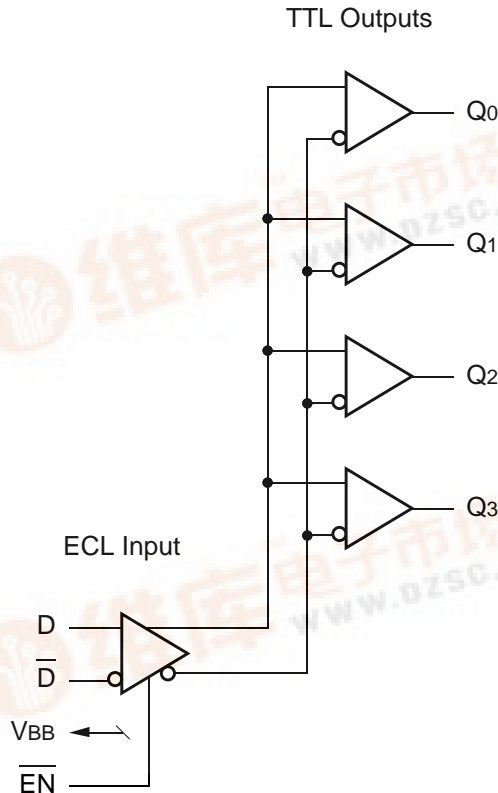

**PIN CONFIGURATION**

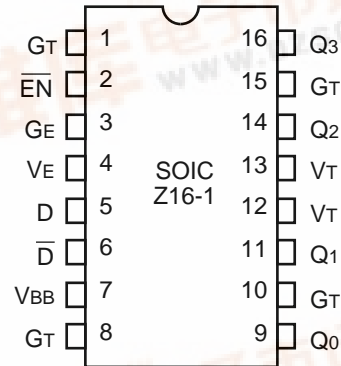

**PIN NAMES**

Pin	Function
GT	TTL Ground (0V)
VT	TTL Vcc (+5.0V)
VE	ECL Vcc (+5.0V)
GE	ECL Ground (0V)
D, $\overline{D}$	Signal Input (PECL)
VBB	VBB Reference Output (PECL)
Q0 - Q3	Signal Outputs (TTL)
$\overline{EN}$	Enable Input (PECL)



**TRUTH TABLE**

D	EN	Q
L	L	L
H	L	H
X	H	L

**ABSOLUTE MAXIMUM RATINGS<sup>(1)</sup>**

Symbol	Rating	Value	Unit
VE (ECL) VT (TTL)	Power Supply Voltage	-0.5 to +7.0 -0.5 to +7.0	V
VI (ECL) VOUT (TTL)	Input Voltage	0.0 to VEE 0.0 to VT	V
Tstore	Storage Temperature	-65 to +150	°C
TA	Operating Temperature	0 to +85	°C

**NOTE:**

1. Permanent device damage may occur if ABSOLUTE MAXIMUM RATINGS are exceeded. This is a stress rating only and functional operation is not implied at conditions other than those detailed in the operational sections of this data sheet. Exposure to ABSOLUTE MAXIMUM RATING conditions for extended periods may affect device reliability.

**PIN DESCRIPTION**

Pin	Symbol	Description
1	GT	TTL Ground (0V)
2	EN	Enable Input (PECL)
3	GE	ECL Ground (0V)
4	VE	ECL Vcc (+5.0V)
5	D	ECL Signal Input (Non-inverting)
6	D̄	ECL Signal Input (Inverting)
7	VBB	VBB Reference Output (PECL)
8	GT	TTL Ground (0V)
9	Q0	Signal Output (TTL)
10	GT	TTL Ground (0V)
11	Q1	Signal Output (TTL)
12	VT	TTL Vcc (+5.0V)
13	VT	TTL Vcc (+5.0V)
14	Q2	Signal Output (TTL)
15	GT	TTL Ground (0V)
16	Q3	Signal Output (TTL)

**VCC AND CLOAD**

Ranges to meet duty cycle requirement:  $0^{\circ}\text{C} \leq T_A \leq 85^{\circ}\text{C}$ . Output duty cycle measured relative to 1.5V.

Symbol	Parameter		Min.	Typ.	Max.	Unit	Condition
Pw	Ranges of Vcc and CL to meet min. pulse width (HIGH or LOW) at $f_{\text{OUT}} \leq 40\text{MHz}$	Vcc	4.75	5.0	5.25	V	All Outputs
		CL	10	—	50	pF	
		Pw	11	—	—	ns	
Pw	Ranges of Vcc and CL to meet min. pulse width (HIGH or LOW) at $f_{\text{OUT}} \leq 50\text{MHz}$	Vcc	4.875	5.0	5.125	V	All Outputs
		CL	15	—	27	pF	
		Pw	9.0	—	—	ns	

**DC CHARACTERISTICS**

$V_T = V_E = 5.0V \pm 5\%$

Symbol	Parameter		TA = 0°C		TA = +25°C		TA = +85°C		Unit	Condition
			Min.	Max.	Min.	Max.	Min.	Max.		
IEE	Power Supply Current	ECL	—	35	—	35	—	35	mA	VE Pin
ICCH	Power Supply Current	TTL	—	20	—	20	—	20	mA	Total all VT pins
ICCL			—	25	—	25	—	25		

**TTL DC ELECTRICAL CHARACTERISTICS**

VT = VE = +5.0V ± 5%

Symbol	Parameter	TA = 0°C		TA = +25°C		TA = +85°C		Unit	Condition
		Min.	Max.	Min.	Max.	Min.	Max.		
VOH	Output HIGH Voltage	2.5 2.0	— —	2.5 2.0	— —	2.5 2.0	— —	V	I <sub>OH</sub> = -3.0mA I <sub>OH</sub> = -15mA
VOL	Output LOW Voltage	—	0.5	—	0.5	—	0.5	V	I <sub>OL</sub> = 24mA
I <sub>OS</sub>	Output Short Circuit Current	-80	-200	-80	-200	-80	-200	mA	V <sub>OUT</sub> = 0V

**10H ECL DC ELECTRICAL CHARACTERISTICS<sup>(1)</sup>**

VT = VE = +5.0V ± 5%

Symbol	Parameter	TA = 0°C		TA = +25°C		TA = +85°C		Unit	Condition
		Min.	Max.	Min.	Max.	Min.	Max.		
I <sub>IH</sub>	Input HIGH Current	—	225	—	175	—	175	μA	—
I <sub>IL</sub>	Input LOW Current	0.5	—	0.5	—	0.5	—	μA	—
V <sub>IH</sub>	Input HIGH Voltage	3.830	4.160	3.870	4.190	3.940	4.280	V	VE = 5.0V
V <sub>IL</sub>	Input LOW Voltage	3.050	3.520	3.050	3.520	3.050	3.555	V	VE = 5.0V
V <sub>BB</sub>	Output Reference Voltage	3.620	3.730	3.650	3.750	3.690	3.810	V	VE = 5.0V

**NOTE:**1. ECL V<sub>IH</sub>, V<sub>IL</sub> and V<sub>BB</sub> are referenced to V<sub>CC</sub>E and will vary 1:1 with the power supply. The levels shown are for I<sub>VT</sub> = I<sub>VO</sub> = V<sub>CC</sub>E = +5.0V.**100H ECL DC ELECTRICAL CHARACTERISTICS<sup>(1)</sup>**

VT = VE = +5.0V ± 5%

Symbol	Parameter	TA = 0°C		TA = +25°C		TA = +85°C		Unit	Condition
		Min.	Max.	Min.	Max.	Min.	Max.		
I <sub>IH</sub>	Input HIGH Current	—	225	—	175	—	175	μA	—
I <sub>IL</sub>	Input LOW Current	0.5	—	0.5	—	0.5	—	μA	—
V <sub>IH</sub>	Input HIGH Voltage	3.835	4.120	3.835	4.12	3.835	4.120	V	VE = 5.0V
V <sub>IL</sub>	Input LOW Voltage	3.190	3.525	3.1900	3.525	3.190	3.525	V	VE = 5.0V
V <sub>BB</sub>	Output Reference Voltage	3.620	3.740	3.62	3.740	3.620	3.740	V	VE = 5.0V

**NOTE:**1. ECL V<sub>IH</sub>, V<sub>IL</sub> and V<sub>BB</sub> are referenced to V<sub>CC</sub>E and will vary 1:1 with the power supply. The levels shown are for I<sub>VT</sub> = I<sub>VO</sub> = V<sub>CC</sub>E = +5.0V.

**AC CHARACTERISTICS**

VT = VE = 5.0V ± 5%

Symbol	Parameter		TA = 0°C		TA = +25°C		TA = +85°C		Unit	Condition
			Min.	Max.	Min.	Max.	Min.	Max.		
tPLH tPHL	Propagation Delay D to Output	Q0–Q3	2.5	3.5	2.5	3.5	2.5	3.5	ns	CL = 50pF
tskpp	Part-to-Part Skew <sup>(1,4)</sup>	Q0–Q3	—	0.5	—	0.5	—	0.5	ns	CL = 50pF
tskew++	Within-Device Skew <sup>(2,4)</sup>	Q0–Q3	—	0.3	—	0.3	—	0.3	ns	CL = 50pF
tskew--	Within-Device Skew <sup>(3,4)</sup>	Q0–Q3	—	0.3	—	0.3	—	0.3	ns	CL = 50pF
tPLH tPHL	Propagation Delay EN to Output	Q0–Q3	2.5	3.5	2.5	3.5	2.5	3.5	ns	CL = 50pF
tr tf	Output Rise/Fall Time 1.0V to 2.0V	Q0–Q3	—	1.5	—	1.5	—	1.5	ns	CL = 50pF
fMAX	Max. Input Frequency <sup>(5,6)</sup>	Q0–Q3	160	—	160	—	160	—	MHz	CL = 50pF

**NOTES:**

1. Device-to-Device Skew considering HIGH-to-HIGH transitions at common Vcc level.
2. Within-Device Skew considering HIGH-to-HIGH transitions at common Vcc level.
3. Within-Device Skew considering LOW-to-LOW transitions at common Vcc level.
4. All skew parameters are guaranteed but not tested.
5. Frequency at which output levels will meet a 0.8V to 2.0V minimum swing.
6. The fMAX value is specified as the minimum guaranteed maximum frequency. Actual operational maximum frequency may be greater.

**PRODUCT ORDERING CODE**

Ordering Code	Package Type	Operating Range
SY10H842ZC	Z16-1	Commercial
SY10H842ZCTR	Z16-1	Commercial
SY100H842ZC	Z16-1	Commercial
SY100H842ZCTR	Z16-1	Commercial

### TTL SWITCHING CIRCUIT

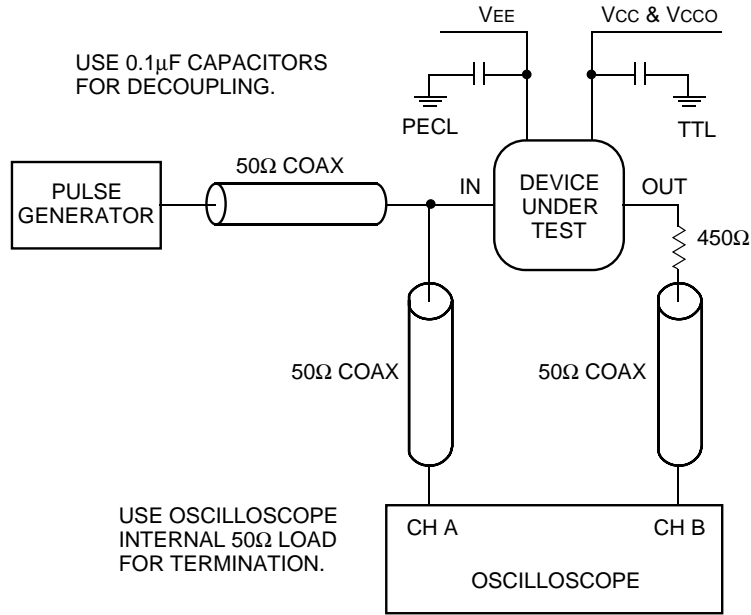

### ECL/TTL PROPAGATION DELAY — SINGLE ENDED

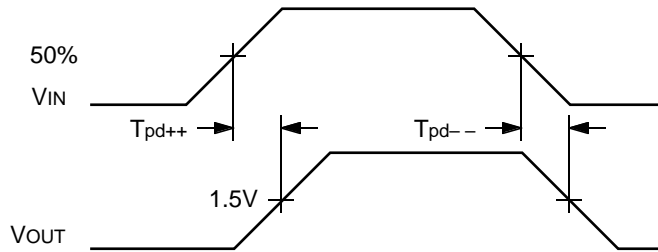

### ECL/TTL WAVEFORMS: RISE AND FALL TIMES

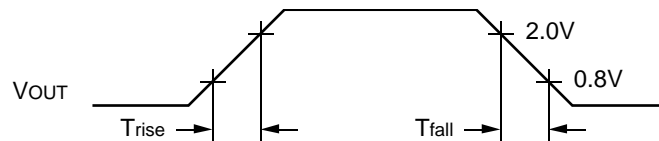

**16 LEAD SOIC .300" WIDE (Z16-1)**

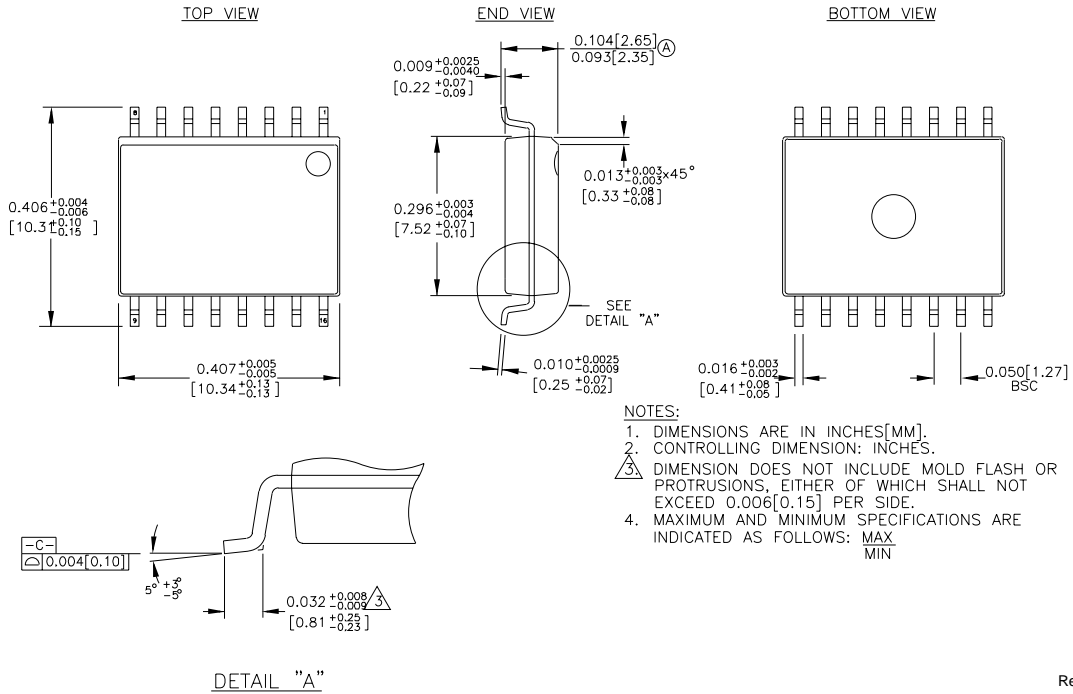

Rev. 03