



ZL10310/ZL10311  
**Digital Television DVB-T-On-a-Chip Processor**  
 Data Sheet

**Features**

- DTV-SoC for Digital Terrestrial Television (DTT)
- On-chip DVB-T COFDM demodulator with FEC.
- 6 Video DACs on-chip, for Composite or Component (RGB or Y U/V) Analog Video
- Twin PAL/NTSC DENCs
- Low Power (<1.4W Typical)
- Low Component Count
- Unified SDRAM controller
- I<sup>2</sup>S Digital Audio Input
- I<sup>2</sup>S and S/PDIF Digital Audio outputs
- MPEG-2 Audio & Video decoders
- PowerPC 405™ CPU Core with 16k/16k cache, Memory manager and Virtual memory system
- Complete Linux-based Software Development Kit (SDK)
- IDE interface
- Inputs for external MPEG-2 Transport Streams, allowing support for external demodulators (e.g. Cable TV, Satellite TV)
- Conditional Access (CA) DVB-descrambler

Issue 1.0

November 2002

Ordering Information	
ZL10310/GAC	388 ball EPBGA
ZL10311/GAC	388 ball EPBGA
<b>0°C to +70°C</b>	

- Smart Card Interface
- Infrared & UART interface
- DVB-compatible Common Interface (CI) control and bitstream interfaces
- Multi-stream multiplexing to support internal and external demodulators
- External Modem support interface
- Supports Macrovision™ Copy Protection - (ZL10311 only; available to Macrovision license holders only)
- Dolby® Digital\* Decoding - (ZL10311 only; available to Dolby® Digital\* license holders only - \*awaiting certification)

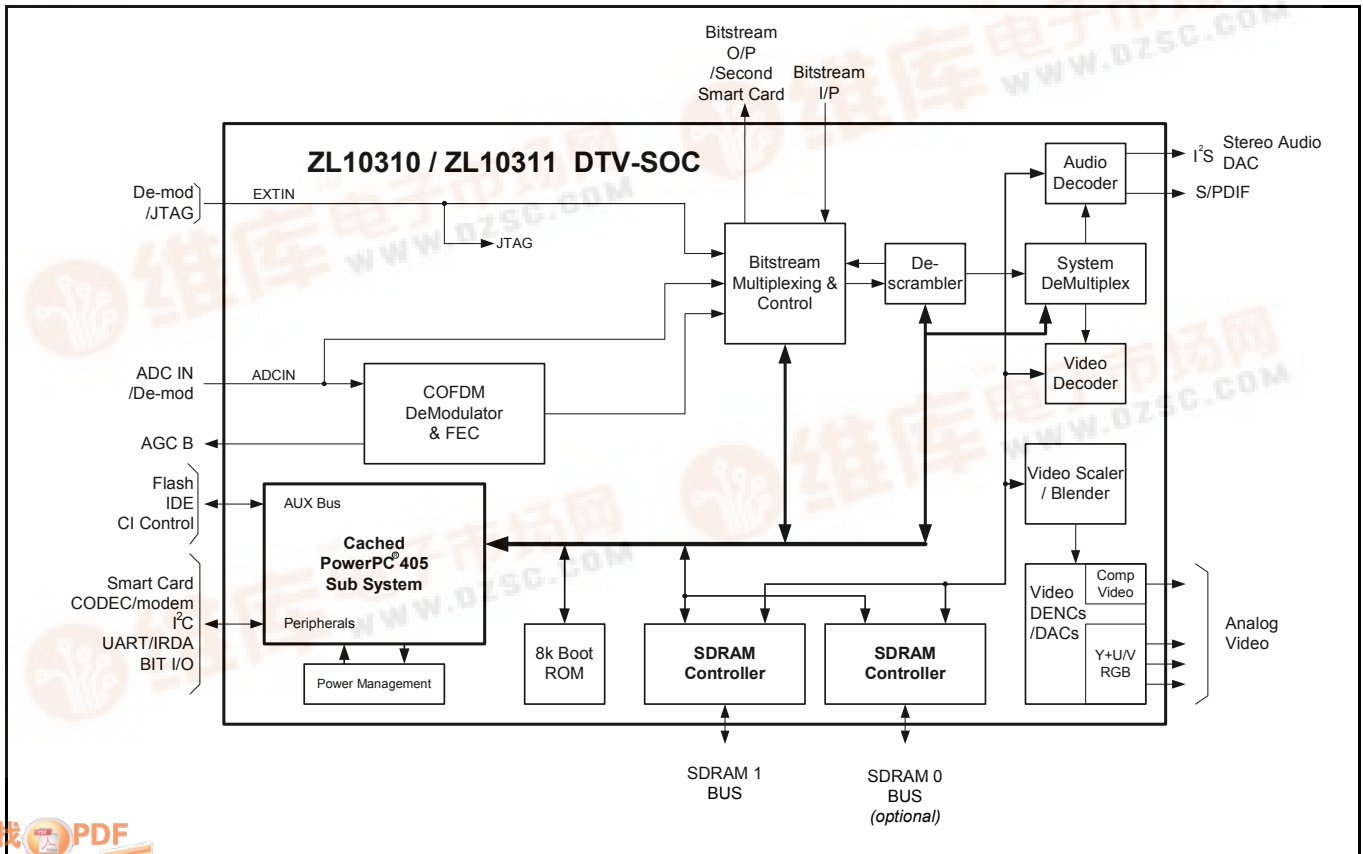

Figure 1 - Block Diagram of ZL10310 and ZL10311



## Applications

- Low power, small footprint TV adaptors
- Integrated Digital Televisions (iDTV)
- Digital terrestrial set-top boxes
- DTT / DVD Combo
- DVB-T radio receivers
- Terrestrial / Satellite Combo
- Terrestrial / Cable Combo
- Terrestrial / IP (Internet Protocol) Combo

## Description

Zarlink Semiconductor has responded to market demand by integrating its key DVB-T compliant COFDM demodulation technology with Set Top Box functionality (MPEG-2 AV decoder and system interfaces) together with a high performance CPU to offer a “DVB-T On-a-Chip” solution.

The ZL10310 DVB-T On-a-Chip, can address a wide range of DVB-T consumer electronic products. At the entry level it can be used to build ultra-compact Free-To-View Digital TV adaptors (such as for FreeView in the UK), yet consumes less than 4W of power in full operational mode.

This level of compactness also considerably eases the integration of DVB-T receiver technology inside integrated Digital TV sets (iDTV's) where space considerations and thermal management are key design issues.

The ZL10310 is based upon an industry standard PowerPC 405™ RISC processor, which has Virtual and Memory Management sub-systems. This permits the device to be effectively deployed in compelling applications such as interactive Digital TV which are able to exploit the superior processing performance offered by the PowerPC® processor core.

The PowerPC® provides an ideal platform for running robust open standard operating systems such as Linux which can benefit system developers in a number of key areas:

- Unified software development environment, from entry level basic channel zapper systems through to fully interactive high performance Digital Set Top Boxes.
- Re-use of software code from multiple projects
- Exploit software code developed in the Linux community.
- Low cost-per-seat software development environment.
- Familiar software development environment.
- Royalty free.

Also available is the ZL10311 DVB-T On-a-Chip, which additionally offers Dolby® Digital<sup>1</sup> multi-channel audio decoding, and Macrovision™ Copy Protection for applications requiring Dolby® Audio and Pay TV services.

---

1. The ZL10311 device is awaiting Dolby Certification

---

## Table of Contents

<b>1.0 Device Overview</b> .....	<b>4</b>
<b>2.0 Device Interfaces</b> .....	<b>4</b>
<b>3.0 Typical Digital Television (DTV) Receiver</b> .....	<b>5</b>
<b>4.0 Functional Blocks Overview</b> .....	<b>6</b>
4.1 Boot ROM .....	6
4.2 Clock Generation Block .....	6
4.3 Coded Orthogonal Frequency Division Multiplex (COFDM) Demodulator .....	7
4.4 MPEG Audio Decoder .....	7
4.5 MPEG-2 Video Decoder .....	8
4.6 PowerPC 405™ Processor .....	8
4.7 Transport Engine .....	9
4.8 Video Display System .....	9
<b>5.0 Physical Specification</b> .....	<b>10</b>
<b>6.0 ZL10310/ZL10311 388-pin Package Pin Descriptions</b> .....	<b>11</b>
6.1 Pin Types .....	11
6.2 Front End Interfaces .....	11
6.3 Video DAC Outputs .....	14
6.4 SDRAM Interfaces .....	15
6.5 Bit Stream Interfaces .....	17
6.6 Auxiliary External Bus .....	21
6.7 Peripheral Port .....	24
6.8 Modem/Codec Interface .....	26
6.9 Smart Card Interface .....	28
6.10 General Purpose Input Output Interfaces .....	28
6.11 Simplified General Purpose Input Output Interface .....	31
6.12 Inter Integrated Circuit (I2C) Interface .....	33
6.13 Inter IC Sound (I2S) Audio Interface .....	33
6.14 Clock and Reset Interface .....	33
6.15 Power Supply Pins .....	34
6.16 Reserved Connections .....	35
<b>7.0 Characteristics</b> .....	<b>36</b>
7.1 AC and DC Electrical Characteristics .....	36

IBM®, the IBM Logo, PowerPC® and PowerPC405™ are trademarks of International Business Machines Corporation.

Dolby® is a trademark of Dolby Laboratories. Supply of this implementation of Dolby Technology does not convey a license or imply a right under any patent, or any other Industrial or Intellectual Property Right of Dolby Laboratories, to use this implementation in any finished end-user or ready-to-use final product. It is hereby notified that a license for such use is required from Dolby Laboratories<sup>1</sup>.

This device is protected by US patent numbers 4631603, 4577216 and 4819098 and other intellectual property rights. Use of the Macrovision anticopy process in the device is licensed by Macrovision for non-commercial, home and limited exhibition use only. Reverse engineering or disassembly is prohibited. A valid Macrovision license must be in effect between the purchaser of the ZL10311 IC and Macrovision Corporation. Additional per-chip royalties may be required and are payable by the purchaser to Macrovision.

<sup>1</sup> The ZL10311 device is awaiting Dolby Certification

## 1.0 Device Overview

Zarlink Semiconductor has designed the ZL10310 and ZL10311 System On a Chip (SoC) devices specifically for DVB-T applications. Integrating a high performance PowerPC 405™ processor with robust industry proven MPEG-2 audio and video decoding, OSD and a COFDM demodulator, the ZL10310 and ZL10311 deliver the performance and functionality required for advanced Digital TV entertainment products. It enables the rapid design and manufacture of cost-effective iDTV and Digital Audio Visual Home Entertainment Centers.

The enhanced ZL10311 also supports DVD playback with up to six Dolby® Digital<sup>1</sup> audio channels. In addition, by integrating the COFDM demodulator, the ZL10310 and ZL10311 enable the implementation of very small footprint TV Adaptor modules.

## 2.0 Device Interfaces

The following peripheral interfaces are available to the user. Apart from possible level translation and connector buffering, no external devices are required to support any of the interfaces.

- 10-bit input that may be configured for an ADC input to the internal COFDM demodulator
- Additional input bus for additional MPEG-2 Transport Sources
- AGC (PWM) outputs for a terrestrial tuner
- Serial control port for a digital tuners
- Common interface control and bitstream interfaces for an external descrambler
- Normal PC (PCMCIA) memory module interface for local software updates
- Unified 64 Mbit SDRAM interface for all decoders and PowerPC 405™
- Additional SDRAM interface for high end systems requiring increased memory bandwidth
- Static memory interface for Flash and external peripherals
- IDE/ATAPI interface for hard disk and DVD drives
- External DMA channel and interrupts
- Six analog video outputs give full flexibility on RGB, S-VHS, and composite signals (with and without OSD)
- I<sup>2</sup>S input port from external Digital Stereo source
- Three I<sup>2</sup>S ports to external audio DACs for main, surround, and centre channels
- Dolby® surround sound control signals
- Sony/Philips Digital InterFace (S/PDIF)

If not required in a particular system, any of the peripheral interfaces can be replaced by individual I/O bits from internal general purpose registers. These can then be used for additional purpose, such as interfacing to switches and displays.

- Full RS232 interface to an external modem or a 4 wire interface to a Codec
- IRDA interface or an additional asynchronous serial interface
- Synchronous serial interface for EEPROM, etc.
- Two Smart card Interfaces (one instead of a Common Interface)
- General purpose I<sup>2</sup>C interface
- General purpose timer for Infrared (IR) decoding
- General purpose individual bit I/Os

---

1. The ZL10311 device is awaiting Dolby Certification

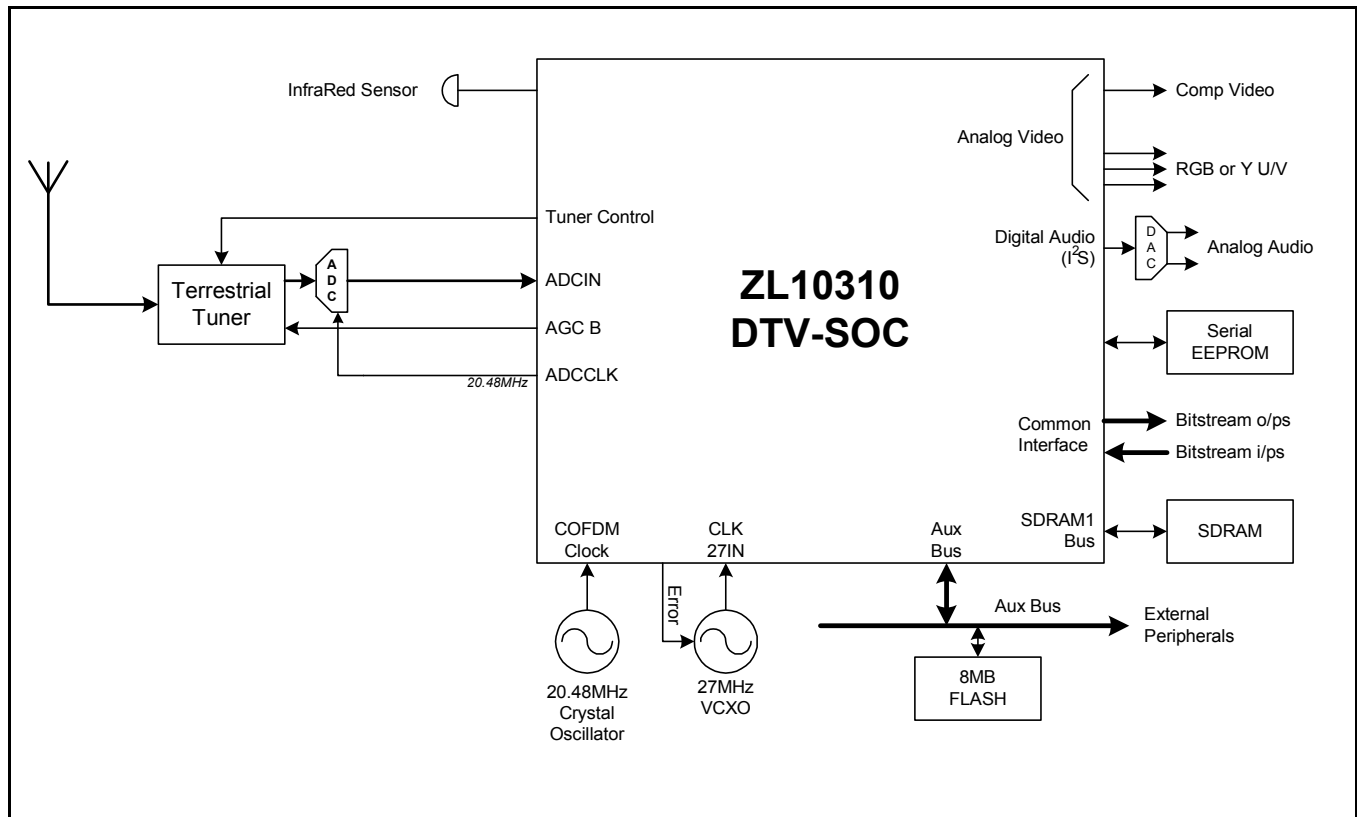

Figure 2 - Block diagram of a typical ZL10310-based Free to Air TV Adaptor

### 3.0 Typical Digital Television (DTV) Receiver

Figure 2 shows a typical Free to Air TV receiver block diagram employing a ZL10310 DTV-SoC device. In its minimal configuration, the ZL10310 DTV-SoC device only requires a single 64 Mbit SDRAM, an audio DAC, and a Flash ROM, which are in addition to a DVB-T tuner front end and a 10-bit analog to digital converter.

The Terrestrial Tuner section performs an independent down conversion of the received DVB-T signal from the Antenna, to an IF frequency in the range of 30MHz to 57MHz, dependent on television system (typically 36.17MHz Center Frequency, with  $\pm 4$ MHz span). The analogue IF is then converted to the digital domain, with a 10-bit ADC, clocked at 20.48MHz and the resulting Digital output is centered on 15.69MHz. This Digital signal is applied to the ZL10310 via the ADC\_IN[9:0] input pins, in the form of a 10-bit parallel signal.

The ZL10310 converts the digitized IF from a Terrestrial TV Tuner into an MPEG-2 Transport Stream, which can be optionally de-scrambled (if CA scrambling is used by the broadcaster), and de-multiplexed into separate Packetised Elementary Streams (PES), which are routed to the MPEG Audio and Video decoders, and SI data to the PowerPC 405™ subsystem.

Decoded Video can then be mixed and optionally scaled with On-Screen Display (OSD) Graphics generated by the DTV application software. The resultant combination of video and graphics are then routed to the PAL/NTSC Digital ENCOders (DENCs) for display on the TV via the on-chip 10-bit video DACs.

Decoded Audio is output directly from the audio decoder sub-system to the I<sup>2</sup>S and S/PDIF (Sony/Philips Digital InterFace) outputs.

## 4.0 Functional Blocks Overview

### 4.1 Boot ROM

Program execution on the Power PC<sup>®</sup> normally starts from address 0xFFFFF000 after the internal reset has gone inactive. This would normally be an address in the external Flash ROM (enabled by BI\_CS0), but, by forcing the SGPIO2\_3 pin low during reset, it is possible to boot from the Internal 8k Boot ROM. The ZL10310 and ZL10311 devices contain an 8k Boot ROM containing code, which is executed under the noted conditions above following a complete system reset (i.e. when main power has been removed from the ZL10310 or ZL10311).

The code installed on the Boot ROM, allows the ZL10310/ZL10311 to undertake any of the following 4 functions after a complete reset:

1. Enter ISP (in-system programmable) mode, in which the software in the internal Boot ROM will try booting from an SPI or I<sup>2</sup>C EEPROM.
2. Try booting from an Atmel Serial Flash device (AT45xxxx) first, if that fails then enter ISP mode.
3. Try booting from an asynchronous parallel flash device connected to the EBIU bus (CS0) first. If that fails, then try booting from SPI or I<sup>2</sup>C EEPROM or Serial Flash.
4. Enter debug/monitor mode in which a command prompt is available for debugging registers, downloading code, etc.

### 4.2 Clock Generation Block

The ZL10310/ZL10311 devices use two separate external clock sources to provide all the clocks required; a 27MHz external Voltage Controlled crystal Oscillator (VCXO), and a 20.48MHz external Crystal Oscillator.

A standard 27MHz input to the systems PLL is supplied from an external VCXO. Outputs from this PLL are used to clock the various internal MPEG decoders, the PowerPC<sup>®</sup> micro controller system, and the external SDRAM. The frequency can be adjusted in the ppm range, using a voltage produced by the pulse width modulated frequency error signal, available from GPIO port GP29.

The 27MHz input also drives a separate audio PLL that is dedicated to providing 256/512 times the audio sampling rate for the audio decoder and external audio DAC.

The COFDM de-modulators have their own PLL driven from an internal 20.48MHz oscillator. An external crystal is required for this oscillator.

### 4.3 Coded Orthogonal Frequency Division Multiplex (COFDM) Demodulator

The COFDM demodulator is used to demodulate a digitized COFDM modulated IF signal from the TV Tuner, and ultimately convert the resulting MPEG-2 Transport Stream to the MPEG-2 demultiplexer.

The Digitized IF is converted to a complex Baseband signal centered on zero frequency. It also removes adjacent channel interference prior to a Time-to-Frequency Fast Fourier Transform (FFT). The resulting signals are then sent to a digital re-timing block, symbol sync, carrier recovery, and timing recovery. An AGC signal, with a variable mark space ratio, is provided to control the signal levels in the tuner sections of the receiver. Forward Error Correction (FEC) is performed by Viterbi decoding of the convolutional coded data, followed by de-interleaving, Reed-Solomon decoding, and energy dispersal de-randomising. The output is MPEG-2 Transport Stream packets, in byte format.

The COFDM demodulator is fully compliant with the ETSI 300 744 and Digital Television Group (DTG) specifications. Key features are:

- FFT processor operates in 2k and 8k carrier mode.<sup>1</sup>
- All hierarchical and non-hierarchical constellations.
- Automatic digital carrier recovery over a wide range of offsets without the need for AFC
- Automatic digital carrier recovery without the need for a VCXO
- Common phase error correction
- Channel correction using time and frequency filtering
- Automatic co - channel protection, frame sync, and fast channel re- acquisition
- Internal controller handles all tracking and acquisition
- Viterbi decoding with code rates of 1/2, 2/3, 3/4, 5/6, 6/7, and 7/8
- Automatic synchronization and code rate detection
- Constraint length K = 7
- Trace back depth of 128
- De-interleaver followed by DVB Reed Solomon error correction
- De-randomizer and common interface formatting

### 4.4 MPEG Audio Decoder

The MPEG Audio Decoder produces dual channel outputs from MPEG -1 or MPEG -2 Transport Streams with a maximum rate of 640 kbit/sec. It supports sampling rates of 32, 44.1, and 48 KHz, plus the half rate options. All sampling rates, plus 512/256 Fs, are produced from an internal PLL. A version of the device is available which produces six channels of audio output for holders of the Dolby<sup>®</sup> Digital<sup>2</sup> License.

- Decodes MPEG-1 and dual channel MPEG-2 audio
- Performs MPEG-1 audio parsing and MPEG-2 Packetised Elementary Stream (PES) audio parsing, or accepts audio elementary streams
- Supports 32kHz, 44.1 kHz, and 48 kHz sampling rates plus the half rate options
- All sampling rates, plus 512/256 Fs, derived from an internal PLL
- 64 step audio attenuation with smooth step transitions
- SPDIF output meeting IEC1937 specifications
- Re-locatable ancillary data region
- Audio Clip Mode
- Dolby<sup>®</sup> AC3 option<sup>2</sup>

---

1. For details on 8k carrier performance and use, please consult Zarlink Field Applications

2. The ZL10311 device is awaiting Dolby Certification

---

#### 4.5 MPEG-2 Video Decoder

The MPEG-2 Video Decoder provides complete decoding and synchronized playback of MPEG-2 MP@ML (Main Profile at Main Level) video streams. It supports the decoding of still pictures as well as moving video, with error concealment when necessary. A command driven local controller minimizes the amount of application software needed to control the decoding / channel change process.

The decoder accepts PES from the Transport De-multiplexer, with average rates of up to 15 Mbps. PES header parsing supports the extraction of Presentation Time Stamp (PTS) values, which are then used by the audio/ video synchronization hardware. PES or ES streams can be directly decoded from SDRAM in the Video Clip mode of operation.

Feature summary:

- Packetised MPEG-2 MP @ ML video streams from the transport demultiplexer or from SDRAM
- MPEG-1 video (ES) streams from SDRAM
- Sustained bit rates from 1.5 Mbps to 15 Mbps.
- Local processor driven by commands from the application processor
- Sophisticated error concealment based on the use of stored motion vectors from the previous row
- Supports the decoding of still images
- Automatic or manual image re-sizing
- Conversion of MPEG-1, 24 Hz progressive scan, pictures to 60 Hz interlaced (3:2 pull-down)

#### 4.6 PowerPC 405™ Processor

An integrated PowerPC 405™ processor core is provided for applications and control software, and this provides approx. 150 Drystone MIPS with a clock of 108 MHz.

It has instruction and data caches with lock down facilities such that defined areas can be used as general purpose ram. The processor has its own internal bus to which is attached the caches, all the peripherals, and a DMA controller. Code can thus be executed, using internal resources, whilst the MPEG decoders are using the SDRAM.

This processor bus is also connected to an auxiliary external bus, which is used for Flash code transfer during the power on routine, and for Flash write operations. PCMCIA, and IDE data transfers also use this bus to provide data and address signals, but their respective control signals have dedicated pins. A bridge to the internal multi-master bus provides software access to the external SDRAM.

All internal and external memory is in a unified address space, and a DMA controller supports high speed data transfers. Controllers are provided for two smart cards, an RS232 modem, a serial Codec, an I<sup>2</sup>C master, a synchronous serial port, and an IRDA interface. Individual bit I/O is also supported.

Key Features:

- PowerPC 405™ Processor Core running at 108 MHz
  - Integrated instruction and data caches (16k/16k) with lock down
  - Integrated set top box peripheral controllers
  - Four channel DMA controller for peripheral and data transfers
  - Dedicated internal processor bus with its own SDRAM controller and auxiliary bus
  - Bridge to the decoder multi-master bus and shared SDRAM
  - Real Time Counters
  - Watch dog timer
  - Interrupt Controller
-

## 4.7 Transport Engine

The ZL10310/ZL10311 devices contain a dedicated hardware implementation of an MPEG/DVB transport stream de-multiplexer, with the configuration of this hardware controlled by application software. Included in the hardware are synchronization, Packet Identifier (PID) filtering, clock recovery, de-scrambling, and table section filtering. PID filtered packets are stored in a local buffer, which can hold up to 10 packets before they are moved to the decoders or to memory queues in SDRAM. The queues are used for the tables containing system information. Packets for three destinations can be moved concurrently out of the buffer.

The hardware acts in conjunction with a Transport Assist Processor, and the resultant hardware/software combination gives increased adaptability and extended processing capability. Further parsing and filtering is possible, and interrupts can be generated to notify the processor when a given condition has been met. The transport assist processor can then read and manipulate packets whilst they are still in the transport packet buffer. It can then allow data to pass through to SDRAM or the decoders, or can record status information and optionally interrupt the application.

Key Features:

- 32 PID values can be used to filter the transport stream
- Flexible, hardware based, section filtering
- 64, 4 byte, filter blocks.
- Filter blocks can be cascaded to provide deep filtering when necessary
- Hardware Cyclical Redundancy Check (CRC) checking
- Captured data is transferred to one of thirty two queues in SDRAM
- Options to transfer complete transport packets with or without headers, or sections
- Adaptation fields can be delivered to a separate queue
- Hardware to extract PCR values with option for software filtering to remove long term jitter
- Comprehensive error detection hardware
- Integrated DVB descrambler

## 4.8 Video Display System

The Video Display System provides multi-layered video. This features the On-Screen Display (OSD) for menuing and MHEG-5, the Decoded Video Presentation system, and a Video Blending capability to merge the OSD and Video.

The On-Screen Display system is designed to meet or exceed the specifications of major European broadcasters. The final image on the screen is constructed from five separate planes using a fixed display hierarchy. The screen hierarchy consists of:

1. Cursor plane (Top)
2. Region-based graphics plane (typically used for EPG and System menus)
3. Video plane
4. Still image plane (typically used for MHEG-5)
5. Background plane

All planes, apart from the background plane, can be separately enabled. The graphics and image planes are region based, and driven by means of bitmaps controlled by a link-list processor. They can operate independently, but have nearly identical operational controls. The size of a bitmap region can vary between 4 pixels wide by 2 pixels deep, and 1K pixels wide and 1K pixels deep. The color resolution of a pixel within a region can be defined by 2, 4, 8, or 16 bits. The 16-bit option is for direct colors; the other options use color look up tables.

The Video Presentation system is used to scale and process a decoded Video signal. Decoded Video is stored in Field Stores contained in external SDRAM memory. Prior to display it can be automatically scaled from the original resolution and aspect ratio up to PAL or NTSC full screen size. If the encoded image has a 16:9 aspect ratio, but the display has a 4:3 aspect ratio, then any horizontal scaling factor necessary to fill the screen must be adjusted by

a further factor of 4/3. Alternatively, a factor of 3/4 can be applied vertically (letter box mode). Video is displayed at the standard PAL or NTSC field rates. Synchronization signals for video presentation can be provided by either the video decoder itself (master mode), or the decoder can slave to incoming signals.

The Video Blending System is used to blend the outputs from separate Digital Encoded Video (DENC) blocks for the Video and OSD systems on-chip:

1. RGB – Red Green Blue
2. Y U/V
3. CVBS – Chroma Video Blanking and Sync

### 5.0 Physical Specification

The device is contained in a 388-ball Enhanced Plastic Ball-Grid Array (388 EPBGA) package:

- Body Size: 27mm x 27mm
- Ball Count: 388 (includes 36 Thermal Balls)
- Ball Pitch: 1.0mm
- Ball Matrix: 26 x 26 (partially populated with a 6 x 6 GND matrix in the centre)
- Ball Diameter 0.60mm
- Total Package Thickness 2.65mm

Package is viewed from the top side (i.e. through top of the package). Note ball A1 is non-chamfered corner.

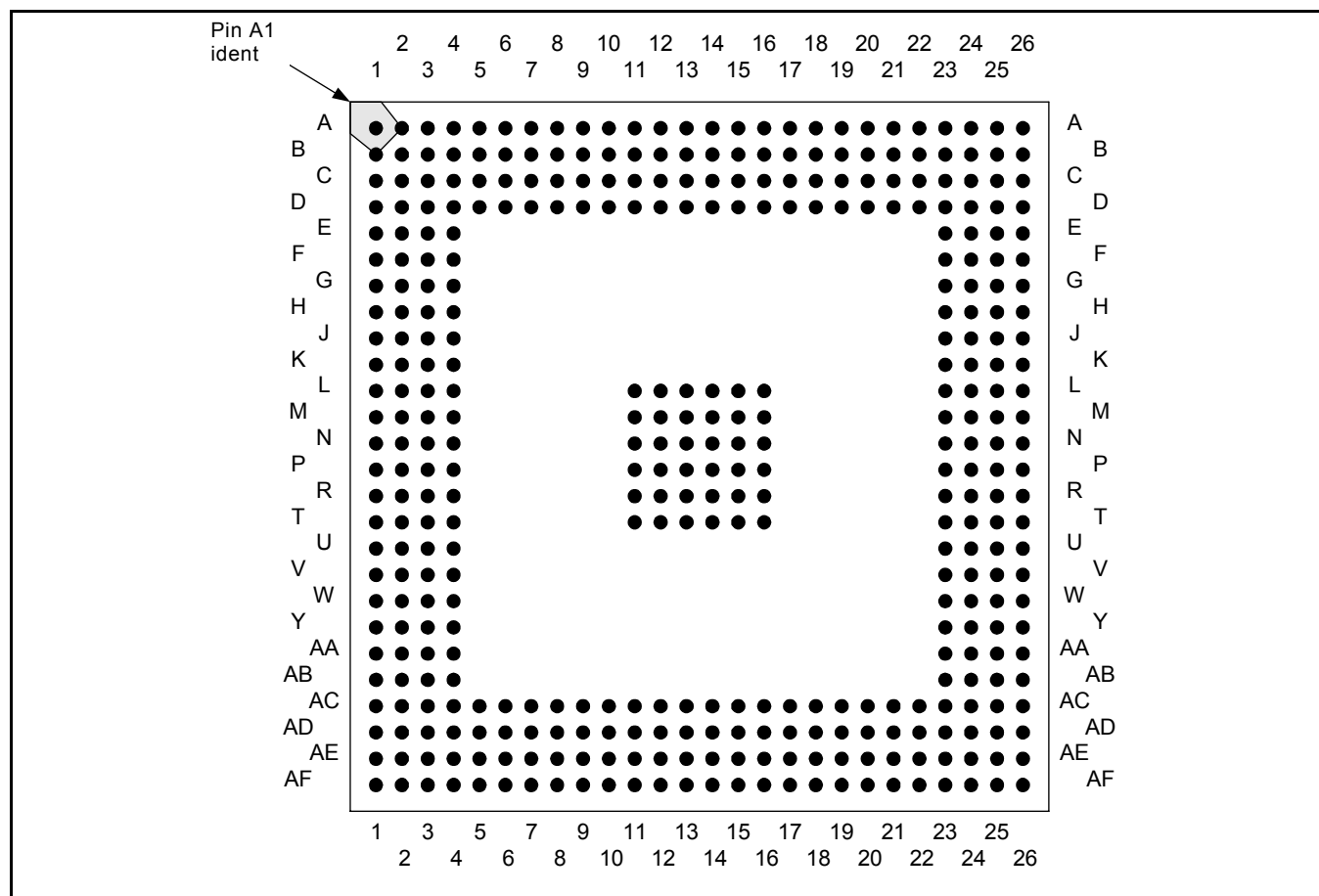

Figure 3 - Package View and Ball Positions

## 6.0 ZL10310/ZL10311 388-pin Package Pin Descriptions

This section explains the ZL10310 and ZL10311 device pin functions. The following tables are segmented by signal functions. Many of the pins listed below have multiple functions, and in these cases there is information on how the multiplexed function connects to the pin.

Many references are made to register settings throughout the Pin Descriptions. The details of the ZL10310 and ZL10311 registers can be found in the Hardware Design Manual for the ZL103xx family of Integrated Digital Television Processors (Publication DM5797), available to customers on request, subject to NDA.

### 6.1 Pin Types

- I An Input Type with no designator indicates that the signal must be produced by a device using 3.3V outputs, and ESD protection is provided. There is no internal pull up, so unused inputs should be tied high or low.
- IO Pin Type indicates that the pin can be programmed with control bits to be used as an input or an output.
- B Pin Type indicates that the pin function can alternate between an input and output depending on the use at that instant i.e. it is Bi-directional. Out characteristics are the same as an Out pin.
- OD is an open drain Output.
- O is a standard 3.3 V, 65 ohm, output, unless otherwise specified. DC drive is 8.2mA/5.4mA @ VH/VL respectively. Maximum slew rate is 75mA/ns, unless otherwise specified.
- 5V is a 5V tolerant Input or Output. An Input Type with a 5V designator indicates that the input tolerates 5V signals. There is no internal pull up.

### 6.2 Front End Interfaces

Pin Name	Pin No.	Function	Pin Type	Description	Notes
ADCCLK	R02	ADCCLK	O	Sampling Clock Output to External Tuner IF Analog to Digital Converter. Clock = 20.48MHz.	
AGC[0]	L02	Tuner AGC control	O 5V	Master AGC Control Output to External TV Tuner	1
AGC[1]	M03	Tuner AGC control offset	O 5V	Secondary AGC Control Output to External TV Tuner. Used to provide a differential AGC feed to external TV Tuner, if required.	1
GPP[0]	L01	Tuner_SCL	O 5V	External TV Tuner Control Bus - Clock Output	1, 6
GPP[1]	N04	Tuner_SDA	B 5V	External TV Tuner Control Bus - Data Input/Output.	1, 6
EXT_IN[0]	K01	ED1_MDO[7] (MSB)	I	External Demodulator 1 Digital Input - Data Bit 7 (MSB)	5, 7
		DV2_IN_DATA[7] (MSB)	I	<i>Reserved</i>	7
		RW_TDO	O	Debug Interface - JTAG TDO (Data Out)	3

Pin Name	Pin No.	Function	Pin Type	Description	Notes
EXT_IN[1]	K02	ED1_MDO[6]	I 5V	External Demodulator 1 Digital Input - Data Bit 6	1, 5, 7
		RW_TDI	I 5V	Debug Interface - JTAG TDI (Data In)	1, 3
		DA_SER_DATAI	I 5V	Digital Audio Serial Data Input. Main left and right serial audio data at a rate of 64fs. Signal routed through to GP12 (not bonded out)	1, 4
EXT_IN[2]	J01	ED1_MDO[5]	I	External Demodulator 1 Digital Input - Data Bit 5	5, 7
		DV2_IN_DATA[6]	I	<i>Reserved</i>	7
		RW_HALT	I	Debug Interface - JTAG Halt	3
EXT_IN[3]	L03	ED1_MDO[4]	I	External Demodulator 1 Digital Input - Data Bit 4	5, 7
		DV2_IN_DATA[5]	I	<i>Reserved</i>	7
		RW_TMS	I	Debug Interface - JTAG TMS	3
EXT_IN[4]	J02	ED1_MDO[3]	I	External Demodulator 1 Digital Input - Data Bit 3	5, 7
		DV2_IN_DATA[4]	I	<i>Reserved</i>	7
		RW_TCK	I	Debug Interface - JTAG TCK	3
EXT_IN[5]	L04	ED1_MDO[2]	I	External Demodulator 1 Digital Input - Data Bit 2	5, 7
		DV2_IN_DATA[3]	I	<i>Reserved</i>	7
		Test[0]	I	Test Mode A - Test Pin 0	
EXT_IN[6]	K03	ED1_MDO[1]	I	External Demodulator 1 Digital Input - Data Bit 1	5, 7
		DV2_IN_DATA[2]	I	<i>Reserved</i>	7
		Test[1]	I	Test Mode A - Test Pin 1	
EXT_IN[7]	H02	ED1_MDO[0] (LSB)	I	External Demodulator 1 Digital Input - Data Bit 0 (LSB)	5, 7
		DV2_IN_DATA[1]	I	<i>Reserved</i>	7
		Test[2]	I	Test Mode A - Test Pin 2	
EXT_IN[8]	G01	ED1_MVAL	I	External Demodulator 1 Digital Input - Data Valid Input	5
		DV2_IN_DATA[0] (LSB)	I	<i>Reserved</i>	7
		Test[3]	I	Test Mode A - Test Pin 3	
EXT_IN[9]	J03	ED1_MCLK	I	External Demodulator 1 Digital Input - Clock Input	5
		DV2_Pixel_Clk	I	<i>Reserved</i>	
		Test[4]	I	Test Mode A - Test Pin 4	

Pin Name	Pin No.	Function	Pin Type	Description	Notes
ADC_IN[0]	V03	COFDM_ADCIN[8] (MSB)	I	COFDM Digital Input from Ext. ADC - Data Bit 8 (MSB)	2, 5, 7
		DV2_IN_DATA[7] (MSB)	I	<i>Reserved</i> (when EXT_IN[0] used for JTAG in Debug)	7
		ED2_MDO[7] (MSB)	I	External Demodulator 2 Digital Input - Data Bit 7 (MSB)	7
ADC_IN[1]	W03	COFDM_ADCIN[7]	I	COFDM Digital Input from Ext. ADC - Data Bit 7	2, 5, 7
		ED2_MDO[6]	I	External Demodulator 2 Digital Input - Data Bit 6	
ADC_IN[2]	AA02	COFDM_ADCIN[6]	I	COFDM Digital Input from Ext. ADC - Data Bit 6	2, 5, 7
		DV2_IN_DATA[6]	I	<i>Reserved</i> (when EXT_IN[2] used for JTAG in Debug)	7
		ED2_MDO[5]	I	External Demodulator 2 Digital Input - Data Bit 5	7
ADC_IN[3]	AB01	COFDM_ADCIN[5]	I	COFDM Digital Input from Ext. ADC - Data Bit 5	2, 5, 7
		DV2_IN_DATA[5]	I	<i>Reserved</i> (when EXT_IN[3] used for JTAG in Debug)	7
		ED2_MDO[4]	I	External Demodulator 2 Digital Input - Data Bit 4	7
ADC_IN[4]	Y03	COFDM_ADCIN[4]	I	COFDM Digital Input from Ext. ADC - Data Bit 4	2, 5, 7
		DV2_IN_DATA[4]	I	<i>Reserved</i> (when EXT_IN[4] used for JTAG in Debug)	7
		ED2_MDO[3]	I	External Demodulator 2 Digital Input - Data Bit 3	7
ADC_IN[5]	AB02	COFDM_ADCIN[3]	I	COFDM Digital Input from Ext. ADC - Data Bit 3	2, 5, 7
		DV2_IN_DATA[3]	I	<i>Reserved</i> (when EXT_IN[5] used for JTAG in Debug)	7
		ED2_MDO[2]	I	External Demodulator 2 Digital Input - Data Bit 2	7
ADC_IN[6]	AC01	COFDM_ADCIN[2]	I	COFDM Digital Input from Ext. ADC - Data Bit 2	2, 5, 7
		DV2_IN_DATA[2]	I	<i>Reserved</i>	7
		ED2_MDO[1]	I	External Demodulator 2 Digital Input - Data Bit 1	7
ADC_IN[7]	AA04	COFDM_ADCIN[1]	I	COFDM Digital Input from Ext. ADC - Data Bit 1	2, 5, 7
		DV2_IN_DATA[1]	I	<i>Reserved</i>	7
		ED2_MDO[0] (LSB)	I	External Demodulator 2 Digital Input - Data Bit 0 (LSB)	7

Pin Name	Pin No.	Function	Pin Type	Description	Notes
ADC_IN[8]	AA03	COFDM_ADCIN[0] (LSB)	I	COFDM Digital Input from Ext. ADC - Data Bit 0 (LSB)	2, 5, 7
		DV2_IN_DATA[0] (LSB)	I	<i>Reserved</i>	7
		ED2_MOVAL	I	External Demodulator 1 Digital Input - Data Valid Input	
ADC_IN[9]	AC02	DV2_IN_Pixel_Clk	I	<i>Reserved</i>	
		ED2_MOCLK	I	External Demodulator 1 Digital Input - Clock Input	

Note 1: 5V tolerant connection to allow use of 5V Tuner devices

Note 2: Multiplex setup with COFDM Register Bit 0 = '1'

Note 3: Multiplex setup with CICSEL3 Register Bits 9:11 = '111'

Note 4: Multiplex setup with CICSEL3 Register Bit 6 = '1', and GPIS2 Register Bits 24:25 = '01'

Note 5: Multiplex setup with COFDM Register Bit 0 = '0'

Note 6: External pull-up to Tuner Vdd PSU required on GPPx lines.

Note 7: The ADC\_IN [0:9] and EXT\_IN [0:9] inputs on the Front End interface are configured as "Big Endian". This means that bit [0] is the Most Significant Bit (MSB) for the multiplexed functions mapped to that pin.

Note 8: When the ADC\_IN [0:9] and EXT\_IN [0:9] pins are used to provide various alternative inputs within one application, then each set of inputs must have a tri-state buffer. The enables for these buffers should then be controlled by general purpose I/O pins.

### 6.3 Video DAC Outputs

Pin Name	Pin No.	Pin Type	Description	Notes
DAC_OP0	AE15	O	Video Triple-DAC 1 output 1.	1, 2
DAC_OP1	AD15	O	Video Triple-DAC 1 output 2.	1, 2
DAC_OP2	AD13	O	Video Triple-DAC 1 output 3.	1, 2
DAC_OP3	AD10	O	Video Triple-DAC 2 output 1.	1, 2
DAC_OP4	AF06	O	Video Triple-DAC 2 output 2.	1, 2
DAC_OP5	AF10	O	Video Triple-DAC 2 output 3.	1, 2
DAC1_CREF_OUT	AF11	O	De-coupling for triple DAC 1 - to GND	
DAC1_GREF_OUT	AF17	O	De-coupling for triple DAC 1 - to AVDD	
DAC1_RREF_OUT	AE13	O	Gain control for triple DAC 1.	3
DAC1_VREF_IN	AE14	I	Voltage reference input (1.2V) for Video Triple-DAC 1.	4
DAC2_CREF_OUT	AE11	O	De-coupling for triple DAC 2 - to GND	
DAC2_GREF_OUT	AF05	O	De-coupling for triple DAC 2 - to AVDD	
DAC2_RREF_OUT	AE09	O	Gain control for triple DAC 2.	3
DAC2_VREF_IN	AF07	I	Voltage reference input (1.2V) for Video Triple-DAC 2	4

Note 1: Video outputs capable of driving between 37.5ohm and 75ohm loads.

Note 2: Triple DAC output can be setup using the DENCMUX register to output any of the following types of video signal:  
RGB, CVBS, Y U/V

Note 3: Gain set using Current Adjust resistor to GND. Typically need 392ohms for a DAC load of 37.5ohms.

Note 4: Apply external reference (1.2V) when internal reference is not in use.

## 6.4 SDRAM Interfaces

The ZL10310 and ZL10311 devices have 2 independent SDRAM interfaces. The main SDRAM interface is SDRAM1 which is used as the main memory space for both the PowerPC® processor and Video/Audio decoding. If required a separate processor-only SDRAM interface can be used; this is the optional SDRAM0 interface.

All the signals for the SDRAM1 and SDRAM0 interfaces are configured as “Big Endian”, which signifies that bit [0] on both the Address and Data buses is the Most Significant Bit (MSB).

Pin Name	Pin No.	Pin Type	Description	Notes
SD1_ADDR[00]	D24	O	SDRAM1 Bus - Address Bit 0 (MSB)	
SD1_ADDR[01]	F26	O	SDRAM1 Bus - Address Bit 1	
SD1_ADDR[02]	F25	O	SDRAM1 Bus - Address Bit 2	
SD1_ADDR[03]	E25	O	SDRAM1 Bus - Address Bit 3	
SD1_ADDR[04]	E26	O	SDRAM1 Bus - Address Bit 4	
SD1_ADDR[05]	D26	O	SDRAM1 Bus - Address Bit 5	
SD1_ADDR[06]	L23	O	SDRAM1 Bus - Address Bit 6	
SD1_ADDR[07]	C26	O	SDRAM1 Bus - Address Bit 7	
SD1_ADDR[08]	A25	O	SDRAM1 Bus - Address Bit 8	
SD1_ADDR[09]	B23	O	SDRAM1 Bus - Address Bit 9	
SD1_ADDR[10]	B24	O	SDRAM1 Bus - Address Bit 10	
SD1_ADDR[11]	C23	O	SDRAM1 Bus - Address Bit 11	
SD1_ADDR[12]	C25	O	SDRAM1 Bus - Address Bit 12	
SD1_ADDR[13]	D25	O	SDRAM1 Bus - Address Bit 13 (LSB)	
SD1_DATA[00]	N24	B	SDRAM1 Bus - Data Bit 0 (MSB)	
SD1_DATA[01]	N26	B	SDRAM1 Bus - Data Bit 1	
SD1_DATA[02]	M25	B	SDRAM1 Bus - Data Bit 2	
SD1_DATA[03]	T23	B	SDRAM1 Bus - Data Bit 3	
SD1_DATA[04]	L25	B	SDRAM1 Bus - Data Bit 4	
SD1_DATA[05]	K26	B	SDRAM1 Bus - Data Bit 5	
SD1_DATA[06]	K24	B	SDRAM1 Bus - Data Bit 6	
SD1_DATA[07]	J25	B	SDRAM1 Bus - Data Bit 7	
SD1_DATA[08]	J24	B	SDRAM1 Bus - Data Bit 8	

Pin Name	Pin No.	Pin Type	Description	Notes
SD1_DATA[09]	K25	B	SDRAM1 Bus - Data Bit 9	
SD1_DATA[10]	L26	B	SDRAM1 Bus - Data Bit 10	
SD1_DATA[11]	L24	B	SDRAM1 Bus - Data Bit 11	
SD1_DATA[12]	M26	B	SDRAM1 Bus - Data Bit 12	
SD1_DATA[13]	M24	B	SDRAM1 Bus - Data Bit 13	
SD1_DATA[14]	N25	B	SDRAM1 Bus - Data Bit 14	
SD1_DATA[15]	P25	B	SDRAM1 Bus - Data Bit 15 (LSB)	
SD1_DQMH	H25	O	SDRAM1 Bus - Data Bus Mask High. Active High	
SD1_DQML	J26	O	SDRAM1 Bus - Data Bus Mask Low. Active High	
nSD1_RAS	G25	O	SDRAM1 Bus - Row Address Strobe. Active Low. Also known as SDRAM 1 Command Bit 2 (MSB).	
nSD1_CAS	G24	O	SDRAM1 Bus - Column Address Strobe. Active Low. Also known as SDRAM 1 Command Bit 1.	
nSD1_WE	H24	O	SDRAM1 Bus - Write Enable. Active Low. Also known as SDRAM 1 Command Bit 0 (LSB).	
SD1_CLK	G26	O	SDRAM1 Bus - Clock Output	1
nSD1_CS0	F24	O	SDRAM1 Bus - Chip Select 0. Active Low	
SD0_ADDR[00]	AC26	O	SDRAM0 Bus. Address bit 0 (MSB)	
SD0_ADDR[01]	AC24	O	SDRAM0 Bus. Address bit 1	
SD0_ADDR[02]	AB25	O	SDRAM0 Bus. Address bit 2	
SD0_ADDR[03]	AB26	O	SDRAM0 Bus. Address bit 3	
SD0_ADDR[04]	AB24	O	SDRAM0 Bus. Address bit 4	
SD0_ADDR[05]	AA24	O	SDRAM0 Bus. Address bit 5	
SD0_ADDR[06]	AA25	O	SDRAM0 Bus. Address bit 6	
SD0_ADDR[07]	Y26	O	SDRAM0 Bus. Address bit 7	
SD0_ADDR[08]	Y25	O	SDRAM0 Bus. Address bit 8	
SD0_ADDR[09]	V24	O	SDRAM0 Bus. Address bit 9	
SD0_ADDR[10]	W24	O	SDRAM0 Bus. Address bit 10	
SD0_ADDR[11]	Y24	O	SDRAM0 Bus. Address bit 11	
SD0_ADDR[12]	AA26	O	SDRAM0 Bus. Address bit 12	
SD0_ADDR[13]	AA23	O	SDRAM0 Bus. Address bit 13 (LSB)	
SD0_DATA[00]	AE18	B	SDRAM0 Bus - Data Bit 0 (MSB)	

Pin Name	Pin No.	Pin Type	Description	Notes
SD0_DATA[01]	AD19	B	SDRAM0 Bus - Data Bit 1	
SD0_DATA[02]	AD20	B	SDRAM0 Bus - Data Bit 2	
SD0_DATA[03]	AF20	B	SDRAM0 Bus - Data Bit 3	
SD0_DATA[04]	AD21	B	SDRAM0 Bus - Data Bit 4	
SD0_DATA[05]	AE21	B	SDRAM0 Bus - Data Bit 5	
SD0_DATA[06]	AE22	B	SDRAM0 Bus - Data Bit 6	
SD0_DATA[07]	AF23	B	SDRAM0 Bus - Data Bit 7	
SD0_DATA[08]	AD23	B	SDRAM0 Bus - Data Bit 8	
SD0_DATA[09]	AD22	B	SDRAM0 Bus - Data Bit 9	
SD0_DATA[10]	AF22	B	SDRAM0 Bus - Data Bit 10	
SD0_DATA[11]	AF21	B	SDRAM0 Bus - Data Bit 11	
SD0_DATA[12]	AC21	B	SDRAM0 Bus - Data Bit 12	
SD0_DATA[13]	AE20	B	SDRAM0 Bus - Data Bit 13	
SD0_DATA[14]	AE19	B	SDRAM0 Bus - Data Bit 14	
SD0_DATA[15]	AF18	B	SDRAM0 Bus - Data Bit 15 (LSB)	
SD0_DQMH	AE24	O	SDRAM0 Bus - Data Bus Mask High. Active High	
SD0_DQML	AD18	O	SDRAM0 Bus - Data Bus Mask Low. Active High	
nSD0_RAS	AD25	O	SDRAM0 Bus - Row Address Strobe. Active Low. <i>Also known as SDRAM0 Command Bit 2 (MSB).</i>	
nSD0_CAS	AF24	O	SDRAM0 Bus - Column Address Strobe. Active Low. <i>Also known as SDRAM0 Command Bit 1.</i>	
nSD0_WE	AE23	O	SDRAM0 Bus - Write Enable. Active Low. <i>Also known as SDRAM0 Command Bit 0 (LSB).</i>	
SD0_CLK	AE26	O	SDRAM0 Bus - Clock Output	1
nSD0_CS0	AD26	O	SDRAM0 Bus - Chip Select 0. Active Low	

Note 1: SD0\_CLK / SD1\_CLK output is 50ohm impedance with 130ma/ns slew rate

## 6.5 Bit Stream Interfaces

The ZL10310 and ZL10311 devices have a fully DVB-compatible byte-wide Common Interface, which is a bitstream data Input/Output bus. There are multiplexed functions on these pins, and included is information on how to access these multiplexed signals. The multiplexed functions include access to Address/Data Bits of the Auxiliary External Bus (configured on this interface to access PCMCIA (PC) Cards), RISC Trace debug ports, Simplified GPIO Bus 1 and Smart Card Interface 1.

The Data pins for Output (MOD[0:7]) and Input (MID[0:7]) are configured as “Big Endian”. This means that bit [0] is the Most Significant Bit (MSB) for the Common Interface and Auxiliary Bus signals.

The provision of options, and the avoidance of the need for external pull ups, precludes the use of 5 volt tolerant inputs. The use of a 5-volt smart card would thus require external level translators.

Pin Name	Pin No.	Function	Pin Type	Description	Notes
MOD[0]	T02	CIO_MOD[0] (MSB)	O	Common Interface Output - Data Bit 0 [MSB]	1
		RESET_4	O	Bit 4 output from RESET Register. <i>Also mapped to PCMCIA interface Address Bit 25.</i>	2
MOD[1]	R01	CIO_MOD[1]	O	Common Interface Output - Data Bit 1	1
		RESET_3	O	Bit 3 output from RESET Register. <i>(PCMCIA Address 24)</i>	2
MOD[2]	P03	CIO_MOD[2]	O	Common Interface Output - Data Bit 2	1
		BI_ADDR_8	O	Auxiliary External Bus - Address Bit 8 <i>(PCMCIA Address 23)</i>	2
		RT_CLK	O	RISC Trace Port Clock Output	3
MOD[3]	P02	CIO_MOD[3]	O	Common Interface Output - Data Bit 3	1
		BI_ADDR_9	O	Auxiliary External Bus - Address Bit 9 <i>(PCMCIA Address 22)</i>	2
		RT_TS6 / RT_DATA[7]	O	RISC Trace Port 6 (Debug) / RISC Trace Data Bit 7 (Debug)	3
MOD[4]	P01	CIO_MOD[4]	O	Common Interface Output - Data Bit 4	1
		BI_ADDR_10	O	Auxiliary External Bus - Address Bit 10 <i>(PCMCIA Address 21)</i>	2
		RT_TS5 / RT_DATA[6]	O	RISC Trace Port 5 (Debug) / RISC Trace Data Bit 6 (Debug)	3
MOD[5]	N02	CIO_MOD[5]	O	Common Interface Output - Data Bit 5	1
		BI_ADDR_11	O	Auxiliary External Bus - Address Bit 11 <i>(PCMCIA Address 20)</i>	2
		RT_TS4 / RT_DATA[5]	O	RISC Trace Port 4 (Debug) / RISC Trace Data Bit 5 (Debug)	3
MOD[6]	M01	CIO_MOD[6]	O	Common Interface Output - Data Bit 6	1
		SGPIO1_4	IO	Simplified General Purpose Input / Output Bus 1 - Bit 4	4
		SC1_VCC_CMND	O	Smart Card 1 Interface - Vcc Enable Output	5
		BI_ADDR_12	O	Auxiliary External Bus - Address Bit 12 <i>(PCMCIA Address 19)</i>	2
		RT_TS3 / RT_DATA[4]	O	RISC Trace Port 3 (Debug) / RISC Trace Data Bit 4 (Debug)	3

Pin Name	Pin No.	Function	Pin Type	Description	Notes
MOD[7]	M02	CIO_MOD[7]	O	Common Interface Output - Data Bit 7 (LSB)	1
		SGPIO1_0	IO	Simplified General Purpose Input / Output Bus 1 - Bit 0	4
		SC1_IO	B	Smart Card 1 Interface - Data I/O	5
		BI_ADDR_13	O	Auxiliary External Bus - Address Bit 13 (PCMCIA Address 18)	2
		RT_TS20 / RT_DATA[3]	O	RISC Trace Port 20 (Debug) / RISC Trace Data Bit 3 (Debug)	3
MOVAL	T01	CIO_MVAL	O	Common Interface Output - Data Valid Indicator. <i>Data Valid for the Current Clock Cycle for Transmission.</i>	1
		SGPIO1_2	IO	Simplified General Purpose Input / Output Bus 1 - Bit 2	4
		SC1_DETECT	I	Smart Card 1 Interface - Detect Input	5
		BI_ADDR_15	O	Auxiliary External Bus - Address Bit 15 (PCMCIA Address 16)	2
		RT_TS10 / RT_DATA[2]	O	RISC Trace Port 10 (Debug) / RISC Trace Data Bit 2 (Debug)	3
MOSTRT	R03	CIO_MSTRT	O	Common Interface Output - Packet Start Indicator. <i>Identifies the first byte in a transport packet of 188 bytes.</i>	1
		SGPIO1_3	IO	Simplified General Purpose Input / Output Bus 1 - Bit 3	4
		SC1_RESET	O	Smart Card 1 Interface - Reset Output	5
		BI_ADDR_14	O	Auxiliary External Bus - Address Bit 14 (PCMCIA Address 17)	2
		RT_TS2E / RT_DATA[1]	O	RISC Trace Port 2E (Debug) / RISC Trace Data Bit 1 (Debug)	3
MOCLK	N03	CIO_MCLK	O	Common Interface Output - Bitstream Clock.	1
		SGPIO1_1	IO	Simplified General Purpose Input / Output Bus 1 - Bit 1	4
		SC1_CLK	O	Smart Card 1 Interface - Clock Output	5
		BI_ADDR_16	O	Auxiliary External Bus - Address Bit 16 (PCMCIA Address 15)	2
		RT_TS1E / RT_DATA[0]	O	RISC Trace Port 1E (Debug) / RISC Trace Data Bit 0 (Debug)	3

Pin Name	Pin No.	Function	Pin Type	Description	Notes
MID[0]	Y02	CII_MDATA[0] (MSB)	I	Common Interface Input - Bit 0 (MSB)	1, 6
		BI_DATA[0] (MSB)	I	Auxiliary External Bus - Data Bit 0 (MSB) (PCMCIA Data 15)	2, 6
MID[1]	Y01	CII_MDATA[1]	I	Common Interface Input - Bit 1	1, 6
		BI_DATA[1]	I	Auxiliary External Bus - Data Bit 1 (PCMCIA Data 14)	2, 6
MID[2]	T04	CII_MDATA[2]	I	Common Interface Input - Bit 2	1, 6
		BI_DATA[2]	I	Auxiliary External Bus - Data Bit 2 (PCMCIA Data 13)	2, 6
MID[3]	U03	CII_MDATA[3]	I	Common Interface Input - Bit 3	1, 6
		BI_DATA[3]	I	Auxiliary External Bus - Data Bit 3 (PCMCIA Data 12)	2, 6
MID[4]	V01	CII_MDATA[4]	I	Common Interface Input - Bit 4	1, 6
		BI_DATA[4]	I	Auxiliary External Bus - Data Bit 4 (PCMCIA Data 11)	2, 6
MID[5]	V02	CII_MDATA[5]	I	Common Interface Input - Bit 5	1, 6
		BI_DATA[5]	I	Auxiliary External Bus - Data Bit 5 (PCMCIA Data 10)	2, 6
MID[6]	U01	CII_MDATA[6]	I	Common Interface Input - Bit 6	1, 6
		BI_DATA[6]	I	Auxiliary External Bus - Data Bit 6 (PCMCIA Data 9)	2, 6
MID[7]	T03	CII_MDATA[7] (LSB)	I	Common Interface Input - Bit 7 (LSB)	1, 6
		BI_DATA[7] (LSB)	I	Auxiliary External Bus - Data Bit 7 (LSB) (PCMCIA Data 8)	2, 6
MISTR	U02	CII_MSTR	I	Common Interface Input - Packet Start Indicator. <i>Identifies the first byte in a transport packet of 188 bytes.</i>	
MICLK	W02	CII_MCLK	I	Common Interface Input - Bitstream Clock.	
MIVAL	AA01	CII_MVAL	I	Common Interface Input - Data Valid Indicator. <i>Data Valid for the Current Clock Cycle for Transmission.</i>	

Note 1: Multiplex setup with PORTMUX Register Bits [11:10] = '00'

Note 2: Multiplex setup with PORTMUX Register Bits [11:10] = '10'

Note 3: Multiplex setup with PORTMUX Register Bits [11:10] = '11'

Note 4: Multiplex setup with PORTMUX Register Bits [11:10] = '01' & CICSEL3 Register Bit 2 = '0'. Also if BI\_DATA[7] = '0' at Reset.

Note 5: Multiplex setup with PORTMUX Register Bits [11:10] = '01' & CICSEL3 Register Bit 2 = '1'. Also if BI\_DATA[7] = '1' at Reset.

Note 6: Data Inputs MID [0:7] should be connected to GND or Vdd if NOT required.

## 6.6 Auxiliary External Bus

The ZL1031 and ZL10311 devices have an Auxiliary External Bus, which can be configured as an IDE interface to external Hard-Disk Drives and other ATAPI devices. The Auxiliary Bus can also offer a standard interface to external memory chips, such as Flash ROM etc. There are multiplexed functions on these pins, and included is information on how to access these multiplexed signals. The multiplexed functions include access to the DVB Common Interface Address Bus.

The Data and Address pins for the Auxiliary External Bus are configured as “Big Endian”. This means that Data bit [0] and Address Bit [9] are the Most Significant Bits (MSB).

Pin Name	Pin No.	Function	Pin Type	Description	Notes
BI_ADDR[09]	A05	BI_ADDR[09] (MSB)	O	Auxiliary External Bus - Address Bit 9 (MSB)	1
		nBI_CS5	O	Auxiliary External Bus - Chip Select 5. Active Low.	2
BI_ADDR[10]	A13	BI_ADDR[10]	O	Auxiliary External Bus - Address Bit 10	
BI_ADDR[11]	A15	BI_ADDR[11]	O	Auxiliary External Bus - Address Bit 11	
BI_ADDR[12]	C14	BI_ADDR[12]	O	Auxiliary External Bus - Address Bit 12	
BI_ADDR[13]	D14	BI_ADDR[13]	O	Auxiliary External Bus - Address Bit 13	
BI_ADDR[14]	B16	BI_ADDR[14]	O	Auxiliary External Bus - Address Bit 14	3
		nIDE_iowr	O	IDE IO write signal. Active Low.	4
		nDVB_CI_iowr	O	DVB Common Interface IO write signal	5
BI_ADDR[15]	A17	BI_ADDR[15]	O	Auxiliary External Bus - Address Bit 15	3
		nIDE_iord	O	IDE IO read signal. Active Low.	4
		nDVB_CI_iord	O	DVB Common Interface IO read signal	5
BI_ADDR[16]	B17	BI_ADDR[16]	O	Auxiliary External Bus - Address Bit 16	
BI_ADDR[17]	A18	BI_ADDR[17]	O	Auxiliary External Bus - Address Bit 17	6
		DVB_CI_A[14] (MSB)	O	DVB Common Interface Address Bit 14 (MSB)	5
BI_ADDR[18]	C16	BI_ADDR[18]	O	Auxiliary External Bus - Address Bit 18	6
		DVB_CI_A[13]	O	DVB Common Interface Address Bit 13	5
BI_ADDR[19]	B18	BI_ADDR[19]	O	Auxiliary External Bus - Address Bit 19	6
		DVB_CI_A[12]	O	DVB Common Interface Address Bit 12	5
BI_ADDR[20]	D16	BI_ADDR[20]	O	Auxiliary External Bus - Address Bit 20	6
		DVB_CI_A[11]	O	DVB Common Interface - Address Bit 11	5
BI_ADDR[21]	C17	BI_ADDR[21]	O	Auxiliary External Bus - Address Bit 21	6
		DVB_CI_A[10]	O	DVB Common Interface - Address Bit 10	5

Pin Name	Pin No.	Function	Pin Type	Description	Notes
BI_ADDR[22]	B19	BI_ADDR[22]	O	Auxiliary External Bus - Address Bit 22	6
		DVB_CI_A[9]	O	DVB Common Interface - Address Bit 9	5
BI_ADDR[23]	A21	BI_ADDR[23]	O	Auxiliary External Bus - Address Bit 23	6
		DVB_CI_A[8]	O	DVB Common Interface - Address Bit 8	5
BI_ADDR[24]	C19	BI_ADDR[24]	O	Auxiliary External Bus - Address Bit 24	6
		DVB_CI_A[7]	O	DVB Common Interface - Address Bit 7	5
BI_ADDR[25]	C20	BI_ADDR[25]	O	Auxiliary External Bus - Address Bit 25	6
		DVB_CI_A[6]	O	DVB Common Interface - Address Bit 6	5
BI_ADDR[26]	B21	BI_ADDR[26]	O	Auxiliary External Bus - Address Bit 26	6
		DVB_CI_A[5]	O	DVB Common Interface - Address Bit 5	5
BI_ADDR[27]	C21	BI_ADDR[27]	O	Auxiliary External Bus - Address Bit 27	6
		DVB_CI_A[4]	O	DVB Common Interface - Address Bit 4	5
BI_ADDR[28]	B22	BI_ADDR[28]	O	Auxiliary External Bus - Address Bit 28	6
		DVB_CI_A[3]	O	DVB Common Interface - Address Bit 3	5
BI_ADDR[29]	A23	BI_ADDR[29]	O	Auxiliary External Bus - Address Bit 29	6
		DVB_CI_A[2]	O	DVB Common Interface - Address Bit 2	5
BI_ADDR[30]	C22	BI_ADDR[30]	O	Auxiliary External Bus - Address Bit 30	6
		DVB_CI_A[1]	O	DVB Common Interface - Address Bit 1	5
BI_ADDR[31]	A24	BI_ADDR[31] (LSB) / BI_WBE1	O	Auxiliary External Bus - Address Bit 31 (LSB) / Write Byte Enable Bit 1	6
		DVB_CI_A[0] (LSB)	O	DVB Common Interface Address Bit 0 (LSB)	5
BI_DATA[00]	G02	BI_DATA[00] (MSB)	O	Auxiliary External Bus - Data Bit 0 (MSB)	
BI_DATA[01]	F01	BI_DATA[01]	O	Auxiliary External Bus - Data Bit 1	
BI_DATA[02]	H03	BI_DATA[02]	O	Auxiliary External Bus - Data Bit 2	
BI_DATA[03]	G03	BI_DATA[03]	O	Auxiliary External Bus - Data Bit 3	
BI_DATA[04]	F02	BI_DATA[04]	O	Auxiliary External Bus - Data Bit 4	
BI_DATA[05]	E01	BI_DATA[05]	O	Auxiliary External Bus - Data Bit 5	
BI_DATA[06]	F03	BI_DATA[06]	O	Auxiliary External Bus - Data Bit 6	
BI_DATA[07]	E02	BI_DATA[07]	O	Auxiliary External Bus - Data Bit 7	
BI_DATA[08]	D01	BI_DATA[08]	O	Auxiliary External Bus - Data Bit 8	

Pin Name	Pin No.	Function	Pin Type	Description	Notes
BI_DATA[09]	F04	BI_DATA[09]	O	Auxiliary External Bus - Data Bit 9	
BI_DATA[10]	E03	BI_DATA[10]	O	Auxiliary External Bus - Data Bit 10	
BI_DATA[11]	D02	BI_DATA[11]	O	Auxiliary External Bus - Data Bit 11	
BI_DATA[12]	C01	BI_DATA[12]	O	Auxiliary External Bus - Data Bit 12	
BI_DATA[13]	B01	BI_DATA[13]	O	Auxiliary External Bus - Data Bit 13	
BI_DATA[14]	C02	BI_DATA[14]	O	Auxiliary External Bus - Data Bit 14	
BI_DATA[15]	D03	BI_DATA[15] (LSB)	O	Auxiliary External Bus - Data Bit 15 (LSB)	
nBI_CS0	B13	nBI_CS0	O	Auxiliary External Bus - Chip Select 0. Active Low. <i>Disabled if Internal Boot ROM enabled.</i> Used for Flash ROM.	
nBI_CS1	C13	nBI_CS1	O	Auxiliary External Bus - Chip Select 1. Active Low.	6
		nDVB_CI_Card_Enable	O	DVB Common Interface - Card Enable. Active Low.	5
nBI_CS2	A12	nBI_CS2	O	Auxiliary External Bus - Chip Select 2. Active Low.	8
		nIDE_CS0		IDE Bus Chip select 0. Active Low.	9
nBI_CS3	B11	nBI_CS3	O	Auxiliary External Bus - Chip Select 3. Active Low.	8
		nIDE_CS1	O	IDE Bus Chip select 1. Active Low.	9
nBI_OE	C11	nBI_OE	O	Auxiliary External Bus - Output Enable for ALL Aux. bus devices (including Common Interface). Active Low.	6
		DVB_CI_oe	O	DVB Common Interface - Output Enable. Active Low.	5
BI_READY	C04	BI_READY	I 5V	Auxiliary External Bus - Data Ready Input. Optional transfer complete signal from an external device.	6
		DVB_CI_wait	O 5V	DVB Common Interface - Wait.	5
BI_RnW	B07	BI_RnW	O	Auxiliary External Bus - Read/NOT Write Output.	
nBI_WBE0	B12	nBI_WBE0	O	Auxiliary External Bus - Write Byte Enable 0. Active Low.	6
		DVB_CI_we	O	DVB Common Interface - Write-enable Output.	5

Pin Name	Pin No.	Function	Pin Type	Description	Notes
nEDMAC3_ACK	B06	nEDMAC3_ACK	O	External DMA Port 3 Acknowledge Output for an IDE controller. Active Low.	
		nIDE_DMA_ACK	O	IDE Acknowledge Output. Active Low.	
nEDMAC3_REQ	A06	nEDMAC3_REQ	I	External DMA Port 3 Request Input from an IDE Controller. Active Low.	
		nIDE_DMA_REQ	I	IDE DMA Request Input. Active High.	
nIDE_OE	AD16	nIDE_OE	O	IDE Output Enable signal for a bus transceiver in the IDE data path. Active Low.	
INT2	E24	INT2	I	PowerPC® External Interrupt #2 Input. <i>Connect to VDD_IO or ground if not required.</i>	

Note 1: Multiplex setup with PORTMUX Register Bit [7] = '0'

Note 2: Multiplex setup with PORTMUX Register Bit [7] = '1'

Note 3: Multiplex setup with CIC Control Register Bit 3 = '1', & Bit 30 or Bit 31 = '0'

Note 4: Multiplex setup with CIC Control Register Bit 3 = '1', & Bit 30 or Bit 31 = '1'

Note 5: Multiplex setup with CIC Control Register Bit 3 = '0'

Note 6: Multiplex setup with CIC Control Register Bit 3 = '1'

## 6.7 Peripheral Port

The Peripheral Port is provided with 10 pins that can be configured as general purpose I/O bits, or can provide several alternative interfaces. The bit I/Os are provided by the GPIS (input) and GPOS (output) registers, along with the PORTMUX and CIC Control Register bits, and only the bits listed below should be used.

There are multiplexed functions on these pins, and included is information on how to access these multiplexed signals. The multiplexed functions include access to GPIO signals, DMA control signals, Infrared Port, Serial Communications port, S/PDIF Audio bitstream output and some ancillary Common Interface Video control signals.

Pin Name	Pin No.	Function	Pin Type	Description	Multiplex Configuration
PP[0]	C12	GPIO_22	IO	General Purpose Input/Output - Bit 22	PORTMUX Reg. Bit 8 = '0', GPOS Reg Bits 44:45 = '00'
		INT9	I	PowerPC® External Interrupt #9 Input	PORTMUX Reg Bit 8 = '0', GPIS3 Reg Bits 44:45 = '01'
		EDMAC2_ACK	O	DMA Channel 2 External Acknowledge Output	PORTMUX Reg Bit 8 = '1', CIC Control Reg bits 26:27 = '10'
		EBM_HOLDACK	IO	External Bus Master (master/slave bus arbitration controls) - Hold Acknowledge flag	PORTMUX Reg Bit 8 = '1', CIC Control Reg bits 26:27 = '11'

Pin Name	Pin No.	Function	Pin Type	Description	Multiplex Configuration
PP[1]	F23	GPIO_04	IO	General Purpose Input/Output - Bit 4	PORTMUX Reg Bit 8 = '0', GPOS Reg bits 8:9 = '00'
		nSD1_CS1	O	SDRAM1 Bus - Chip Select 1. Active Low	PORTMUX Reg Bit 8 = '0', GPOS Reg bits 8:9 = '10'
		nEDMAC2_REQ	I	DMA Channel 2 External Request Input. Active Low.	PORTMUX Reg Bit 8 = '1', CIC Control Reg bits 26:27 = '10'
		EBM_HOLDREQ	IO	External Bus Master (master/slave bus arbitration controls) - Hold Request flag	PORTMUX Reg Bit 8 = '1', CIC Control Reg bits 26:27 = '11'
PP[2]	AE05	GPIO_24	IO	General Purpose Input/Output - Bit 24	PORTMUX Reg Bit 3 = '0'
		SERIAL1/ INFRARED_RXD	I	Serial Port 1 / iRDA port Receive data	PORTMUX Reg Bit 3 = '1'
PP[3]	AC16	GPIO_25	IO	General Purpose Input/Output - Bit 25	PORTMUX Reg Bit 3 = '0'
		SERIAL1/ INFRARED_TXD	O	Serial Port 1 / iRDA port Transmit data	PORTMUX Reg Bit 3 = '1'
PP[4]	AD17	GPIO_08	IO	General Purpose Input/Output - Bit 8	PORTMUX Reg Bit 13 = '0', GPOS Reg Bits 16:17 = '00'
		SCP_CLK	O	Serial Communications Port - Baud-rate Clock output	PORTMUX Reg Bit 13 = '0', GPOS & GPIS1 Reg Bits 16:17 = '01'
		SYSCLK	O	System Clock output (54MHz)	PORTMUX Reg Bit 13 = '1'
PP[5]	AD09	GPIO_07	IO	General Purpose Input/Output - Bit 7	PORTMUX Reg Bit 2 = '0', GPOS Reg Bits 14:15 = '00'
		SCP_RXD	I	Serial Communications Port - Receive Data Input	PORTMUX Reg Bit 2 = '0', GPIS1 Reg Bits 14:15 = '01'
		EDMAC2_EOT	IO	DMA Channel 2 External End Of Transfer	PORTMUX Reg Bit 2 = '1', CIC Control Reg bits 26:27 = '10'
		EBM_BUSREQ	IO	External Bus Master - Bus Request flag (master/slave bus arbitration controls)	PORTMUX Reg Bit 2 = '1', CIC Control Reg bits 26:27 = '11'

Pin Name	Pin No.	Function	Pin Type	Description	Multiplex Configuration
PP[6]	AF02	GPIO_06	IO	General Purpose Input/Output - Bit 6	PORTMUX Reg Bit 2 = '0', GPOS Reg Bits 12:13 = '00'
		SCP_TXD	O	Serial Communications Port - Transmit Data Output	PORTMUX Reg Bit 2 = '0', GPOS Reg Bits 12:13 = '01'
		CI_PACKET_START	I	DVB Common Interface - Transport Packet Start indicator.	PORTMUX Reg Bit 2 = '0', GPIS2 Reg Bits 12:13 = '01'
		INT3	B	PowerPC® External Interrupt #3 Input	PORTMUX Reg Bit 2 = '1'
PP[7]	AE10	GPIO_18	IO	General Purpose Input/Output - Bit 18	PORTMUX Reg Bit 4 = '0', GPOS Reg Bits 36:37 = '00'
		DV_TRANSPARENCY_GATE	IO	<i>Reserved</i>	PORTMUX Reg Bit 4 = '0', GPOS & GPIS1 Reg Bits 36:37 = '01'
		SERIAL1 /INFRARED_CLK	I	Serial Port 1 / iRDA port Clock Input	PORTMUX Reg Bit 4 = '0', GPIS3 Reg Bits 36:37 = '01'
		SERIAL1 /INFRARED_nCTS	I	Serial Port 1 / iRDA port Clear-To-Send Input. Active Low.	PORTMUX Reg Bit 4 = '1'. Over-ruled when PORTMUX Reg bits 6:5 = '10' to select the SERIAL1 CTS input on MCP[1].
PP[8]	C09	GPIO_21	IO	General Purpose Input/Output - Bit 21	PORTMUX Reg Bit 0 = '0', GPOS Reg Bit 42:43 = '00'
		INT8	I	PowerPC® External Interrupt #8 Input	PORTMUX Reg Bit 0 = '0', GPIS3 Reg Bit 42:43 = '01'
		DA_IEC958	O	Digital Audio S/PDIF (IEC 958) Serial Data Output	PORTMUX Reg Bit 0 = '1'
PP[9]	AC25	GPIO_05	IO	General Purpose Input/Output - Bit 5	PORTMUX Reg Bit 1 = '0', GPOS Reg bits 10:11 = '00'
		nSD0_CS1	O	SDRAM0 Bus - Chip Select 1. Active Low	PORTMUX Reg Bit 1 = '0', GPOS Reg bits 10:11 = '10'
		DV1_PIXEL_CLOCK	O	<i>Reserved</i>	PORTMUX Reg Bit 1 = '1'

Note 1: DV\_TRANSPARENCY\_GATE Output controlled by the OSD bitmap; used to control the drivers of another pixel bus. Programmable polarity.

## 6.8 Modem/Codec Interface

This interface allows a full 16550-compatible UART interface, a standard serial Port for iRDA, and a Synchronous RS232-compatible Modem interface. There is also provision for 4 GPIO ports.

When MCP7:4 provide a 4-wire Codec interface, MCP3:0 would normally be used to provide four more general purpose I/O bits but can alternatively supply additional Serial 1 flags. When a full RS232 Modem interface is required, the complete MCP interface must be used for Serial 0 signals.

The software options provided allow a full interface to an external Modem, using the Serial 0 interface, whilst still leaving a basic Serial 1 interface on the Peripheral Port (see section 6 above, in the Pin Descriptions section).

Pin Name	Pin No.	Function	Pin Type	Description	Notes
MCP[0]	T24	SERIAL0/16550_RI	I	Serial Port 0 / 16550 UART Ring Indicator Input	1
		SERIAL1/INFRARED_RTS	O	Serial Port 1 / iRDA port Request-To-Send Output	2
		GPIO_28	IO	General Purpose Input/Output - Bit 28	3
MCP[1]	V25	SERIAL0/16550_DCD	I	Serial Port 0 / 16550 UART Data Carrier Detect Input	1
		nSERIAL1/INFRARED_CTS	I	Serial Port 1 / iRDA port Clear-To-Send Input. Active Low.	2
		GPIO_27	IO	General Purpose Input/Output - Bit 27	3
MCP[2]	P23	SERIAL0/16550_DTR	O	Serial Port 0 / 16550 UART Data Terminal Ready Output	1
		SERIAL1/INFRARED_DTR	O	Serial Port 1 / iRDA port Data Terminal Ready Output	2
		GPIO_26	IO	General Purpose Input/Output - Bit 26	3
MCP[3]	U26	SERIAL0/16550_DSR	I	Serial Port 0 / 16550 UART Data Set Ready Input	1
		SERIAL1/INFRARED_DSR	I	Serial Port 1 / iRDA port Data Set Ready Input	2
		GPIO_23	IO	General Purpose Input/Output - Bit 23	3
MCP[4]	T26	SERIAL0/16550_TXD	O	Serial Port 0 / 16550 UART Transmit Data Output	4
		SSP_TXD	O	Synchronous Serial Port for Modem - Transmit Data Output	5
MCP[5]	U25	SERIAL0/16550_RXD	I 5V	Serial Port 0 / 16550 UART Receive Data Input	4
		SSP_RXD	I 5V	Synchronous Serial Port for Modem - Received Data Input	5
MCP[6]	V26	nSERIAL0/16550_CTS	I 5V	Serial Port 0 / 16550 UART Clear-To-Send Input. Active Low.	4
		SSP_CLK	I 5V	Synchronous Serial Port for Modem - Baud Rate Clock	5
MCP[7]	P24	nSERIAL0/16550_RTS	O 5V	Serial Port 0 / 16550 UART Request-To-Send Output.	4
		SSP_FS	IO 5V	Synchronous Serial Port for Modem - Frame Sync	5

Note 1: Multiplex setup with PORTMUX Register Bits [6:5] = '11'

Note 2: Multiplex setup with PORTMUX Register Bits [6:5] = '10'

Note 3: Multiplex setup with PORTMUX Register Bits [6:5] = '0x'

Note 4: Multiplex setup with CIC Control Register Bit 2 = '0' and Bit 28 = '1'

Note 5: Multiplex setup with CIC Control Register Bits 2 = '1', Bit 28 = '1' and CICSEL3 Register Bit 6 = '0'

## 6.9 Smart Card Interface

Pin Name	Pin No.	Function	Pin Type	Description	Notes
SGPIO0[0]	AD05	SGPIO0_0	IO 5V	Simplified General Purpose Input / Output Bus 0 - Bit 0	1
		SC0_IO	B 5V	Smart Card 0 Interface - Data I/O	2
SGPIO0[1]	AC03	SGPIO0_1	IO 5V	Simplified General Purpose Input / Output Bus 0 - Bit 1	1
		SC0_CLK	O 5V	Smart Card 0 Interface - Clock Output	2
SGPIO0[2]	AF04	SGPIO0_2	IO 5V	Simplified General Purpose Input / Output Bus 0 - Bit 2	1
		SC0_DETECT	I 5V	Smart Card 0 Interface - Detect Input	2
SGPIO0[3]	AD06	SGPIO0_3	IO 5V	Simplified General Purpose Input / Output Bus 0 - Bit 3	1
		SC0_RESET	O 5V	Smart Card 0 Interface - Reset Output	2
SGPIO0[4]	AF03	SGPIO0_4	IO 5V	Simplified General Purpose Input / Output Bus 0 - Bit 4	1
		SC0_VCC_COMMAND	O 5V	Smart Card 0 Interface - Vcc Enable Output	2

Note 1: Multiplex setup with CICSEL3 Register Bit 1 = '0'. Also if BI\_DATA[6] = '0' at Reset.

Note 2: Multiplex setup with CICSEL3 Register Bit 1 = '1'. Also if BI\_DATA[6] = '1' at Reset.

## 6.10 General Purpose Input Output Interfaces

The General Purpose Input Output Interface is provided with 10 pins that can be configured as general purpose I/O bits, or can provide several alternative interfaces. The bit I/Os are provided by the GPIS (input) and GPOS (output) registers, and only the bits listed below should be used. Care should be observed when programming the registers allocated to each of the GPIO ports.

There are multiplexed functions on these pins, and included is information on how to access these multiplexed signals. The multiplexed functions include access to GPIO signals, I<sup>2</sup>C bus, I<sup>2</sup>S Audio Output signals, Test interface signals, Clock signals, Video Sync Signals, Synchronous Serial Port signals and a VCXO error signal.

Pin Name	Pin No.	Function	Pin Type	Description	Multiplex Configuration
GP00	AF16	GPIO_00	IO	General Purpose Input/Output - Bit 0	GPOS Reg Bits 0:1 = '00'
		I2C1_SCL	B	I <sup>2</sup> C (Inter Integrated Circuit) Bus 1 Serial Clock IO	GPOS Reg Bits 0:1 = '01' GPIS1 Reg Bits 0:1 = '01'
		DA_DEEMPHASIS0	O	Digital Audio De-emphasis indicator bit 0 Output. (See Note 1).	GPOS Reg Bits 0:1 = '10'
		DA_SURMOD0	O	Digital Audio Dolby Surround Mode bit 0. (See Note 2)	GPOS Reg Bits 0:1 = '11'
		TEST_MODE_A	I	Device Test Mode A Enable. (See Note 4)	-
GP01	AD04	GPIO_01	IO	General Purpose Input/Output - Bit 1	GPOS Reg Bits 2:3 = '00'
		I2C1_SDA	B	I <sup>2</sup> C (Inter Integrated Circuit) Bus 1 Serial Data IO	GPOS Reg Bits 2:3 = '01' GPIS1 Reg Bits 2:3 = '01'
		DA_DEEMPHASIS1	O	Digital Audio De-emphasis indicator bit 1 Output. (See Note 1).	GPOS Reg Bits 2:3 = '10'
		DA_SURMOD1	O	Digital Audio Dolby Surround Mode bit 1. (See Note 2)	GPOS Reg Bits 2:3 = '11'
		DEBUG_MODE	I	Debug-Mode Enable. (See Note 4)	-
GP02	AC06	GPIO_02	IO 5V	General Purpose Input/Output - Bit 2	GPOS Reg Bits 4:5 = '00'
		AV_CSYNC	I 5V	Digital Composite Video Sync Output	GPIS1 Reg Bits 4:5 = '01'
		nBI_CS4	O 5V	Auxiliary External Bus - Chip Select 4. Active Low.	GPOS Reg Bits 4:5 = '01'
		DA_SURMOD0	O 5V	Digital Audio Dolby Surround Mode bit 0. (See Note 2)	GPOS Reg Bits 4:5 = '11'
		INT4	I 5V	PowerPC <sup>®</sup> External Interrupt #4 Input	GPIS Reg Bits 4:5 = '11'

Pin Name	Pin No.	Function	Pin Type	Description	Multiplex Configuration
GP03	AF12	GPIO_03	IO	General Purpose Input/Output - Bit 2	GPOS Reg Bits 6:7 = '00'
		SYS_CLK	O	System Clock output (54MHz)	GPOS Reg Bits 6:7 = '01'
		nBI_CS5	O	Auxiliary External Bus - Chip Select 5. Active Low.	GPOS Reg Bits 6:7 = '10'
		INT5	I	PowerPC® External Interrupt #5 Input	GPIS3 Reg Bits 6:7 = '01'
		DA_SURMOD1	O	Digital Audio Dolby Surround Mode bit 1. (See Note 2)	GPOS Reg Bits 6:7 = '11'
		PM15	I	Boot-Option Input - map to PORTMUX Register Bit 15. (See Note 5).	-
GP10	AD07	GPIO_10	IO	General Purpose Input/Output - Bit 10	GPOS Reg Bits 20:21 = '00'
		GPT_CAPT1	I	General Purpose Timer - Capture Timer 1 Input. Typically an Interrupt from an Infrared receiver.	GPIS3 Reg Bits 20:21 = '01'
		nBI_CS7	O	Auxiliary External Bus - Chip Select 7. Active Low.	GPOS Reg Bits 20:21 = '11'
GP16	A04	GPIO_16	IO	General Purpose Input/Output - Bit 16	GPOS Reg Bits 32:33 = '00'
		DA_SERIAL_DATA1	O	Digital Audio Serial Data. Surround channel serial audio data at a rate of 64fs. (Dolby-enabled devices only)	GPOS Reg Bits 32:33 = '01'
		nBI_CS4	O	Auxiliary External Bus - Chip Select 4. Active Low.	GPOS Reg Bits 32:33 = '10'
GP17	C07	GPIO_17	IO	General Purpose Input/Output - Bit 17	GPOS Reg Bits 34:35 = '00'
		DA_SERIAL_DATA2	O	Digital Audio Serial Data. Centre channel/Subwoofer serial audio data at a rate of 64fs. (Dolby-enabled devices only)	GPOS Reg Bits 34:35 = '01'
		nBI_CS5	O	Auxiliary External Bus - Chip Select 5. Active Low.	GPOS Reg Bits 34:35 = '10'
		PM14	I	Boot-Option Input - map to PORTMUX Register Bit 14. (See Note 5).	-

Pin Name	Pin No.	Function	Pin Type	Description	Multiplex Configuration
GP19	D21	GPIO_19	IO 5V	General Purpose Input/Output - Bit 19	GPOS Reg Bits 38:39 = '00'
		GPT_CAPT0	I 5V	General Purpose Timer - Capture Timer 0 Input	GPIS1 Reg Bits 38:39 = '01'
		DV2_VSYNC	IO 5V	<i>Reserved</i>	GPOS Reg Bits 38:39 = '10', GPIS2 Reg Bits 38:39 = '01'
		SSP_FS	I 5V	Synchronous Serial Port for Modem - Frame Sync	GPIS2 Reg Bits 28:29 = '01'
		DA_LR_CH_CLK	I 5V	I <sup>2</sup> S Digital Audio Left-Right Channel Indicator Input. (see Note 3)	CICSEL3 Reg Bit 6 = '1', GPIS2 Reg Bits 28:29 = '01'
GP20	AC11	GPIO_20	IO 5V	General Purpose Input/Output - Bit 20	GPOS Reg Bits 40:41 = '00'
		INT23	I 5V	PowerPC <sup>®</sup> External Interrupt #5 Input	GPIS1 Reg Bits 40:41 = '01'
		DV2_HSYNC	IO 5V	<i>Reserved</i>	GPOS Reg Bits 40:41 = '10', GPIS2 Reg Bits 40:41 = '01'
		SSP_CLK	I 5V	Synchronous Serial Port for Modem - Baud rate clock	GPIS3 Reg Bits 40:41 = '01'
		DA_BIT_CLK	I 5V	I <sup>2</sup> S Digital Audio 64fs clock input. Signal routed through to GP13 (not bonded out)	CICSEL3 Reg Bit 6 = '1', GPIS2 Reg Bits 26:27 = '01'
GP29	AE04	GPIO_29	IO 5V	General Purpose Input/Output - Bit 29	GPOS Reg Bits 58:59 = '00'
		XPT_PWM_OUTPUT	O 5V	System VCXO Pulse-Width modulated Error Signal. (See Note 6)	GPOS Reg Bits 58:59 = '10'

Note 1: DA\_DEEMPHASIS [1:0] have following truth-table: '00' = No emphasis, '01' = 50-15 ms emphasis, '10' = Reserved, '11' = CCITT J.17

Note 2: DA\_SURMOD[1:0] used to indicate whether Dolby Digital encoded stream has been encoded in Dolby Surround.

Note 3: DA\_LR\_CH\_CLK (via GP19) is a clock whose phase indicates the presence of left hand or right hand data, and whose rate is equivalent to fs. Signal routed through to GP14 (not bonded out).

Note 4: GP00 and GP01 inputs are Latched during Power-up only. Active Low Input at power-up to enable Boot Mode functions.

Note 5: GP03 and GP17 inputs are Latched at Power-up only.

Note 6: GP29 XPT\_PWM\_OUTPUT Compensates for frequency errors in 27MHz external VCXO.

## 6.11 Simplified General Purpose Input Output Interface

The Simplified General Purpose Input Output Interface is provided with 8 pins that can be configured as general purpose I/O bits. As there is only one mapped SGPIO signal mapped to each of the pins, the interface is simple, with SGPIO inputs monitored using the SGPI input register, and outputs set using the SGPO register.

The Reserved signals are configured as "Big Endian". This means that DV1\_DATA [0] is the Most Significant Bit (MSB).

Pin Name	Pin No.	Function	Pin Type	Description	Notes
SGPIO2[0]	A11	SGPIO2_0	IO	Simplified General Purpose Input / Output Bus 2 - Bit 0	1
		DV1_DATA[0] (MSB)	B	<i>Reserved</i>	2, 3
SGPIO2[1]	B10	SGPIO2_1	IO	Simplified General Purpose Input / Output Bus 2 - Bit 1	1
		DV1_DATA[1]	B	<i>Reserved</i>	2, 3
SGPIO2[2]	B08	SGPIO2_2	IO	Simplified General Purpose Input / Output Bus 2 - Bit 2	1
		DV1_DATA[2]	B	<i>Reserved</i>	2, 3
SGPIO2[3]	B09	SGPIO2_3	IO	Simplified General Purpose Input / Output Bus 2 - Bit 3	1
		DV1_DATA[3]	B	<i>Reserved</i>	2, 3
		BOOT_MODE	I	Boot Mode. Latched during Power-up only. Pull low with resistor to boot from internal ROM. Leave floating to boot via external memory via BI_CS0.	
SGPIO2[4]	C10	SGPIO2_4	IO	Simplified General Purpose Input / Output Bus 2 - Bit 4	1
		DV1_DATA[4]	B	<i>Reserved</i>	2, 3, 4
SGPIO2[5]	A09	SGPIO2_5	IO	Simplified General Purpose Input / Output Bus 2 - Bit 5	1
		DV1_DATA[5]	B	<i>Reserved</i>	2, 3, 4
SGPIO2[6]	A07	SGPIO2_6	IO	Simplified General Purpose Input / Output Bus 2 - Bit 6	1
		DV1_DATA[6]	B	<i>Reserved</i>	2, 3, 4
SGPIO2[7]	C08	SGPIO2_7	IO	Simplified General Purpose Input / Output Bus 2 - Bit 7	1
		DV1_DATA[7] (LSB)	B	<i>Reserved</i>	2, 3, 4

Note 1: Multiplex setup with CICSEL3 Register Bit 3 = '0'

Note 2: Multiplex setup with CICSEL3 Register Bit 3 = '1'

Note 3: Latched input. Must NOT be pulled Low during chip reset.

Note 4: CICVCR Register Bit 23 = '1' sets DV1\_DATA to an Output, '0' sets to an input

## 6.12 Inter Integrated Circuit (I<sup>2</sup>C) Interface

The I<sup>2</sup>C interface provides a highly programmable interface to the industry-standard I<sup>2</sup>C (inter-integrated circuit) serial bus. The I<sup>2</sup>C device contains a selection of functions that can be programmed to operate as a master, as a slave, or as both a master and a slave on the I<sup>2</sup>C interface. I<sup>2</sup>C, unlike other designs, requires a minimum amount of software to manage the I<sup>2</sup>C bus. In addition to sophisticated I<sup>2</sup>C bus protocol management, the I<sup>2</sup>C device provides full data buffering, eliminating any time-dependent program interaction and further simplifying the task of connecting to the I<sup>2</sup>C bus. The I<sup>2</sup>C interface complies with the Philips<sup>®</sup> Semiconductors I<sup>2</sup>C Specification, dated 1995.

Both the SCL and SDA pins require an external pull-up to 3.3V; *minimum resistor value of 1067 ohms*.

Pin Name	Pin No.	Pin Type	Description
I2C0_SCL	R25	O	I <sup>2</sup> C Bus Clock. Dedicated open drain clock.
I2C0_SDA	R26	O	I <sup>2</sup> C Bus Data. Dedicated open drain serial data/address.

## 6.13 Inter IC Sound (I<sup>2</sup>S) Audio Interface

The PCM Audio Output Controller provides an I<sup>2</sup>S Audio Interface. The audio outputs can be internally muted, and a separate control output is not required. S/PDIF, surround, and center serial outputs can be obtained by using Peripheral or General Purpose Port pins.

Pin Name	Pin No.	Pin Type	Description
DA_BIT_CLK	C06	O	Digital Audio 64fs clock Output
DA_LR_CH_CLK	B04	O	Digital Audio Left-Right Channel Indicator Output. A clock whose phase indicates the presence of left hand or right hand data, and whose rate is equivalent to fs.
DA_OSAMP_CLK	A03	O	Digital Audio Oversampling Clock Output. 512/256 fs clock
DA_SER_DATA0	D06	O	Digital Audio Serial Data Output. Main left and right serial audio data at a rate of 64fs

## 6.14 Clock and Reset Interface

The Clock and Reset interface provides inputs for the 2 primary clock signals, and also a System Reset input.

Pin Name	Pin No.	Pin Type	Description
OSC_PAD	C05		COFDM Crystal Oscillator - 20.48MHz Crystal Connection positive. Also External 20.48MHz CXO Input
OSC_PADN	B03		COFDM Crystal Oscillator - 20.48MHz Crystal Connection negative.
CLK27_IN	C18	I	Main System Clock Input - 27MHz from External VCXO
NG_SYS_RST	A20	I	Power-On Reset Input, from external POR generator. Active Low. <i>Must be held low for at least 100 microseconds after the 1.8V supply has been established.</i>
TMODE	B05	I	Connect to GND in normal operation. Defines production Test Mode B

### 6.15 Power Supply Pins

The ZL10310 and ZL10311 devices operate from 3 voltages; 3.3V for the Input/Outputs, 2.5V for the Video DACs and 1.8V for the SoC Core. The table below shows the pins to which each of the supply voltages should be connected.

Pin Name	Pin No.s	Description	Nominal Voltage Supply
GND	A1, A2, A8, A14, A19, A26, B2, B25, B26, C3, C24, D4, D9, D13, D18, D23, H1, H26, J4, J23, N1, N23, P4, P26, V4, V23, W1, W26, AC4, AC9, AC14, AC18, AC23, AD3, AD24, AE1, AE2, AE25, AF1, AF8, AF13, AF19, AF25, AF26	Digital Ground  <i>(used in parallel with Thermal_GND pins)</i>	0V
VDD_Core	D10, D12, D15, D17, K4, K23, M4, M23, R4, R23, U4, U23, AC10, AC12, AC15, AC17	VDD Supplies to ZL10310/ZL10311 Core	+1.8V wrt GND
VDD_IO	AC5, AC7, AC8, AC19, AC20, AC22, E23, G23, H23, W23, Y23, AB23, D5, D7, D8, D19, D20, D22, E4, G4, H4, W4, Y4, AB4	VDD Supplies to ZL10310/ZL10311 I/O pins	+3.3V wrt GND
AUD_GNDA0	B14	Analog GND for Audio PLL 1	0V
AUD_GNDA1	C15	Analog GND for Audio PLL 2	0V
AUD_VDDA0	B15	Analog VDD for Audio PLL 1	+1.8V wrt AUD_GND
AUD_VDDA1	A16	Analog VDD for Audio PLL 2	+1.8V wrt AUD_GND
CLK_GNDA	A22	Analog GND for System Clock PLL (27MHz)	0V
CLK_VDDA	B20	Analog VDD for System Clock PLL (27MHz)	+3.3V wrt CLK_GND
COFDM_GNDA	A10	Analog GND for COFDM PLL (20.48MHz)	0V
COFDM_VDDA	D11	Analog VDD for COFDM PLL (20.48MHz)	+1.8V wrt COFDM_GND
DAC1_AGND	AE12, AD14, AE16	Analog GND for Video Triple-DAC 1	0V
DAC1_AVDD	AC13, AF14, AF15, AE17	Analog VDD for Video Triple-DAC 1	+2.5V wrt DAC1_AGND
DAC2_AGND	AF09, AE08, AE07	Analog GND for Video Triple-DAC 2	0V

Pin Name	Pin No.s	Description	Nominal Voltage Supply
DAC2_AVDD	AD12, AD11, AE06, AD08	Analog VDD for Video Triple-DAC 2	+2.5V wrt DAC2_AGND
Thermal_GND	L11, L12, L13, L14, L15, L16, M11, M12, M13, M14, M15, M16, N11, N12, N13, N14, N15, N16, P11, P12, P13, P14, P15, P16, R11, R12, R13, R14, R15, R16, T11, T12, T13, T14, T15, T16	Thermal Ground pins (used in parallel with Digital GND pins (GND))	0V

### 6.16 Reserved Connections

The following pins have no specific function allocated, and are reserved.

Pin No.	Pin Type	Connection
W25	Analog IO	NOT CONNECTED
U24	Analog IO	NOT CONNECTED
R24	Analog IO	NOT CONNECTED
T25	Analog IO	NOT CONNECTED
AE03	O 5V	NOT CONNECTED
AD01	O 5V	NOT CONNECTED
AD02	O 5V	NOT CONNECTED
AB03	B 5V	NOT CONNECTED

## 7.0 Characteristics

### 7.1 AC and DC Electrical Characteristics

#### Absolute Maximum Ratings

Parameter	Min	Max	Units
Supply voltage wrt GND, 1.8 V supply		+2.3	V
Supply voltage wrt GND, 2.5V supply		+3.0	V
Supply voltage wrt GND, 3.3 V supply		+3.9	V
Storage temperature	-65	150	°C
Bias for 5V inputs		+5.5	V
Input Voltage (any input pin)	(GND-0.5)	(Vdd_IO+0.5)	V
Output Voltage (any output pin)	(GND-0.5)	(Vdd_IO+0.5)	V
ESD Rating (Static Discharge)		±3k	V
Max Junction Temperature		110	°C

#### DC Characteristics

Symbol	Parameter	Min	Typ	Max	Unit	Conditions
TA	Operating Free Air Temperature	0°		70°	C	
$\theta_{jc}$	Thermal Resistance, Junction to Case		18		°C/Watt	
VDD_CORE	Digital Core Supply Voltage	1.71	1.80	1.89	V	
VDD_IO	Digital IO Supply Voltage	3.14	3.30	3.47	V	
AUD_VDDA0, 1	Audio Clock PLL Supply Voltage	1.71	1.80	1.89	V	
CLK_VDDA	System Clock PLL Supply Voltage	3.14	3.30	3.47	V	
COFDM_VDDA	COFDM Oscillator Supply Voltage	1.71	1.80	1.89	V	
DAC1_AVDD	Video Triple-DAC 1 Supply Voltage	2.38	2.50	2.62	V	
DAC2_AVDD	Video Triple-DAC 2 Supply Voltage	2.38	2.50	2.62	V	
IDD_CORE	Supply Current, 1.8 V		550	750	mA	VDD_CORE = Max
IDD_DACS	Supply Current, 2.5 V		80	100	mA	DACx_AVDD = Max

**DC Characteristics**

<b>Symbol</b>	<b>Parameter</b>	<b>Min</b>	<b>Typ</b>	<b>Max</b>	<b>Unit</b>	<b>Conditions</b>
IDD_IO	Supply Current, 3.3 V		40	75	mA	VDD_IO = Max
PD	Power Dissipation		1.78	2.0	W	ALL VDD pins = Max
CLK27_IN_Freq	System Input Clock Frequency		27		MHz	External VCXO
COFDM_OSC_Freq	COFDM Input Clock Frequency		20.48		MHz	External Crystal Oscillator
COFDM_OSC_Tol	COFDM Crystal Oscillator Tolerance		±50		ppm	



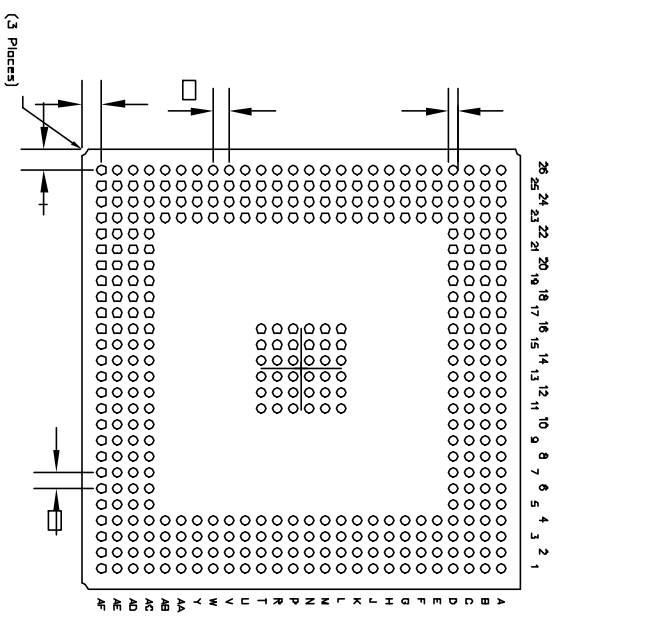
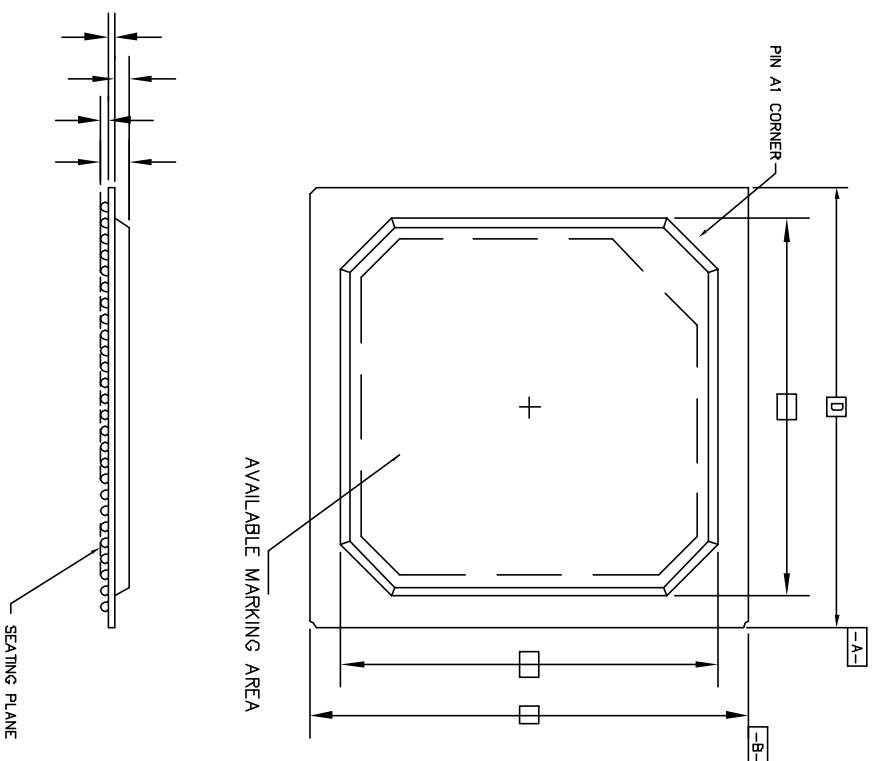

SYMBOL	CONTROL DIMENSIONS ( mm )			NOTE
	MIN.	NOM.	MAX.	
A	-	-	2.65	
A <sub>1</sub>	0.30	-	-	
A <sub>2</sub>	-	27.00	-	
D	26.80	27.00	27.20	
D <sub>1</sub>	25.00 BSC			
E	26.80	27.00	27.20	
E <sub>1</sub>	25.00 BSC			
I	-	-	-	
J	-	-	-	
b	0.50	0.60	0.70	
c	-	-	-	
d	-	-	-	
e	-	1.00	-	
f	-	-	-	

NOTES: -  
 1. ALL DIMENSIONS AND TOLERANCES CONFORM TO ANSI Y14.5M-1994  
 2. THIS DWG CONFORMS TO JEDEC MS-034A

© Zarlink Semiconductor 2002 All rights reserved.

ISSUE	1			
ACN	213807			
DATE	25Nov02			
APPRD.				



Previous package codes

Package Code

Package Outline for  
388EPBGA 27 x 27

GPD000807



**For more information about all Zarlink products  
visit our Web Site at  
[www.zarlink.com](http://www.zarlink.com)**

Information relating to products and services furnished herein by Zarlink Semiconductor Inc. or its subsidiaries (collectively "Zarlink") is believed to be reliable. However, Zarlink assumes no liability for errors that may appear in this publication, or for liability otherwise arising from the application or use of any such information, product or service or for any infringement of patents or other intellectual property rights owned by third parties which may result from such application or use. Neither the supply of such information or purchase of product or service conveys any license, either express or implied, under patents or other intellectual property rights owned by Zarlink or licensed from third parties by Zarlink, whatsoever. Purchasers of products are also hereby notified that the use of product in certain ways or in combination with Zarlink, or non-Zarlink furnished goods or services may infringe patents or other intellectual property rights owned by Zarlink.

This publication is issued to provide information only and (unless agreed by Zarlink in writing) may not be used, applied or reproduced for any purpose nor form part of any order or contract nor to be regarded as a representation relating to the products or services concerned. The products, their specifications, services and other information appearing in this publication are subject to change by Zarlink without notice. No warranty or guarantee express or implied is made regarding the capability, performance or suitability of any product or service. Information concerning possible methods of use is provided as a guide only and does not constitute any guarantee that such methods of use will be satisfactory in a specific piece of equipment. It is the user's responsibility to fully determine the performance and suitability of any equipment using such information and to ensure that any publication or data used is up to date and has not been superseded. Manufacturing does not necessarily include testing of all functions or parameters. These products are not suitable for use in any medical products whose failure to perform may result in significant injury or death to the user. All products and materials are sold and services provided subject to Zarlink's conditions of sale which are available on request.

Purchase of Zarlink's I<sup>2</sup>C components conveys a licence under the Philips I<sup>2</sup>C Patent rights to use these components in and I<sup>2</sup>C System, provided that the system conforms to the I<sup>2</sup>C Standard Specification as defined by Philips.

Zarlink, ZL and the Zarlink Semiconductor logo are trademarks of Zarlink Semiconductor Inc.

Copyright Zarlink Semiconductor Inc. All Rights Reserved.

**TECHNICAL DOCUMENTATION - NOT FOR RESALE**

---