



# ZL40800 and ZL40802

## 6 GHz Fixed Modulus Prescalers ÷ 8 and ÷ 16

Data Sheet

### Features

- 3.45V Single Supply Operation
- Low Power Dissipation: 190mW typ
- Broadband: DC to 6GHz
- SSB Phase Noise (-153dBc/Hz @ 10KHz)
- Pout 3dBm

### Prescaler Modulus

- ZL40800 – Divide by 8
- ZL40802 – Divide by 16

### Applications

- DC to 6 GHz PLL applications
- HyperLan
- LMDS
- Instrumentation
- Satellite Communications
- Fibre Optic Communications; OC48, OC192
- Ultra Low Jitter Clock Systems

July 2003

### Ordering Information

ZL40800/DCA (tubes)	8 pin SOIC
ZL40800/DCB (tape and reel)	8 pin SOIC
ZL40802/DCA (tubes)	8 pin SOIC
ZL40802/DCB (tape and reel)	8 pin SOIC

-40°C to 85°C

### Description

The ZL40800 and ZL40802 are Bipolar 3.45V supply, very low power prescalers for professional applications with a fixed modulus of 8 or 16. The ultra low close in (1KHz offset) SSB phase noise performance is ideal for narrow band communications systems or systems with ultra low jitter budgets such as next generation fibre optic communications. The devices are broadband from DC to 6GHz.

See Figure 1 and Application Note for RF Prescalers for more details.

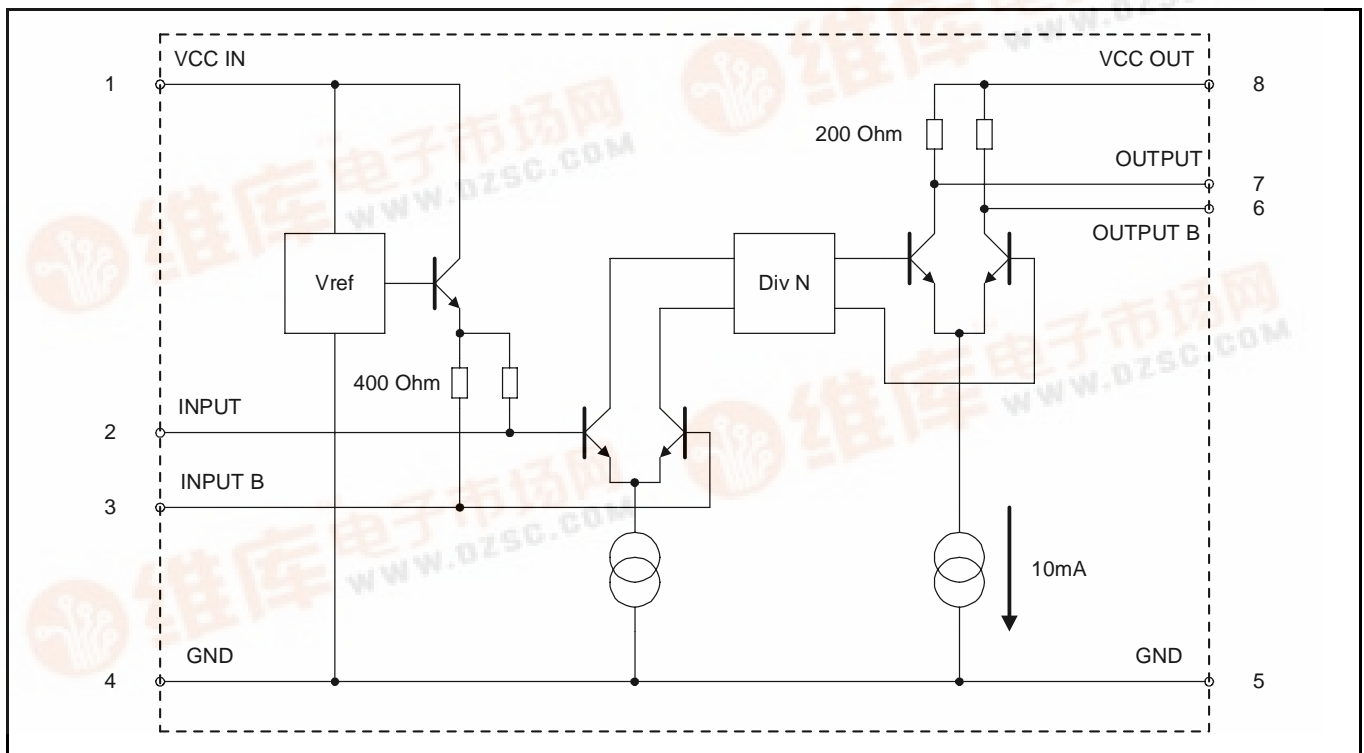
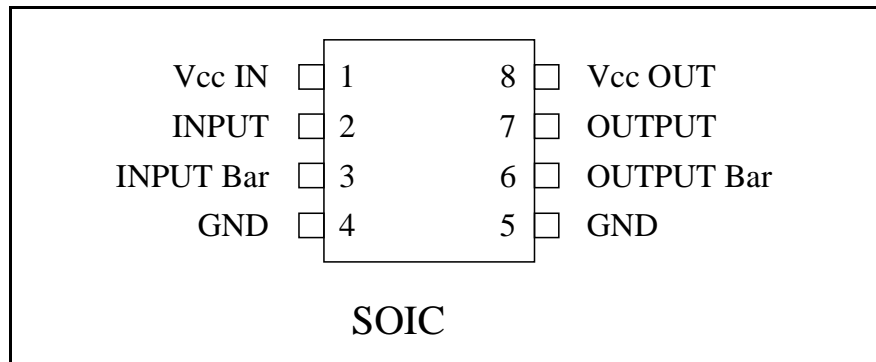

Figure 1 - Block Diagram

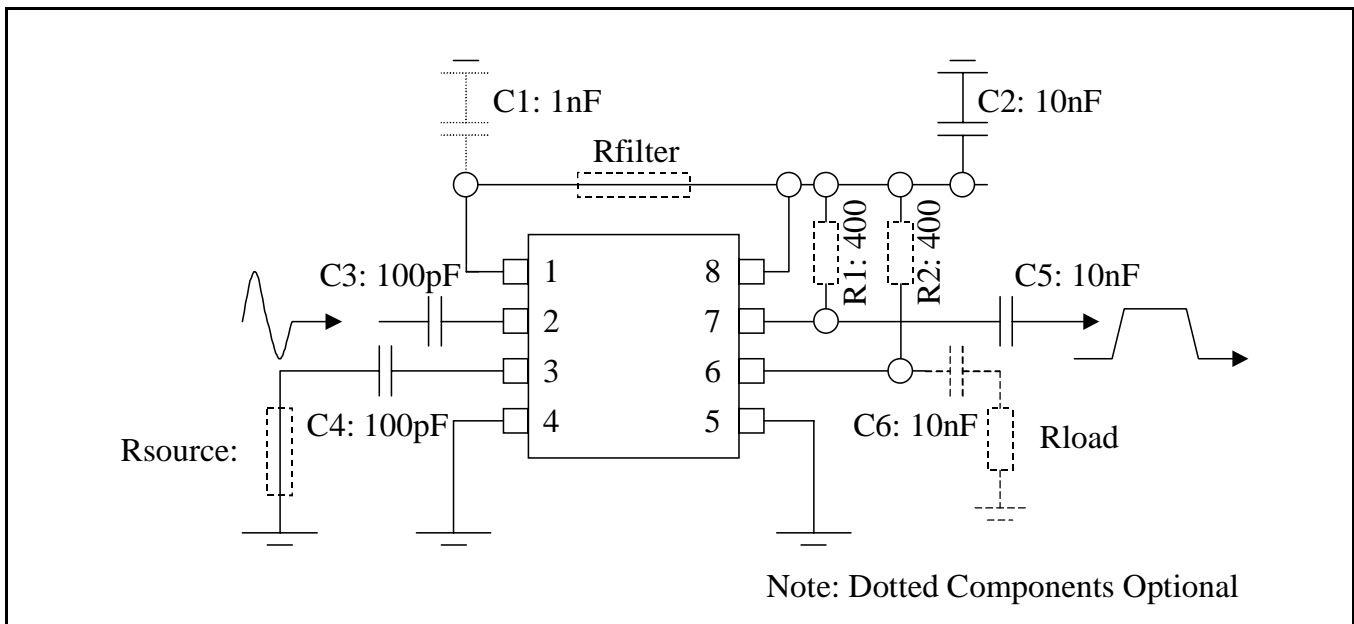



**Figure 2 - Pin Connections - Top View**

**Application Configuration**

Figure 3 shows a recommended application configuration. This example shows the device set up for single ended operation.



**Figure 3 - Recommended circuit configuration**

This represents the circuit used to complete characterisation. The tabulated Electrical performance is guaranteed using this application circuit.

Unpopulated evaluation boards are available, type No. ZLE40008. Fully populated evaluation boards are also available, type Nos. ZLE40800 and ZLE40802.

### Circuit Options

The application circuit includes some optional components that may be required to improve tolerance of system noise present in the application.

**Dummy R source** may be added to the inverting input to provide a better matched source impedance at the input. This will improve the rejection of common mode noise present within the system.

**Dummy R load** may be added to the inverting output to provide better matched load at the output. This will reduce the radiated EMI at the output and reduce the Output Noise present on the supply rail.

**R1 and R2 400 Ohm Pull ups** are added to increase the headroom present at the amplifier output. This enhances the operation at maximum supply and temperature. An alternative is to provide an inductive choke in place of R1 and R2.

These components provide a parallel DC Path to Vcc increasing the bandwidth of the output stage and providing a virtually flat output power across frequency. See Fig 12 and 13.

**Rfilter** can be inserted between the Vcc in and the Vcc\_out to provide additional filtering to the input Vcc. The input Vcc powers the input bias reference only and can be a sensitive point to system noise. The nominal input current at Vcc\_IN is 0.35mA. An alternative would be to use an inductive choke.

**C1** is additional Supply Filtering and should be added with Rfilter. The IC includes 10pF of on Chip Supply Filtering.

### Input and Output Circuit

Figure 4 shows the equivalent input and output circuit.

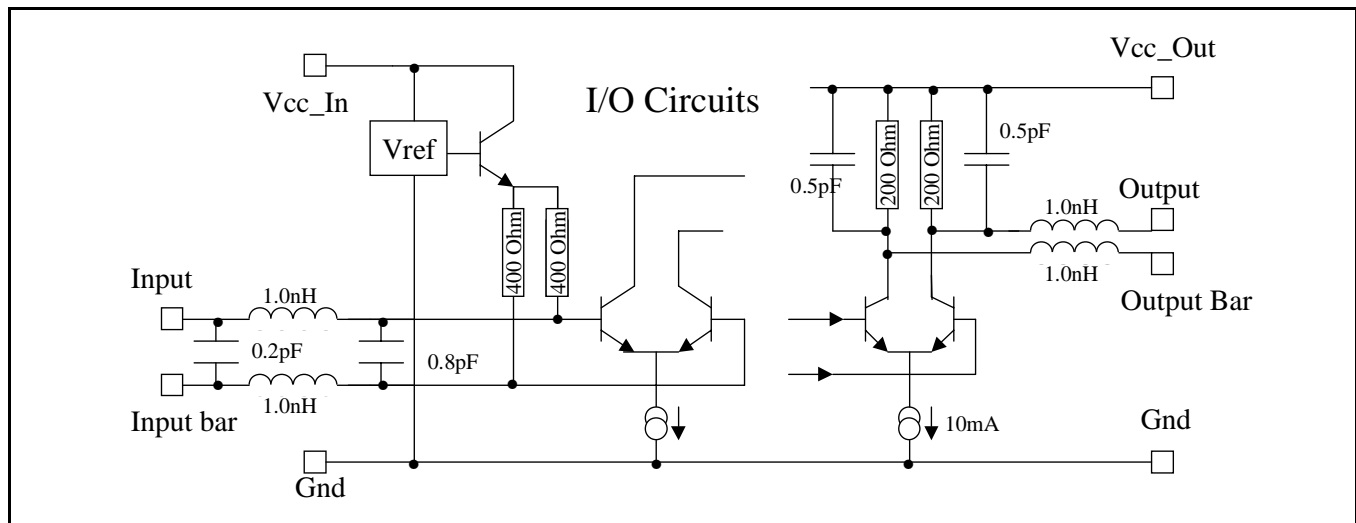

Figure 4 - Input and Output Equivalent Circuit

### Increase Output Power Output Match and Narrow Band Operating Range

The device has been characterised with a mismatch at the output. This is a broadband configuration. 3dB more output power is available if the application matches the load to the output impedance.

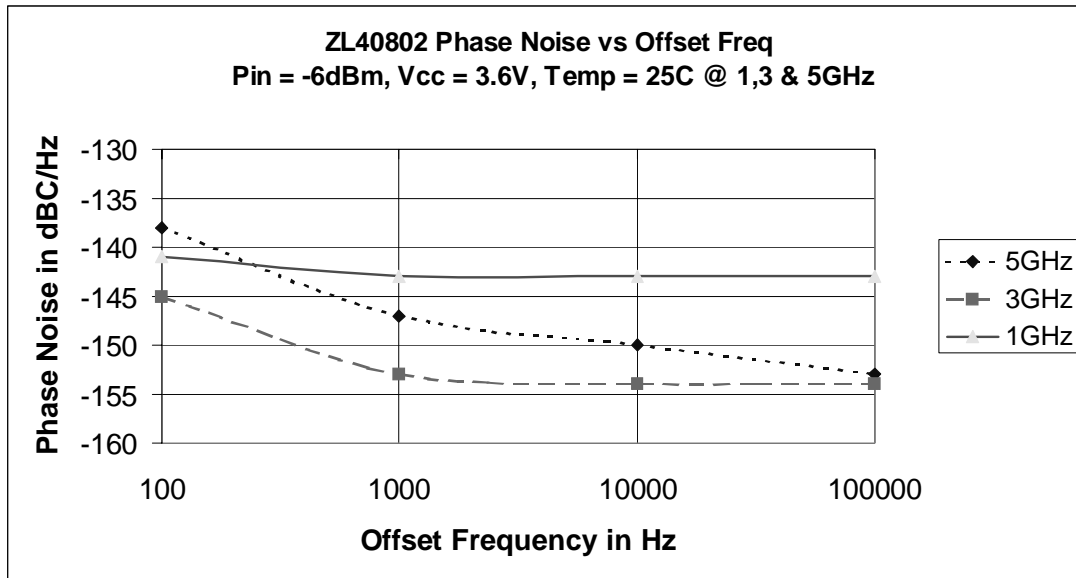

Figure 5 - ZL40802 Typical Phase Noise

#### Absolute Maximum Ratings

	Parameter	Symbol	Min	Max	Units
1	Supply voltage	Vcc	-0.5	6	V
2	RFin			12	dBm
3	All I/O ports		-0.5	+0.5	V
4	ESD protection		2k		V Mil-std 883B / 3015 cat1
5	Storage temperature		-55	+150	°C

#### Operating Range

	Parameter	Symbol	Min	Max	Units
1	Supply voltage	Vcc	3.3	3.6	V
2	RFin Frequency Range		0.1	6	GHz
3	Operating Junction Temperature		-40	125	°C
4	Junc'n to Amb't resistance	Rth (j-a)	150		°C/W 4 layer FR4 Board
5	Junc'n to Amb't resistance	Rth (j-c)	60		°C/W 4 layer FR4 Board

## AC/DC Electrical Characteristics

### Electrical Characteristics<sup>†</sup>

Characteristic	Pin	Min.	Typ.	Max.	Units	Conditions
I <sub>cc_in</sub> (Supply current)	1		0.35		mA	ZL40800 Div8 & ZL40802 Div16
I <sub>cc_out</sub> (Supply current)	8	29	52	86	mA	ZL40800 Div8
I <sub>cc_out</sub> (Supply current)	8	31	55	89	mA	ZL40802 Div16
Input frequency	2,3	1		6	GHz	RMS sinewave,
Input sensitivity	2,3		-20	-10	dBm	f <sub>in</sub> = 1GHz to 6GHz, Note 1
Input overload	2,3	4	10		dBm	f <sub>in</sub> = 1GHz to 6GHz, Note 1
Phase Noise	6,7		-150		dBc/Hz	@ 1KHz Offset f <sub>in</sub> = 3GHz
Output voltage	6,7		1		Vp-p	Differential Into 50ohm pull up resistors
Output power	6,7	-7	-2	2	dBm	f <sub>in</sub> = 1GHz to 6GHz, P <sub>in</sub> = -10dBm Note 2
Output t-rise	6,7		110		ps	f <sub>in</sub> = 1GHz to 6GHz, P <sub>in</sub> = -10dBm
Output t-fall	6,7		110		ps	f <sub>in</sub> = 1GHz to 6GHz, P <sub>in</sub> = -10dBm
T – prop delay	2,6		250		ps	50% IN to 50% OUT
Jitter	6,7		0.1		ps	
Output Duty Cycle	6,7	45	50	55	%	f <sub>in</sub> = 1GHz to 6GHz, I <sub>n</sub> = -10dBm
Input Edge Speed	2,3	500			V/us	For < 1GHz input operation

<sup>†</sup> These characteristics are guaranteed by design and characterisation over the following range of operating conditions unless otherwise stated:  
T<sub>amb</sub> = -40C to + 85C, V<sub>cc</sub> = 3.3V to 3.6V.

Note 1: P<sub>in</sub> = power measured into 50 ohm Load from 50 Ohm Source.

Note 2: P<sub>out</sub> Single Ended AC coupled Single 50 Ohm Termination

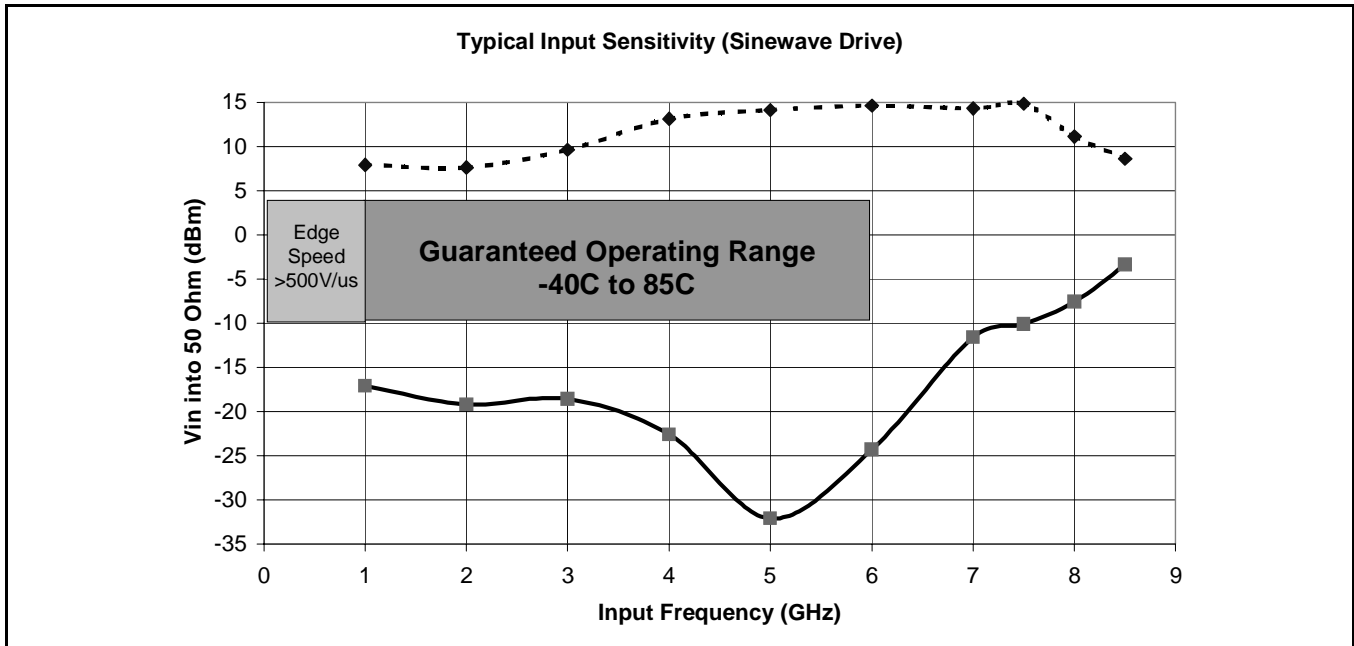

Figure 6 - Typical Input Sensitivity (sine wave drive)

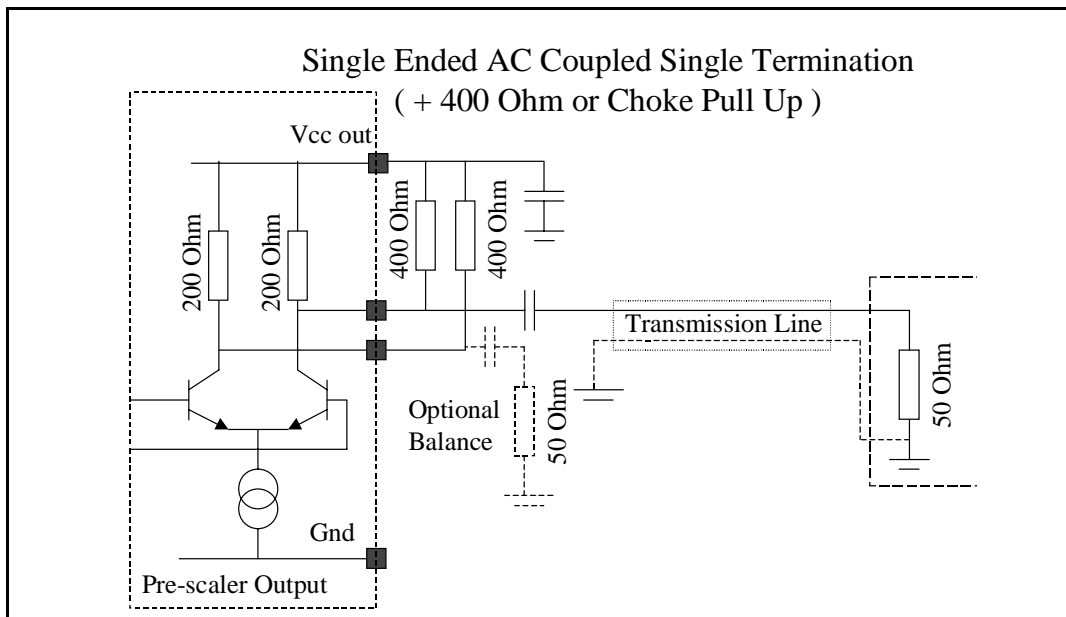

Figure 7 - Single Ended AC Coupled Single Termination

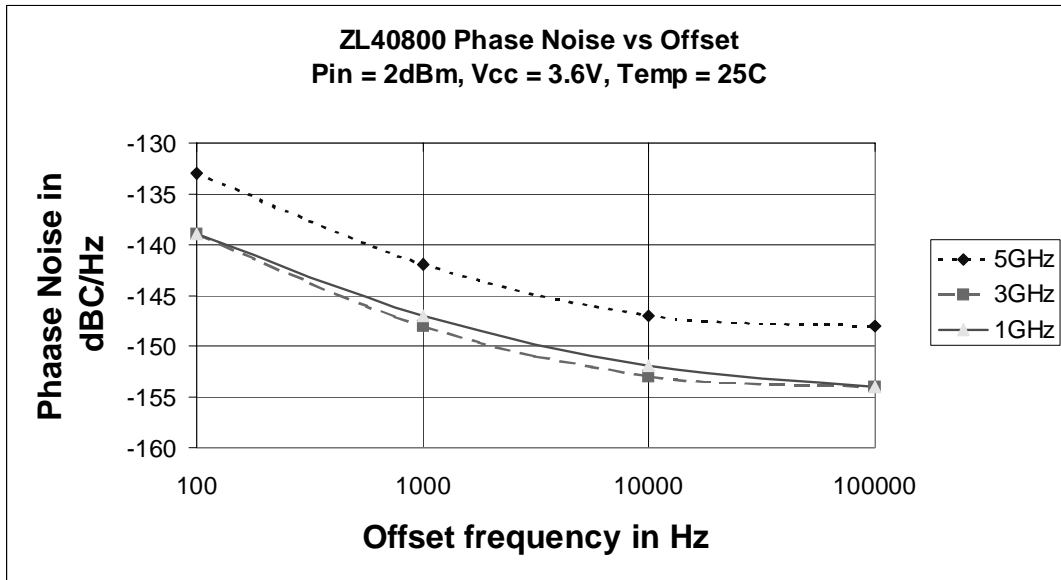

Figure 8 - ZL40800 Typical Phase Noise

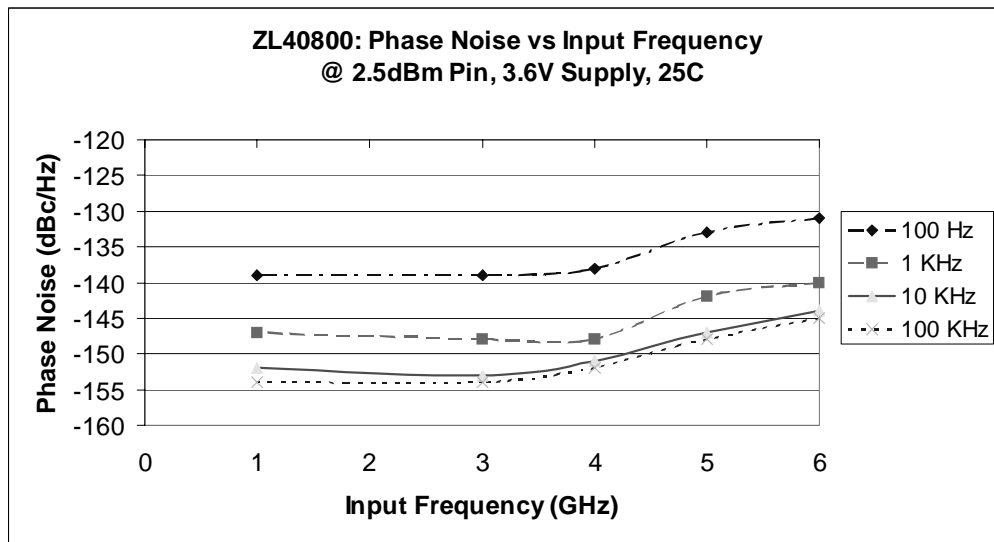

Figure 9 - ZL40800 Phase Noise vs Input Frequency

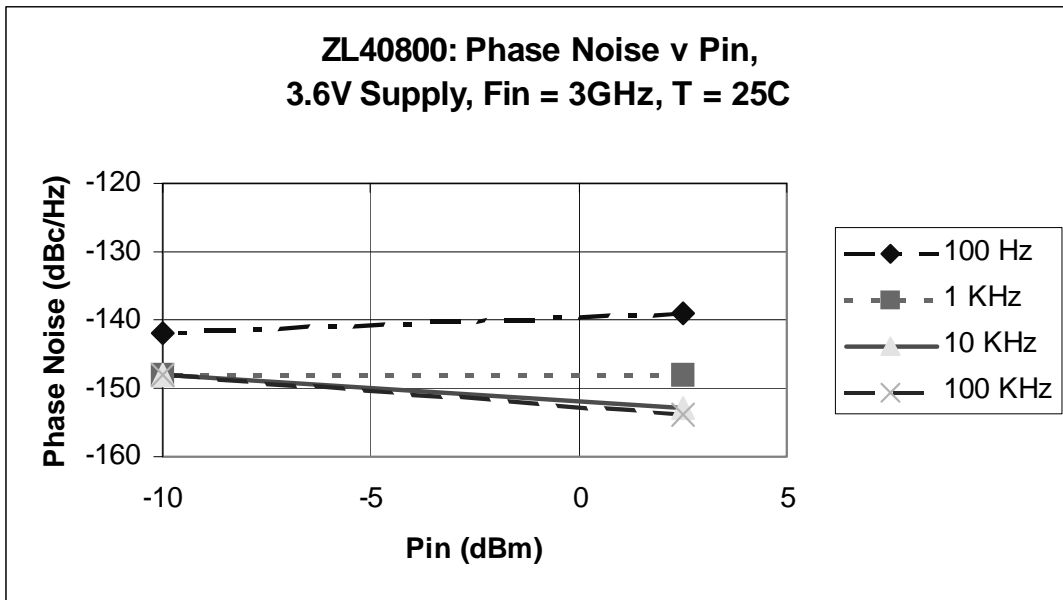

Figure 10 - ZL40800 Phase Noise vs Input Power

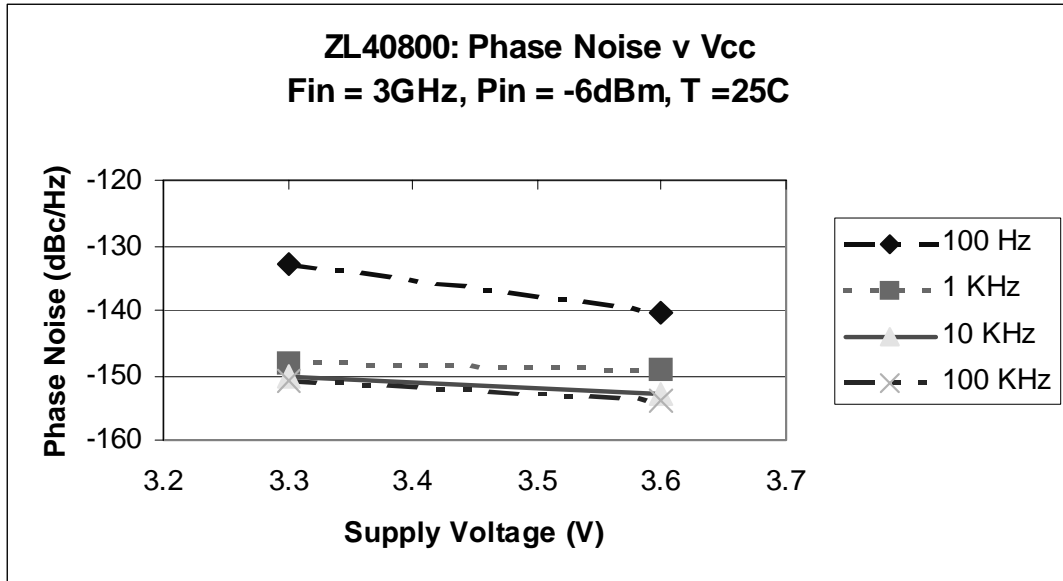

Figure 11 - ZL40800 Phase Noise vs Vcc



**Single Ended or Differential Load**

Figure 12 and Figure 13 illustrate the output waveform when measured differential and single ended with a 6GHz waveform at the input at a level of +2dBm. The single ended output contains some input frequency breakthrough which contributes to the distortion present. This is a common mode signal which is rejected if the output is taken differentially.

Differential operation also provides an additional 3dB. Differential Operation reduces the radiated EMI in the system and reduces the susceptibility to common mode system noise.

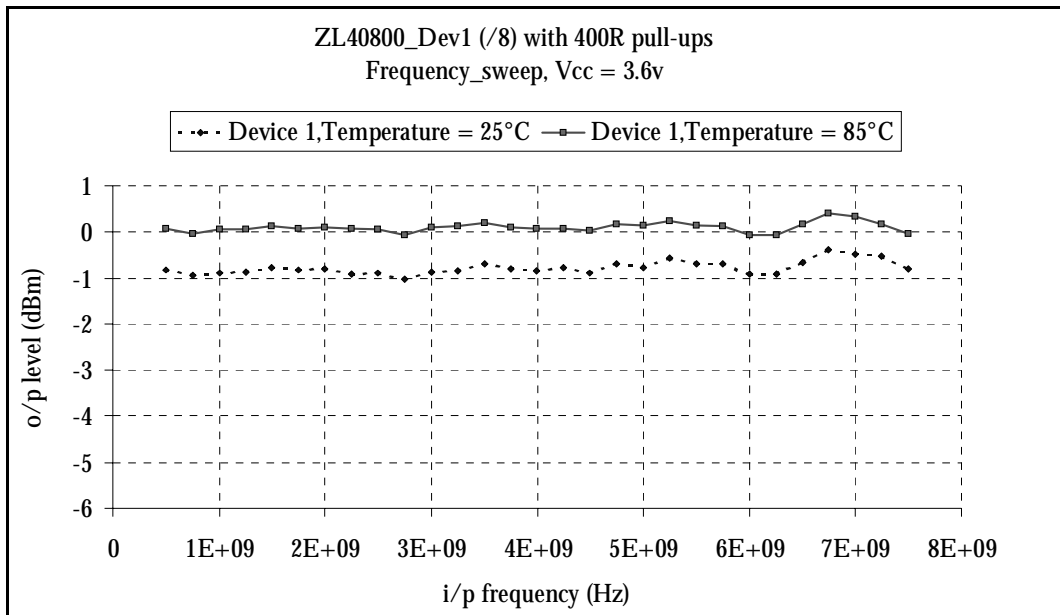

**Figure 12 - ZL40800 Pout / Input Frequency**

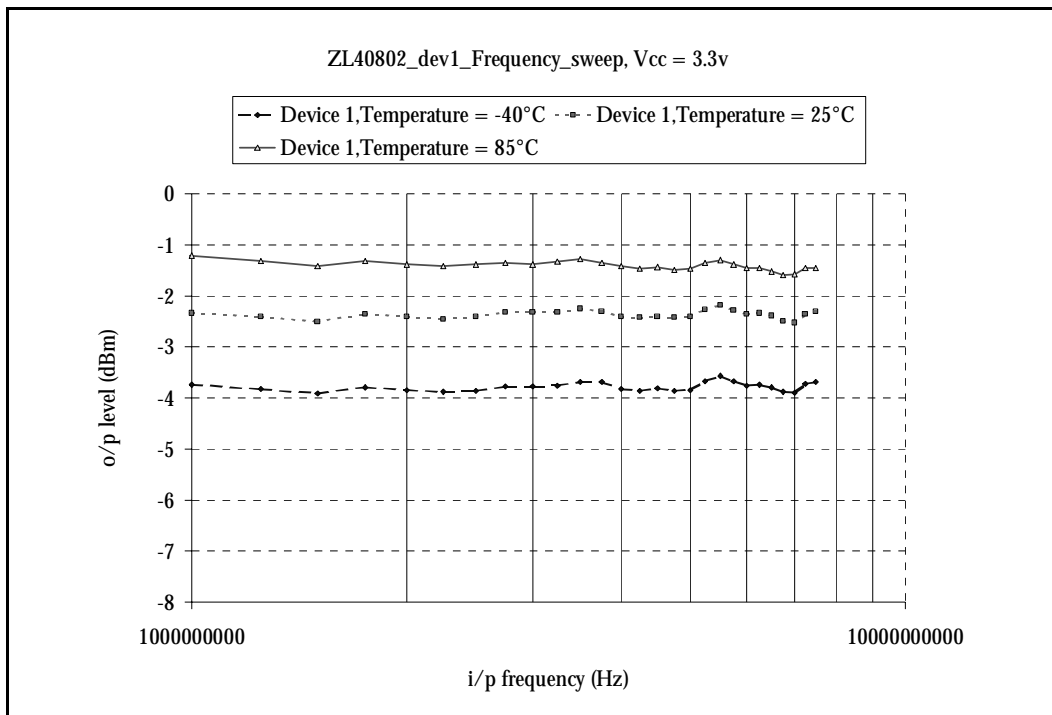

**Figure 13 - ZL40800 Pout v Input Frequency (Vcc=3.3V, T= -40C, 25C, 85C)**

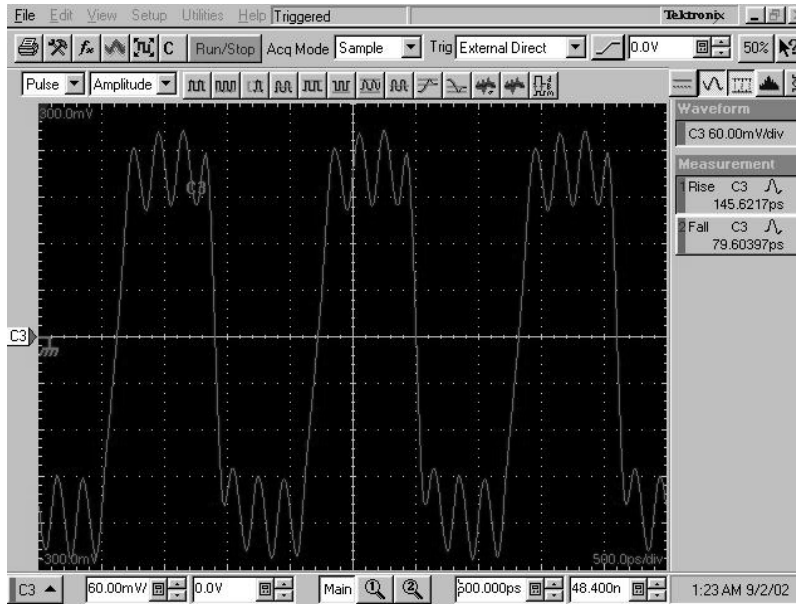

Figure 14 - ZL40800 Single Ended Out @ 5Ghz +2dBm

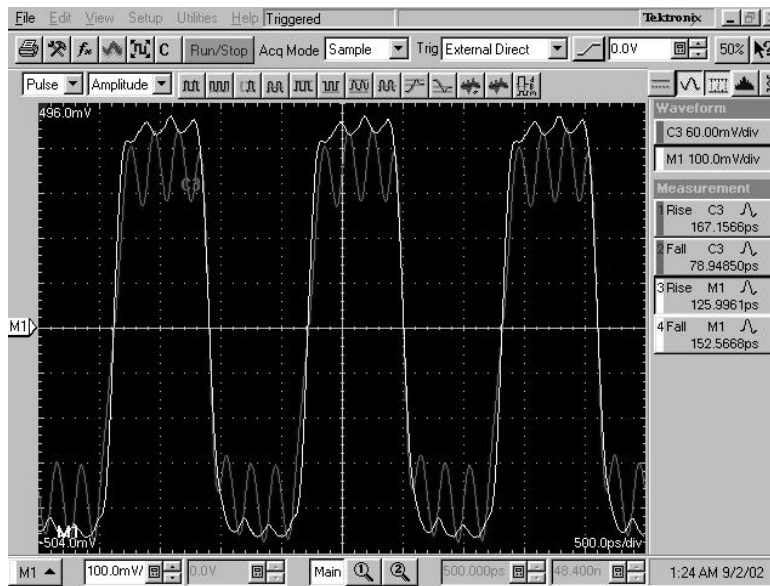
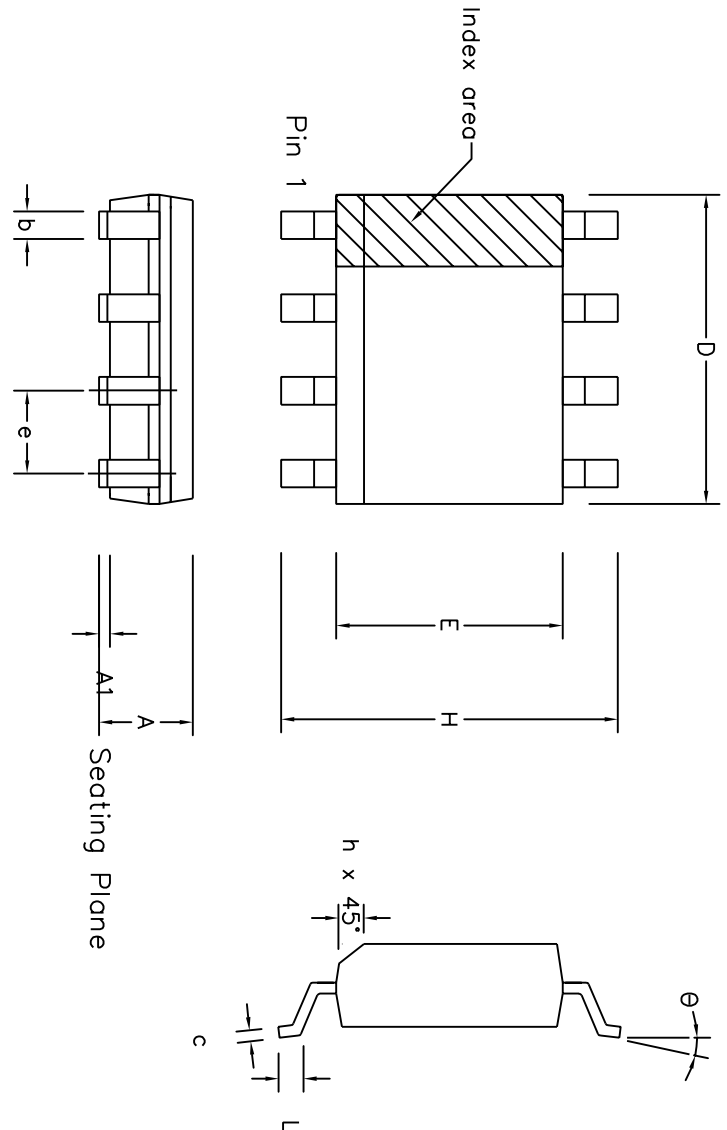

Figure 15 - ZL40800 Differential Out @ 5Ghz +2dBm



	Min mm	Max mm	Min inch	Max inch
A	1.35	1.75	0.053	0.069
A1	0.10	0.25	0.004	0.010
D	4.80	5.00	0.189	0.197
H	5.80	6.20	0.228	0.244
E	3.80	4.00	0.150	0.157
L	0.40	1.27	0.016	0.050
e	1.27	BSC	0.050	BSC
b	0.33	0.51	0.013	0.020
c	0.19	0.25	0.008	0.010
Ø	0°	8°	0°	8°
h	0.25	0.50	0.010	0.020
Pin Features				
N	8		8	
Conforms to JEDEC MS-012AA Iss. C				

- Notes:
1. The chamfer on the body is optional. If not present, a visual index feature, e.g. a dot, must be located within the cross-hatched area.
  2. Controlling dimensions are in inches.
  3. Dimension D do not include mould flash, protusion or gate burrs. These shall not exceed 0.006" per side.
  4. Dimension E1 do not include inter-lead flash or protusion. These shall not exceed 0.010" per side.
  5. Dimension b does not include dambar protusion / intrusion. Allowable dambar protusion shall be 0.004" total in excess of b dimension.

© Zarlink Semiconductor 2002 All rights reserved.

ISSUE	1	2	3	4	5
ACN	6745	201936	202595	203705	212424
DATE	5Apr95	27Feb97	12Jun97	9Dec97	22Mar02
APPRD.					



Previous package codes	Package Code	Package Outline for
MP / S	DC	8 lead SOIC (0.150" Body width)
		GPD000010



**For more information about all Zarlink products  
visit our Web Site at  
[www.zarlink.com](http://www.zarlink.com)**

Information relating to products and services furnished herein by Zarlink Semiconductor Inc. or its subsidiaries (collectively "Zarlink") is believed to be reliable. However, Zarlink assumes no liability for errors that may appear in this publication, or for liability otherwise arising from the application or use of any such information, product or service or for any infringement of patents or other intellectual property rights owned by third parties which may result from such application or use. Neither the supply of such information or purchase of product or service conveys any license, either express or implied, under patents or other intellectual property rights owned by Zarlink or licensed from third parties by Zarlink, whatsoever. Purchasers of products are also hereby notified that the use of product in certain ways or in combination with Zarlink, or non-Zarlink furnished goods or services may infringe patents or other intellectual property rights owned by Zarlink.

This publication is issued to provide information only and (unless agreed by Zarlink in writing) may not be used, applied or reproduced for any purpose nor form part of any order or contract nor to be regarded as a representation relating to the products or services concerned. The products, their specifications, services and other information appearing in this publication are subject to change by Zarlink without notice. No warranty or guarantee express or implied is made regarding the capability, performance or suitability of any product or service. Information concerning possible methods of use is provided as a guide only and does not constitute any guarantee that such methods of use will be satisfactory in a specific piece of equipment. It is the user's responsibility to fully determine the performance and suitability of any equipment using such information and to ensure that any publication or data used is up to date and has not been superseded. Manufacturing does not necessarily include testing of all functions or parameters. These products are not suitable for use in any medical products whose failure to perform may result in significant injury or death to the user. All products and materials are sold and services provided subject to Zarlink's conditions of sale which are available on request.

Purchase of Zarlink's I<sup>2</sup>C components conveys a licence under the Philips I<sup>2</sup>C Patent rights to use these components in and I<sup>2</sup>C System, provided that the system conforms to the I<sup>2</sup>C Standard Specification as defined by Philips.

Zarlink, ZL and the Zarlink Semiconductor logo are trademarks of Zarlink Semiconductor Inc.

Copyright Zarlink Semiconductor Inc. All Rights Reserved.

**TECHNICAL DOCUMENTATION - NOT FOR RESALE**

---