



ZL60101/2

12 x 2.7 Gbps Parallel Fiber Optic Link Transmitter and Receiver

Data Sheet

June 2004

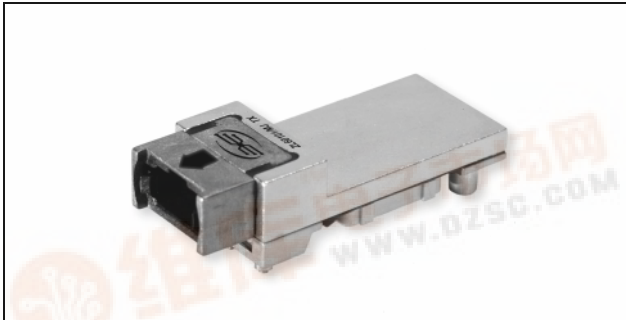

Ordering Information

ZL60101/MJD Parallel Fiber Transmitter
ZL60102/MJD Parallel Fiber Receiver

Heat sink and EMI shield options
are available upon request

0°C to +80°C

Features

- 12 parallel channels, total 32.6 Gbps capacity
- Data rate up to 2.72 Gbps per channel
- 850 nm VCSEL array
- Data I/O is CML compatible with DC blocking capacitors
- Link reach 300 m with 50/125 μm 500 MHz·km fiber at 2.5 Gbps
- Channel BER better than 10^{-12}
- Industry standard MPO/MTP™ ribbon fiber connector interface
- Pluggable MegArray® ball grid array connector
- Optionally available with EMI shield and external heat sink
- Laser class 1M IEC 60825-1:2001 compliant
- Power supply 3.3 V
- Compatible with industry MSA

Applications

- High-speed interconnects within and between switches, routers and transport equipment
- Proprietary backplanes
- Low cost SONET/SDH VSR (Very Short Reach) OC-192/STM64 connections
- InfiniBand® connections
- Interconnects rack-to-rack, shelf-to-shelf, board-to-board, board-to-optical backplane

Description

The ZL60101 and ZL60102 together make a very high speed transmitter/receiver pair for parallel fiber applications.

The ZL60101 transmitter module converts parallel electrical input signals via a laser driver and a VCSEL array into parallel optical output signals at a wavelength of 850 nm.

The ZL60102 receiver module converts parallel optical input signals via a PIN photodiode array and a transimpedance and limiting amplifier into electrical output signals.

The modules are pluggable each fitted with an industry-standard MegArray® BGA connector. This provides ease of assembly on the host board and enables provisioning of bandwidth on demand.

Table of Contents

Features	1
Applications	1
Description	1
Absolute Maximum Ratings	3
Recommended Operating Conditions	3
ZL60101 Transmitter Specifications	4
Transmitter Control and Status Signals	6
Transmitter Control and Status Timing Diagrams	7
Transmitter Pinout Assignments	9
Transmitter Pin Description	9
ZL60102 Receiver Specifications	10
Receiver Control and Status Signals	11
Receiver Control and Status Timing Diagrams	12
Receiver Pinout Assignments	13
Receiver Pin Description	13
Thermal Characteristics	14
Regulatory Compliance	15
Eye Safety	15
Electrostatic Discharge	15
Electrostatic Discharge Immunity	15
Electromagnetic Interference	15
Emission	15
Immunity	15
Handling instructions	15
Cleaning the Optical Interface	15
Connectors	15
ESD Handling	15
Link Reach	16
Link Model Parameters	16
Electrical Interface - Application Examples	17

Absolute Maximum Ratings

Not necessarily applied together. Exceeding these values may cause permanent damage. Functional operation under these conditions is not implied.

Parameter	Symbol	Min.	Max.	Unit
Supply voltage	V_{CC}	-0.3	4.0	V
Differential input voltage amplitude ¹	ΔV		1.2	V
Voltage on any pin	V_{PIN}	-0.3	$V_{CC} + 0.3$	V
Relative humidity (non-condensing)	M_{OS}	5	95	%
Storage temperature	T_{STG}	-40	100	°C
ESD resistance	V_{ESD}		± 1	kV

1. Differential input voltage amplitude is defined as $\Delta V = |DIN+ - DIN-|$.

Recommended Operating Conditions

These parameters apply both to the transmitter and the receiver.

Parameter	Symbol	Min.	Max.	Unit
Power supply voltage	V_{CC}	3.135	3.465	V
Operating case temperature	T_{CASE}	0	80	°C
Signaling rate (per channel) ¹	f_D	1.0	2.72	Gbps
Link distance ²	LD	2		m
Data I/O DC blocking capacitors ³	C_{BLK}	100		nF
Power supply noise ⁴	V_{NPS}		200	mV _{p-p}

1. Data patterns are to have maximum run lengths and DC balance shifts no worse than that of a Pseudo Random Bit Sequence of length $2^{23}-1$ (PRBS-23). Information on lower bit rates is available on request.

2. For maximum distance, see Table 6.

3. For AC-coupling, DC blocking capacitors external to the module with a minimum value of 100 nF is recommended.

4. Power supply noise is defined at the supply side of the recommended filter for all V_{CC} supplies over the frequency range of 500 Hz to 2720 MHz with the recommended power supply filter in place.

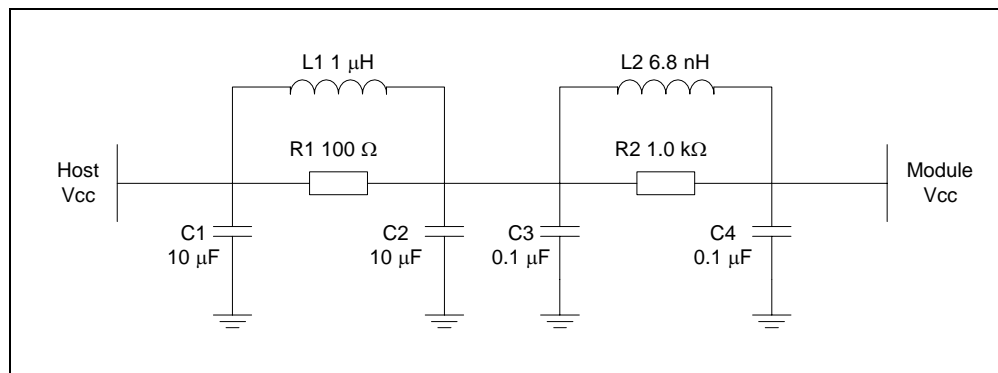

Figure 1 - Recommended Power Supply Filter

ZL60101 Transmitter Specifications

All parameters below require operating conditions according to “Recommended Operating Conditions” on page 3.

Parameter	Symbol	Min.	Max.	Unit
<i>Optical Parameters</i>				
Launch power (50/125 μm MMF) ¹	P_{OUT}	-7.5	-2	dBm
Extinguished output power	P_{OFF}		-30	dBm
Extinction ratio ²	ER	7		dB
Optical modulation amplitude ³	OMA	0.24		mW
Center wavelength	λ_{C}	830	860	nm
Spectral width ⁴	$\Delta\lambda$		0.85	nm _{rms}
Relative intensity noise OMA	$\text{RIN}_{12\text{OMA}}$		-116	dB/Hz
Optical output rise time (20 - 80%)	t_{RO}		150	ps
Optical output fall time (20 - 80%)	t_{FO}		150	ps
Total jitter contributed (peak to peak) ⁵	TJ		120	ps
Deterministic jitter contributed (peak to peak)	DJ		50	ps
Channel to channel skew ⁶	t_{SK}		100	ps
<i>Electrical Parameters</i>				
Power dissipation	P_{D}		1.5	W
Supply current	I_{CC}		450	mA
Differential input voltage amplitude (peak to peak) ⁷	ΔV_{IN}	200	800	mV _{p-p}
Differential input impedance ⁸	Z_{IN}	80	120	Ω
Electrical input rise time (20 - 80%)	t_{RE}		160	ps
Electrical input fall time (20 - 80%)	t_{FE}		160	ps

1. The output optical power is compliant with IEC 60825-1 Amendment 2, Class 1M Accessible Emission Limits.

2. The extinction ratio is measured at 622 Mbps.

3. Informative. Corresponds to $P_{\text{OUT}} = -7.5$ dBm and ER = 7 dB.

4. Spectral width is measured as defined in EIA/TIA-455-127 *Spectral Characterization of Multimode Laser Diodes*.

5. Total jitter equals TP1 to TP2 as defined in IEEE 802.3 clauses 38.2 and 38.6 (Gigabit Ethernet).

6. Channel skew is defined for the condition of equal amplitude, zero ps skew signals applied to the transmitter inputs.

7. Differential input voltage is defined as the peak to peak value of the differential voltage between DIN+ and DIN-. Data inputs are CML compatible.

8. Differential input impedance is measured between DIN+ and DIN-.

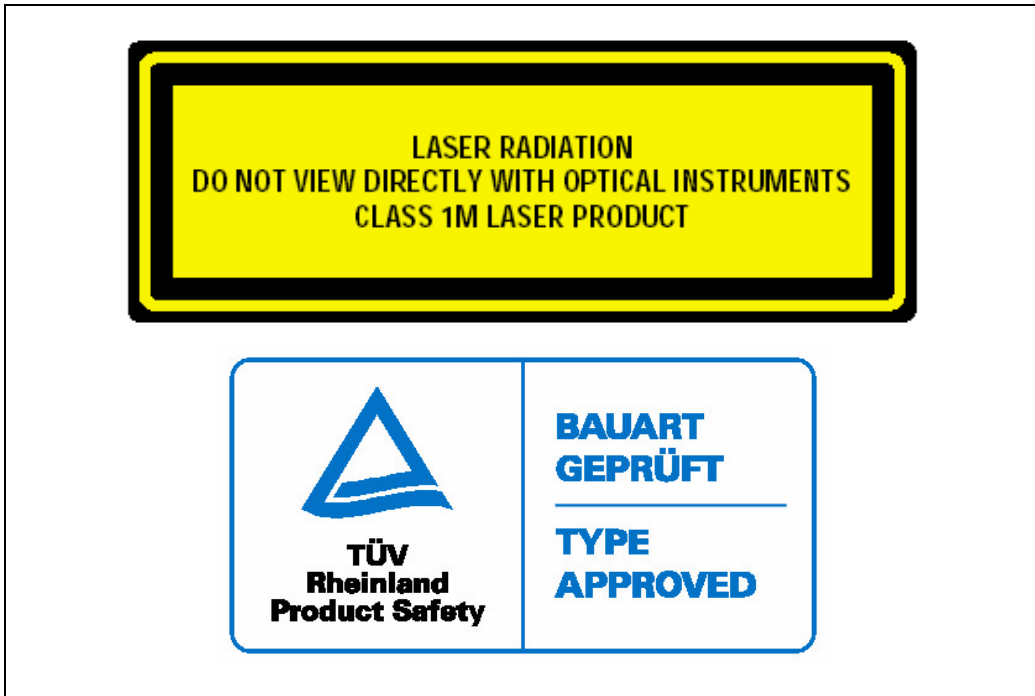

Classified in accordance with IEC 60825-1/A2:2001, IEC 60825-2 : 2000

Class 1M Laser Product

Emitted wavelength: 840 nm

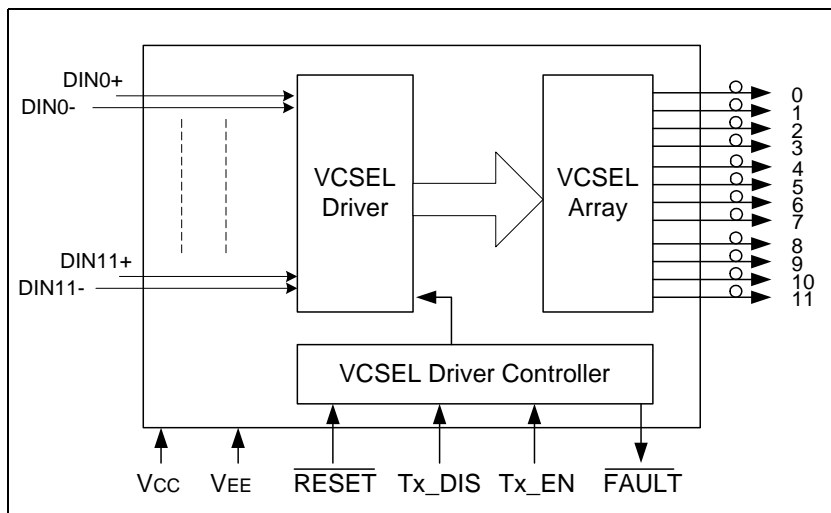

Figure 2 - ZL60101 Transmitter Block Diagram

Front view - MTP key up											
Ch 11	Ch 10	Ch 9	Ch 8	Ch 7	Ch 6	Ch 5	Ch 4	Ch 3	Ch 2	Ch 1	Ch 0
Host circuit board											

Table 1 - Transmitter Optical Channel Assignment

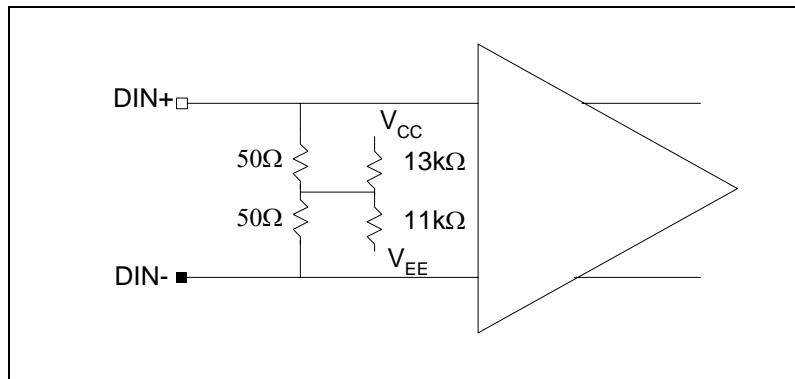

Figure 3 - Differential CML Input Equivalent Circuit

Transmitter Control and Status Signals

The following table shows the timing relationships of the status and control signals of the pluggable optical transmitter.

Parameter	Symbol	Min.	Typ.	Max.	Unit
Control input voltage high ¹	V_{IH}	2.1			V
Control input voltage low	V_{IL}			0.62	V
Control pull-up resistor ²	R_{PU}		10		k Ω
Control pull-down resistor ³	R_{PD1}		10		k Ω
Status output voltage low ^{4, 5}	V_{OL}			0.4	V
Status pull-down resistor ⁴	R_{PD2}		10		k Ω
$\overline{\text{FAULT}}$ assert time	T_{FA}			100	μs
$\overline{\text{FAULT}}$ lasers off	T_{FD}			100	μs
$\overline{\text{RESET}}$ duration	T_{TDD}	10			μs
$\overline{\text{RESET}}$ assert time	T_{OFF}		5	10	μs
$\overline{\text{RESET}}$ de-assert time	T_{ON}			100	ms
Tx_EN assert time	T_{TEN}			1	ms
Tx_EN de-assert time	T_{TD}		5	10	μs
Tx_DIS assert time	T_{TD}		5	10	μs
Tx_DIS de-assert time	T_{TEN}			1	ms

1. Applies to control signals $\overline{\text{RESET}}$, Tx_DIS and Tx_EN.
2. Applies to control signals $\overline{\text{RESET}}$ and Tx_EN. Internal pull-up resistor.
3. Applies to control signal Tx_DIS. Internal pull-down resistor.
4. Applies to status signal $\overline{\text{FAULT}}$. Internal pull-down to V_{EE} .
5. With status output sink current max. 2 mA.

Transmitter Control and Status Timing Diagrams

The following figures show the timing relationships of the status and control signals of the pluggable optical transmitter.

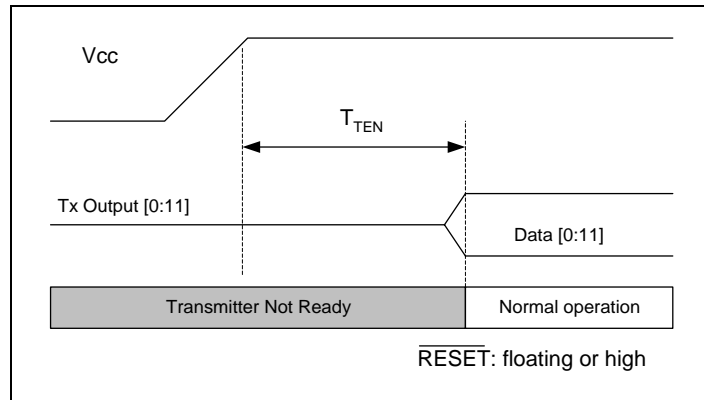

Figure 4 - Transmitter Power-up Sequence

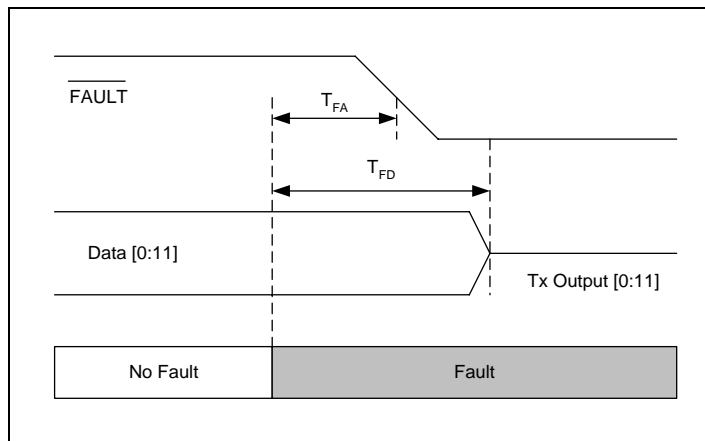

Figure 5 - Transmitter Fault Signal Timing Diagram

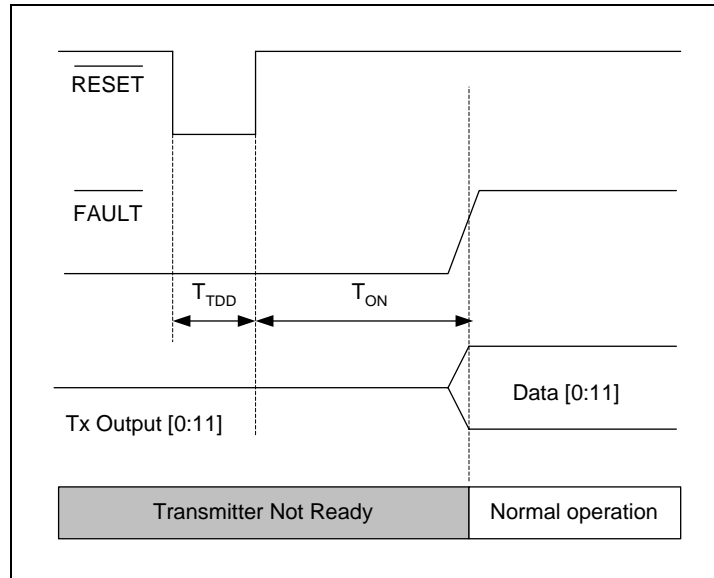

Figure 6 - Transmitter Reset Signal Timing Diagram

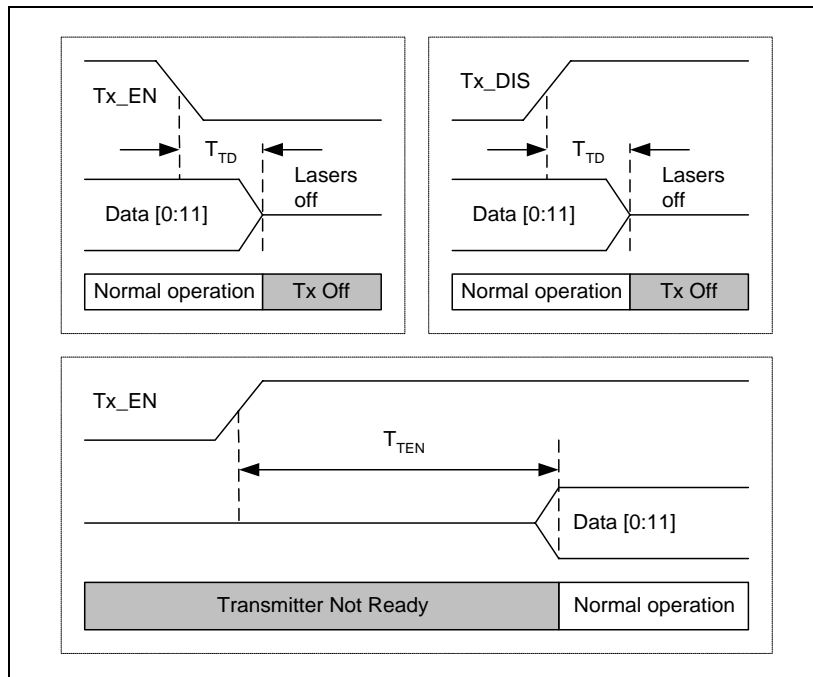

Figure 7 - Transmitter Enable and Disable Timing Diagram

	Tx_DIS High	Tx_DIS Low
Tx_EN High	Transmitter disabled	Normal operation
Tx_EN Low	Transmitter disabled	Transmitter disabled

Table 2 - Truth Table for Transmitter Operation (Pre-condition: $\overline{\text{RESET}}$ floating or HIGH)

Transmitter Pinout Assignments

	K	J	H	G	F	E	D	C	B	A
1	NIC	NIC	NIC	V _{EE}	V _{EE}	V _{EE}	V _{EE}	V _{EE}	V _{EE}	NIC
2	NIC	NIC	NIC	V _{EE}	V _{EE}	DIN5+	V _{EE}	V _{EE}	DIN8+	V _{EE}
3	NIC	V _{CC}	V _{CC}	V _{EE}	DIN4+	DIN5-	V _{EE}	DIN7+	DIN8-	V _{EE}
4	NIC	V _{CC}	V _{CC}	DIN3+	DIN4-	V _{EE}	DIN6+	DIN7-	V _{EE}	NIC
5	NIC	V _{CC}	V _{CC}	DIN3-	V _{EE}	DIN2+	DIN6-	V _{EE}	DIN9-	V _{EE}
6	NIC	V _{CC}	V _{CC}	V _{EE}	DIN1+	DIN2-	V _{EE}	DIN10-	DIN9+	V _{EE}
7	NIC	NIC	NIC	DIN0+	DIN1-	V _{EE}	DIN11-	DIN10+	V _{EE}	NIC
8	DNC	$\overline{\text{RESET}}$	$\overline{\text{FAULT}}$	DIN0-	V _{EE}	V _{EE}	DIN11+	V _{EE}	V _{EE}	NIC
9	DNC	Tx_EN	Tx_DIS	V _{EE}	V _{EE}	V _{EE}	V _{EE}	V _{EE}	V _{EE}	NIC
10	DNC	DNC	DNC	DNC	DNC	DNC	DNC	DNC	DNC	DNC

**Table 3 - Transmitter Host Circuit Board Layout (Top view, toward MPO/MTP™ connector end)
(10x10 array, 1.27 mm pitch)**

Transmitter Pin Description

Signal Name	Type	Description	Comments
DIN[0:11] +/-	Data input	Transmitter data in, channel 0 to 11	Internal differential termination at 100 Ω.
V _{CC}		Transmitter power supply rail	
V _{EE}		Transmitter signal common. All transmitter voltages are referenced to this potential unless otherwise stated.	Directly connect these pads to the PC board transmitter signal ground plane.
Tx_EN	Control input	Transmitter enable. HIGH: normal operation LOW: disable transmitter	Active high, internal pull-up. See Table 2.
Tx_DIS	Control input	Transmitter disable. HIGH: disable transmitter LOW: normal operation	Active high, internal pull-down. See Table 2.
$\overline{\text{FAULT}}$	Status output	Transmitter fault. HIGH: normal operation LOW: laser fault detected on at least one channel	When active, all channels are disabled. Clear by reset signal. Internal pull-up.
$\overline{\text{RESET}}$	Control input	Transmitter reset. HIGH: normal operation LOW: reset to clear fault signal	Internal pull-up.
DNC		Do not connect to any potential, including ground.	
NIC		No internal connection.	

ZL60102 Receiver Specifications

All parameters below require operating conditions according to Table 2 and a termination load of 100 Ω differential at the electrical output.

Parameter	Symbol	Min.	Max.	Unit
<i>Optical Parameters</i>				
Input optical power ¹	P_{IN}	-16	-2	dBm
Center wavelength	λ_C	830	860	nm
Return loss ²	RL	12		dB
Total jitter contributed (peak to peak) ³	TJ		120	ps
Deterministic jitter contributed (peak to peak)	DJ		50	ps
Stressed receiver sensitivity ⁴	P_{SS}		-11.3	dBm
Channel to channel skew ⁵	t_{SK}		100	ps
Signal detect assert	P_{SA}		-17	dBm
Signal detect de-assert	P_{SD}	-27		dBm
<i>Electrical Parameters</i>				
Power dissipation	P_D		1.5	W
Supply current	I_{CC}		450	mA
Differential output voltage amplitude (peak to peak) ⁶	ΔV_{OUT}	500	800	mV _{p-p}
Output differential load impedance ⁷	Z_L	80	120	Ω
Stressed receiver eye opening ⁸	P_{SE}	0.3		UI
Electrical output rise time (20 - 80 %)	t_{RE}		150	ps
Electrical output fall time (20 - 80 %)	t_{FE}		150	ps

1. Receive power for a channel is measured for a BER of 10^{-12} and worst case extinction ratio. P_{IN} (Min) is measured using a fast rise/fall time source with low RIN and adjacent channel(s) operating with incident power of 6 dB above P_{IN} (Min).

2. Return loss is measured as defined in TIA/EIA-455-107A *Determination of Component Reflectance or Link/System Return Loss Using a Loss Test Set*.

3. Total jitter equals TP3 to TP4 as defined in IEEE 802.3 clauses 38.2 and 38.6 (Gigabit Ethernet).

4. The stressed receiver sensitivity is measured using PRBS 2²³-1 pattern, 2.7 dB inter-symbol interference, ISI (Min), 30 ps duty cycle dependent deterministic jitter, DCD DJ (Min), and 7 dB extinction ratio, ER (Min) (ER penalty = 1.76 dB). All channels not under test are receiving signals with an average input power of 6 dB above P_{IN} (Min).

5. Channel skew is defined for the condition of equal amplitude, zero ps skew signals applied to the receiver inputs.

6. Differential output voltage is defined as the peak to peak value of the differential voltage between DOUT+ and DOUT- and measured with a 100 Ω differential load connected between DOUT+ and DOUT-. Data outputs are CML compatible.

7. See Figure 14.

8. The stressed receiver eye opening represents the eye at TP4 as defined in IEEE 802.3 clauses 38.2 and 38.6 (Gigabit Ethernet). The stressed receiver eye opening is measured using PRBS 2²³-1 pattern, 2.7 dB ISI min, 30 ps DCD DJ min, 7 dB ER min and an average input power of -10.8 dBm (0.5 dB above minimum stressed receiver sensitivity as defined in IEEE 802.3 clause 38.6). All channels not under test are receiving signals with an average input power of 6 dB above P_{IN} (Min).

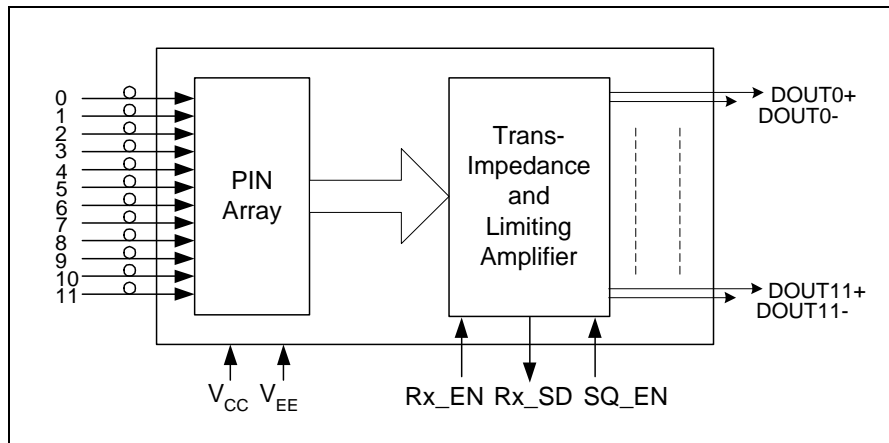

Figure 8 - ZL60102 Receiver Block Diagram

Front view - MTP key up											
Ch 11	Ch 10	Ch 9	Ch 8	Ch 7	Ch 6	Ch 5	Ch 4	Ch 3	Ch 2	Ch 1	Ch 0
Host circuit board											

Table 4 - Receiver Optical Channel Assignment

Receiver Control and Status Signals

The following table shows the timing relationships of the status and control signals of the pluggable optical receiver.

Parameter	Symbol	Min.	Typ.	Max.	Unit
Control input voltage high ¹	V_{IH}	2.0			V
Control input voltage low ¹	V_{IL}			0.9	V
Control input pull-up current ¹	$ I_{IN} $	10		100	μA
Status output voltage low ^{2, 3}	V_{OL}			0.4	V
Status output pull-up resistor ²	R_{PU}		3.25		$k\Omega$
Receiver signal detect assert time	T_{SD}		50	200	μs
Receiver signal detect de-assert time	T_{LOS}		50	200	μs
Receiver enable assert time	T_{RXEN}		33		ms
Receiver enable de-assert time	T_{RXD}		5		μs

1. Applies to control signals Rx_EN, SQ_EN.
 2. Applies to status signal Rx_SD. Internal pull-up to VCC.
 3. With status output sink current max 2 mA.

Receiver Control and Status Timing Diagrams

The following figures show the timing relationships of the status and control signals of the pluggable optical receiver.

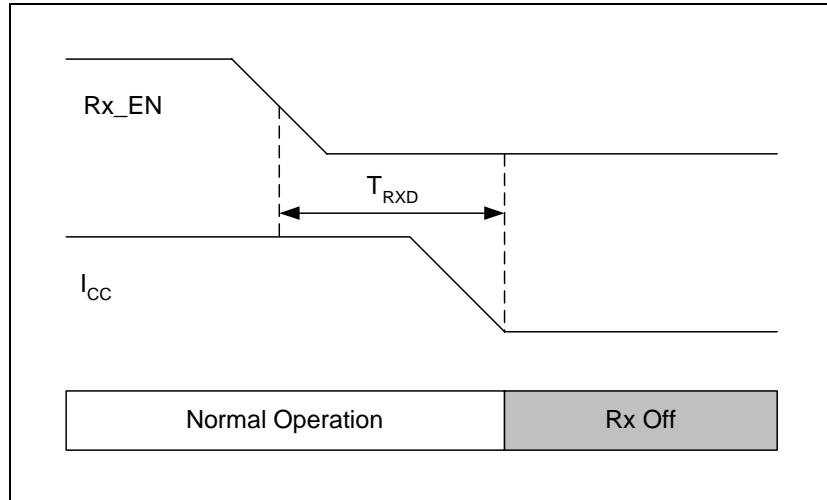

Figure 9 - Receiver Enable Signal Timing Diagram

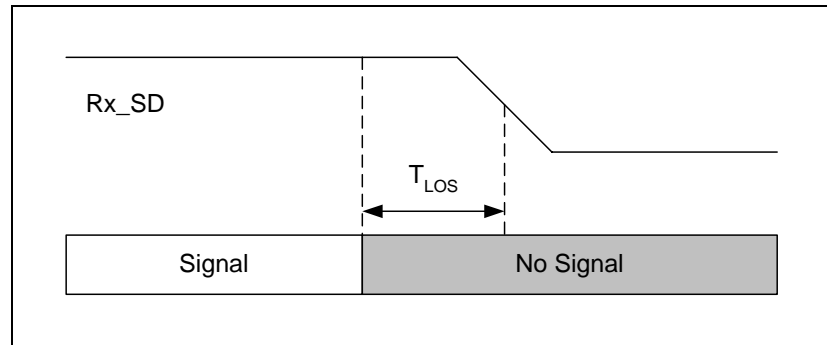

Figure 10 - Receiver Signal Detect Timing Diagram

Receiver Pinout Assignments

	K	J	H	G	F	E	D	C	B	A
1	DNC	NIC	NIC	V _{EE}	V _{EE}	V _{EE}	V _{EE}	V _{EE}	V _{EE}	NIC
2	DNC	NIC	NIC	V _{EE}	V _{EE}	DOUT5-	V _{EE}	V _{EE}	DOUT8-	V _{EE}
3	NIC	V _{CC}	V _{CC}	V _{EE}	DOUT4-	DOUT5+	V _{EE}	DOUT7-	DOUT8+	V _{EE}
4	NIC	V _{CC}	V _{CC}	DOUT3-	DOUT4+	V _{EE}	DOUT6-	DOUT7+	V _{EE}	NIC
5	NIC	V _{CC}	V _{CC}	DOUT3+	V _{EE}	DOUT2-	DOUT6+	V _{EE}	DOUT9+	V _{EE}
6	NIC	V _{CC}	V _{CC}	V _{EE}	DOUT1-	DOUT2+	V _{EE}	DOUT10+	DOUT9-	V _{EE}
7	NIC	NIC	Rx_SD	DOUT0-	DOUT1+	V _{EE}	DOUT11+	DOUT10-	V _{EE}	NIC
8	DNC	NIC	NIC	DOUT0+	V _{EE}	V _{EE}	DOUT11-	V _{EE}	V _{EE}	NIC
9	DNC	Rx_EN	NIC	V _{EE}	V _{EE}	V _{EE}	V _{EE}	V _{EE}	V _{EE}	NIC
10	SQ_EN	DNC	DNC	DNC	DNC	DNC	DNC	DNC	DNC	DNC

**Table 5 - Receiver Pinout Assignments (Top view, toward MPO/MTP™ connector end)
(10x10 array, 1.27 mm pitch)**

Receiver Pin Description

Signal Name	Type	Description	Comments
DOUT[0:11] +/-	Data output	Receiver data out, channel 0 to 11.	
V _{CC}		Receiver power supply rail.	
V _{EE}		Receiver signal common. All receiver voltages are referenced to this potential unless otherwise stated.	Directly connect these pads to the PC board transmitter signal ground plane.
Rx_EN	Control input	Receiver enable. HIGH: normal operation LOW: disable receiver	Internal pull-up.
Rx_SD	Status output	Receiver signal detect. HIGH: valid optical input on all channels LOW: loss of signal on at least one channel	Internal pull-up.
SQ_EN	Control input	Squelch enable. HIGH: squelch function enabled. Data OUT is squelched on any channels that have loss of signal LOW: squelch function disabled	Internal pull-up.
DNC		Do not connect to any potential, including ground.	
NIC		No internal connection.	

Thermal Characteristics

There are three options for heat sinks depending on the cooling needs. They are:

1. Direct application without any attached external heat sink
2. Use a generic heat sink specified by Zarlink
3. Use a customer designed external heat sink

In Figure 11 and Figure 12, the temperature rise and thermal resistance as a function of air velocity (free air velocity at the top of the module) is shown for option 1 and 2. The thermal resistance is defined as the temperature difference between the case temperature and ambient flowing air divided by the total heat dissipation of the module.

Improved thermal properties can be achieved by using a larger heat sink especially if more height is available (option 3). For this option, a more detailed discussion with Zarlink is recommended regarding heat sink design attachment materials.

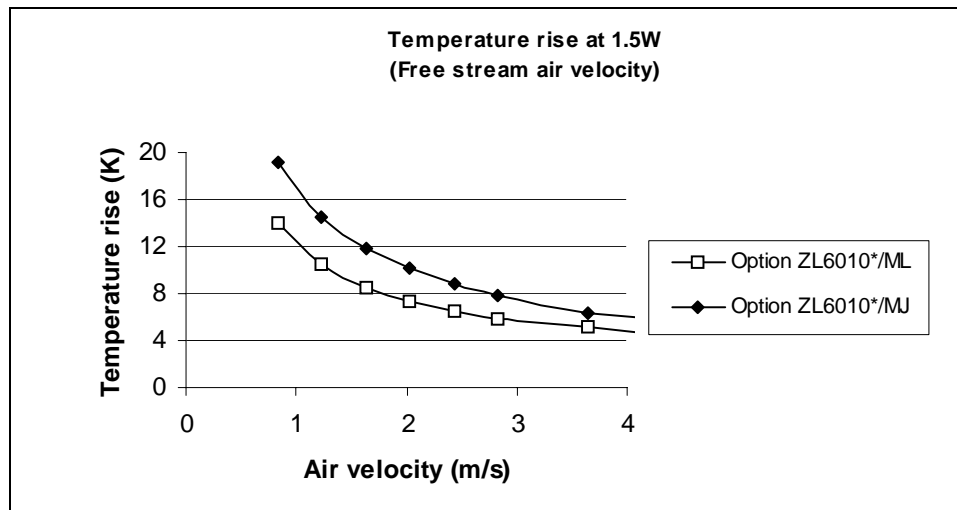

Figure 11 - Temperature Difference Between Ambient Flowing Air and Case at a Heat Dissipation of 1.5 W

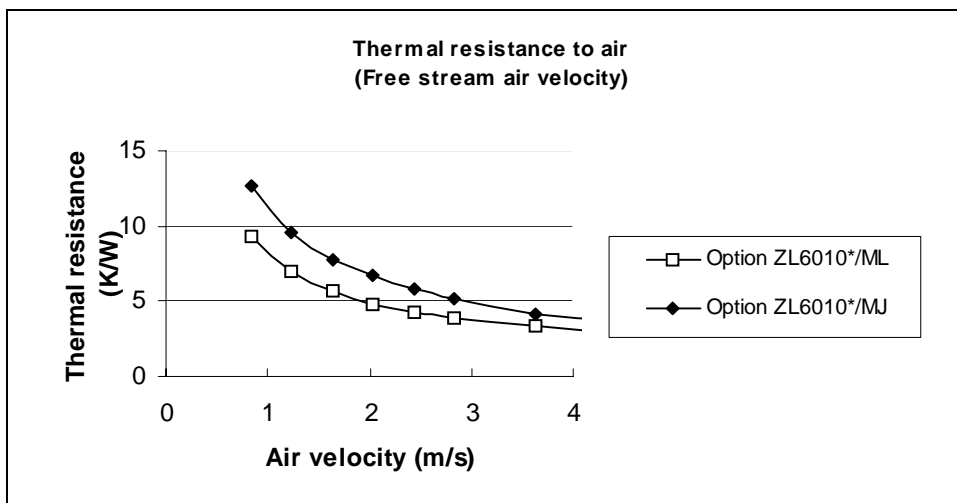

Figure 12 - Thermal Resistance, as a Function of Air Velocity (the airflow is along the shortest side of the module)

For any other orientation, the thermal resistance is 75-100% of the values shown above.

Regulatory Compliance

Eye Safety

The maximum optical output power is specified to comply with Class 1M in accordance with IEC 60825-1:2001. In addition the transmitter complies with FDA performance standards for laser products except for deviations pursuant to Laser Notice No.50, dated July 26, 2001. No maintenance or service of the product may be performed.

Electrostatic Discharge

The module is classified as Class 1 (> 1000 Volts) according to MIL-STD-883, test method 3015.7, with regards to the electrical pads.

Electrostatic Discharge Immunity

The part withstand a 15 kV (air discharge) and 8 kV (contact discharge) either indirect or directly to receptacle; tested according to IEC 61000-4-2, while in operation without addition of bit errors.

Electromagnetic Interference

Emission

The electromagnetic emission is tested in front of the module (module fitted with EMI shield), with the module mounted in a frontplate cutout. The part is tested with FCC Part 15, 30 – 1000 MHz and 1 GHz to 5th harmonic of the highest fundamental frequency (6.75 GHz), and is specified to be Class B with > 6 dB margin.

Immunity

The electromagnetic immunity is tested without a front panel or enclosure. The module specification is maintained with an applied field of 10 V/m for frequencies between 10 kHz and 10 GHz, according to IEC 61000-4-3 and GR-1089-CORE.

Handling instructions

Cleaning the Optical Interface

A protective connector plug is supplied with each module. This plug should remain in place whenever a fiber cable is not inserted. This will keep the optical port free from dust or other contaminants, which may potentially degrade the optical signal. Before reattaching the connector plug to the module, visually inspect the plug and remove any contamination. If the module's optical port becomes contaminated, it can be cleaned with high-pressure nitrogen (the use of fluids, or physical contact, is not advised due to potential for damage).

Before a fiber cable connector is attached to the module, it is recommended to clean the fiber cable connector using an optical connector cleaner, or according to the cable manufacturer's instructions. It is also recommended to clean the optical port of the module with high-pressure nitrogen.

Connectors

For optimum performance, it is recommended that the number of insertions is limited to 50 for the electrical MegArray connector and 200 for the optical MPO/MTP connector.

ESD Handling

When handling the modules, precautions for ESD sensitive devices should be taken. These include use of ESD protected work areas with wrist straps, controlled work-benches, floors etc.

Link Reach

The following table lists the minimum reach distance of the 12 channel pluggable optical modules for different multi-mode fiber (MMF) types and bandwidths assuming worst case parameters. Each case allows for a maximum of 2 dB per channel connection loss for patch cables and other connectors.

Fiber Type [core / cladding μm]	Modal Bandwidth @ 850 nm [MHz*km]	Reach Distance @ 1 Gbps [m]	Reach Distance @ 2.5 Gbps [m]	Reach Distance @ 2.72 Gbps [m]
62.5/125 MMF	200	350	130	110
62.5/125 or 50/125 MMF	400	650	260	220
50/125 MMF	500	750	300	270

Table 6 - Link Reach for Different Fiber Types and Data Rates

Link Model Parameters

The link reaches above have been calculated using the following link model parameters and Gigabit Ethernet link model version 2.3.5 (filename: 5pmd047.xls).

Parameter	Symbol	Value	Unit
Mode partition noise k-factor	k	0.3	
Modal noise	MN	0.3	dB
Dispersion slope parameter	S_O	0.11	ps/nm ² *km
Wavelength of zero dispersion	U_O	1320	nm
Attenuation coefficient at 850 nm	α_{dB}	3.5	dB/km
Conversion factor	C1	480	ns.MHz
Q-factor [BER 10 ⁻¹²]	Q	7.04	
TP4 eye opening		0.3	UI
DCD allocation at TP3	DCD DJ	0.08	UI
RMS baseline wander S.D.	σ_{BLW}	0.025	
RIN coefficient	k_{RIN}	0.70	
Conversion factor	c_{rx}	329	ns.MHz

Electrical Interface - Application Examples

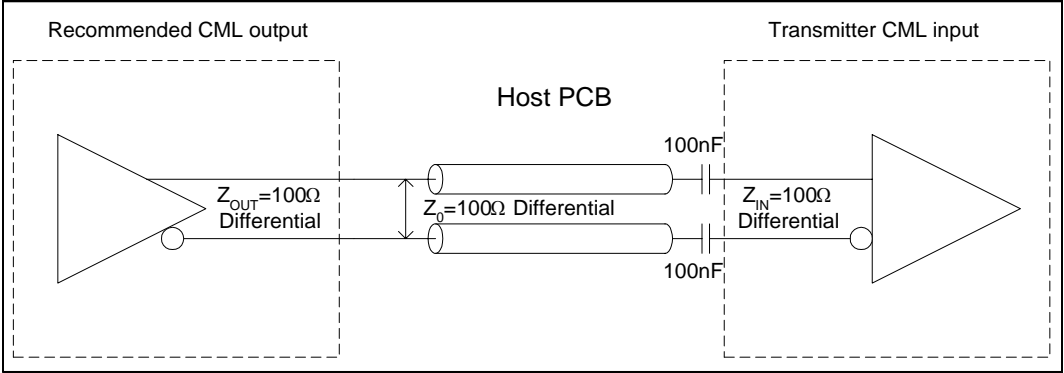

Figure 13 - Recommended Differential CML Input Interface

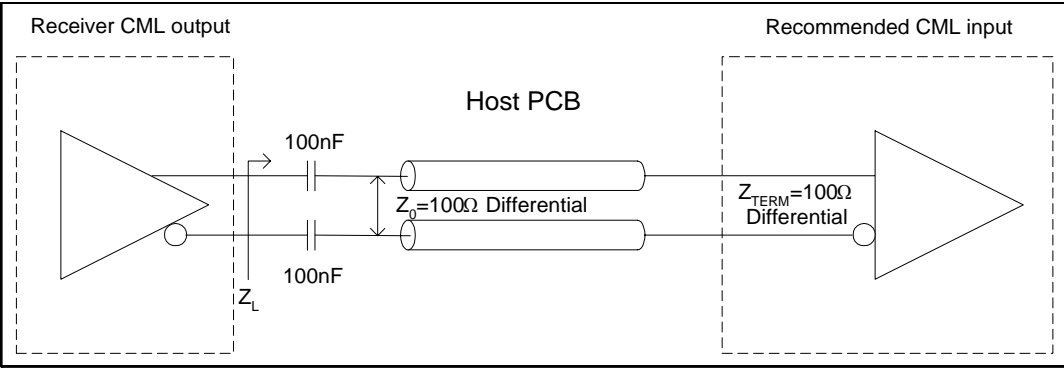
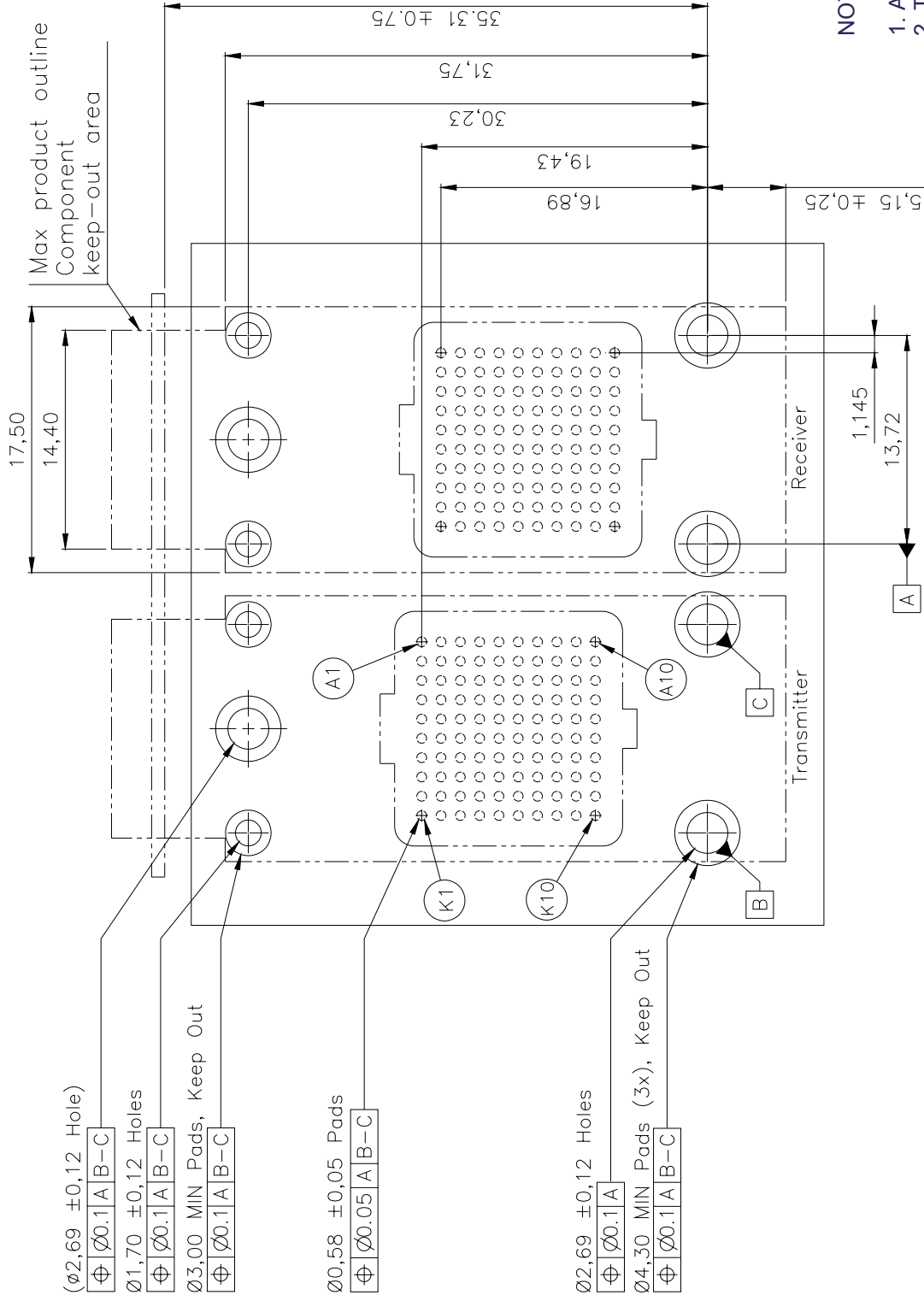

Figure 14 - Recommended Differential CML Output Interface



NOTES:-

1. All dimensions in mm.
2. Tolerancing per ASME Y14.5M-1994.

Zarlink Semiconductor 2002. All rights reserved.

JE	1		
N	JS004293R1A		
E	12-JUN-03		
PRD.	TD/BE		



Previous package codes

Package code **MJD**

Drawing type
Package Drawing,
Host circuit board footprint layout

Title **JS004293**



**For more information about all Zarlink products
visit our Web Site at
www.zarlink.com**

Information relating to products and services furnished herein by Zarlink Semiconductor Inc. or its subsidiaries (collectively "Zarlink") is believed to be reliable. However, Zarlink assumes no liability for errors that may appear in this publication, or for liability otherwise arising from the application or use of any such information, product or service or for any infringement of patents or other intellectual property rights owned by third parties which may result from such application or use. Neither the supply of such information or purchase of product or service conveys any license, either express or implied, under patents or other intellectual property rights owned by Zarlink or licensed from third parties by Zarlink, whatsoever. Purchasers of products are also hereby notified that the use of product in certain ways or in combination with Zarlink, or non-Zarlink furnished goods or services may infringe patents or other intellectual property rights owned by Zarlink.

This publication is issued to provide information only and (unless agreed by Zarlink in writing) may not be used, applied or reproduced for any purpose nor form part of any order or contract nor to be regarded as a representation relating to the products or services concerned. The products, their specifications, services and other information appearing in this publication are subject to change by Zarlink without notice. No warranty or guarantee express or implied is made regarding the capability, performance or suitability of any product or service. Information concerning possible methods of use is provided as a guide only and does not constitute any guarantee that such methods of use will be satisfactory in a specific piece of equipment. It is the user's responsibility to fully determine the performance and suitability of any equipment using such information and to ensure that any publication or data used is up to date and has not been superseded. Manufacturing does not necessarily include testing of all functions or parameters. These products are not suitable for use in any medical products whose failure to perform may result in significant injury or death to the user. All products and materials are sold and services provided subject to Zarlink's conditions of sale which are available on request.

Purchase of Zarlink's I²C components conveys a licence under the Philips I²C Patent rights to use these components in and I²C System, provided that the system conforms to the I²C Standard Specification as defined by Philips.

Zarlink, ZL and the Zarlink Semiconductor logo are trademarks of Zarlink Semiconductor Inc.

Copyright Zarlink Semiconductor Inc. All Rights Reserved.

TECHNICAL DOCUMENTATION - NOT FOR RESALE
