

查询ZUMT2222A供应商

捷多邦, 专业PCB打样工厂

, 24小时加急出货

SOT323 NPN SILICON PLANAR SWITCHING TRANSISTOR

ZUMT2222A

ISSUE 1 – NOVEMBER 1998

FEATURES

* Fast switching

PARTMARKING DETAIL – T16

COMPLEMENTARY TYPE – ZUMT2907A

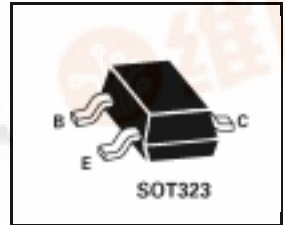

ABSOLUTE MAXIMUM RATINGS.

PARAMETER	SYMBOL	VALUE	UNIT
Collector-Base Voltage	V_{CBO}	75	V
Collector-Emitter Voltage	V_{CEO}	40	V
Emitter-Base Voltage	V_{EBO}	6	V
Continuous Collector Current	I_C	600	mA
Power Dissipation at $T_{amb}=25^{\circ}C$	P_{tot}	330	mW
Operating and Storage Temperature Range	$T_j; T_{stg}$	-55 to +150	$^{\circ}C$

ELECTRICAL CHARACTERISTICS (at $T_{amb} = 25^{\circ}C$ unless otherwise stated).

PARAMETER	SYMBOL	MIN.	MAX.	UNIT	CONDITIONS.
Collector-Base Breakdown Voltage	$V_{(BR)CBO}$	75		V	$I_C=10\mu A, I_E=0$
Collector-Emitter Breakdown Voltage	$V_{(BR)CEO}$	40		V	$I_C=10mA, I_B=0$
Emitter-Base Breakdown Voltage	$V_{(BR)EBO}$	6		V	$I_E=10\mu A, I_C=0$
Collector Cut-Off Current	I_{CBO}		10 10	nA μA	$V_{CB}=60V, I_E=0$ $V_{CB}=60V, I_E=0, T_{amb}=150^{\circ}C$
Emitter Cut-Off Current	I_{EBO}		10	nA	$V_{EB}=3V, I_C=0$
Collector-Emitter Cut-Off Current	I_{CEX}		10	nA	$V_{CE}=60V, V_{EB(off)}=3V$
Collector-Emitter Saturation Voltage	$V_{CE(sat)}$		0.3 1.0	V V	$I_C=150mA, I_B=15mA^*$ $I_C=500mA, I_B=50mA^*$
Base-Emitter Saturation Voltage	$V_{BE(sat)}$	0.6	1.2 2.0	V V	$I_C=150mA, I_B=15mA^*$ $I_C=500mA, I_B=50mA^*$
Static Forward Current Transfer Ratio	h_{FE}	35 50 75 35 100 50 40	300		$I_C=0.1mA, V_{CE}=10V^*$ $I_C=1mA, V_{CE}=10V$ $I_C=10mA, V_{CE}=10V^*$ $I_C=10mA, V_{CE}=10V, T_{amb}=-55^{\circ}C$ $I_C=150mA, V_{CE}=10V^*$ $I_C=150mA, V_{CE}=1V^*$ $I_C=500mA, V_{CE}=10V^*$

* Measured under pulsed conditions. Pulse width=300 μs . Duty cycle $\leq 2\%$
Spice parameter data is available upon request for this device



ZUMT2222A

ELECTRICAL CHARACTERISTICS (at $T_{amb} = 25^{\circ}\text{C}$ unless otherwise stated).

PARAMETER	SYMBOL	MIN.	MAX.	UNIT	CONDITIONS.
Transition Frequency	f_T	300		MHz	$I_C=20\text{mA}$, $V_{CE}=20\text{V}$ $f=100\text{MHz}$
Output Capacitance	C_{obo}		8	pF	$V_{CE}=10\text{V}$, $I_E=0$, $f=140\text{KHz}$
Input Capacitance	C_{ibo}		25	pF	$V_{EB}=0.5\text{V}$, $I_C=0$ $f=140\text{KHz}$
Delay Time	t_d		10	ns	$V_{CC}=30\text{V}$, $V_{BE(off)}=0.5\text{V}$ $I_C=150\text{mA}$, $I_{B1}=15\text{mA}$ (See Delay Test Circuit)
Rise Time	t_r		25	ns	
Storage Time	t_s		225	ns	$V_{CC}=30\text{V}$, $I_C=150\text{mA}$ $I_{B1}=I_{B2}=15\text{mA}$ (See Storage Test Circuit)
Fall Time	t_f		60	ns	

DELAY AND RISE – TEST CIRCUIT

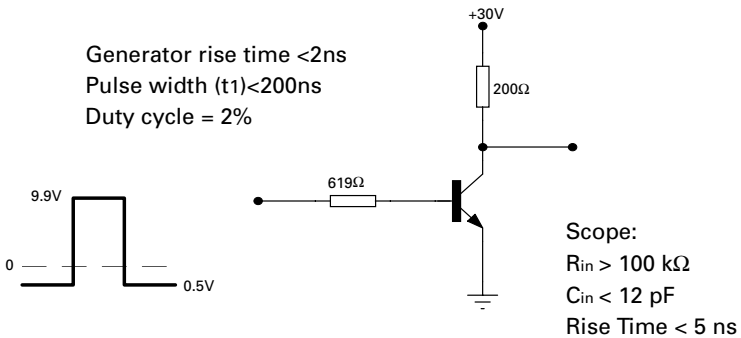

STORAGE TIME AND FALL TIME – TEST CIRCUIT

