

ZXBM2004

VARIABLE SPEED 2-PHASE BLDC MOTOR CONTROLLER

DESCRIPTION

The ZXBM2004 is a 2-phase, DC brushless motor pre-driver with PWM variable speed control suitable for fan and blower motors. The controller is intended for applications where the fan or blower speed is controlled by an external PWM signal, thermistor or DC voltage.

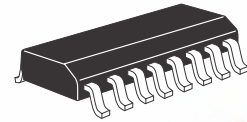

QSOP16

FEATURES

- Compliant with external PWM speed control
- Compliant with thermistor control
- Minimum speed setting
- Low noise
- Auto restart
- Built in hall amplifier
- Speed pulse (FG) and lock rotor (RD) outputs
- Up to 18V input voltage (60V with external regulator)
- QSOP16 package
- Lead free product

Associated application notes:-

AN41 - Thermistor control

AN42 - External PWM control

AN43 - Interfacing to the motor windings

APPLICATIONS

- Mainframe and personal computer fans and blowers
- Instrumentation fans
- Central heating blowers
- Automotive climate control

ORDERING INFORMATION - QSOP16

DEVICE	REEL SIZE	TAPE WIDTH	QUANTITY PER REEL
ZXBM2004Q16TC	13" (330mm)	12mm	2,500

DEVICE MARKING

- ZETEX
ZXBM
2004

ZXBM2004

ABSOLUTE MAXIMUM RATINGS

PARAMETER	SYMBOL	LIMITS	UNIT
Supply voltage	V_{CCmax}	-0.6 to 20	V
Input current	I_{CCmax}	100	mA
Input voltage	$V_{IN max}$	-0.5 to $V_{CC} + 0.5$	V
Output voltage	$V_{OUT max}$	-0.5 to $V_{CC} + 0.5$	V
Power dissipation	P_{Dmax}	500	mW
Operating temp.	T_{OPR}	-40 to 110	°C
Storage temp.	T_{STG}	-55 to 125	°C

Power Dissipation

1) Maximum allowable Power Dissipation, P_D , is shown plotted against Ambient Temperature, T_A , in the accompanying Power Derating Curve, indicating the Safe Operating Area for the device.

2) Power consumed by the device, P_T , can be calculated from the equation:

$$P_T = P_Q + P_{Ph}$$

where P_Q is power dissipated under quiescent current conditions, given by:

$$P_Q = V_{CC} \times I_{CC}$$

where V_{CC} is the application device Supply Voltage

and I_{CC} is the maximum Supply Current given in the Electrical Characteristics

and P_{Ph} is power generated due to either one of the phase outputs Ph1 or Ph2 being active, given by:

$$P_{Ph} = I_{OL} \times V_{OL}$$

where I_{OL} is the application Ph1 and Ph2 output currents

and V_{OL} is the maximum Low Level Output Voltage for the Ph1 and Ph2 outputs given in the Electrical Characteristics

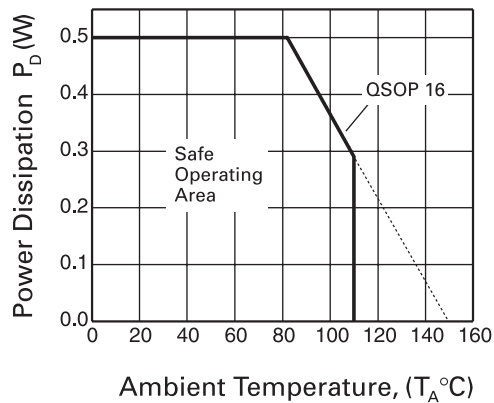

ZXBM2004 Power Derating Curve

$\theta_{j-a} = 112^\circ\text{C/W}$

ZXBM2004

ELECTRICAL CHARACTERISTICS (at Tamb = 25°C & Vcc = 12V)

PARAMETER	SYMBOL	MIN	TYP	MAX	UNIT	CONDITIONS
Supply Voltage	V _{CC}	4.7		18	V	
Supply Current	I _{CC}		5.5	7.5	mA	No Load ¹
Hall Amp Input Voltage	V _{IN}	40			mV	diff p-p
Hall Amp Common Mode Voltage	V _{CM}	0.5		V _{CC} -1.5	V	
Hall Amp Input Offset	V _{OFS}		±7		mV	
Hall Amp Bias Current	I _{BS}		-400	-710	nA	
PH1, PH2 Output High	V _{OH}	V _{CC} -2.2	V _{CC} -1.8		V	I _{OH} = -80mA
PH1, PH2 Output Low	V _{OLA}		0.4	0.6	V	I _{OL} = 16mA ²
PH1, PH2 Output Low	V _{OLB}		0.4	0.6	V	I _{OL} = 50µA ³
PH1, PH2 Output Source Current	I _{OH}			-80	mA	
PH1, PH2 Output Sink Current	I _{OL}			16	mA	
C _{PWM} Charge Current	I _{PWMC}	-4.5		-7.85	µA	
C _{PWM} Discharge Current	I _{PWMD}	38		65	µA	
C _{PWM} High Threshold Voltage	V _{THH}		3		V	
C _{PWM} Low Threshold Voltage	V _{THL}		1		V	
PWM Frequency	F _{PWM}		24		kHz	C _{PWM} = 0.1nF
ThRef Voltage	V _{ThRef}	2.88	2.96	3.10	V	I _{OThRef} = -100µA
ThRef Output Current	I _{OThRef}			-1	mA	
S _{MIN} Input Current	I _{ISMIN}		-0.25	-0.3	µA	V _{IN} = 2V, SPD=open
SPD Voltage Minimum	V _{SPDL}		1		V	100% PWM Drive
SPD Voltage Maximum	V _{SPDH}		3		V	0% PWM Drive
SPD Input Current	I _{ISPD}		-0.8	-2	µA	V _{IN} = 2V
C _{LCK} Charge Current	I _{LCKC}	-2.8	-3.8		µA	
C _{LCK} Discharge Current	I _{LCKD}		0.46	0.54	µA	
C _{LCK} High Threshold Voltage	V _{THH}		3		V	
C _{LCK} Low Threshold Voltage	V _{THL}		1		V	
Lock condition On:Off ratio			1:12			
FG & RD Low Level Output Current	I _{OL}			5	mA	
FG & RD Low Level Output Voltage	V _{OL}			0.5	V	I _{OL} = 5mA
Commutation dead time	t _{CD}		7.5		µs	

Notes:

1. Measured with pins H+, H-, CLCK and CPWM = 0V and all other signal pins open circuit.
2. Measured when opposing Phase Output is Low
3. Measured when opposing Phase Output is High
4. In this datasheet a negative sign for a current indicates current flowing out of the pin whilst no sign indicates current flowing into the pin.

ZXBM2004

Block diagram

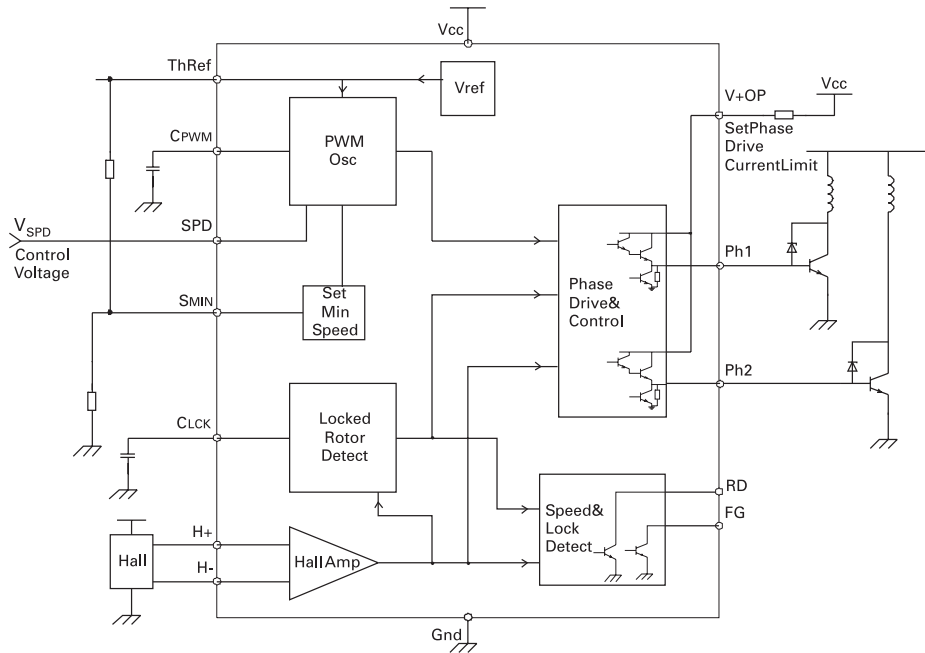

Pin assignments

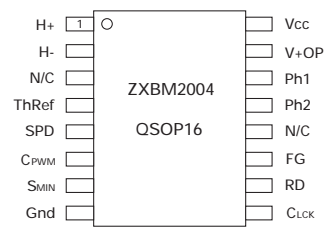

ZXBM2004

PIN FUNCTIONAL DESCRIPTION

H+ - Hall input H- - Hall input

The rotor position is detected by a Hall sensor, with the output applied to the H+ and H- pins. This sensor can be either a 4 pin 'naked' Hall device or of the 3 pin buffered switching type. For a 4 pin device the differential Hall output signal is connected to the H+ and H- pins. For a buffered Hall sensor the Hall device output is attached to the H+ pin, with a pull-up attached if needed, whilst the H- pin has an external potential divider attached to hold the pin at half V_{CC} . When H+ is high in relation to H-, Ph2 is the active drive.

ThRef - Network Reference

This is a reference voltage of nominal 3V. It is designed for the ability to 'source' and therefore it will not 'sink' any current from a higher voltage.

The current drawn from the pin by the minimum speed potential divider to pin S_{MIN} and any voltage setting network should not exceed 1mA in total at maximum temperature.

SPD - Speed Control Input

The voltage applied to the SPD pin provides control over the Fan Motor speed by varying the Pulse Width Modulated (PWM) drive ratio at the Ph1Lo and Ph2Lo outputs. The control signal takes the form of a voltage input of range 3V to 1V, representing 0% to 100% drive respectively.

If variable speed control is not required this pin can be left with an external potential divider to set a fixed speed or tied to ground to provide full speed i.e. 100% PWM drive.

If required this pin can also be used as an enable pin. The application of a voltage $>3.0V$ will force the PWM drive fully off, in effect disabling the drive.

S_{MIN} - Sets Minimum Speed

A voltage can be set on this pin via a potential divider between the ThRef and Gnd. This voltage is monitored by the SPD pin such that it cannot rise above it. As a higher voltage on the SPD pin represents a lower speed it therefore restricts the lower speed range of the fan. If this feature is not required the pin is left tied to ThRef so no minimum speed will be set.

If the fan is being controlled from an external voltage source onto the SPD pin then either this feature should not be used or if it is required then a $>1k\Omega$ resistor should be placed in series with the SPD pin.

C_{PWM} - Sets PWM Frequency

This pin has an external capacitor attached to set the PWM frequency for the Phase drive outputs. A capacitor value of 0.1nF will provide a PWM frequency of typically 24kHz.

The C_{PWM} timing period (T_{PWM}) is determined by the following equation:

$$T_{PWM} = \frac{(V_{THH} - V_{THL}) \times C}{I_{PWMC}} + \frac{(V_{THH} - V_{THL}) \times C}{I_{PWMD}}$$

Where: $C = C_{PWM} + 15$, in pF
 V_{THH} and V_{THL} are the C_{PWM} pin threshold voltages
 I_{PWMC} and I_{PWMD} are the charge and discharge currents in μA .
 T_{PWM} is in ms

ZXBM2004

As these threshold voltages are nominally set to $V_{THH} = 3V$ and $V_{THL} = 1V$ the equations can be simplified as follows:

$$T_{PWM} = \frac{2C}{I_{PWMC}} + \frac{2C}{I_{PWMD}}$$

C_{LCK} - Locked rotor timing capacitor

Should the fan stop rotating for any reason, i.e. an obstruction in the fan blade or a seized bearing, then the device will enter a Rotor Locked condition. In this condition after a predetermined time (T_{LOCK}) the RD pin will go high and the Phase outputs will be disabled. After a further delay (T_{OFF}) the controller will re-enable the Phase drive for a defined period (T_{ON}) in an attempt to re-start the fan. This cycle of (T_{OFF}) and (T_{ON}) will be repeated indefinitely or until the fan re-starts.

GND - Ground

This is the device supply ground return pin and will generally be the most negative supply pin to the fan.

RD - Locked Rotor error output

This pin is the Locked Rotor output as referred to in the C_{LCK} timing section above. It is high when the rotor is stopped and low when it is running.

This is an open collector drive giving an active pull down with the high level being provided by an external pull up resistor.

FG - Frequency Generator (speed) output

This is the Frequency Generator output and is a buffered signal from the Hall sensor.

This is an open collector drive giving an active pull down with the high level being provided by an external pull up resistor.

Ph1Lo & Ph2Lo - Driver

This pair of outputs drive the external devices. These outputs provide both the commutation and PWM waveforms. The outputs are of the Darlington emitter follower type with an active pull-down to help faster switch off when using bipolar devices. When in the high state the outputs will provide up to 80mA of drive into the base or gates of external transistors as shown in the Typical Application circuit following.

When in the low state the active Phase drive is capable of sinking up to 16mA when driving low to aid turn off times during PWM operation. When the Phase is inactive the output is held low by an internal pull-down resistor.

V+OP - Phase Outputs Supply Voltage

This pin is the supply to the Phase outputs and will be connected differently dependant upon external transistor type.

For bipolar devices this pin will be connected by a resistor to the V_{CC} pin. The resistor is used to control the current into the transistor base so its value is chosen accordingly.

For MOSFET devices the pin will connect directly to the V_{CC} pin.

ZXBM2004

V_{CC} - Applied Voltage

This is the device internal circuitry supply voltage. For 5V to 12V fans this can be supplied directly from the Fan Motor supply. For fans likely to run in excess of the 18V maximum rating for the device this will be supplied from an external regulator such as a Zener diode.

RD Timing Waveform:

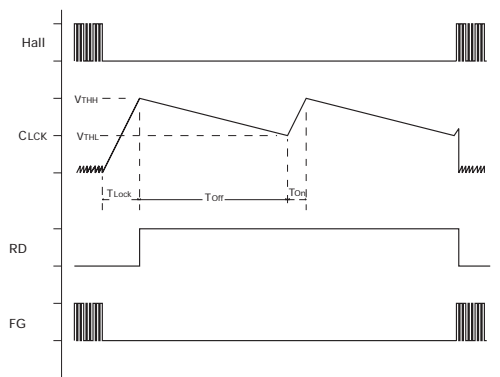

Applications Information

The ZXBM2004 is primarily controlled by a voltage on the SPD pin. A voltage of 1V represents a 100% PWM at the Phase Outputs and in turn represents full speed. 3V on the SPD pin conversely represents 0% PWM. The motor can therefore be controlled simply by applying a control voltage onto the SPD pin with the minimal use of external components.

This voltage control method easily lends itself to control by other signal types. For example if a thermistor is applied to the SPD pin a varying voltage can be generated at the SPD pin as the resistance of the thermistor varies with temperature.

A common form of control of fans is by a PWM signal derived from a central processor or controller. This signal can be converted into a voltage and that voltage adjusted as necessary to compensate for motor non linearity, inclusion of the Minimum speed feature etc.

Full applications details and further examples of how to control the ZXBM2004 are available in the Applications Notes AN41, AN42 and AN43.

ZXBM2004

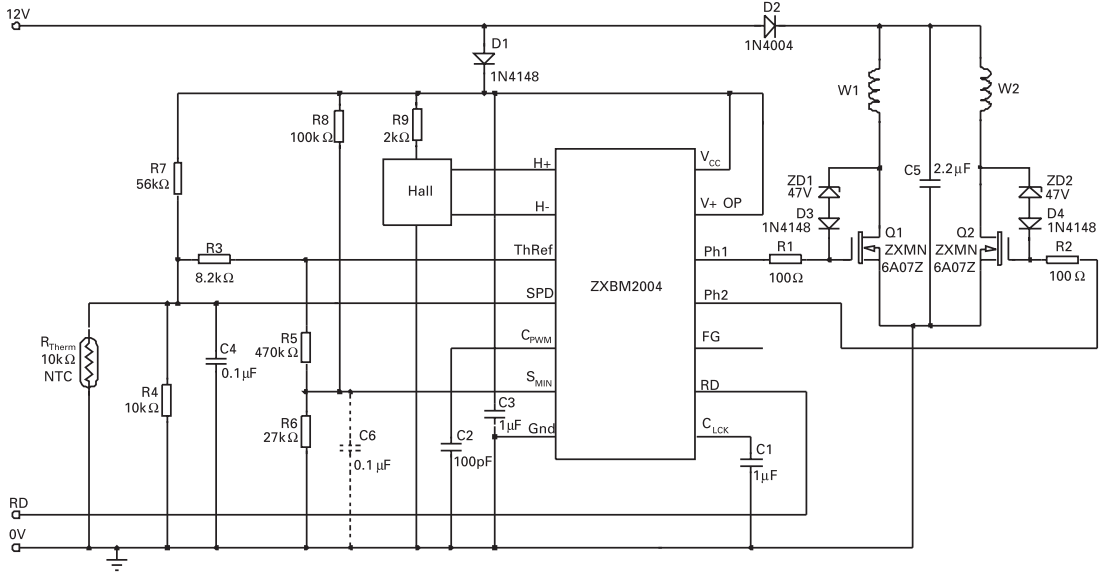

Figure 1: 12V Typical circuit for thermistor controlled speed

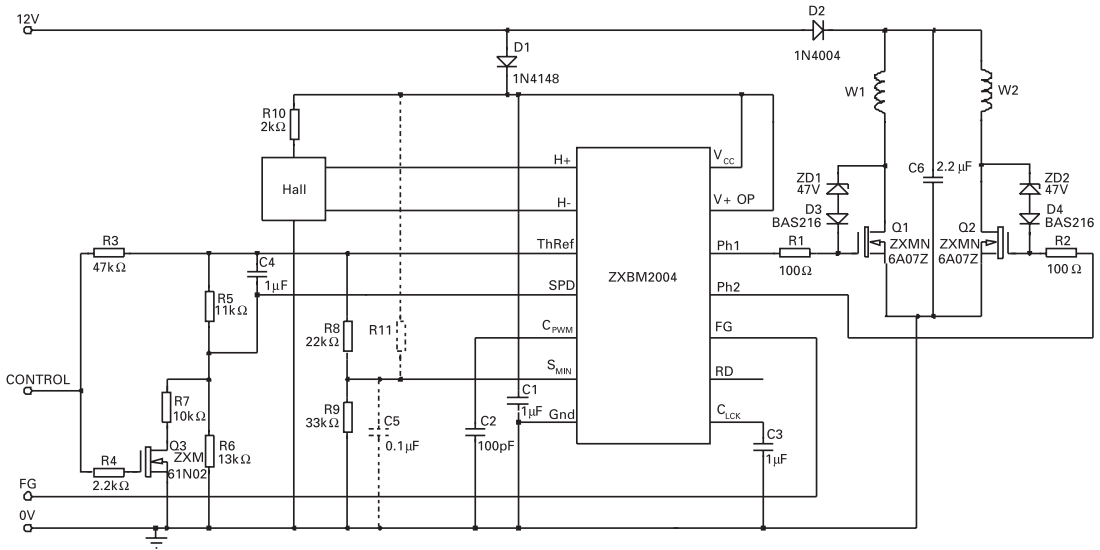

Figure 2: Typical circuit for external PWM controlled speed (single MOSFET)

ZXBM2004

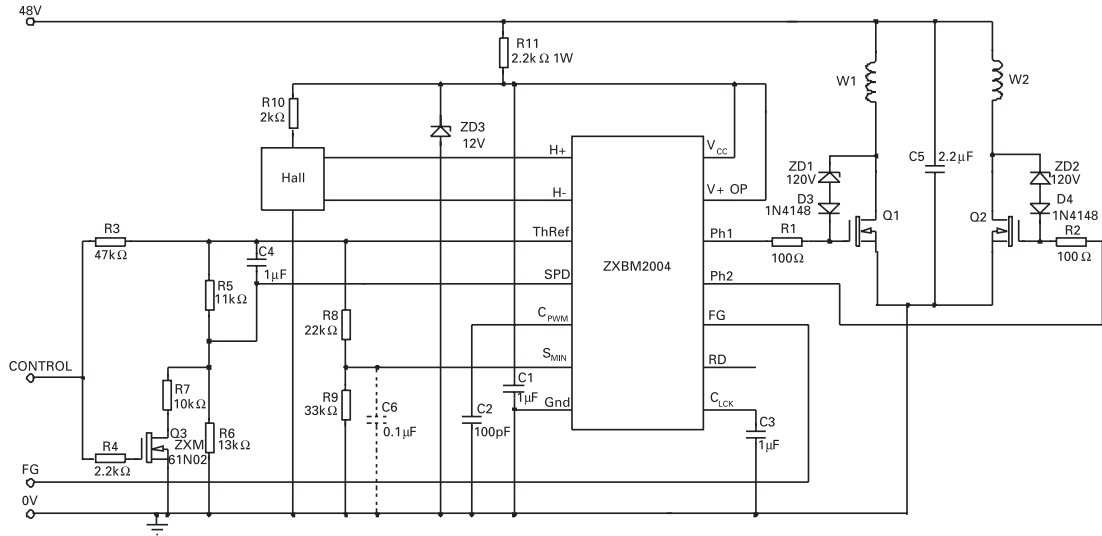

Figure 3: Typical circuit for 48V input and external PWM control

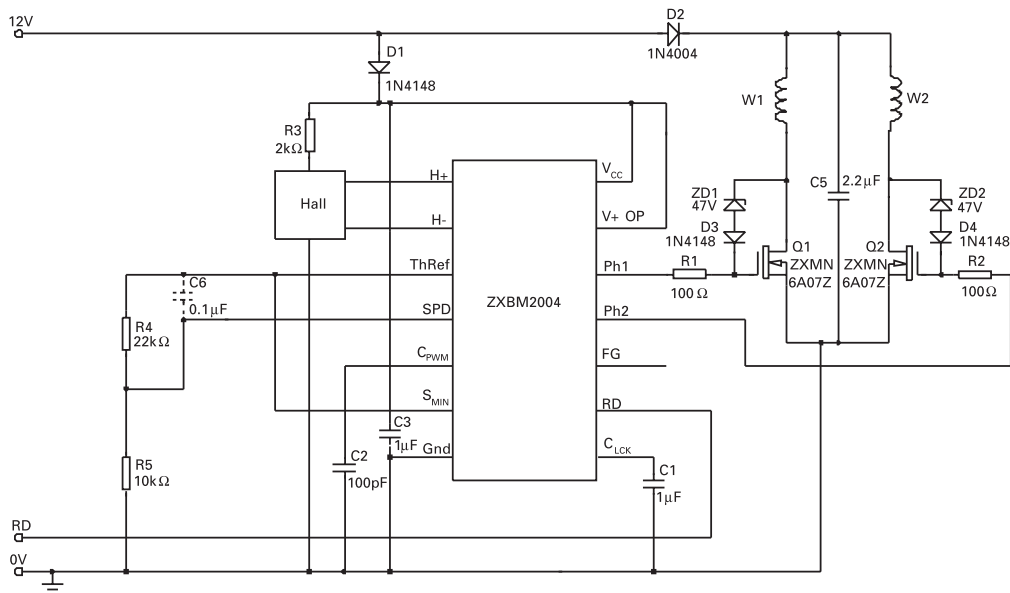

Figure 4: Typical circuit for constant speed operation

ZXBM2004

Drive transistors

Zetex offers a range of devices that are ideally suited to interface between the ZXBM2004 controller and the motor. The following tables show a selection of products. If your needs are not covered by this selection then please refer to the more comprehensive listings that can be found on the Zetex website: www.zetex.com

MOSFETs

Part Number	Polarity	BV_{DSS} V	I_D A	$R_{DS(on)}$ @ $V_{GS} = 10$ Ω	Package
ZXMN10A09K	N	100	7.7	0.085	DDPAK
ZXMN10A11G	N	100	2.4	0.35	SOT223
ZXMN10A08DN8	2 x N	100	2.1	0.25	SO8
ZXMN10A07Z	N	100	1.4	0.7	SOT89
ZXMN6A09K	N	60	11.2	0.045	DDPAK
ZXMN6A25DN8	2 x N	60	4.7	0.055	SO8
ZXMN6A11Z	N	60	3.2	0.14	SOT89
ZXMN6A07Z	N	60	2.2	0.3	SOT89

Bipolar Transistors

Part Number	Polarity	V_{CEO} V	I_C A	$V_{CE(sat)}$ @ I_C/I_B mV @ A/mA	Package
FZT855	NPN	150	4	65 @ 0.5/50	SOT223
FMMT624	NPN	125	1	150 @ 0.5/50	SOT23
ZX5T853G	NPN	100	6	125 @ 2/100	SOT223
FCX493	NPN	100	1	300 @ 0.5/50	SOT89
FCX1053A	NPN	75	3	200 @ 1/10	SOT89
ZX5T851G	NPN	60	6	135 @ 2/50	SOT223
FCX493A	NPN	60	1	500 @ 1/50	SOT89
FCX619	NPN	50	3	260 @ 2/50	SOT89
FMMT619	NPN	50	2	220 @ 2/50	SOT23

ZXBM2004

Notes:

ZXBM2004

PACKAGE OUTLINE QSOP16

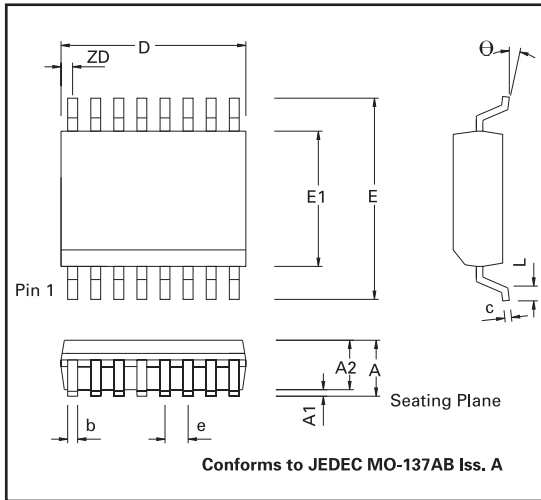

PACKAGE DIMENSIONS

Dim	Inches		Millimeters	
	Min.	Max.	Min.	Max.
A	0.053	0.069	1.35	1.75
A1	0.004	0.010	0.10	0.25
A2	0.049	0.059	1.25	1.50
D	0.189	0.197	4.80	5.00
ZD	0.009 Ref		0.23 BSC	
E	0.228	0.244	5.79	6.20
E1	0.150	0.157	3.81	3.99
L	0.016	0.050	0.41	1.27
e	0.025 BSC		0.64 BSC	
b	0.008	0.012	0.20	0.30
c	0.007	0.010	0.18	0.25
θ	0°	8°	0°	8°
h	0.010	0.020	0.25	0.50

Note: Dimensions in inches are control dimensions, dimensions in millimeters are approximate.

© Zetex Semiconductors plc 2005

Europe	Americas	Asia Pacific	Corporate Headquarters
Zetex GmbH Streitfeldstraße 19 D-81673 München Germany	Zetex Inc 700 Veterans Memorial Hwy Hauppauge, NY 11788 USA	Zetex (Asia) Ltd 3701-04 Metroplaza Tower 1 Hing Fong Road, Kwai Fong Hong Kong	Zetex Semiconductors plc Zetex Technology Park, Chadderton, Oldham, OL9 9LL United Kingdom
Telefon: (49) 89 45 49 49 0 Fax: (49) 89 45 49 49 49 europe.sales@zetex.com	Telephone: (1) 631 360 2222 Fax: (1) 631 360 8222 usa.sales@zetex.com	Telephone: (852) 26100 611 Fax: (852) 24250 494 asia.sales@zetex.com	Telephone (44) 161 622 4444 Fax: (44) 161 622 4446 hq@zetex.com

These offices are supported by agents and distributors in major countries world-wide.

This publication is issued to provide outline information only which (unless agreed by the Company in writing) may not be used, applied or reproduced for any purpose or form part of any order or contract or be regarded as a representation relating to the products or services concerned. The Company reserves the right to alter without notice the specification, design, price or conditions of supply of any product or service.

For the latest product information, log on to www.zetex.com