

ZXCL Series

MICROPOWER SC70-5 & SOT23-5 LOW DROPOUT REGULATORS

ZXCL5213V25, ZXCL5213V26, ZXCL5213V28, ZXCL5213V30, ZXCL5213V33, ZXCL5213V40
ZXCL250, ZXCL260, ZXCL280, ZXCL300, ZXCL330, ZXCL400

DESCRIPTION

The ZXCL series have been designed with space sensitive systems in mind. They are available in the ultra small SC70-5 package, which is half the size of other SOT23 based regulators.

The devices can be used with all types of output capacitors including low ESR ceramics and typical dropout voltage, is only 85mV at 50mA load. Supply current is minimised with a ground pin current of only 50µA at full 150mA load. Logic control allows the devices to be shut down, consuming typically less than 10nA. These features make the device ideal for battery powered applications where power economy is critical.

For applications requiring improved performance over alternative devices, the ZXCL is also offered in the 5 pin SOT23 package with an industry standard pinout.

The devices feature thermal overload and over-current protection and are available with output voltages of 2.5V, 2.6V, 2.8V, 3V, 3.3V and 4V. Other voltage options between 1.5V and 4V can be provided. Contact Zetex for further information.

The ZXCL series are manufactured using CMOS processing, however advanced design techniques mean that output noise is improved even when compared to other bipolar devices.

FEATURES

- 5-pin SC70 package for the ultimate in space saving
- 5-pin SOT23 industry standard pinout
- Can be used with all types of output capacitor
- Low 85mV dropout at 50mA load
- 50µA ground pin current with full 150mA load
- Typically less than 10nA ground pin current on shutdown
- 2.5, 2.6, 2.8, 3, 3.3 and 4 volts output
- Very low noise, without bypass capacitor
- Thermal overload and over-current protection
- -40 to +85°C operating temperature range
- No-load stable

APPLICATIONS

- Cellular and Cordless phones
- Palmtop and laptop computers
- PDA
- Hand held instruments
- Camera, Camcorder, Personal Stereo
- PCMCIA cards
- Portable and Battery-powered equipment

No-Load Stability, the ZXCL device will maintain regulation and is stable with no external load. e.g. CMOS RAM applications.

TYPICAL APPLICATION CIRCUIT

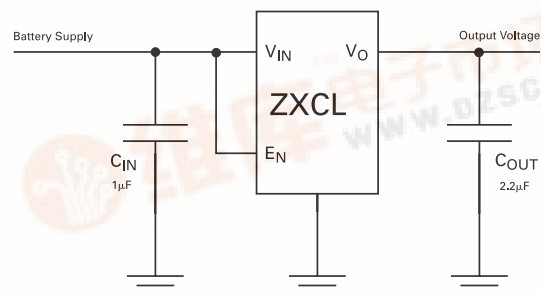

PACKAGE FOOTPRINT

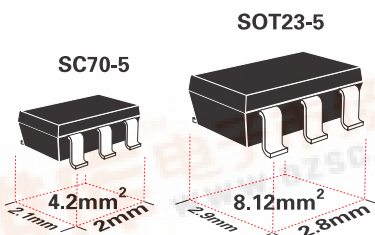

ISSUE 7 - AUGUST 2002

ZETEX

ZXCL Series

ELECTRICAL CHARACTERISTICS

$V_{IN} = V_O + 0.5V$, all values at $T_A = 25^\circ C$ (Unless otherwise stated)

SYMBOL	PARAMETER	CONDITIONS	LIMITS			UNITS
			MIN	TYP	MAX	
V_{DO}	Dropout Voltage Note 3	ZXCL250 / 5213v25 $I_O=10mA$ $I_O=50mA$ $I_O=100mA$		15 85 163	325	mV
		ZXCL260 / 5213v26 $I_O=10mA$ $I_O=50mA$ $I_O=100mA$		15 85 155	310	mV
		ZXCL280 / 5213v28 $I_O=10mA$ $I_O=50mA$ $I_O=100mA$		15 85 140	280	mV
		ZXCL300 / 5213v30 $I_O=10mA$ $I_O=50mA$ $I_O=100mA$		15 85 140	280	mV
		ZXCL330 / 5213v33 $I_O=10mA$ $I_O=50mA$ $I_O=100mA$		15 85 140	280	mV
		ZXCL400 / 5213v40 $I_O=10mA$ $I_O=50mA$ $I_O=100mA$		15 85 140	280	mV
ΔV_{LNR}	Line Regulation	$V_{IN}=(V_O+0.5V)$ to 5.5V, $I_O=1mA$		0.02	0.1	%/V
ΔV_{LDR}	Load Regulation	$I_O=1mA$ to 100mA		0.01	0.04	%/mA
E_N	Output Noise Voltage	$f=10Hz$ to 100kHz, $C_O=10\mu F$,		50		μV rms
V_{ENH}	Enable pin voltage for normal operation	$T_A = -40^\circ C$	2 2.2		10	V
V_{ENL}	Enable pin voltage for output shutdown		0		0.8	V
V_{ENHS}	Enable pin hysteresis			150		mV
I_{EN}	Enable Pin input current	$V_{EN}=5.5V$			100	nA
I_{QSD}	Shutdown supply current	$V_{EN}=0V$			1	μA
T_{SD}	Thermal Shutdown Temperature		125		165	$^\circ C$

Device testing is performed at $T_A=25^\circ C$. Device thermal performance is guaranteed by design.

Note1: Maximum power dissipation is calculated assuming the device is mounted on a PCB measuring 2 inches square

Note 2: Output Voltage will start to rise when V_{IN} exceeds a value of approximately 1.3V. For normal operation, $V_{IN} (min) > V_{OUT} (nom) + 0.5V$.

Note 3: Dropout voltage is defined as the difference between V_{IN} and V_O , when V_O has dropped 100mV below its nominal value. Nominal value of V_O is defined at $V_{IN}=V_O+0.5V$.

ZXCL Series

TYPICAL CHARACTERISTICS (ZXCL280 / 5213 shown)

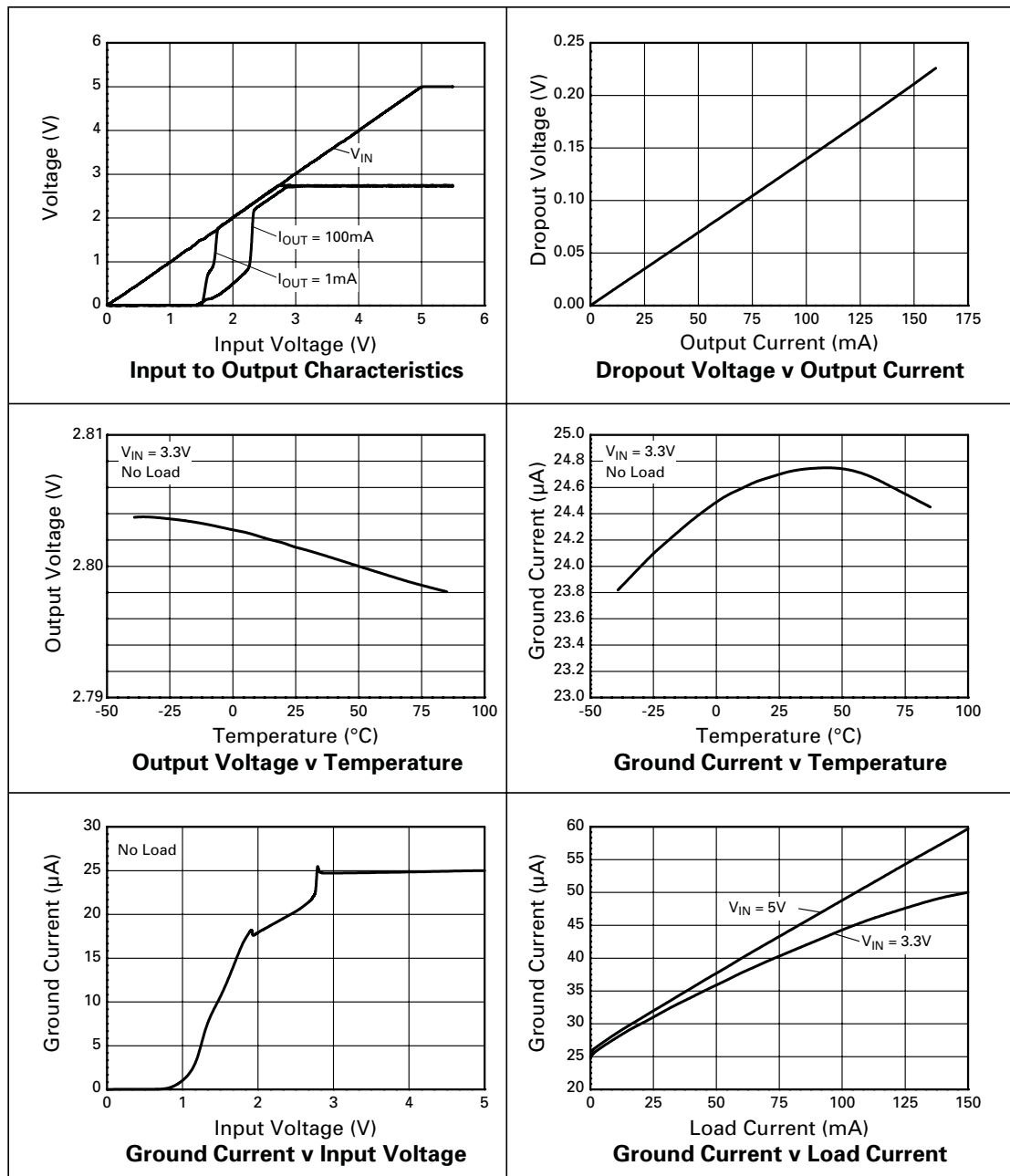

ZXCL Series

TYPICAL CHARACTERISTICS

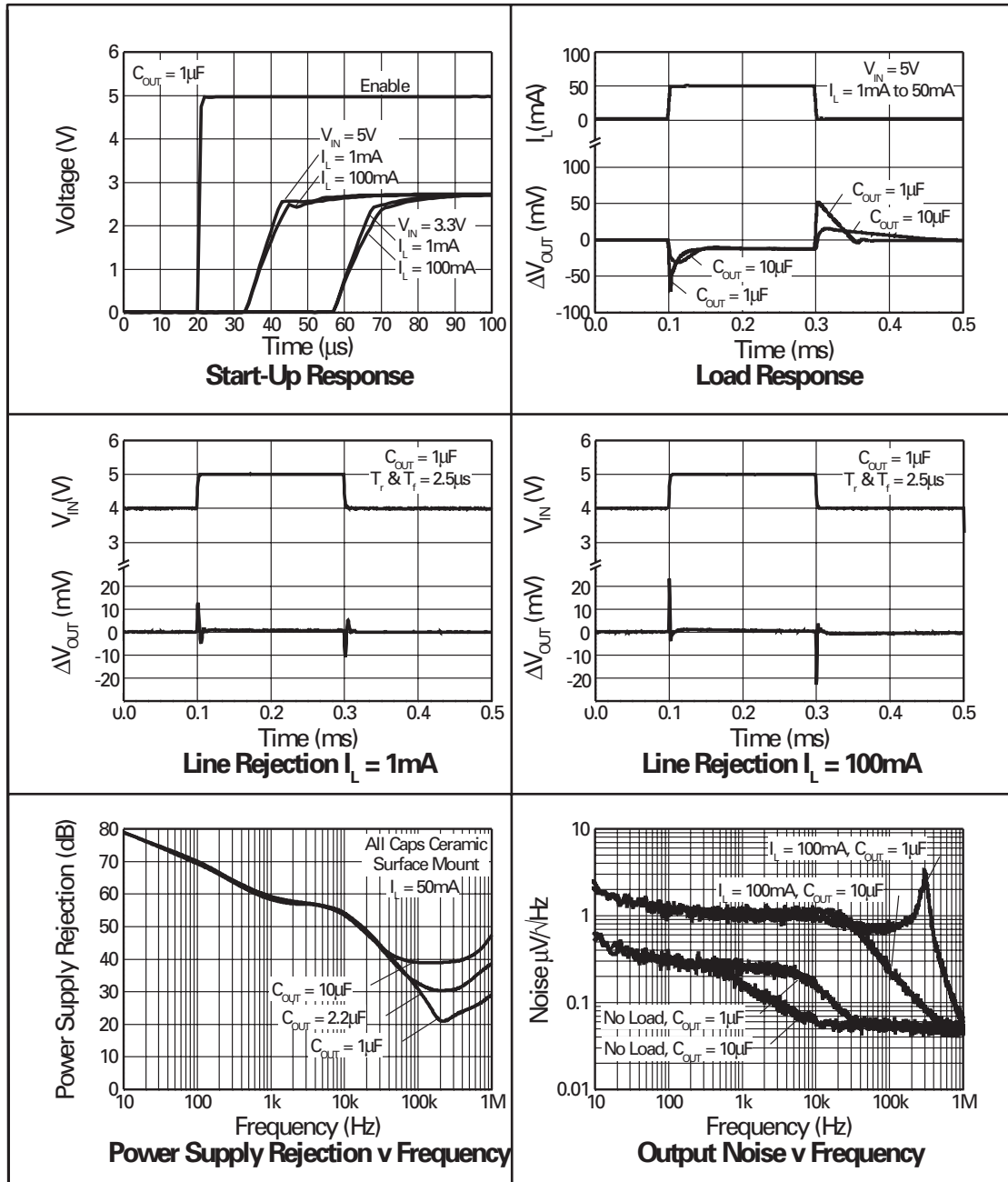

ZXCL Series

PIN DESCRIPTION

Pin Name	Pin Function
V _{IN}	Supply Voltage
G _{ND}	Ground
E _N	Active HIGH Enable input. TTL/CMOS logic compatible. Connect to V _{IN} or logic high for normal operation
N/C	No Connection
V _O	Regulator Output

CONNECTION DIAGRAMS

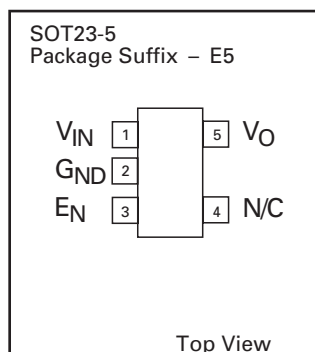

ZXCLxxx

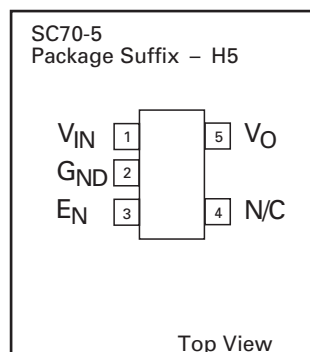

ZXCLxxx

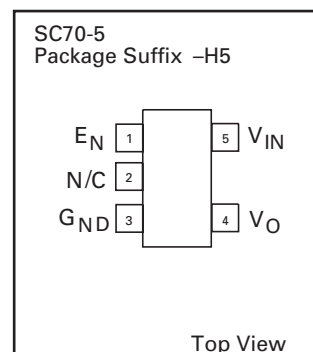

ZXCL5213Vxx

SCHEMATIC DIAGRAM

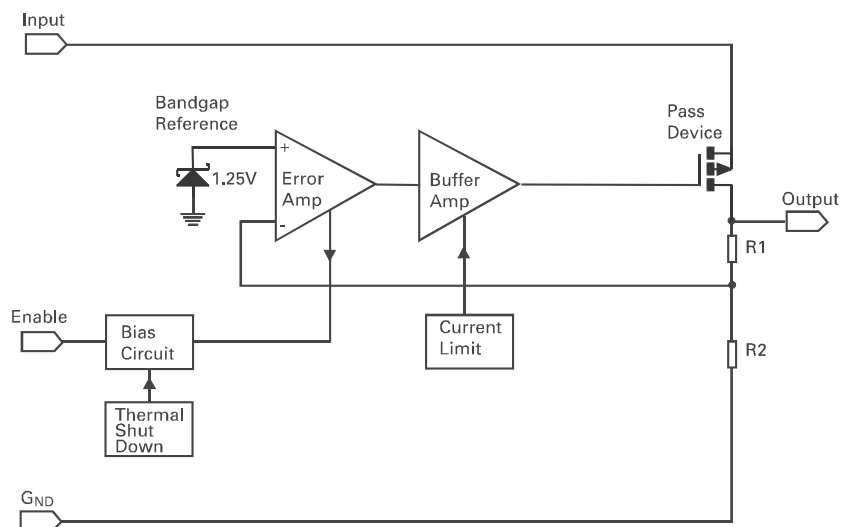

ZXCL Series

Input to Output Diode

In common with many other LDO regulators, the ZXCL device has an inherent diode associated with the output series pass transistor. This diode has its anode connected to the output and its cathode to the input. The internal diode is normally reverse biased, but will conduct if the output is forced above the input by more than a V_{BE} (approximately 0.6V). Current will then flow from V_{out} to V_{in} . For safe operation, the maximum current in this diode should be limited to 5mA continuous and 30mA peak. An external schottky diode may be used to provide protection when this condition cannot be satisfied.

Increased Output current

Any ZXCL series device may be used in conjunction with an external PNP transistor to boost the output current capability. In the application circuit shown below, a FM717 device is employed as the external pass element. This SOT23 device can supply up to 2.5A maximum current subject to the thermal dissipation limits of the package (625mW). Alternative devices may be used to supply higher levels of current. Note that with this arrangement, the dropout voltage will be increased by the V_{BE} drop of the external device. Also, care should be taken to protect the pass transistor in the event of excessive output current.

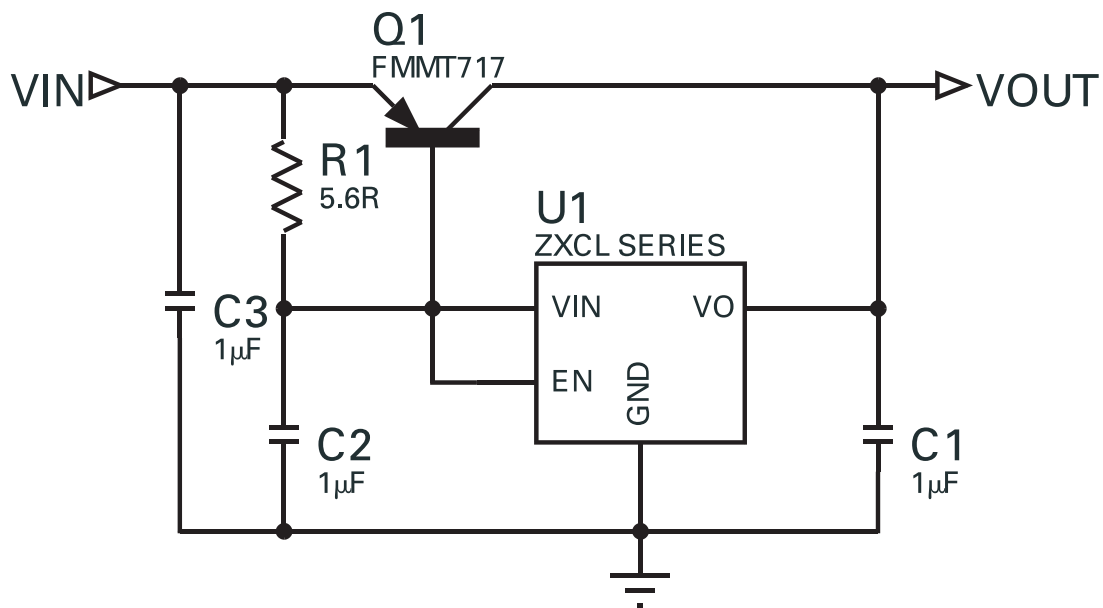

Scheme to boost output current to 2A

ZXCL Series

APPLICATIONS INFORMATION

Enable Control

A TTL compatible input is provided to allow the regulator to be shut down. A low voltage on the Enable pin puts the device into shutdown mode. In this mode the regulator circuit is switched off and the quiescent current reduces to virtually zero (typically less than 10nA) for input voltages above the minimum operating threshold of the device. A high voltage on the Enable pin ensures normal operation.

The Enable pin can be connected to V_{IN} or driven from an independent source of up to 10V maximum. (e.g. CMOS logic) for normal operation. There is no clamp diode from the Enable pin to V_{IN} , so the V_{IN} pin may be at any voltage within its operating range irrespective of the voltage on the Enable pin. However input voltage rise time should be kept below 5ms to ensure consistent start-up response.

Current Limit

The ZXCL devices include a current limit circuit which restricts the maximum output current flow to typically 230mA. Practically the range of over-current should be considered as minimum 160mA to maximum 800mA. The device's robust design means that an output short circuit to any voltage between ground and V_{OUT} can be tolerated for an indefinite period.

Thermal Overload

Thermal overload protection is included on chip. When the device junction temperature exceeds a minimum 125°C the device will shut down. The sense circuit will re-activate the output as the device cools. It will then cycle until the overload is removed. The thermal overload protection will be activated when high load currents or high input to output voltage differentials cause excess dissipation in the device.

Start up delay

A small amount of hysteresis is provided on the Enable pin to ensure clean switching. This feature can be used to introduce a start up delay if required. Addition of a simple RC network on the Enable pin provides this function. The following diagram illustrates this circuit connection. The equation provided enables calculation of the delay period.

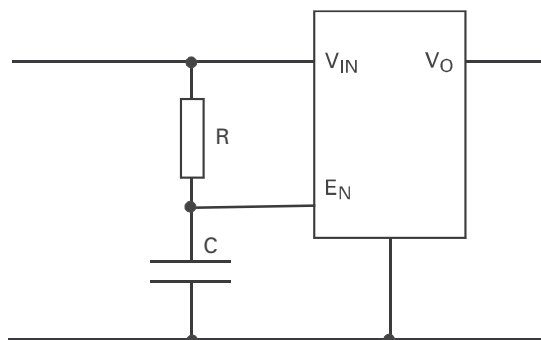

Figure 1 Circuit Connection

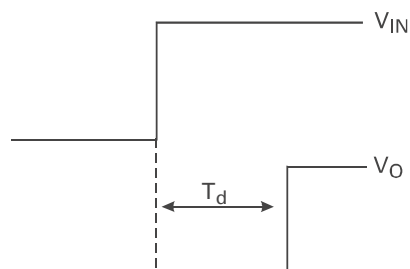

Figure 2 Start up delay (T_d)

$$T_{d(NOM)} = RC \ln \left(\frac{V_{IN}}{V_{IN} - 1.5} \right)$$

Calculation of start up delay as above

ZXCL Series

APPLICATIONS INFORMATION (Cont)

Power Dissipation

The maximum allowable power dissipation of the device for normal operation (P_{max}), is a function of the package junction to ambient thermal resistance (θ_{ja}), maximum junction temperature (T_{jmax}), and ambient temperature (T_{amb}), according to the expression:

$$P_{max} = (T_{jmax} - T_{amb}) / \theta_{ja}$$

The maximum output current (I_{max}) at a given value of input voltage (V_{IN}) and output voltage (V_{OUT}) is then given by

$$I_{max} = P_{max} / (V_{IN} - V_{OUT})$$

The value of θ_{ja} is strongly dependent upon the type of PC board used. Using the SC70 package it will range from approximately 280°C/W for a multi-layer board to around 450°C/W for a single sided board. It will range from 180°C/W to 300°C/W for the SOT23-5 package. To avoid entering the thermal shutdown state, T_{jmax} should be assumed to be 125°C and I_{max} less than the over-current limit, (I_{OLIM}). Power derating for the SC70 and SOT23-5 packages is shown in the following graph.

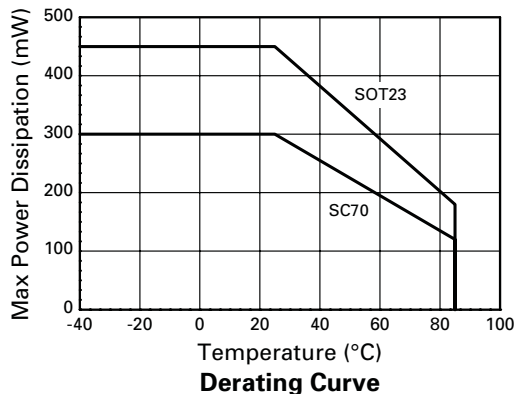

Capacitor Selection and Regulator Stability

The device is designed to operate with all types of output capacitor, including tantalum and low ESR ceramic. For stability over the full operating range from no load to maximum load, an output capacitor with a minimum value of 1µF is recommended, although this can be increased without limit to improve load transient performance. Higher values of output capacitor will also reduce output noise. Capacitors with ESR less than 0.5Ω are recommended for best results.

The dielectric of the ceramic capacitance is an important consideration for the ZXCL Series operation over temperature. Zetex recommends minimum dielectric specification of X7R for the input and output capacitors. For example a ceramic capacitor with X7R dielectric will lose 20% of its capacitance over a -40°C to 85°C temperature range, whereas a capacitor with a Y5V dielectric loses 80% of its capacitance at -40°C and 75% at 85°C.

An input capacitor of 1µF (ceramic or tantalum) is recommended to filter supply noise at the device input and will improve ripple rejection.

The input and output capacitors should be positioned close to the device, and a ground plane board layout should be used to minimise the effects of parasitic track resistance.

Dropout Voltage

The output pass transistor is a large PMOS device, which acts like a resistor when the regulator enters the dropout region. The dropout voltage is therefore proportional to output current as shown in the typical characteristics.

Ground Current

The use of a PMOS device ensures a low value of ground current under all conditions including dropout, start-up and maximum load.

Power Supply Rejection and Load Transient Response

Line and Load transient response graphs are shown in the typical characteristics.

These show both the DC and dynamic shift in the output voltage with step changes of input voltage and load current, and how this is affected by the output capacitor.

If improved transient response is required, then an output capacitor with lower ESR value should be used. Larger capacitors will reduce over/undershoot, but will increase the settling time. Best results are obtained using a ground plane layout to minimise board parasitics.

ZXCL Series

S70-5 PACKAGE OUTLINE

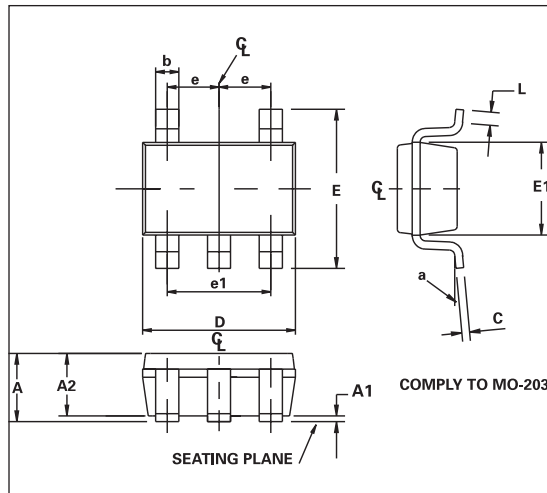

CONTROLLING DIMENSIONS IN MILLIMETRES
APPROX CONVERTED DIMENSIONS IN INCHES

SC70-5 PACKAGE DIMENSIONS

DIM	MILLIMETRES		INCHES	
	MIN	MAX	MIN	MAX
A	—	1.00	—	0.0393
A1	—	0.10	—	0.0039
A2	0.70	0.90	0.0275	0.0354
b	0.15	0.30	0.006	0.0118
C	0.08	0.25	0.0031	0.0098
D	2.0 BSC		0.0787 BSC	
E	2.10 BSC		0.0826 BSC	
E1	1.25 BSC		0.0492 BSC	
e	0.65 BSC		0.0255 BSC	
e1	1.30 BSC		0.0511 BSC	
L	0.26	0.46	0.0102	0.0181
a	0°	8°	0°	8°

SOT23-5 PACKAGE DIMENSIONS

DIM	MILLIMETRES		INCHES	
	MIN	MAX	MIN	MAX
A	0.90	1.45	0.0354	0.0570
A1	0.00	0.15	0.00	0.0059
A2	0.90	1.3	0.0354	0.0511
b	0.20	0.50	0.0078	0.0196
C	0.09	0.26	0.0035	0.0102
D	2.70	3.10	0.1062	0.1220
E	2.20	3.20	0.0866	0.1181
E1	1.30	1.80	0.0511	0.0708
e	0.95 REF		0.0374 REF	
e1	1.90 REF		0.0748 REF	
L	0.10	0.60	0.0039	0.0236
a°	0	30	0	30

SOT23-5 PACKAGE INFORMATION

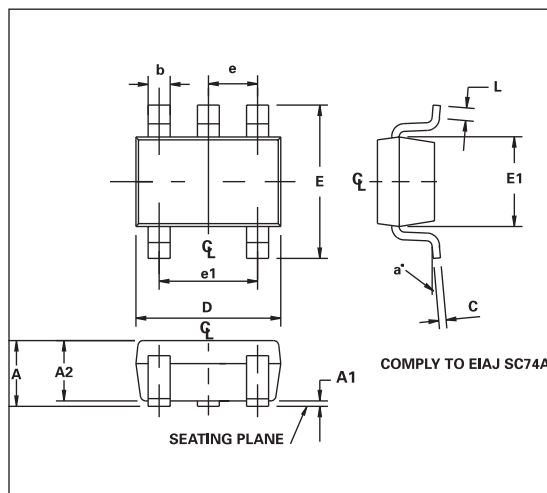

CONTROLLING DIMENSIONS IN MILLIMETRES
APPROX CONVERTED DIMENSIONS IN INCHES

ZXCL Series

ORDERING INFORMATION

Device	Output Voltage V	Package	Partmarking
ZXCL250H5	2.5	SC70	L25A
ZXCL260H5	2.6	SC70	L26A
ZXCL280H5	2.8	SC70	L28A
ZXCL300H5	3.0	SC70	L30A
ZXCL330H5	3.3	SC70	L33A
ZXCL400H5	4.0	SC70	L40A
ZXCL5213V25H5	2.5	SC70	L25C
ZXCL5213V26H5	2.6	SC70	L26C
ZXCL5213V28H5	2.8	SC70	L28C
ZXCL5213V30H5	3.0	SC70	L30C
ZXCL5213V33H5	3.3	SC70	L33C
ZXCL5213V40H5	4.0	SC70	L40C
ZXCL250E5	2.5	SOT23-5	L25B
ZXCL260E5	2.6	SOT23-5	L26B
ZXCL280E5	2.8	SOT23-5	L28B
ZXCL300E5	3.0	SOT23-5	L30B
ZXCL330E5	3.3	SOT23-5	L33B
ZXCL400E5	4.0	SOT23-5	L40B

© Zetex plc 2002

Europe		Americas	Asia Pacific
Zetex plc Fields New Road Chadderton Oldham, OL9 8NP United Kingdom Telephone (44) 161 622 4422 Fax: (44) 161 622 4420 uk.sales@zetex.com	Zetex GmbH Streitfeldstraße 19 D-81673 München Germany Telefon: (49) 89 45 49 49 0 Fax: (49) 89 45 49 49 49 europe.sales@zetex.com	Zetex Inc 700 Veterans Memorial Hwy Hauppauge, NY11788 USA Telephone: (631) 360 2222 Fax: (631) 360 8222 usa.sales@zetex.com	Zetex (Asia) Ltd 3701-04 Metroplaza, Tower 1 Hing Fong Road Kwai Fong Hong Kong Telephone: (852) 26100 611 Fax: (852) 24250 494 asia.sales@zetex.com

These offices are supported by agents and distributors in major countries world-wide.

This publication is issued to provide outline information only which (unless agreed by the Company in writing) may not be used, applied or reproduced for any purpose or form part of any order or contract or be regarded as a representation relating to the products or services concerned. The Company reserves the right to alter without notice the specification, design, price or conditions of supply of any product or service.

For the latest product information, log on to www.zetex.com

ISSUE 7 - AUGUST 2002

