

## HIGH-SIDE CURRENT MONITOR

### DESCRIPTION

The ZXCT1009 is a high side current sense monitor. Using this device eliminates the need to disrupt the ground plane when sensing a load current.

It takes a high side voltage developed across a current shunt resistor and translates it into a proportional output current.

A user defined output resistor scales the output current into a ground-referenced voltage.

The wide input voltage range of 20V down to as low as 2.5V make it suitable for a range of applications. A minimum operating current of just 4 $\mu$ A, combined with its SOT23 package make it a unique solution, suitable for portable battery equipment.

### FEATURES

- Low cost, accurate high-side current sensing.
- Output voltage scaling.
- Up to 2.5V sense voltage.
- 2.5V – 20V supply range.
- 4 $\mu$ A quiescent current.
- 1% typical accuracy.
- SOT23 & SM8<sup>T</sup> packages.

### APPLICATIONS

- Battery Chargers
- Smart Battery Packs
- DC Motor control
- Over current monitor
- Power Management
- Level translating
- Programmable current source

### APPLICATION CIRCUIT

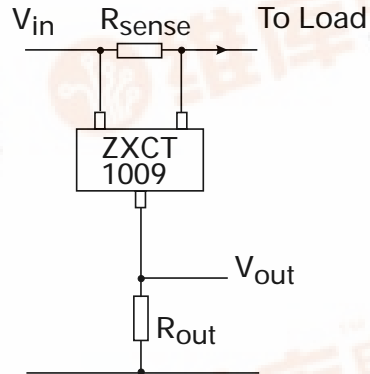

### ORDERING INFORMATION

PART NUMBER	PACKAGE	PARTMARKING
ZXCT1009F	SOT23	109
ZXCT1009T8	SM8	ZXCT1009

SM8 due for release May 2001

Sampling April 2001

# ZXCT1009

## ABSOLUTE MAXIMUM RATINGS

Voltage on any pin	-0.6V to 20V (relative to $I_{out}$ )
Continuous output current	25mA
Continuous sense voltage	$V_{in} + 0.5V > V_{sense}^{\dagger} > V_{in} - 5V$
Operating Temperature	-40 to 85° C
Storage Temperature	-55 to 125° C
Package Power Dissipation	( $T_A = 25^{\circ}C$ )
SOT23	450mW
SM8	2W

## ELECTRICAL CHARACTERISTICS

Test Conditions  $T_A = 25^{\circ}C$ ,  $V_{in} = 5V$ ,  $R_{out} = 100\Omega$

SYMBOL	PARAMETER	CONDITIONS	LIMITS			UNIT
			Min	Typ	Max	
$V_{in}$	$V_{CC}$ Range		2.5		20	V
$I_{out}^1$	Output current	$V_{sense}=0V$	1	4	15	$\mu A$
		$V_{sense}=10mV$	90	104	120	$\mu A$
		$V_{sense}=100mV$	0.975	1.002	1.025	mA
		$V_{sense}=200mV$	1.95	2.0	2.05	mA
		$V_{sense}=1V$	9.6	9.98	10.2	mA
$V_{sense}^{\dagger}$	Sense Voltage		0		2500	mV
$I_{sense}$	Load pin input current				100	nA
Acc	Accuracy	$R_{sense} = 0.1\Omega$ $V_{sense}=200mV$	-2.5		2.5	%
Gm	Transconductance, $I_{out} / V_{sense}$			10000		$\mu A/V$
BW	Bandwidth	RF $P_{in} = -20dBm^{\ddagger}$				
		$V_{sense} = 10mV$ dc		300		kHz
		$V_{sense} = 100mV$ dc		2		MHz

<sup>1</sup> Includes input offset voltage contribution

<sup>†</sup> $V_{sense}=V_{in}-V_{load}$

<sup>‡</sup> -20dBm=63mVp-p into 50 $\Omega$

## TYPICAL CHARACTERISTICS

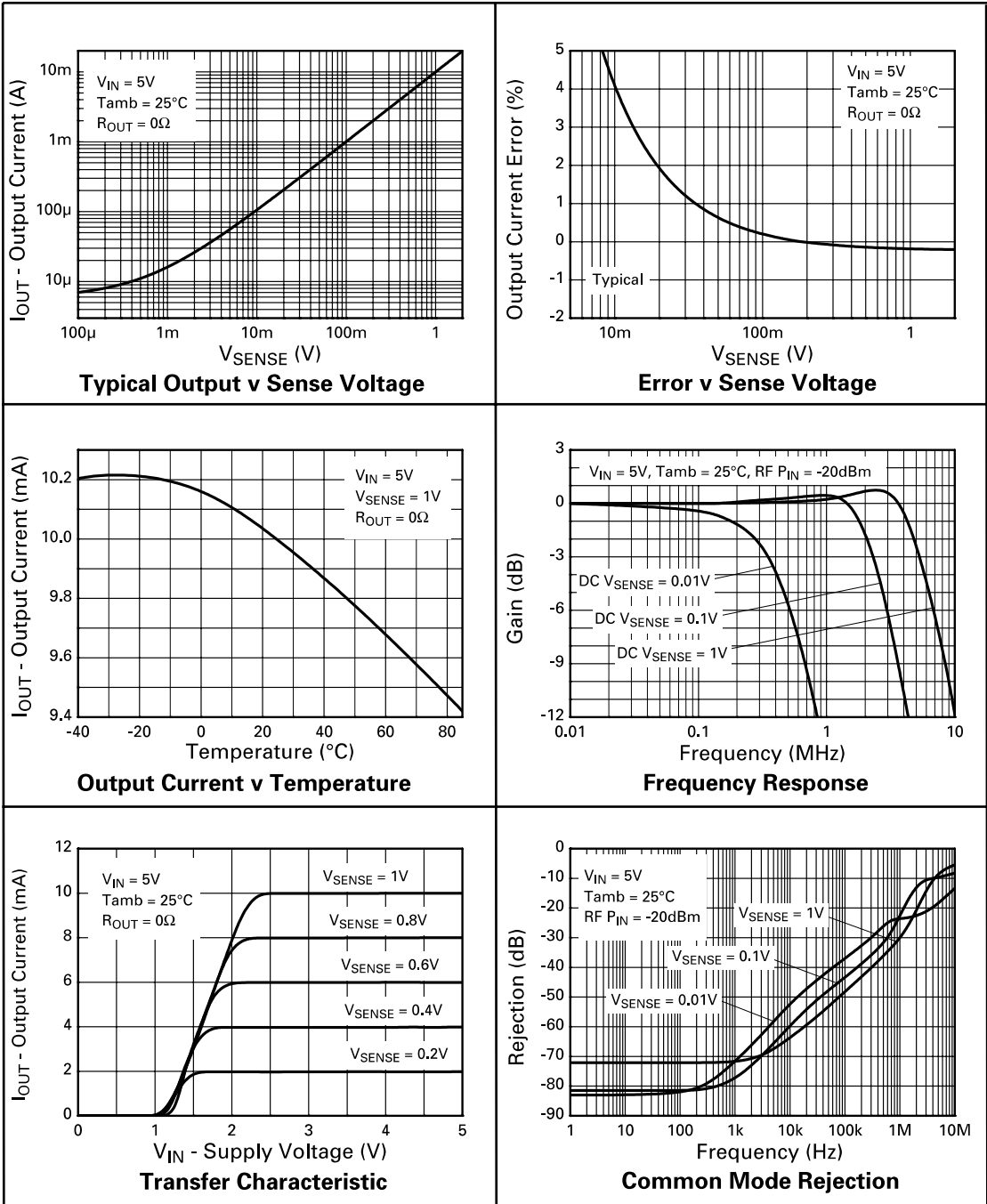

# ZXCT1009

## PIN DESCRIPTION

Pin Name	Pin Function
$V_{in}$	Supply Voltage
Load	Connection to load/battery
$I_{out}$	Output current, proportional to $V_{in} - V_{Load}$

## CONNECTION DIAGRAMS

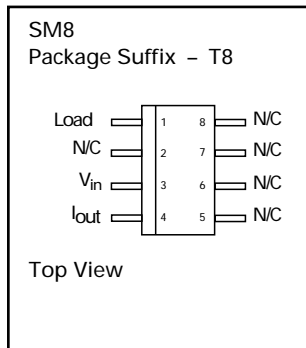
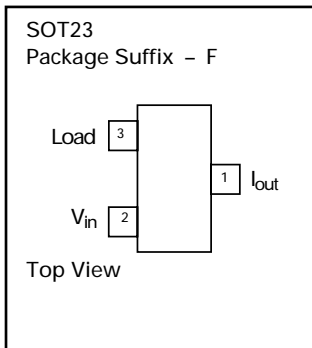

## SCHEMATIC DIAGRAM

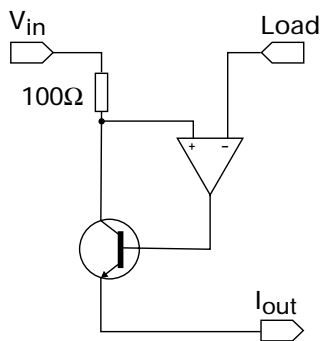

# ZXCT1009

## POWER DISSIPATION

The maximum allowable power dissipation of the device for normal operation ( $P_{max}$ ), is a function of the package junction to ambient thermal resistance ( $\theta_{ja}$ ), maximum junction temperature ( $T_{jmax}$ ), and ambient temperature ( $T_{amb}$ ), according to the expression:

$$P_{max} = (T_{jmax} - T_{amb}) / \theta_{ja}$$

The device power dissipation,  $P_D$  is given by the expression:

$$P_D = I_{out} \cdot (V_{in} - V_{out}) \text{ Watts}$$

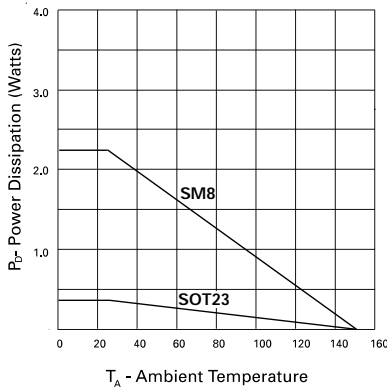

## APPLICATIONS INFORMATION

The following lines describe how to scale a load current to an output voltage.

$$V_{sense} = V_{in} - V_{load}$$

$$V_{out} = 0.01 \times V_{sense} \times R_{out}^1$$

E.g.

A 1A current is to be represented by a 100mV output voltage:

1) Choose the value of  $R_{sense}$  to give  $50mV > V_{sense} > 500mV$  at full load.

For example  $V_{sense} = 100mV$  at 1.0A.  $R_{sense} = 0.1/1.0 \Rightarrow 0.1$  ohms.

2) Choose  $R_{out}$  to give  $V_{out} = 100mV$ , when  $V_{sense} = 100mV$ .

Rearranging <sup>1</sup> for  $R_{out}$  gives:

$$R_{out} = V_{out} / (V_{sense} \times 0.01)$$

$$R_{out} = 0.1 / (0.1 \times 0.01) = 100 \Omega$$

## TYPICAL CIRCUIT APPLICATION

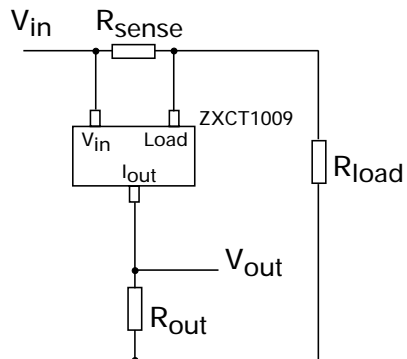

Where  $R_{load}$  represents any load including DC motors, a charging battery or further circuitry that requires monitoring,  $R_{sense}$  can be selected on specific requirements of accuracy, size and power rating.

# ZXCT1009

## APPLICATIONS INFORMATION (Continued)

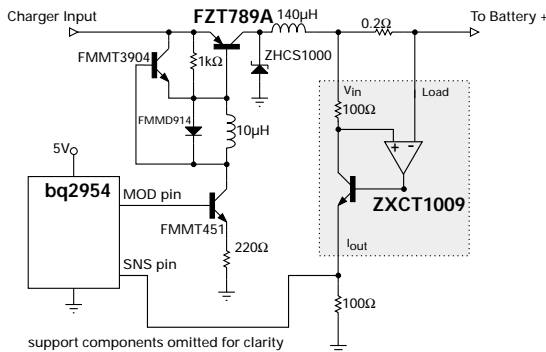

### Li-Ion Charger Circuit

The above figure shows the ZXCT1009 supporting the Benchmarq bq2954 Charge Management IC. Most of the support components for the bq2954 are omitted for clarity. This design also uses the Zetex FZT789A high current Super-β PNP as the switching transistor in the DC-DC step down converter and the FMMDT451 as the drive NPN for the FZT789A. The circuit can be configured to charge up to four Li-Ion cells at a charge current of 1.25A. Charge can be terminated on maximum voltage, selectable minimum current, or maximum time out. Switching frequency of the PWM loop is approximately 120kHz.

The ZXCT1009 is intended as a direct functional replacement for the ZDS1009, which is featured in a complete design from Unitrode/Texas Instruments on the Li-Ion charger circuit shown above. Reference: DVS2954S1H Li-Ion Charger Development System.

### Transient Protection

An additional resistor, R<sub>lim</sub> can be added in series with R<sub>out</sub> (figure 1.0), to limit the current from I<sub>out</sub>. Any circuit connected to V<sub>out</sub> will be protected from input voltage transients. This can be of particular use in automotive applications where load dump and other common transients need to be considered.

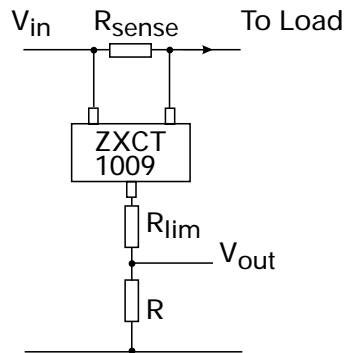

**Figure 1.0**  
ZXCT1009 with additional current limiting Resistor R<sub>lim</sub>.

Assuming the worst case condition of V<sub>out</sub> = 0V; providing a low impedance to a transient, the minimum value of R<sub>lim</sub> is given by:-

$$R_{lim}(\min) = \frac{V_{pk} - V_{max}}{I_{pk}}$$

V<sub>pk</sub> = Peak transient voltage to be withstood

V<sub>max</sub> = Maximum working Voltage = 20V

I<sub>pk</sub> = Peak output current = 40mA

The maximum value of R<sub>lim</sub> is set by V<sub>in</sub>(min), V<sub>out</sub>(max) and the dropout voltage (see transfer characteristic on page 3) of the ZXCT1009 :-

$$R_{lim}(\max) = \frac{R_{out}[V_{in}(\min) - (V_{dp} + V_{out}(\max))]}{V_{out}(\max)}$$

V<sub>in</sub>(min) = Minimum Supply Operating Voltage

V<sub>dp</sub> = Dropout Voltage

V<sub>out</sub> (max) = Maximum Operating Output Voltage

# ZXCT1009

## APPLICATIONS INFORMATION (Continued)

### PCB trace shunt resistor for low cost solution.

The figure below shows output characteristics of the device when using a PCB resistive trace for a low cost solution in replacement for a conventional shunt resistor. The graph shows the linear rise in voltage across the resistor due to the PTC of the material and demonstrates how this rise in resistance value over temperature compensates for the NTC of the device.

The figure opposite shows a PCB layout suggestion. The resistor section is 25mm x 0.25mm giving approximately 150mΩ using 1oz copper. The data for the normalised graph was obtained using a 1A load current and a 100Ω output resistor. An electronic version of the PCB layout is available at [www.zetex.com/isense](http://www.zetex.com/isense)

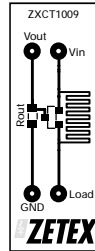

Actual Size

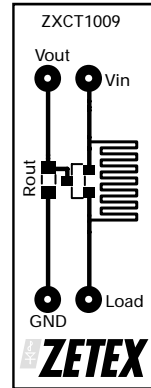

Layout shows area of shunt resistor compared to SOT23 package. Not actual size

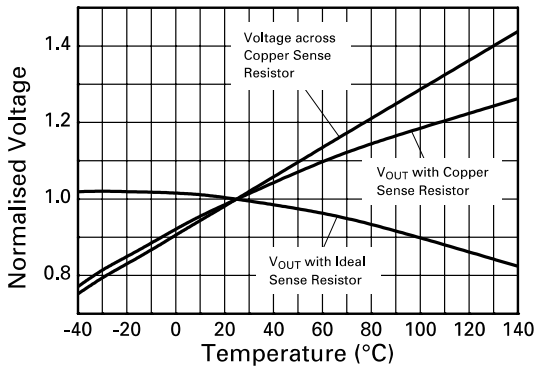

Effect of Sense Resistor Material on Temperature Performance

# ZXCT1009

## PACKAGE DIMENSIONS SOT23

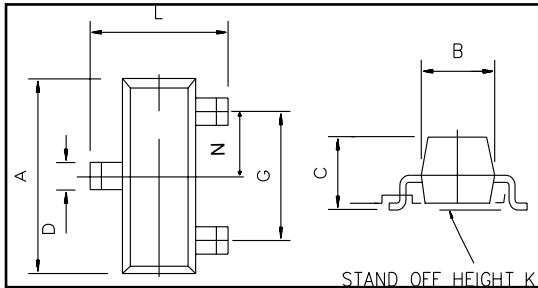

DIM	Millimetres		Inches	
	Min	Max	Min	Max
A	2.67	3.05	0.105	0.120
B	1.20	1.40	0.047	0.055
C	-	1.10	-	0.043
D	0.37	0.53	0.0145	0.021
F	0.085	0.15	0.0033	0.0059
G	NOM 1.9		NOM 0.075	
K	0.01	0.10	0.0004	0.004
L	2.10	2.50	0.0825	0.0985
N	NOM 0.95		NOM 0.037	

## PACKAGE DIMENSIONS SM8

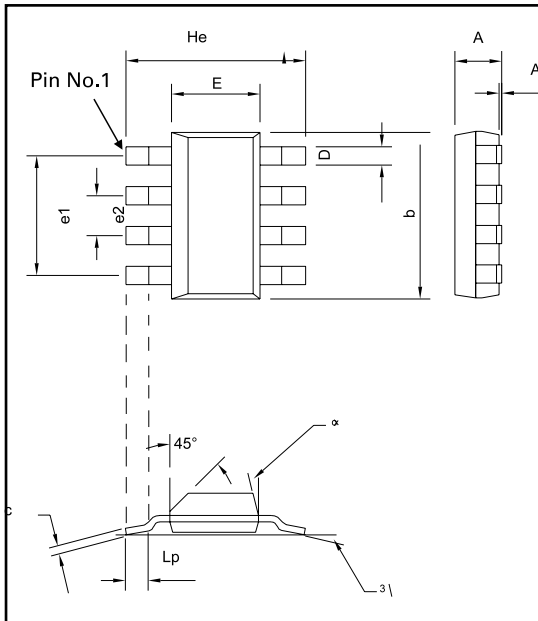

DIM	Millimetres			Inches		
	Min	Typ	Max	Min	Typ	Max
A	-	-	1.7	-	-	0.067
A1	0.02	-	0.1	0.0008	-	0.004
b	-	0.7	-	-	0.028	-
c	0.24	-	0.32	0.009	-	0.013
D	6.3	-	6.7	0.248	-	0.264
E	3.3	-	3.7	0.130	-	0.145
e1	-	4.59	-	-	0.180	-
e2	-	1.53	-	-	0.060	-
He	6.7	-	7.3	0.264	-	0.287
Lp	0.9	-	-	0.035	-	-
alpha	-	-	15°	-	-	15°



**ZETEX**

Zetex plc.  
Fields New Road, Chadderton, Oldham, OL9-8NP, United Kingdom.  
Telephone: (44)161 622 4422 (Sales), (44)161 622 4444 (General Enquiries)  
Fax: (44)161 622 4420

Zetex GmbH  
Streitfeldstraße 19  
D-81673 München  
Germany  
Telefon: (49) 89 45 49 49 0  
Fax: (49) 89 45 49 49 49

Zetex Inc.  
47 Mall Drive, Unit 4  
Commack NY 11725  
USA  
Telephone: (631) 543-7100  
Fax: (631) 864-7630

Zetex (Asia) Ltd.  
3701-04 Metroplaza, Tower 1  
Hing Fong Road,  
Kwai Fong, Hong Kong  
Telephone: (852) 26100 611  
Fax: (852) 24250 494

These are supported by  
agents and distributors in  
major countries world-wide  
© Zetex plc 2000

Internet: <http://www.zetex.com>

This publication is issued to provide outline information only which (unless agreed by the Company in writing) may not be used, applied or reproduced for any purpose or form part of any order or contract or be regarded as a representation relating to the products or services concerned. The Company reserves the right to alter without notice the specification, design, price or conditions of supply of any product or service.