

ZXCT1030

HIGH-SIDE CURRENT MONITOR WITH COMPARATOR

DESCRIPTION

The ZXCT1030 is a high side current sense monitor containing an internal reference and comparator with a non-latching output. Using this device eliminates the need to disrupt the ground plane when sensing a load current.

The wide input voltage range of 20V down to as low as 2.2V make it suitable for a range of applications. Dynamics and supply current are optimised for the processing of fast pulses, associated with switch mode applications.

APPLICATIONS

- Battery chargers
- Electronic fuse
- DC motor control
- Over current monitor
- Power management
- Inrush current limiting

FEATURES

- Low cost, accurate high-side current sensing.
- Output voltage scaling.
- Up to 18V output.
- 2.2V – 20V supply range.
- 270 μ A quiescent current.
- 1.5% typical accuracy.
- MSOP8 Package.
- Voltage reference on chip
- Comparator on chip

FUNCTIONAL BLOCK DIAGRAM

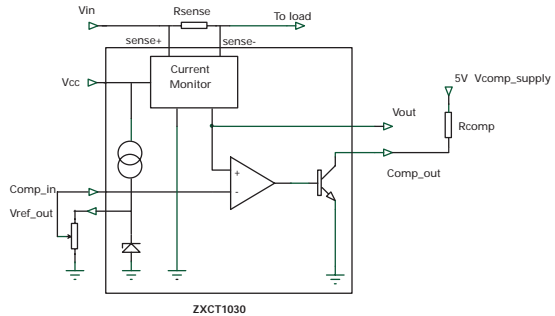

ORDERING INFORMATION

Device	Reel size	Tape width	Quantity per reel
ZXCT1030X8TA	7"	12mm	500 units
ZXCT1030X8TC	13"	12mm	2500 units

DEVICE MARKING

- ZXCT
1030

ZXCT1030

Absolute Maximum Ratings

Voltage on any pin	-0.6V and $V_{CC} + 0.6V$
Operating Temperature	-40 to 85°C
Storage Temperature	-55 to 125°C
Package Power Dissipation	($T_A = 25^\circ C$)
MSOP8	500mW

ELECTRICAL CHARACTERISTICS Test Conditions $T_A = 25^\circ C$, $V_{in} = V_{CC} = 15V$

SYMBOL	PARAMETER	CONDITIONS	LIMITS			UNIT
			Min	Typ	Max	
V_{CC}	V_{CC} Range		2.2		20	V
V_{sense+}	Sense+ range		2.2		V_{CC}	
V_{out}	Output Voltage	$V_{sense} = 0V$ $V_{sense} = 10mV$ $V_{sense} = 30mV$ $V_{sense} = 50mV$ $V_{sense} = 100mV$ $V_{sense} = 500mV$	0 88 284 480 970 4500	2 100 300 500 1000 5000	10 112 316 520 1030 5500	mV mV mV mV mV mV
R_{out}	Output resistance	$V_{sense-} = 15V$, $V_{out} = 1V$	1.2	1.5	1.8	K Ω
V_{out} TC	V_{out} temperature coefficient			30		ppm/ $^\circ C$
I_{CC}	Supply current	$V_{sense-} = 15V$	170	270	350	μA
I_{sense+}	Sense+ input current		25	48	90	μA
I_{sense-}	Sense- input current	$V_{sense-} = 14.9V$	25	70	220	nA
V_{sense}^2	Sense Voltage		0		500	mV
V_{cm}^3	Common Mode Range	$V_{CC} = 15V$ $V_{comp_supply} = 5V$ $V_{comp_in} = V_{ref}$ $V_{sense} = 10mV$	2.8			V
Acc	Accuracy	$V_{sense} = 100mV$	-3		3	%
Gain	V_{out} / V_{sense}	$V_{sense} = 100mV$	9.7	10.0	10.3	
BW	Bandwidth	$V_{sense} = 10mV_{p-p}$ $V_{sense} = 100mV_{p-p}$		3 6		MHz MHz

² $V_{sense} = (V_{sense+}) - (V_{sense-})$

³ Level of V_{in} where comparator output defaults to 'off'.

ZXCT1030

Absolute Maximum Ratings

Voltage on any pin	-0.6V and $V_{CC} + 0.6 V$
Operating Temperature	-40 to 85°C
Storage Temperature	-55 to 125°C
Package Power Dissipation MSOP8	($T_A = 25^\circ\text{C}$) 500mW

ELECTRICAL CHARACTERISTICS (Cont.) Test Conditions $T_A = 25^\circ\text{C}$, $V_{in} = V_{CC} = 15\text{V}$

SYMBOL	PARAMETER	CONDITIONS	LIMITS			UNIT
			Min	Typ	Max	
Comparator						
V _{comp}	Input Voltage		0.005		10	V
V _H	Hysteresis	$V_{comp_supply} = 5\text{V}$ $R_{comp} = 10\text{k}$		15		mV
I _B	Input Bias	$V_{comp_supply} = 5\text{V}$ $V_{comp_in} = 1\text{V}$ $R_{comp} = 10\text{k}$	5	50	100	nA
T _D	Propagation Delay	$V_{comp_supply} = 5\text{V}$ $R_{comp} = 10\text{k}$		100		ns
V _{OL}	Output Voltage Low	$V_{comp_supply} = 5\text{V}$ $R_{comp} = 10\text{k}$	30	150	200	mV
V _{OH}	Output Voltage High	$V_{comp_supply} = 5\text{V}$ $R_{comp} = 10\text{k}$			V_{comp_supply}	V
I _{OL}	Output Sink Current	$V_{OL} = 0.4\text{V}$	2			mA
I _{OH}	Output High Leakage Current	$V_{comp_supply} = 5\text{V}$ $R_{comp} = 10\text{k}$			1.0	μA
Voltage Reference						
V _{ref}		Reference Current = 0μA	1.200	1.240	1.280	V
		Reference Current = -300μA	1.200	1.240	1.280	V
		Reference Current = +5μA	1.200	1.240	1.280	V
delta V _{ref}	Change in Vref	I _{source} 5μA to I _{sink} 300μA		10		mV
TC				30		ppm/°C
PSR	Supply rejection			0.01		%/V

ZXCT1030

TYPICAL CHARACTERISTICS

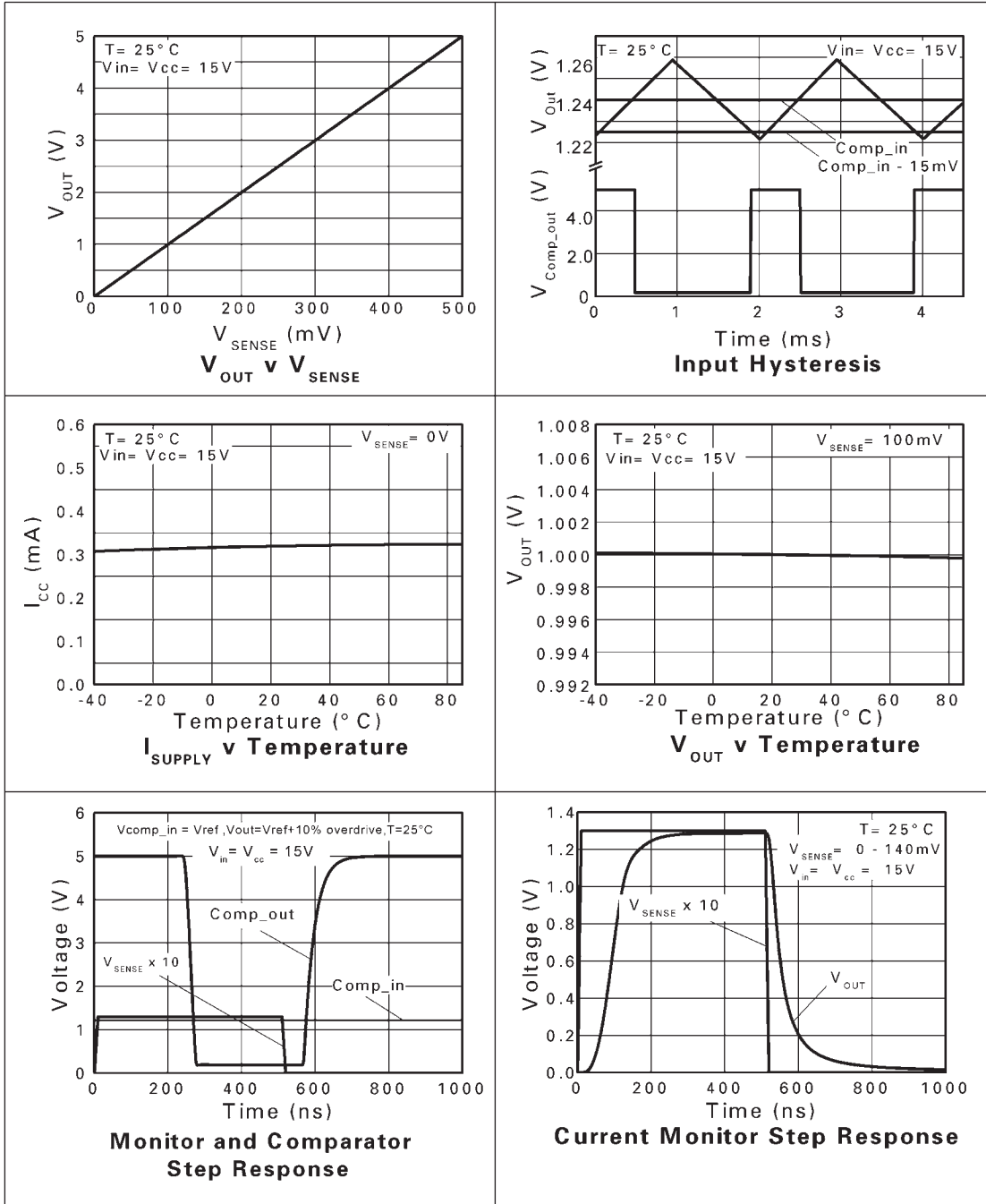

ZXCT1030

Voltage output Current Monitor

Referring to the block diagram, the current monitor takes the small voltage developed across the sense resistor (V_{sense}) and transfers it from the large common mode supply voltage to a ground-referenced signal with a gain of 10. The sense input common mode range is 2.2V to 20V. In this range, a linear output voltage is delivered.

Reference

The bandgap reference allows the comparator to compare the translated V_{sense} with threshold value chosen by the user which can be any voltage from 0 to 1.24V, configured by two external resistors which forms V_{comp_in} .

The output current which can be drawn from the comparator reference (I_{ref} source) is limited to $5\mu A$, making potentiometers $\geq 250k\Omega$ suitable for setting a threshold level. Where a lower potentiometer resistor value is used, an additional resistor value should be inserted between V_{ref} and V_{CC} to maintain sufficient current for the reference. (as shown in figure 1.0).

FIGURE 1.0
External resistor for reference level

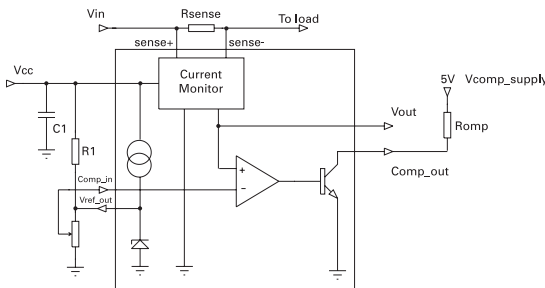

The Voltage reference has a maximum current sink capability. This magnitude of current will be influenced by the value of R_1 which is inserted between V_{ref} and V_{CC} . The value of current flowing through R_1 can be expressed as:

$$I = (V_{CC} - V_{ref}) / R_1$$

Comparator

The open collector output is active low and is asserted when $V_{sense} \times 10 (V_{out}) > V_{comp_in}$.

It can be connected to any voltage rail up to V_{in} via a pull-up resistor. Suggest values for the resistor are in the range of 10-100k Ω .

In the case where high load currents or a short circuit occurs, thus reducing the common mode signals (V_+ , V_-) typically below 2.2V, the comparator will default to the asserted state. This can eliminate a closed loop system 'latch-up' condition, allowing the controller to remove the applied power.

Stability

To ensure stable operation of the ZXCT1030, it is recommended a decoupling capacitor is placed across the V_{CC} and ground connections. A ceramic 10 μF will be adequate.

PIN CONNECTIONS

MSOP8

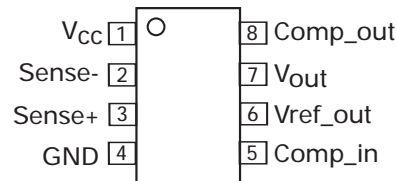

Pin Name	Pin Function
Vcc	Supply voltage
Sense-	Negative sense input
Sense+	Positive sense input
GND	Ground
Comp_in	Comparator input, usually a ratio of the reference or other control signal.
Vref_out	Reference output
Vout	Current Monitor output voltage
Comp_out	Open collector comparator output

ZXCT1030

PACKAGE DIMENSIONS

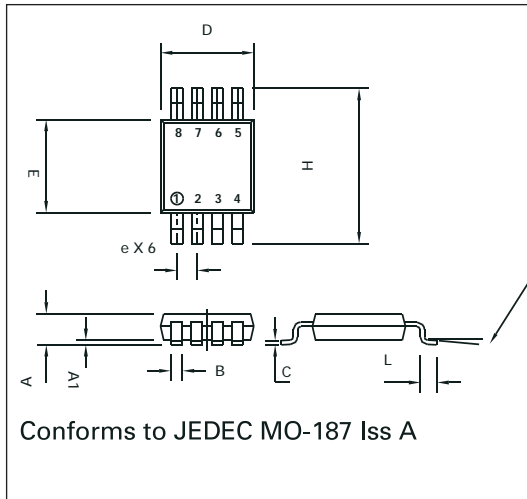

PACKAGE DIMENSIONS

DIM	Millimetres		Inches	
	MIN	MAX	MIN	MAX
A	-	1.10	-	0.043
A1	0.05	0.15	0.002	0.006
B	0.25	0.40	0.010	0.016
C	0.13	0.23	0.005	0.009
D	2.90	3.10	0.114	0.122
e	0.65 BSC		0.0256 BSC	
E	2.90	3.10	0.114	0.122
H	4.90 BSC		0.193 BSC	
L	0.40	0.70	0.016	0.028
°	0°	6°	0°	6°

PAD LAYOUT DETAILS

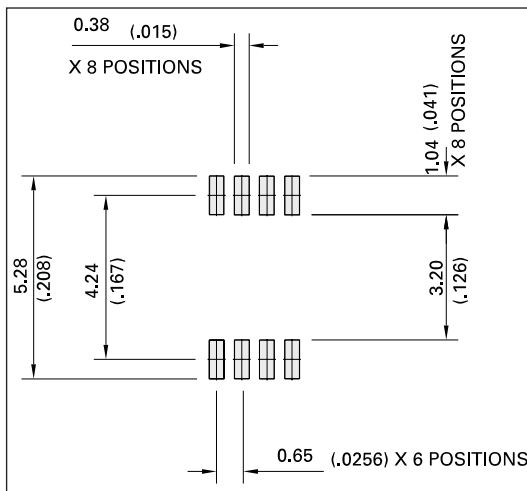

© Zetex Semiconductors plc 2004

Europe	Americas	Asia Pacific	Corporate Headquarters
Zetex GmbH Streitfeldstraße 19 D-81673 München Germany	Zetex Inc 700 Veterans Memorial Hwy Hauppauge, NY 11788 USA	Zetex (Asia) Ltd 3701-04 Metroplaza Tower 1 Hing Fong Road, Kwai Fong Hong Kong	Zetex Semiconductors plc Zetex Technology Park, Chadderton Oldham, OL9 9LL United Kingdom
Telefon: (49) 89 45 49 49 0 Fax: (49) 89 45 49 49 49 europa.sales@zetex.com	Telephone: (1) 631 360 2222 Fax: (1) 631 360 8222 usa.sales@zetex.com	Telephone: (852) 26100 611 Fax: (852) 24250 494 asia.sales@zetex.com	Telephone (44) 161 622 4444 Fax: (44) 161 622 4446 hq@zetex.com

These offices are supported by agents and distributors in major countries world-wide.

This publication is issued to provide outline information only which (unless agreed by the Company in writing) may not be used, applied or reproduced for any purpose or form part of any order or contract or be regarded as a representation relating to the products or services concerned. The Company reserves the right to alter without notice the specification, design, price or conditions of supply of any product or service.

For the latest product information, log on to www.zetex.com



PROVISIONAL ISSUE J - MAY 2004

Copyright © Each Manufacturing Company.

All Datasheets cannot be modified without permission.

This datasheet has been download from :

www.AllDataSheet.com

100% Free DataSheet Search Site.

Free Download.

No Register.

Fast Search System.

www.AllDataSheet.com