

# SAW Bandpass Filter 206139B

## 1. Features

- IF Bandpass Filter
- Low-Loss Filter
- Single-Ended Operation
- Ceramic Surface Mount Device (SMD) Package
- Maximum Storage Temperature Range : -40 °C ~ 85 °C
- Electrostatics Sensitive Device (ESD)

## 2. Package Dimensions

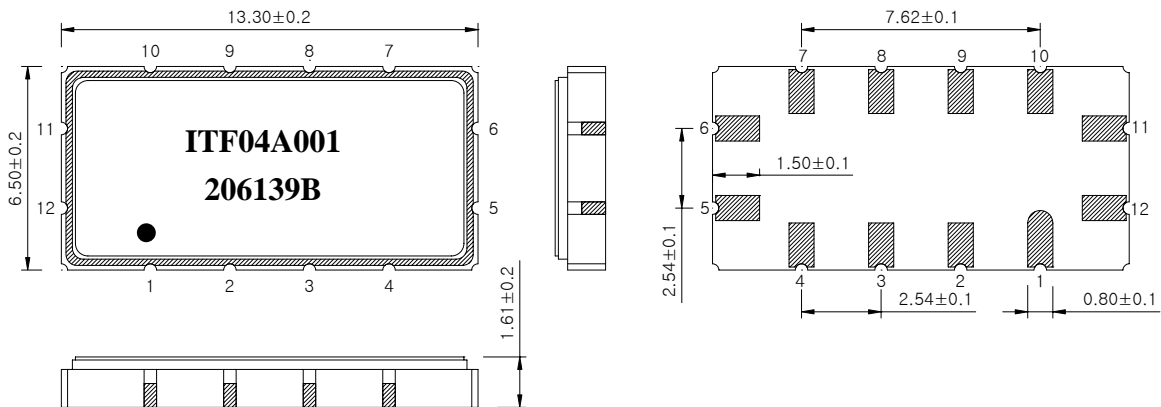

**Package : S1365**

Dimensions shown are nominal in millimeters

Body : Al<sub>2</sub>O<sub>3</sub> Ceramic

Lid : Kovar, Ni Plated

Terminations : Au plating 0.3 ~ 1.0 um, Over a 1.27 ~ 8.89 um Ni Plating

Pad Configuration	
11	Input
5	Output
6, 12	Ground
Other	Case ground



**ITF Co., Ltd.**  
 102-901, Bucheon Technopark 364,  
 Samjeong-Dong, Ojeong-Gu, Bucheon-City,  
 Gyeonggi-Do, Korea 421-809

Part No.	206139B	
Rev. Date	2004-04-29	
Rev.	NI0036-CS03	1/5

## SAW Bandpass Filter 206139B

### 3. Specifications

Fo = 70.0 MHz

Terminating source impedance : 50Ω and matching network

Terminating load impedance : 50Ω and matching network

		Minimum	Typical	Maximum
Center Frequency	MHz	69.8	70.0	70.2
Insertion Loss	dB	-	11.0	13.0
1dB Bandwidth	MHz	8.5	8.7	-
3dB Bandwidth	MHz	9.25	9.3	-
40dB Bandwidth	MHz	-	11.5	11.8
Amplitude Ripple (Fo +/- 4.0 MHz)	dB	-	0.6	1.0
Group Delay Variation (Fo +/- 4.0 MHz)	nsec	-	70	120
Absolute Delay	Usec	-	1.47	-
Ultimate Rejection	dB	40	45	-
Temperature Coefficient of Frequency	ppm/°C	-	-86	-

#### Notes :

- 1) All specifications are based on the matching schematic shown below
- 2) All specifications are measured by Agilent Network analyzer and full 2 port calibration at room temperature
- 3) All attenuation measurements are measured relative to insertion loss

 Integrated Technology Future	<b>ITF Co., Ltd.</b> 102-901, Bucheon Technopark 364, Samjeong-Dong, Ojeong-Gu, Bucheon-City, Gyeonggi-Do, Korea 421-809	Part No.	206139B	
		Rev. Date	2004-04-29	
		Rev.	NI0036-CS03	2/5

# SAW Bandpass Filter 206139B

## 4. Matching Schematic

( Actual matching values may vary due to PCB layout and parasitics )

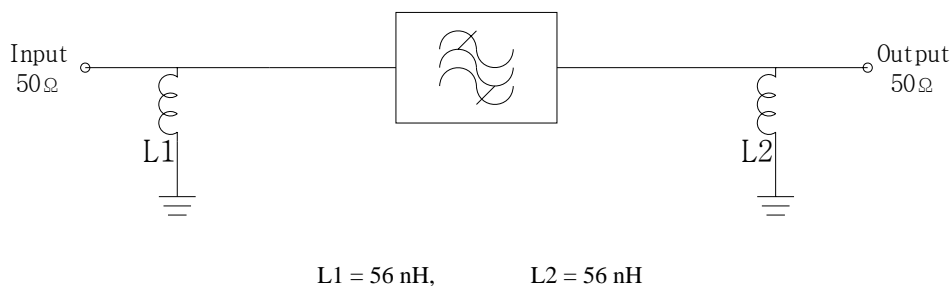

## 5. Marking Configuration

ITF<sup>1)</sup>04A001<sup>2)</sup>

206139B<sup>3)</sup>

●<sup>4)</sup>

1) Manufacturer name

2) Lot Number

3) Part Number

4) Pad Number 1 Index

	<b>ITF Co., Ltd.</b> 102-901, Bucheon Technopark 364, Samjeong-Dong, Ojeong-Gu, Bucheon-City, Gyeonggi-Do, Korea 421-809	Part No.	206139B	
		Rev. Date	2004-04-29	
		Rev.	NI0036-CS03	3/5

# SAW Bandpass Filter 206139B



## 6. Typical Performance ( at +25°C )

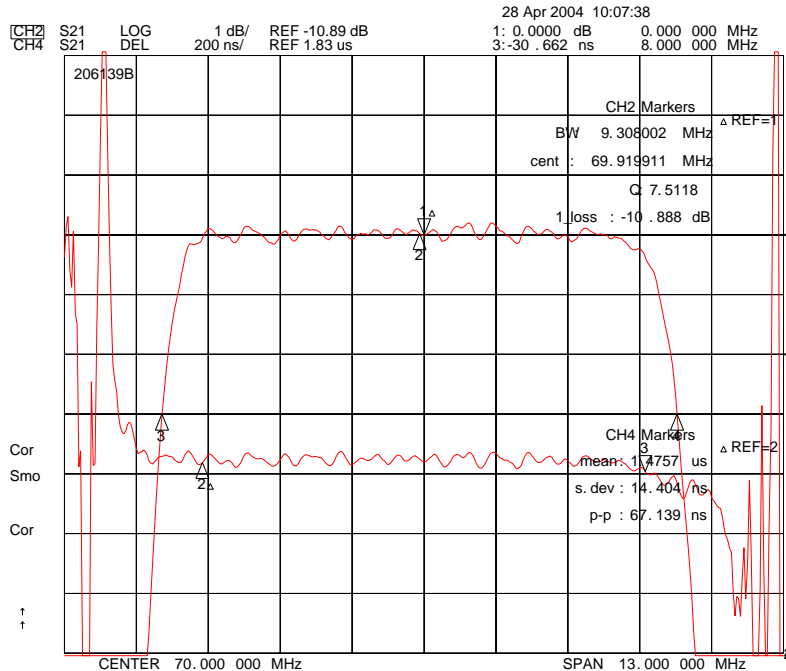
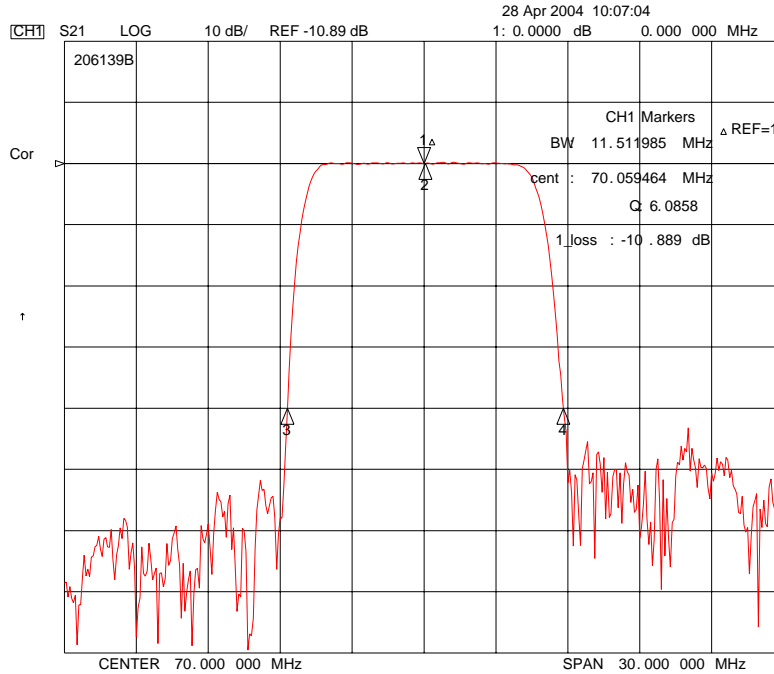

	<b>ITF Co., Ltd.</b> 102-901, Bucheon Technopark 364, Samjeong-Dong, Ojeong-Gu, Bucheon-City, Gyeonggi-Do, Korea 421-809	Part No.	206139B	
		Rev. Date	2004-04-29	
		Rev.	NI0036-CS03	4/5

# SAW Bandpass Filter 206139B

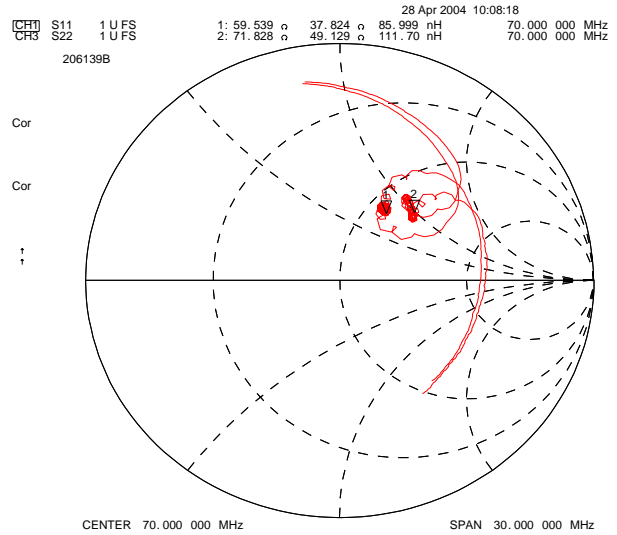
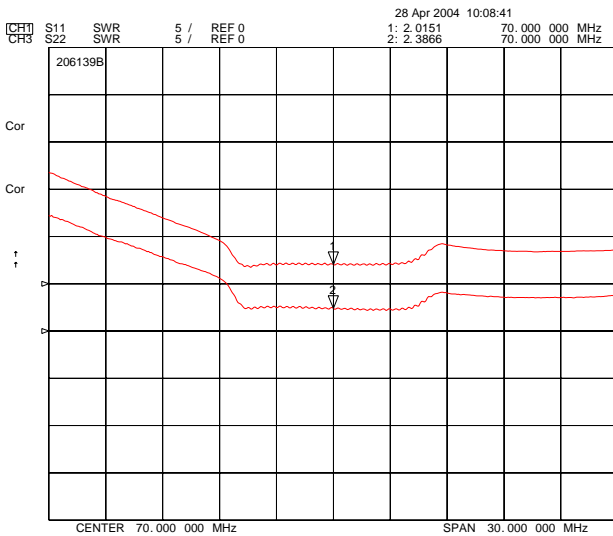
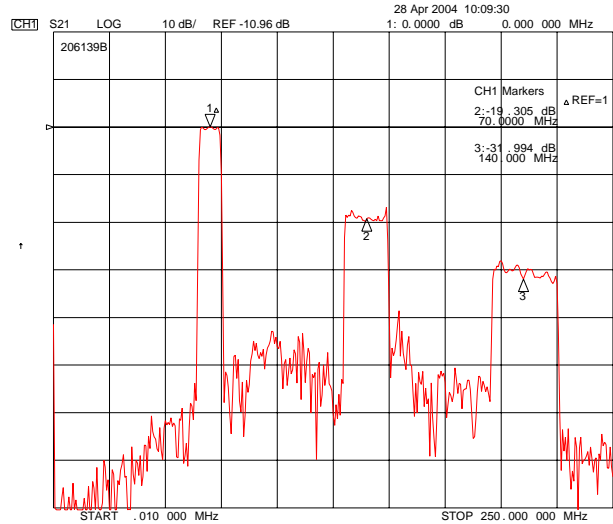
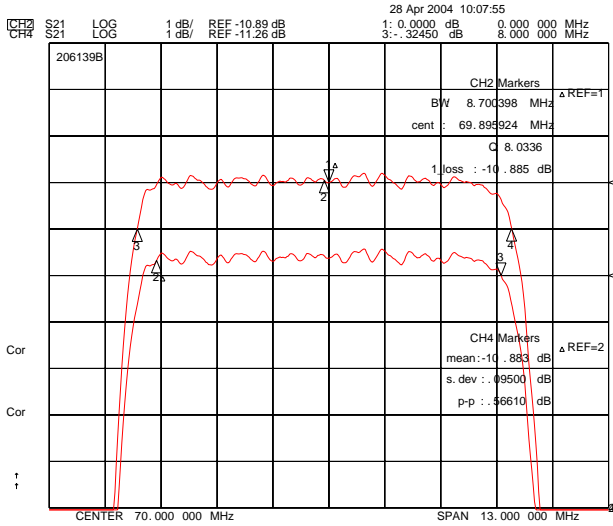

	<p align="center"><b>ITF Co., Ltd.</b>                  102-901, Bucheon Technopark 364,                  Samjeong-Dong, Ojeong-Gu, Bucheon-City,                  Gyeonggi-Do, Korea 421-809</p>	Part No.	206139B	
		Rev. Date	2004-04-29	
		Rev.	NI0036-CS03	5/5