

[查询"NJM2258L"供应商](#)

VIDEO EQUALIZER

■ GENERAL DESCRIPTION

NJM2258 is the IC functioning the gain high pass correction, as well as for equalizing function of wave distortion correction, generated by bright signal of group delay feature like low band filter. It has internalizing REC line, one circuit, and then the playback line 2 circuit.

■ PACKAGE OUTLINE

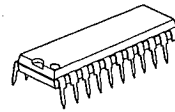

NJM2258L

■ FEATURES

- 5V Spec, (Recommended Operating Voltage Range)
- Wide Band Width, 10MHz
- REC/PLAYBCK Change over function attached
- Package Outline SDIP22
- Bipolar Technology

■ Application

- VCR (S-VHS compatible)
- Video Camera
- Laser Disc

■ BLOCK DIAGRAM

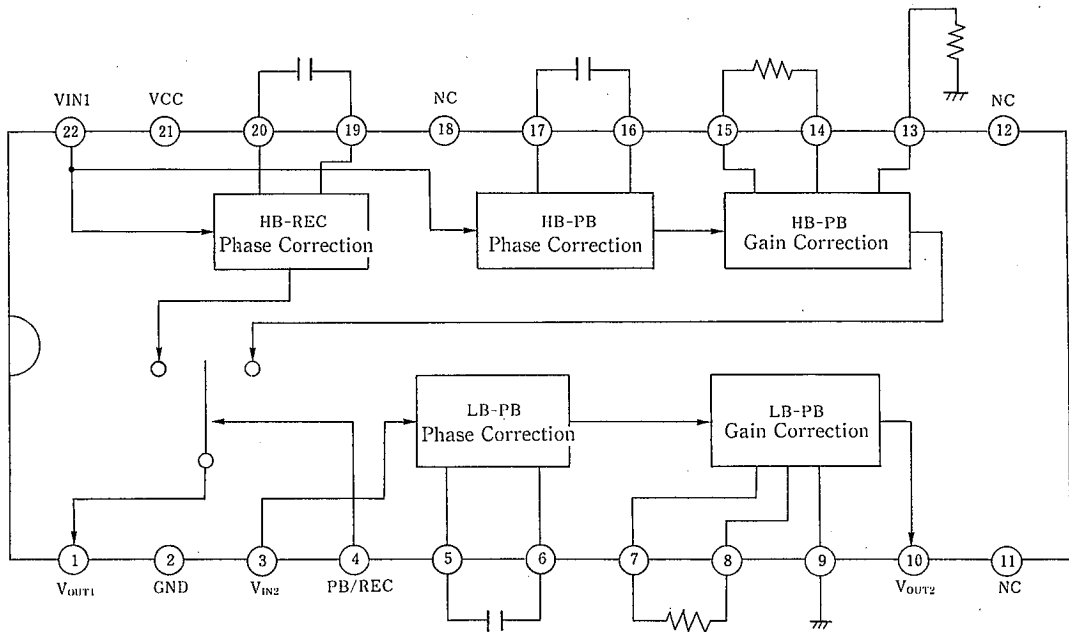

[查询"NJM2258L"供应商](#)

■ ABSOLUTE MAXIMUM RATINGS

(Ta=25°C)

PARAMETER	SYMBOL	RATINGS	UNIT
Supply Voltage	V ⁺	7	V
Power Dissipation	P _D	700	mW
Operating Temperature Range	T _{opr}	-20~+75	°C
Storage Temperature Range	T _{stg}	-40~+125	°C

■ ELECTRICAL CHARACTERISTICS

(V⁺=5V, Ta=25°C)

PARAMETER	SYMBOL	TEST CONDITION	MIN.	TYP.	MAX.	UNIT
Operating Current	I _p	No Signal		26	34	mA

HB-REC

Phase Positive Gain	G _{af}	f _{IN} =100KHz 19PINOUT	-1	0	+1	dB
Phase Negative Gain	G _{ar}	f _{IN} =100KHz 20PINOUT	-6.4	-5.4	-4.4	dB
19pin Impedance	AT19	f _{IN} =100KHz	-7.0	-6.0	-5.0	dB
Output Gain LOW	G _{al}	f _{IN} =100kHz	-1	0	+1	dB
Output Gain HIGH	G _{ah}	f _{IN} =5MEGHZ	-1	0	+1	dB
Output Gain f Feature	ΔG _{ai}	G _{ah} -G _{al}	-1	0	+1	dB
Output Secondary Distortion	DA2	f _{IN} =5MEG v _{IN} =1.0V _{pp}		-40	-30	dB
Output the third Distortion	DA3	f _{IN} 5MEG v _{IN} =1.0V _{pp}		-36	-30	dB

HB-PB

Positiv Phase Gain	G _{br}	f _{IN} =100KHz 16PINOUT	-1	0	+1	dB
Negative Phase Gain	G _{br}	f _{IN} =100KHz 17PINOUT	-0.2	0.8	1.8	dB
16 Impedance	AT16	f _{IN} =100KHz	-7.0	-6.0	-5.0	dB
Output Gain	G _{ca}	f _{IN} =100KHz	-6.1	-5.0	-4.0	dB
15-14 Impedance	ΔG _c	15PIN-14PIN=1.7KΩ	4.5	5.5	6.5	dB
Output Gain LOW	G _{cbi}	f _{IN} =100KHz	-1	0	+1	dB
Output Gain HIGH	G _{cbh}	f _{IN} =5MEGHZ	2	3	4	dB
Output Gain f Feature	ΔG _b	G _{cbh} -G _{cbi}	2	3	4	dB
Output Secondary Distortion	DC2	f _{IN} =5MEG v _{IN} =1.0V _{pp}		-30	-25	dB
Output the third Distortion	DC3	f _{IN} =5MEG v _{IN} =1.0V _{pp}		-27	-22	dB

LB-PB

Positive Phase Gain	D _{af}	f _{IN} =100KHz 6PINOUT	-1	0	+1	dB
Negative Phase Gain	G _{dr}	f _{IN} =100KHz 5PINOUT	-0.2	0.8	1.8	dB
6 Impedance	AT6	f _{IN} =100KHz	-7.0	-6.0	-5.0	dB
Output Gain	G _{da}	f _{IN} =100KHz	-6.1	-5.1	-4.1	dB
7-8 Impedance	ΔG _d	7PIN-8PIN=1.7KΩ	4.5	5.5	6.5	dB
Output Gain LOW	G _{ebi}	f _{IN} =100KHz		+1	0	dB
Output Gain HIGH	G _{ebh}	f _{IN} =5MEGHZ	-1	0	+1	dB
Output Gain f Feature	ΔG _e	G _{ebh} -G _{ebi}	-1	0	+1	dB
Output Secondary Distortion	DE2	f _{IN} =5MEG v _{IN} =1.0V _{pp}		-35	-28	dB
Output the third Distortion	DE3	f _{IN} =5MEG v _{IN} =1.0V _{pp}		-36	-30	dB

[查询"NJM2258L"供应商](#)

■ TERMINAL FUNCTION

PIN	PIN NAME	SYMBOL	FUNCTION
1	HB-REC/PB OUT	VOUT1	HB type (S-VHS) Correction Output Pin
2	GND	GND	Ground
3	LB-PB IN	VIN2	LB type, (VHS) play-back signal Input Pin
4	HB-REC/PB Change over	PB REC	HB type, Change-over output of REC signal or Play-back signal High makes play-back signal output, and low makes REC signal output.
5	LB-PB Phase Correction Pin 1	LPC1	Connecting Capacitor between Pin 5~6, which helps to give feature of correcting the group delay.
6	LB-PB Phase Correction Pin 2	LPC2	Connecting Capacitor between Pin 5~6, which helps to give feature of correcting the group delay.
7	LB-PB Gain Correction Pin 1	LGC1	Setting up Gain by connecting resistor between Pin 7~8.
8	LB-PB Gain Correction Pin 2	LGC2	Setting up Gain by connecting resistor between Pin 7~8.
9	LB-PB Gain Correction Pin 3	LP	Connecting L-C parallel resonance between pin 9~GND, helps to give High band keeping, and if not required of keeping connect to GND.
10	LB-PB OUT	VOUT2	LB type Output pin
11	N.C		N.C pin
12	N.C		N.C pin
13	LB-PB Gain Correction Pin 3	HP	Connecting L-C parallel resonance between pin 13~GND, helps to give High band keeping, and if not required of keeping connect to GND.
14	LB-PB Gain Correction Pin 2	HPG1	Setting up Gain by connecting resistor between Pin 14~15.
15	LB-PB Gain Correction Pin 1	HPG2	Setting up Gain by connecting resistor between Pin 14~15.
16	LB-PB Phase Correction Pin 2	HPC1	Connecting Capacitor between Pin 16~17, which helps to give feature of correcting the group delay.
17	LB-PB Phase Correction Pin 1	HPC2	Connecting Capacitor between Pin 16~17, which helps give feature of correcting the group delay.
18	N.C		N.C pin
19	LB-PB Phase Correction Pin 2	HRC1	Connecting Capacitor between Pin 19~20, which helps to give feature of correcting the group delay.
20	LB-PB Phase Correction Pin 1	HRC2	Connecting Capacitor between Pin 19~20, which helps to give feature of correcting the group delay.
21	V+	V _{CC}	Voltage Source.
22	HB-REC/PB IN		HB type Input pin.

5

[查询"NJM2258L"供应商](#)

■ TEST CONDITION

PARAMETER	SW-CONDITION													TEST PIN	TEST CONDITION
	1	2	3	4	5	6	7	8	9	10	11	12	13		
I _r	a	a	b	b	b	a	b	b	b	b	b	b	a		
GAf	b													V19	f=100kHz, V=0.5V _{PP}
GAr													b	V20	f=100kHz, V=0.5V _{PP}
AT19											a		a	V19	f=100kHz, V=0.5V _{PP}
Gal											b	a		VOUT1	f=100kHz, V=0.5V _{PP}
Gah											b	a		VOUT1	f=5MHz, V=0.5V _{PP}
DA2													c	VOUT1	f=5MHz, V=1.0V _{PP}
DA3													c	VOUT1	f=5MHz, V=1.0V _{PP}
Gbf														V16	f=100kHz, V=0.5V _{PP}
Gbr														V17	f=100kHz, V=0.5V _{PP}
AT16										a				V16	f=100kHz, V=0.5V _{PP}
Gea	a								a	b				VOUT1	f=100kHz, V=0.5V _{PP}
△Gca							a	a						VOUT1	f=100kHz, V=0.5V _{PP}
Geb1					a		c	c						VOUT1	f=100kHz, V=0.5V _{PP}
Gebh					a		c	c						VOUT1	f=5MHz, V=0.5V _{PP}
DC2					b		c	c	c					VOUT1	f=5MHz, V=1.0V _{PP}
DC3					b		c	c	c					VOUT1	f=5MHz, V=1.0V _{PP}
Gdf	a										b	a		V6	f=100kHz, V=0.5V _{PP}
Gdr														V5	f=100kHz, V=0.5V _{PP}
AT6		b												V6	f=100kHz, V=0.5V _{PP}
Gda		a												VOUT2	f=100kHz, V=0.5V _{PP}
△Gd			a	a										VOUT2	f=100kHz, V=0.5V _{PP}
Geb1			c	c										VOUT2	f=100kHz, V=0.5V _{PP}
Gebh			c	c										VOUT2	f=5MHz, V=0.5V _{PP}
DE2			c	c										VOUT2	f=5MHz, V=1.0V _{PP}
DE3			c	c										VOUT2	f=5MHz, V=1.0V _{PP}

5

查询"NJM2258L"供应商

■ TEST CIRCUIT

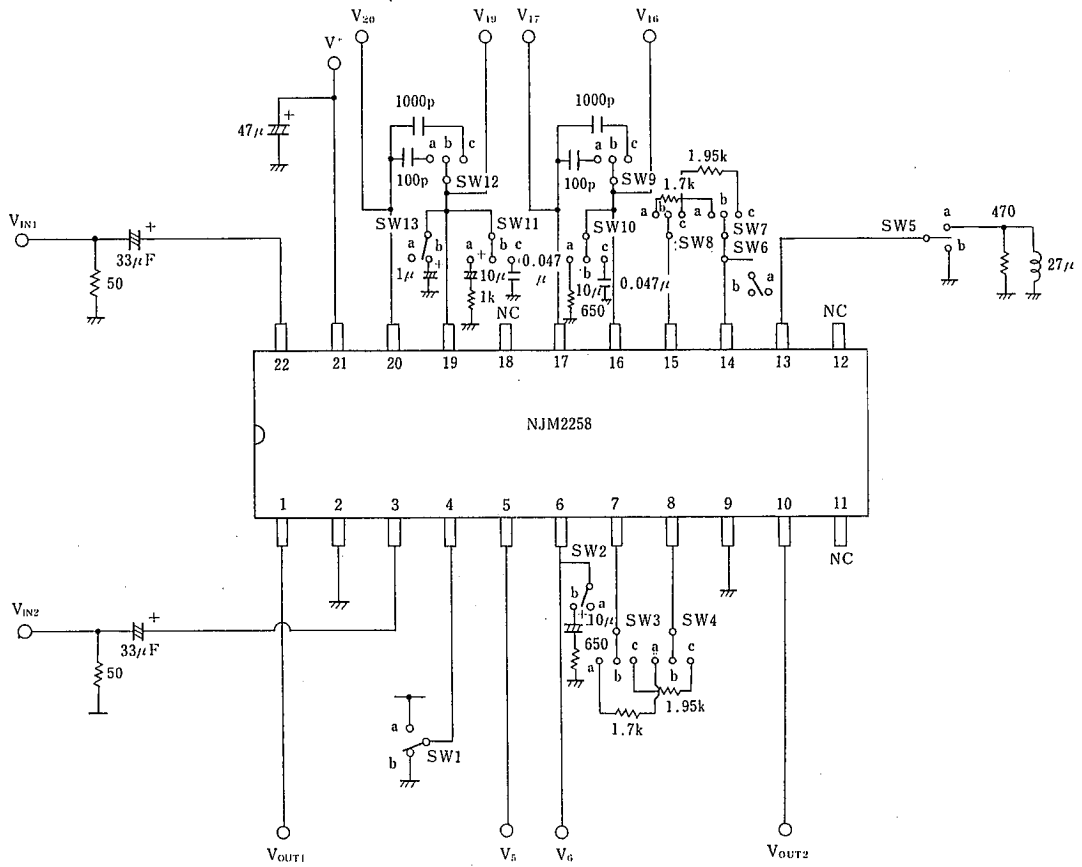

5

[查询"NJM2258L"供应商](#)

APPLICATION CIRCUIT

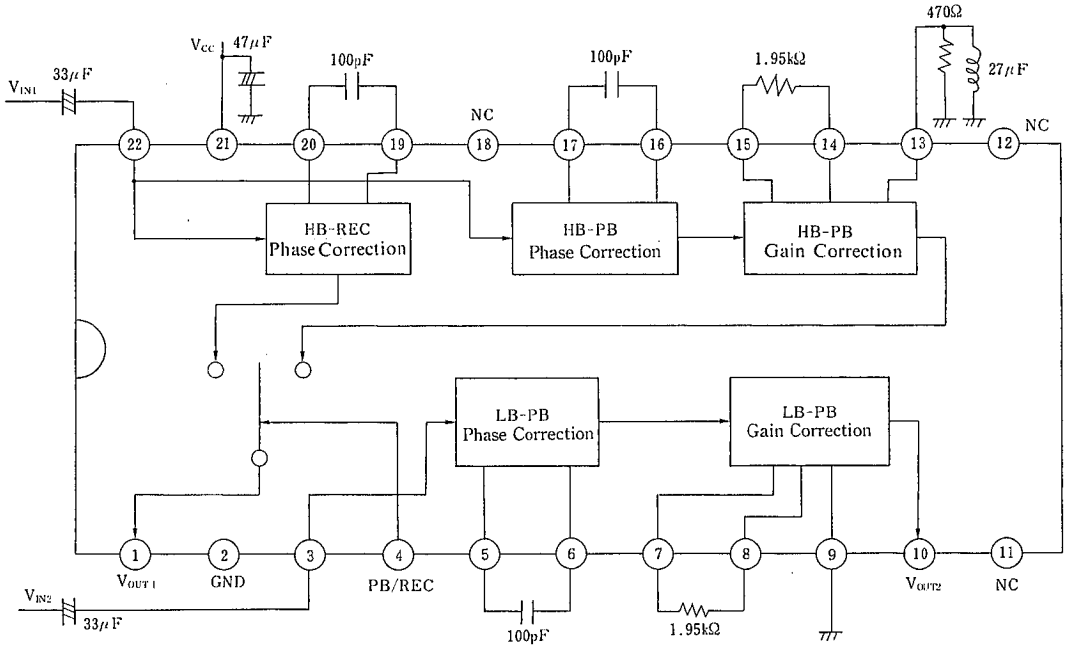

5

NJM2258

[查询"NJM2258L"供应商](#)

MEMO

[CAUTION]

The specifications on this databook are only given for information , without any guarantee as regards either mistakes or omissions. The application circuits in this databook are described only to show representative usages of the product and not intended for the guarantee or permission of any right including the industrial rights.