

# LM8333

## Mobile I/O Companion Supporting Key-Scan, I/O Expansion, PWM, and ACCESS.bus Host Interface

### 1.0 General Description

The LM8333 Mobile I/O Companion offloads the burden of keyboard scanning from the host, while providing extremely low power consumption in both operational and standby modes. It supports keypad matrices up to 8 × 8 in size (plus another 8 special-function keys), for portable applications such as cellphones, PDAs, games, and other handheld applications.

Key press and release events are encoded into a byte format and loaded into a FIFO buffer for retrieval by the host processor. An interrupt output (IRQ) is used to signal events such as keypad activity, a state change on either of two interrupt-capable general-purpose I/O pins, or an error condition. Interrupt and error codes are available to the host by reading dedicated registers.

Four general-purpose I/O pins are available, two of which have interrupt capability. A pulse-width modulated output based on a host-programmable internal timer is also available, which can be used as a general-purpose output if the PWM function is not required.

To minimize power, the LM8333 automatically enters a low-power standby mode when there is no keypad, I/O, or host activity.

The device is packaged in a 32-pin Leadless Leadframe package (LLP) and a 49-pin MICRO-ARRAY. Both are chip-scale packages.

### 2.0 Features

- 8 × 8 standard keys
- 8 special function keys (SF keys) providing a total of 72 keys for the maximum keyboard matrix
- ACCESS.bus (I<sup>2</sup>C-compatible) communication interface to the host
- Four general purpose host programmable I/O pins with two optional (slow) external Interrupts
- 16 byte FIFO buffer to store key pressed and key released events
- Error control with error reports on (FIFO overrun, Keypad overrun, invalid command)
- Host programmable PWM
- Host programmable active time and debounce time

### 3.0 Applications

- Mobile phones
- Personal Digital Assistants (PDAs)
- Smart handheld devices
- Personal media players

### 4.0 Block Diagram

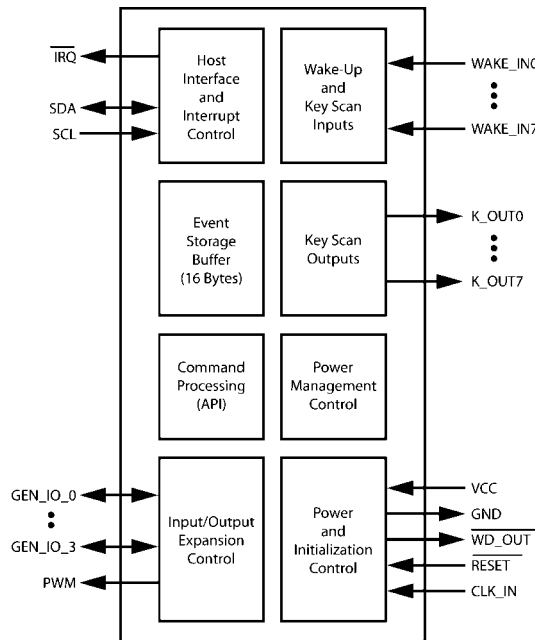

20210601

I<sup>2</sup>C® is a registered trademark of Phillips Corporation.

## 5.0 Ordering Information

查询"LM8333FLQ8Y"供应商

NSID	Spec.	No. of Pins	Package Type	Temperature	Package Method
LM8333FLQ8X	NOPB	32	LLP	-40 to + 85°C	2500 pcs Tape & Reel
LM8333FLQ8Y	NOPB	32	LLP	-40 to + 85°C	250 pcs Tape & Reel
LM8333GGR8	NOPB	49	Micro-array	-40 to + 85°C	1000 pcs Tape & Reel

NOPB = No PB (No Lead)

## 6.0 Pin Assignments

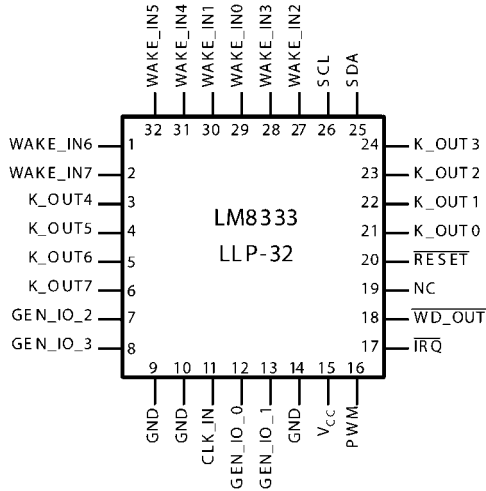

20210649

**Top View**  
**Leadless Leadframe Package**  
See NS Package Number LQA32A

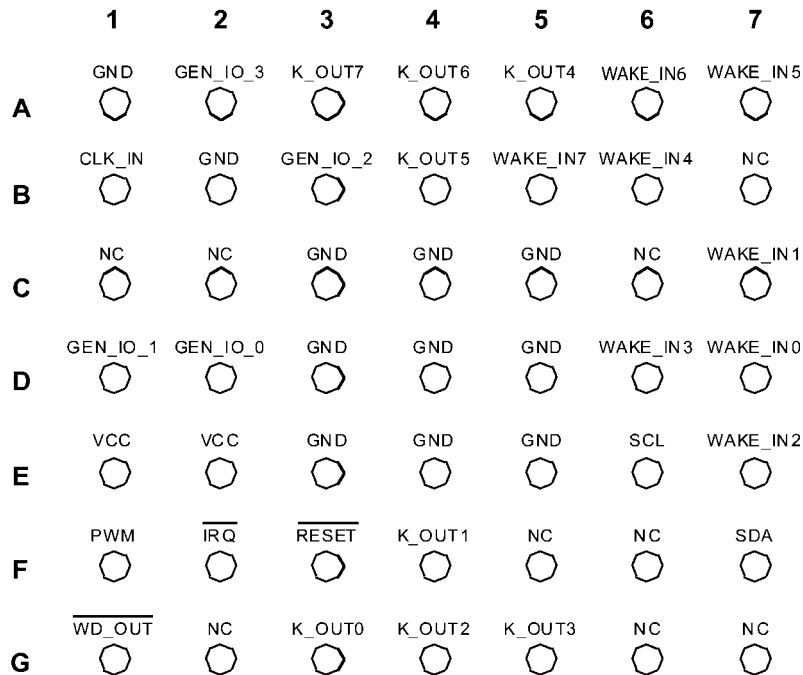

20210602

**Top View**  
**MICRO-ARRAY Package**  
See NS Package Number GRA49A

## Table of Contents

<a href="#">查询"LM8333FLQ8Y"供应商</a>	
1.0 General Description .....	1
2.0 Features .....	1
3.0 Applications .....	1
4.0 Block Diagram .....	1
5.0 Ordering Information .....	2
6.0 Pin Assignments .....	2
7.0 Signal Descriptions .....	4
8.0 Typical Application .....	5
8.1 FEATURES .....	5
8.2 I/O EXPANSION OPTIONS .....	5
8.3 WATCHDOG TIMER .....	5
8.4 HALT MODE .....	5
8.4.1 ACCESS.bus Activity .....	5
8.5 KEYPAD SCANNING .....	6
8.6 COMMUNICATION INTERFACE .....	6
8.6.1 Interrupts Between the Host and LM8333 .....	6
8.6.2 Interrupt Sources .....	6
9.0 Device Operation .....	6
9.1 EVENT CODE ASSIGNMENT .....	6
9.2 I/O EXPANSION .....	7
9.2.1 PWM Output with Programmable Duty Cycle .....	7
9.2.2 General-Purpose I/O (GPIO) .....	8
9.2.3 External Interrupts .....	8
9.3 HOST COMMAND EXECUTION .....	9
9.3.1 Command Structure .....	9
9.4 HOST WRITE COMMANDS .....	10
9.5 HOST READ COMMANDS .....	10
9.6 WAKE-UP FROM HALT MODE .....	11
10.0 Interrupts .....	11
10.1 INTERRUPT CODE .....	11
10.2 ERROR CODE .....	11
10.3 STATUS CODES .....	12
10.4 INTERRUPT PROCESSING .....	12
10.5 COMMAND EXECUTION SUMMARY .....	13
11.0 Absolute Maximum Ratings .....	14
12.0 DC Electrical Characteristics .....	14
13.0 AC Electrical Characteristics .....	15
14.0 Physical Dimensions .....	17

## 7.0 Signal Descriptions

[查询"LM8333FLQ8Y"供应商](#)

Name	32 Pins	49 Pins	I/O	Description
WAKE_IN0	29	D7	Input	Wake-up input/Keyboard scanning input 0
WAKE_IN1	30	C7	Input	Wake-up input/Keyboard scanning input 1
WAKE_IN2	27	E7	Input	Wake-up input/Keyboard scanning input 2
WAKE_IN3	28	D6	Input	Wake-up input/Keyboard scanning input 3
WAKE_IN4	31	B6	Input	Wake-up input/Keyboard scanning input 4
WAKE_IN5	32	A7	Input	Wake-up input/Keyboard scanning input 5
WAKE_IN6	1	A6	Input	Wake-up input/Keyboard scanning input 6
WAKE_IN7	2	B5	Input	Wake-up input/Keyboard scanning input 7
K_OUT0	21	G3	Output	Keyboard scanning output 0
K_OUT1	22	F4	Output	Keyboard scanning output 1
K_OUT2	23	G4	Output	Keyboard scanning output 2
K_OUT3	24	G5	Output	Keyboard scanning output 3
K_OUT4	3	A5	Output	Keyboard scanning output 4
K_OUT5	4	B4	Output	Keyboard scanning output 5
K_OUT6	5	A4	Output	Keyboard scanning output 6
K_OUT7	6	A3	Output	Keyboard scanning output 7
GEN_IO_0	12	D2	I/O	General-purpose I/O 0
GEN_IO_1	13	D1	I/O	General-purpose I/O 1
GEN_IO_2	7	B3	I/O	General-purpose I/O 2
GEN_IO_3	8	A2	I/O	General-purpose I/O 3
SDA	25	F7	I/O	ACCESS.bus data signal
SCL	26	E6	Input	ACCESS.bus clock signal
IRQ	17	F2	Output	Interrupt request output
PWM	16	F1	Output	Pulse-width modulated output
WD_OUT	18	G1	Output	Watchdog timer output (connect to RESET input)
RESET	20	F3	Input	Reset input
CLK_IN	11	B1	Input	Clock input (connect to ground through a 68k ohm resistor)
VCC	15	E1, E2	n.a.	Vcc
GND	9, 10, 14	A1, B2, C3, C4, C5, D3, D4, D5, E3, E4, E5	n.a.	Ground
NC	19	B7, C1, C2, C6, F5, F6, G2, G6, G7	n.a.	No connect

## 8.0 Typical Application

[查询"LM8333FLQ8Y"供应商](#)

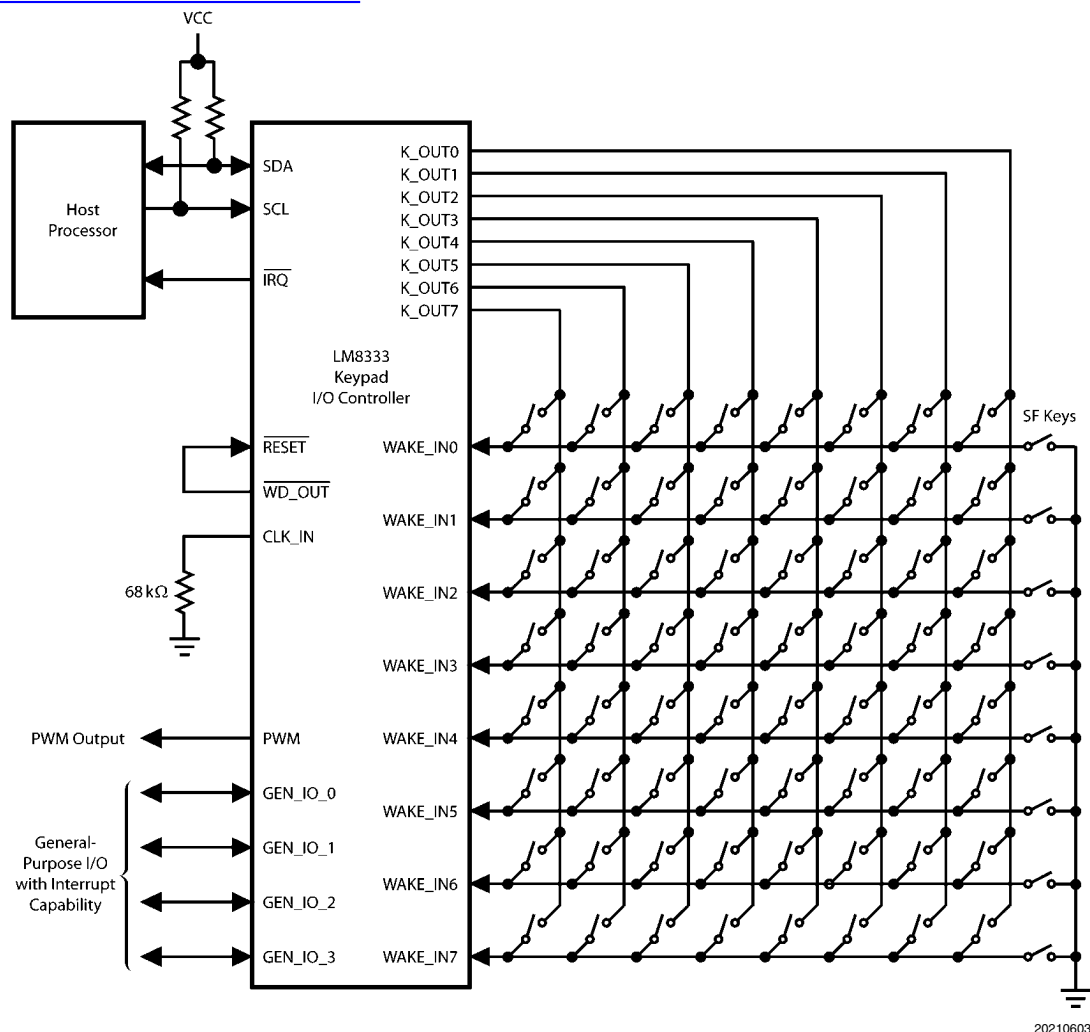

20210603

FIGURE 1. Typical Keypad Configuration

### 8.1 FEATURES

The following features are supported:

- 8 x 8 standard keys.
- 8 special function keys (SF keys) with wake-up capability by forcing a WAKE\_INx pin to ground. Pressing a SF key overrides any other key in the same row.
- A total of 72 keys can be scanned.
- ACCESS.bus (I<sup>2</sup>C-compatible) interface for communication with the host.
- The watchdog timer is mandatory, so  $\overline{\text{WD\_OUT}}$  must be connected to  $\overline{\text{RESET}}$ .

### 8.2 I/O EXPANSION OPTIONS

- One host-programmable PWM output which also may be used as a general-purpose output.
- Four host-programmable general-purpose I/O pins, GEN\_IO\_0, GEN\_IO\_1, GEN\_IO\_2, and GEN\_IO\_3. GEN\_IO\_0 and GEN\_IO\_1 can also be configured for "slow" interrupts, in which any transition will trigger a hardware interrupt event to the host.

### 8.3 WATCHDOG TIMER

The watchdog timer is always enabled in hardware. To use the timer, connect the  $\overline{\text{WD\_OUT}}$  output to the  $\overline{\text{RESET}}$  input.

### 8.4 HALT MODE

The fully static architecture of the LM8333 allows stopping the internal RC clock in Halt mode, which reduces power consumption to the minimum level.

Halt mode is entered when no key-press, key-release, or ACCESS.bus activity is detected for a certain period of time (by default, 500 milliseconds). The mechanism for entering Halt mode is always enabled in hardware, but the host can program the period of inactivity which triggers entry into Halt mode.

The LM8333 will remain in Active mode as long as a key event, or any other event, which causes the  $\overline{\text{IRQ}}$  output to be asserted is not resolved.

#### 8.4.1 ACCESS.bus Activity

When the LM8333 is in Halt mode, any activity on the ACCESS.bus interface will cause the LM8333 to exit from Halt mode. However, the LM8333 will not be able to acknowl-

edge the first bus cycle immediately following wake-up from Halt mode. It will respond with a negative acknowledgement, and the host should then repeat the cycle.

The LM8333 will be prevented from entering Halt mode if it shares the bus with peripherals that are continuously active. For lowest power consumption, the LM8333 should only share the bus with peripherals that require little or no bus activity after system initialization.

### 8.5 KEYPAD SCANNING

The LM8333 starts new scanning cycles at fixed time intervals of about 4 ms. If a change in the state of the keypad is detected, the keypad is rescanned after a debounce delay. When the state change has been reliably captured, it is encoded and written to the FIFO buffer.

If more than two keys are pressed simultaneously, the pattern of key closures may be ambiguous, so pressing more than two keys asserts the Error Flag condition and the  $\overline{\text{IRQ}}$  output (if enabled). The host may attempt to interpret the events stored in the FIFO or discard them.

The SF keys connect the WAKE\_INx pins directly to ground. There can be up to eight SF-keys. If any of these keys are pressed, other key presses that use the same WAKE\_INx pin will be ignored.

### 8.6 COMMUNICATION INTERFACE

The two-wire ACCESS.bus interface is used to communicate with a host. The ACCESS.bus interface is fully compliant with the I<sup>2</sup>Cbus standard. The LM8333 operates as a bus slave at speeds up to 400 kHz.

An ACCESS.bus transfer starts with a byte that includes a 7-bit slave device address. The LM8333 responds to a fixed device address. This address is 0xA2, when aligned to the MSB (7-bit address mapped to bits 7:1, rather than bits 6:0). Bit 0 is a direction bit (0 on write, 1 on read).

Because it is a slave, the LM8333 never initiates an ACCESS.bus cycle, it only responds to bus cycles initiated by

the host. The LM8333 may signal events to the host by asserting the  $\overline{\text{IRQ}}$  interrupt request.

#### 8.6.1 Interrupts Between the Host and LM8333

The  $\overline{\text{IRQ}}$  output is used to signal unresolved interrupts, errors, and key-events to the host.

The host can use an available GEN\_IO\_0 or GEN\_IO\_1 pin to interrupt (or wake-up) the LM8333, if it is not being used for another function. The host can also wake-up the LM8333 by sending a Start Condition on the ACCESS.bus interface.

**Note:** The LM8333 it will not be able to acknowledge the first byte received from the host after wake-up. In this case, the host will have to resend the slave address.

#### 8.6.2 Interrupt Sources

The  $\overline{\text{IRQ}}$  output is asserted on these conditions:

- Any new key-event.
- Any error condition, which is indicated by the error code.
- Any enabled interrupt on either of the GEN\_IO\_0 or GEN\_IO\_1 pins that can be configured as external interrupt inputs. When enabled, any rising or falling edge triggers an interrupt.

The  $\overline{\text{IRQ}}$  output remains asserted until the interrupt code is read.

## 9.0 Device Operation

### 9.1 EVENT CODE ASSIGNMENT

After power-on reset, the LM8333 starts scanning the keypad. It stays active for a default time of about 500 ms after the last key is released, after which it enters a standby mode to minimize power consumption (<2  $\mu\text{A}$  standby current).

*Table 1* lists the codes assigned to the matrix positions encoded by the hardware. Key-press events are assigned the codes listed in *Table 1*, but with the MSB set. When a key is released, the MSB of the code is clear.

**TABLE 1. Keypad Matrix Code Assignments**

	K_OUT0	K_OUT1	K_OUT2	K_OUT3	K_OUT4	K_OUT5	K_OUT6	K_OUT7	SF Keys
WAKE_IN0	0x01	0x02	0x03	0x04	0x05	0x06	0x07	0x08	0x09
WAKE_IN1	0x11	0x12	0x13	0x14	0x15	0x16	0x17	0x18	0x19
WAKE_IN2	0x21	0x22	0x23	0x24	0x25	0x26	0x27	0x28	0x29
WAKE_IN3	0x31	0x32	0x33	0x34	0x35	0x36	0x37	0x38	0x39
WAKE_IN4	0x41	0x42	0x43	0x44	0x45	0x46	0x47	0x48	0x49
WAKE_IN5	0x51	0x52	0x53	0x54	0x55	0x56	0x57	0x58	0x59
WAKE_IN6	0x61	0x62	0x63	0x64	0x65	0x66	0x67	0x68	0x69
WAKE_IN7	0x71	0x72	0x73	0x74	0x75	0x76	0x77	0x78	0x79

The codes are loaded into the FIFO buffer in the order in which they occurred. *Table 2* shows an example sequence of

events, and *Figure 2* shows the resulting sequence of event codes loaded into the FIFO buffer.

查询"LM8333FLQ8Y"供应商

TABLE 2. Example Sequence of Events

Event Number	Event Code	Event on Input	Matrix Node	Description
1	0xF1	Wake_INP7	K_OUT0	Key is pressed
2	0xB6	Wake_INP3	K_OUT5	Key is pressed
3	0x71	Wake_INP7	K_OUT0	Key is released
4	0x36	Wake_INP3	K_OUT5	Key is released
5	0xB4	Wake_INP3	K_OUT3	Key is pressed
6	0x34	Wake_INP3	K_OUT3	Key is released33
7	0x91	Wake_INP1	K_OUT0	Key is pressed
8	0x00	NA	NA	Indicates end of stored events

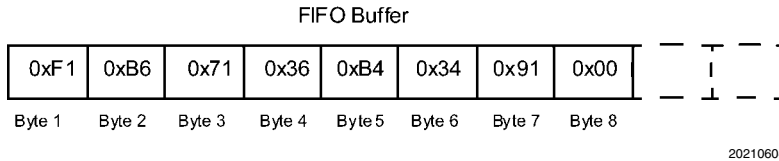

FIGURE 2. Example Event Codes Loaded in FIFO Buffer

**9.2 I/O EXPANSION**

In addition to keypad scanning, the LM8333 supports various I/O expansion options.

controlled by the PWM\_CTL command. Before activating the PWM output, the  $T_{LO}$  and  $T_{HI}$  times must be initialized. Figure 4 shows the command formats.

**9.2.1 PWM Output with Programmable Duty Cycle**

The PWM pin may be used either as a pulse-width modulated output driven by a 16-bit timer or as a general-purpose output pin. In the PWM mode, the low time ( $T_{LO}$ ) and high time ( $T_{HI}$ ) are programmable between  $1 \times t_C$  and  $65K \times t_C$  cycles in which  $t_C$  is the cycle time (nominally 1 microsecond), as shown in Figure 3. The period  $T_{PD}$  is the sum of  $T_{HI}$  and  $T_{LO}$ . The PWM\_LO command writes  $T_{LO}$ , and the PWM\_HI command writes  $T_{HI}$ . Operational modes of the PWM pin are

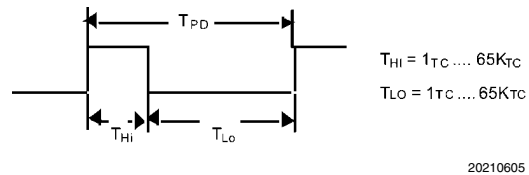

FIGURE 3. Programmable PWM

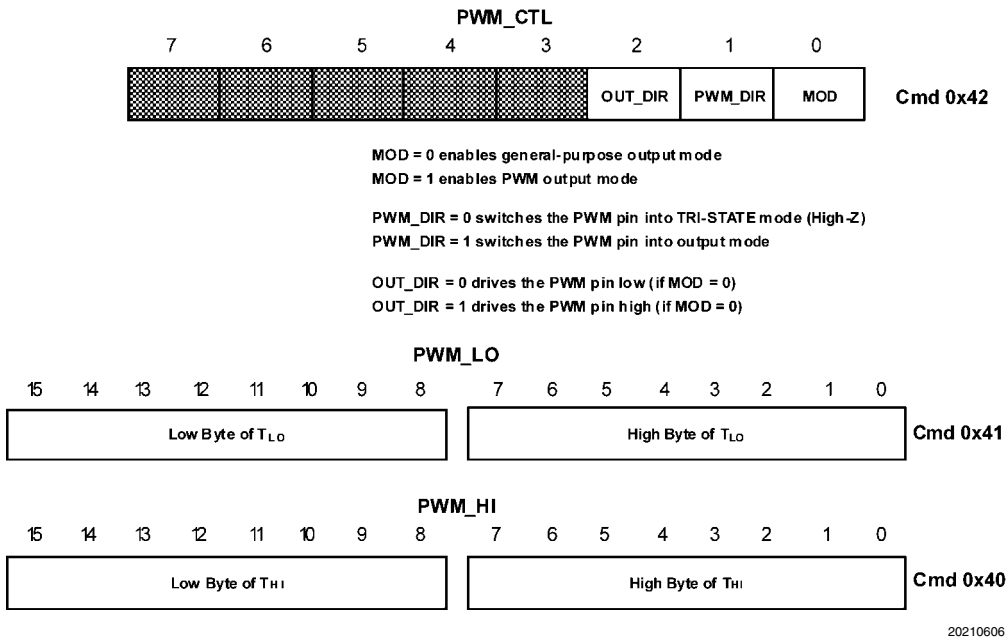

FIGURE 4. PWM Control Commands for Arbitrary Duty Cycle

TABLE 3. Summary of PWM Control Bits

OUT_DIR Bit	PWM_DIR Bit	MOD BIT	Description
0	1	0	Drive output low
1	1	0	Drive output high
0	0	0	TRI-STATE® mode
X	X	1	PWM timer output

### 9.2.2 General-Purpose I/O (GPIO)

Figure 5 shows the commands to write, read and control the general-purpose I/O port pins, GEN\_IO\_0, GEN\_IO\_1, GEN\_IO\_2, and GEN\_IO\_3.

All general-purpose I/O pins can be programmed as inputs or outputs as shown in Table 4. The GEN\_IO\_0 and GEN\_IO\_1 pins provide an additional capability for programmable wake-up.

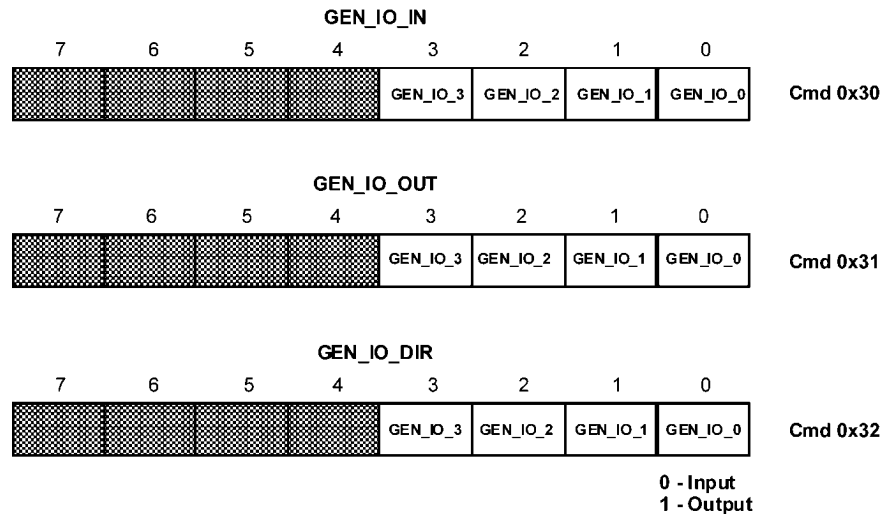

20210607

FIGURE 5. General-Purpose I/O Control Commands

Table 4 shows the pin configuration for all four combinations of control bit settings (data output and direction) for the general-purpose I/O pins. GEN\_IO\_3 cannot be put into the high

impedance (Hi-Z) input mode. When programmed as an input, it can only be configured as an input with a weak pullup.

TABLE 4. General Purpose I/O Pin Configuration

GEN_IO_DIR Bit	GEN_IO_OUT Bit	Direction	State
0	0	Input	Hi-Z
0	1	Input	Weak Pullup
1	0	Output	Drive Low
1	1	Output	Drive High

### 9.2.3 External Interrupts

When the GEN\_IO\_0 or GEN\_IO\_1 pins are configured as inputs, a SET\_EXT\_INT command (0xD1) can be used to enable receiving external interrupts on either or both of these pins. Setting the EX\_0 or EX\_1 bits in the data byte of the SET\_EXT\_INT command (as shown in Figure 6) enables the corresponding pin as an external interrupt input. When enabled as an interrupt input, any rising or falling edge causes the  $\overline{IRQ}$  output to be asserted. If the LM8333 was in Halt mode, it also wakes up into Active mode.

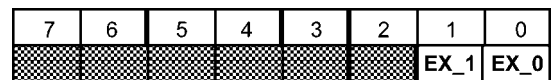

20210608

FIGURE 6. SET\_EXT\_INT Command Data Byte

When both GEN\_IO\_0 and GEN\_IO\_1 are configured as interrupt inputs, bits 1 and 2 of the interrupt code indicate which input asserted the interrupt. However, if only one of GEN\_IO\_0 or GEN\_IO\_1 is configured as an interrupt input, both bits 1 and 2 of the interrupt code will be set when an interrupt occurs.



TABLE 5. Interface Commands for Controlling the LM8333  
 查询"LM8333FLQ8Y"供应商

Function	Cmd	Dir	Data Bits	Data	Description
FIFO_READ	0x20	R	128	Event Codes from FIFO	Read an event from the FIFO. Maximum 14 event codes stored in the FIFO. MSB = 1: key pressed. MSB = 0: key released.
RPT_FIFO_READ	0x21	R	128	Event Codes from FIFO	Repeats a FIFO read without advancing the FIFO pointer, for example to retry a read after an error. Maximum 14 event codes stored in the FIFO. MSB = 1: key pressed. MSB = 0: key released.
DEBOUNCE	0x22	W	8	nnnn nnnn	Default is 10 ms. Valid range 1–255. Time ~ n × 3 ms
GEN_IO_IN	0x30	R	8	0000 nnnn	Read port data.
GEN_IO_OUT	0x31	W	8	0000 nnnn	Specify port mode. (Drive 0 or 1 when the port is configured as an output; select Hi-Z or pullup when the port is configured as an input.)
GEN_IO_DIR	0x32	W	8	0000 nnnn	Select port direction (input or output).
PWM_HI	0x40	W	16	(n+1) × t <sub>C</sub>	Sets the low pulse time of the PWM signal.
PWM_LO	0x41	W	16	(n+1) × t <sub>C</sub>	Sets the high pulse time of the PWM signal.
PWM_CTL	0x42	W	8	0000 0nnn	Activate, reactivate, or stop PWM.
READ_INT	0xD0	R	8	0000 nnnn	Reads the interrupt code, acknowledges the interrupt, deasserts the IRQ output, and clears the code.
SET_EXT_INT	0xD1	W	8	0000 00nn	Enables/disables external interrupts on GEN_IO_0 and GEN_IO_1.
READ_STAT	0xE0	R	8	000n nnnn	Status Information.
SCAN_REQ	0xE3	W	8		Requests rescanning the keypad (for example, after an error was reported).
ACTIVE	0xE4	W	8	nnnn nnnn	Specifies the time after the last event during which the LM8333 stays active before entering Halt mode. The active time must be greater than the debounce time. Default is 500 msec Valid range for n is 1–255 Time ~ n × 3 msec.
READ_ERROR	0xF0	R	8	0nnn nnnn	Reads and clears the error code.

### 9.3 HOST COMMAND EXECUTION

#### 9.3.1 Command Structure

All communication with the LM8333 over the ACCESS.bus interface is initiated by the host, usually in response to an in-

terrupt request ( $\overline{\text{IRQ}}$  low) asserted by the LM8333. *Figure 7* shows a sequence of Start conditions, slave addresses, READ\_INT command (0xD0), acknowledge cycles, data bytes, and Stop condition for reading the interrupt code.

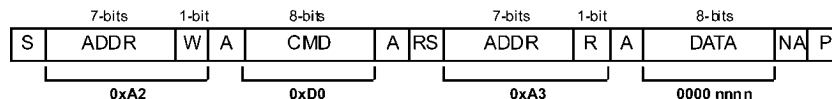

ADDR = 7-Bit Slave Address  
 S = Start Condition  
 P = Stop Condition  
 A = Acknowledgement  
 RS = Repeated Start Condition  
 NA = Negative Acknowledgement  
 CMD = Command  
 W = Write Direction Bit (0)  
 R = Read Direction Bit (1)

20210609

FIGURE 7. Typical Command Sequence from Host

Every transfer is preceded by a Start condition (S) or a Repeated Start condition (RS). The latter occurs when a command follows immediately upon another command without an intervening Stop condition (P). A Stop condition indicates the end of transmission. Every byte is acknowledged (A) by the receiver.

The first byte in a write from the host to the LM8333 is 0xA2, and the first byte in a read is 0xA3. This byte is composed of a 7-bit slave address in bits 7:1 and a direction bit in bit 0. The direction bit is 0 on writes from the host to the slave and 1 on reads from the slave to the host.

The second byte sends the command. The commands are listed in *Table 5*. In the example, the READ\_INT command (0xD0) reads the interrupt code.

The slave address is repeated in the third byte, with the direction bit set to 1. The Start (or Repeated Start) condition must be repeated whenever the slave address or the direction bit is changed. In this case, the direction bit is changed.

The data is sent from the slave to the host in the fourth byte. When the master is the receiver, it sends a negative acknowledgement (NA) to indicate the end of the data.

#### 9.4 HOST WRITE COMMANDS

Some host commands include one or more data bytes written to the LM8333. *Figure 8* shows a SET\_EXT\_INT command, which consists of an address byte, a command byte, and one data byte.

The first byte is composed of a 7-bit slave address in bits 7:1 and a direction bit in bit 0. The state of the direction bit is 0 on writes from the host to the slave and 1 on reads from the slave to the host.

The second byte sends the command. The commands are listed in *Figure 9*. The SET\_EXT\_INT command is 0xD1.

The third byte send the data, in this case configuring GEN\_IO\_0 as an external interrupt input.

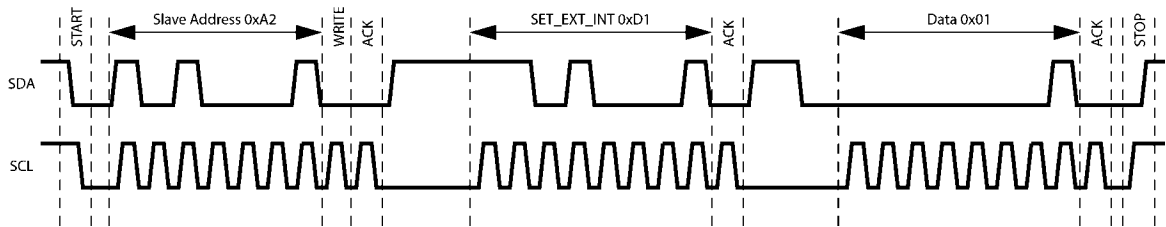

20210610

FIGURE 8. Host Write Command

#### 9.5 HOST READ COMMANDS

Some host commands include one or more data bytes read from the LM8333. *Figure 9* shows a READ\_INT command which consists of an address byte, a command byte, a second address byte, and a data byte.

The first address byte is sent with the direction bit driven low to indicate a write transaction of the command to the LM8333. The second address byte is sent with the direction bit undriven

(pulled high) to indicate a read transaction of the data from the LM8333.

The Start (or Repeated Start) condition must be repeated whenever the slave address or the direction bit is changed. In this case, the direction bit is changed.

The data is sent from the slave to the host in the fourth byte. This byte ends with a negative acknowledgement (NACK) to indicate the end of the data.

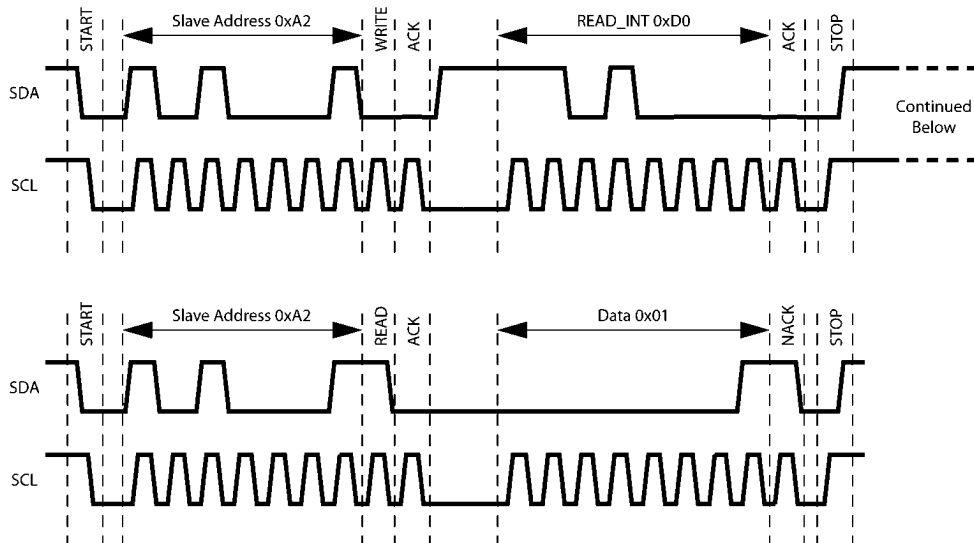

20210611

FIGURE 9. Host Read Command

## 9.6 WAKE-UP FROM HALT MODE

Any bus transaction initiated by the host may encounter the LM8333 device in Halt mode or busy with processing data, such as controlling the FIFO buffer or executing interrupt service routines.

Figure 10 shows the case in which the host sends a command while the LM8333 is in Halt mode (CPU clock is stopped). Any activity on the ACCESS.bus wakes up the LM8333, but it cannot acknowledge the first bus cycle immediately after wake-up.

The host drives a Start condition followed by seven address bits and a R/W bit. The host then releases SDA for one clock period, so that it can be driven by the LM8333.

If the LM8333 does not drive SDA low during the high phase of the clock period immediately after the R/W bit, the bus cycle

terminates without being acknowledged (shown as NACK in Figure 10). The host then aborts the transaction by sending a Stop condition. After aborting the bus cycle, the host may then retry the bus cycle. On the second attempt, the LM8333 will be able to acknowledge the slave address, because it will be in Active mode.

Alternatively, the I<sup>2</sup>C specification allows sending a START byte (0000001), which will not be acknowledged by any device. This byte can be used to wake up the LM8333 from Halt mode.

The LM8333 may also stall the bus transaction by pulling the SCL low, which is a valid behavior defined by the I<sup>2</sup>C specification.

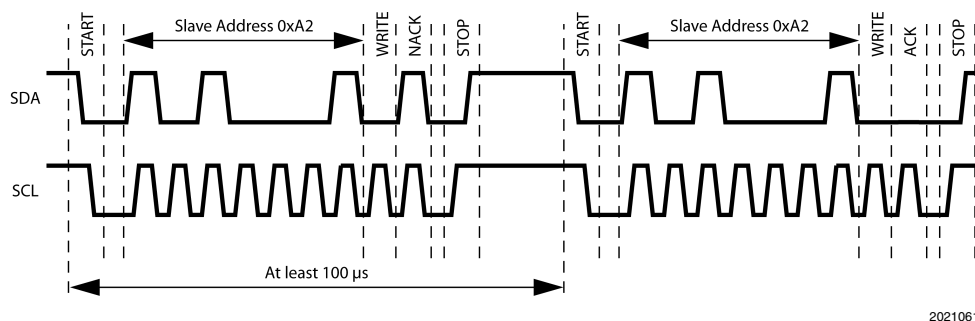

FIGURE 10. LM8333 Responds with NACK, Host Retries Command

## 10.0 Interrupts

### 10.1 INTERRUPT CODE

The interrupt code is read and acknowledged with the READ\_INT command (0xD0). This command clears the code and deasserts the IRQ output. Table 6 shows the format of the interrupt code.

Note that when only one of the interrupt-capable pins GEN\_IO\_0 or GEN\_IO\_1 is configured as an interrupt input, bits 1 and 2 are both set when an interrupt occurs. When both GEN\_IO\_0 and GEN\_IO\_1 pins are configured as interrupt inputs, only one bit corresponding to the interrupt source is set when an interrupt occurs.

TABLE 6. Interrupt Code

7	6	5	4	3	2	1	0
0	0	0	0	ERROR	EX_1	EX_0	KEYPAD

Bit	Description
ERROR	An error condition occurred.
EX_1	A rising or falling edge was detected on GEN_IO_1.
EX_0	A rising or falling edge was detected on GEN_IO_0.
KEYPAD	A key-press or key-release event occurred.

### 10.2 ERROR CODE

If the LM8333 reports an error, the READ\_ERROR command (0xF0) is used to read and clear the error code. Table 7 shows the format of the error code.

TABLE 7. Error Code

7	6	5	4	3	2	1	0
0	FIFOVR	0	NOINT	0	KEYOVR	CMDUNK	CMDOVR

Bit	Description
FIFOERR	Key event occurred while the FIFO was full.
NOINT	Interrupt deasserted before it could be serviced.
KEYOVR	More than two keys were pressed simultaneously.
CMDUNK	Not a valid command.
CMDOVR	Command received before it could be accepted, e.g. after wake-up.

### 10.3 STATUS CODES

The host can use the READ\_STAT command (0xE0) to read the status code, for example to synchronize after an error.

TABLE 8. Status Codes

Status	Code	Description
Reset	0000 0000	Default after reset.
Wake Up Interrupt	0000 0010	Wake-up caused by external interrupt.
Ack	0000 0110	Last host command was successful.
NoAck	0001 0101	Last host command was not successful.

### 10.4 INTERRUPT PROCESSING

Unexpected states encountered during run-time, for example overrun of the FIFO buffer, are reported as errors. When the host receives an interrupt from the LM8333, it uses a READ\_INT command to read the interrupt code. If the code has a set ERROR bit, the host then uses a READ\_ERROR command to read the error code, as shown in *Figure 11*.

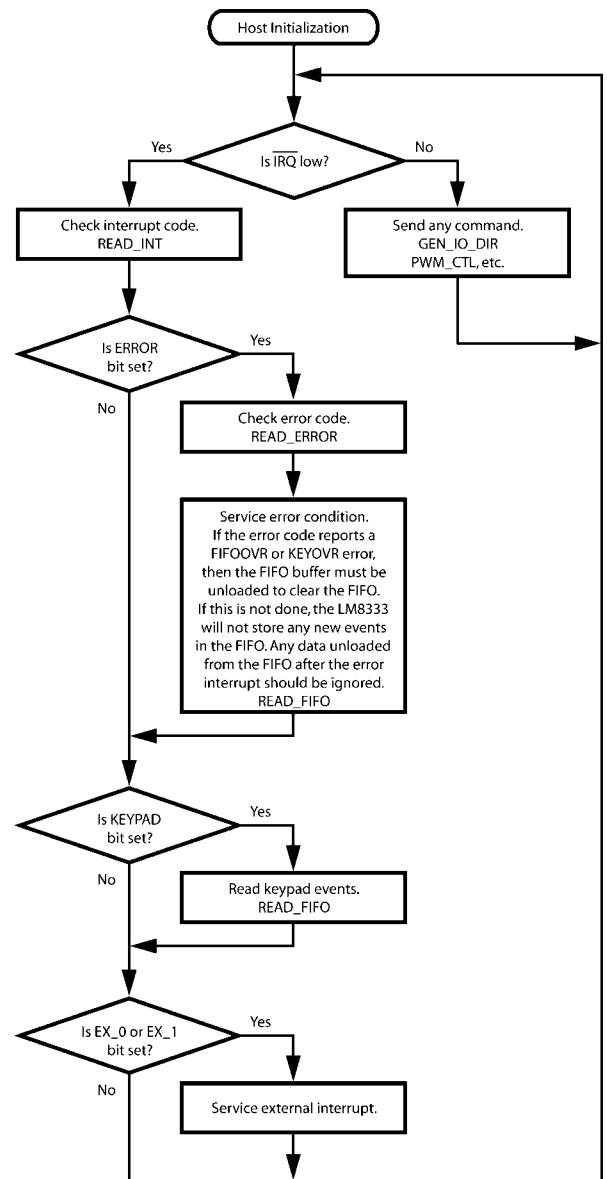

20210613

FIGURE 11. Interrupt Processing

## 10.5 COMMAND EXECUTION SUMMARY

- With the LM8333 status and error codes, the LM8333 provides the features needed to support a reliable key-scan functionality.
- Up to 14 key-scan events can be stored in an internal FIFO buffer. The end of buffer is indicated with the 00 (empty character) code.
- The host can repeatedly read the FIFO without modifying the FIFO pointer using the RPT\_FIFO\_READ command (0x21), for example if an error is encountered during a read.
- The LM8333 asserts the  $\overline{\text{IRQ}}$  output low when a new character is pressed after the last interrupt acknowledge from the host. The  $\overline{\text{IRQ}}$  output will be deasserted after the host has acknowledged the interrupt by reading the interrupt code using the READ\_INT command (0xD0).
- The host can synchronize with the LM8333 by reading the status code with the READ\_STAT command (0xE0). The status code verifies whether the last command was successfully completed.
- Two GPIO pins on the LM8333 may be configured as external interrupt inputs. A rising or falling edge on an enabled interrupt input triggers wake-up from Halt mode and asserts an interrupt to the host by pulling the  $\overline{\text{IRQ}}$  output low.
- The host can change the debounce time from the default time of 10 ms. This can be used for reliable scanning of keyboards with noisy contacts. The debounce time can be set to about 1 second in steps of 4 milliseconds. The debounce time is set with the DEBOUNCE command (0x22).
- The host can change the active time permitted before entering Halt mode from the default period of 500 ms. The active time is the time during which the keypad is scanned after the last key is released, before entering Halt mode. The active time must be longer than the debounce time.
- The host can program the direction and output state of four general-purpose I/O pins. The host can also read the states on these pins.
- The host can program a 16-bit timer for generating a PWM output. If the PWM function is not used, the PWM pin can be used as a general-purpose output.

## 11.0 Absolute Maximum Ratings (Note 1)

查询"LM8333FLQ8Y"供应商

If Military/Aerospace specified devices are required, please contact the National Semiconductor Sales Office/ Distributors for availability and specifications.

Supply Voltage ( $V_{CC}$ )	3.5V
Voltage at Any Pin	-0.3V to $V_{CC} + 0.3V$
Maximum Input Current Without Latchup	$\pm 100$ mA

ESD Protection Level	
Human Body Model	2 kV
Machine Model	200V
Total Current into VCC Pin (Source)	80 mA
Total Current out of GND Pin (Sink)	60 mA
Storage Temperature Range	$-65^{\circ}\text{C}$ to $+140^{\circ}\text{C}$

## 12.0 DC Electrical Characteristics

(Temperature:  $-40^{\circ}\text{C} \leq T_A \leq +85^{\circ}\text{C}$ )

Data sheet specification limits are guaranteed by design, test, or statistical analysis.

Symbol	Parameter	Conditions	Min (Note 2)	Typ	Max (Note 2)	Units
$V_{CC}$	Operating Voltage		2.25		2.9	V
	Power Supply Rise Time from 0.0V (On Chip Power-On Reset Selected)		20 $\mu\text{s}$		10 ms	
$I_{DD}$	Supply Current (Note 3)	RC Clock = 10 MHz, $V_{CC} = 2.75\text{V}$ , $T_C = 1 \mu\text{s}$ (Note 4)			6	mA
$I_{HALT}$	Standby Mode Current (Note 5)	$V_{CC} = 2.75\text{V}$ , $T_C = 0 \mu\text{s}$ , (Note 4), $T_A = 25^{\circ}\text{C}$		<2	15	$\mu\text{A}$
$V_{IL}$	Logical 0 Input Voltage				$0.25 V_{CC}$	V
$V_{IH}$	Logical 1 Input Voltage		$0.8 V_{CC}$			V
	Hi-Z Input Leakage (TRI-STATE Output)	$V_{CC} = 2.75\text{V}$	-0.1		0.1	$\mu\text{A}$
	Input PullupCurrent	$V_{CC} = 2.75\text{V}$ , $V_{IN} = 0\text{V}$	-15		-120	$\mu\text{A}$
	Port Input Hysteresis (Note 6)		0.1			V
	Output Current Source (Weak Pull-Up)	$V_{CC} = 2.25\text{V}$ , $V_{OH} = 1.7\text{V}$	-10		-80	$\mu\text{A}$
	Output Current Source (Push-Pull Mode)	$V_{CC} = 2.25\text{V}$ , $V_{OH} = 1.7\text{V}$	-10			mA
	Output Current Sink (Push-Pull Mode)	$V_{CC} = 2.25\text{V}$ , $V_{OL} = 0.4\text{V}$	10			mA
	Allowable Sink and Source Current per Pin				16	mA
$C_{PAD}$	Input Capacitance				8.5	pF

**Note 1:** Absolute Maximum Ratings indicate limits beyond which damage to the device may occur. Operating Ratings indicate conditions for which the device is intended to be functional, but specific performance is not guaranteed. For guaranteed specifications and test conditions, see the Electrical Characteristics tables.

**Note 2:** Data sheet minimum and maximum limits are guaranteed by design, test, or statistical analysis.

**Note 3:** Supply current is measured with inputs connected to  $V_{CC}$  and outputs driven low but not connected to a load.

**Note 4:**  $T_C$  = instruction cycle time (min. 0.7  $\mu\text{s}$ ).

**Note 5:** In Halt mode, the internal clock is switched off. Supply current in Halt mode is measured with inputs connected to  $V_{CC}$  and outputs driven low but not connected to a load.

**Note 6:** Guaranteed by design, not tested.

## 13.0 AC Electrical Characteristics

(Temperature:  $-40^{\circ}\text{C} \leq T_A \leq +85^{\circ}\text{C}$ )  
[查询"LM8333FLO8Y"供应商](#)

Data sheet specification limits are guaranteed by design, test, or statistical analysis.

Symbol	Parameter	Conditions	Min (Note 7)	Typ	Max (Note 7)	Units
	Internal Oscillator	External R from CLK_IN to Gnd (R = 68 kohm) $2.25\text{V} \leq V_{CC} \leq 2.75\text{V}$		0.75		$\mu\text{s}$
	System Oscillator (mclk)	External R from CLK_IN to Gnd (R = 68 kohm) $2.25\text{V} \leq V_{CC} \leq 2.75\text{V}$		75		ns
	System Oscillator and Internal Frequency Variation	$2.25\text{V} \leq V_{CC} \leq 2.75\text{V}$			$\pm 30$	%
	Input Pulse Width Low		0.7			$\mu\text{s}$
	Input Pulse Width High		0.7			$\mu\text{s}$
<b>ACCESS.bus Input Timing (Note 8)</b>						
$t_{\text{BUFi}}$	Bus free time between Stop and Start Condition			$t_{\text{SCLhigho}}$		
$t_{\text{CSTOHsi}}$	SCL setup time	Before Stop Condition	8			mclk
$t_{\text{CSTRHhi}}$	SCL hold time	After Start Condition	8			mclk
$t_{\text{DHCsi}}$	Data High setup time	Before SCL Rising Edge (RE)	2			mclk
$t_{\text{DLCsi}}$	Data Low setup time	Before SCL RE	2			mclk
$t_{\text{SCLlowi}}$	SCL low time	After SCL Falling Edge (FE)	12			mclk
$t_{\text{SCLhighi}}$	SCL high time	After SCL RE	12			mclk
$t_{\text{SDAhi}}$	SDA hold time	After SCL FE	0			ns
$t_{\text{SDAsi}}$	SDA setup time	Before SCL RE	2			mclk
<b>ACCESS.bus Output Timing (Note 8)</b>						
$t_{\text{BUFo}}$	Bus free time between Stop and Start Condition			$t_{\text{SCLhigho}}$		
$t_{\text{CSTOso}}$	SCL setup time	Before Stop Condition		$t_{\text{SCLhigho}}$		
$t_{\text{CSTRho}}$	SCL hold time	After Start Condition		$t_{\text{SCLhigho}}$		
$t_{\text{CSTRso}}$	SCL setup time	Before Start Condition		$t_{\text{SCLhigho}}$		
$t_{\text{DHCso}}$	Data High setup time	Before SCL RE		$t_{\text{SCLhigho}}$		
$t_{\text{DLCso}}$	Data Low setup time	Before SCL RE		$t_{\text{SCLhigho}}$		
$t_{\text{SCLlowo}}$	SCL low time	After SCL FE	16			mclk
$t_{\text{SCLhigho}}$	SCL high time	After SCL RE	16			mclk
$t_{\text{SDAho}}$	SDA hold time	After SCL FE	7			mclk
$t_{\text{SDAv0}}$	SDA valid time	Before SCL FE	7			mclk

**Note 7:** Data sheet minimum and maximum limits are guaranteed by design, test, or statistical analysis.

**Note 8:** The ACCESS.bus interface of the LM8333 device implements and meets the timing necessary for interface to the I<sup>2</sup>C bus and SMBus protocol at logic levels. The bus drivers are designed with open-drain output as required for bidirectional operation. The LM8333 device will not meet the AC timing and current/voltage requirements of the full bus specification.

[查询"LM8333FLQ8Y"供应商](#)

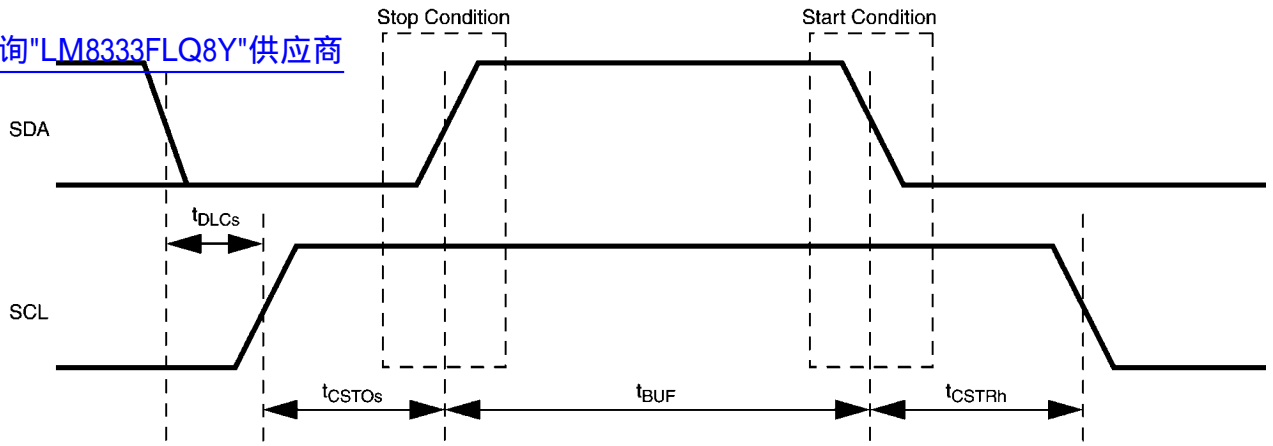

Note: In the timing tables the parameter name is appended with an "o" for output signal timing and "i" for input signal timing.

20210614

**FIGURE 12. ACCESS.bus Start and Stop Condition Timing**



# 14.0 Physical Dimensions inches (millimeters) unless otherwise noted

[查询"LM8333FLQ8Y"供应商](#)

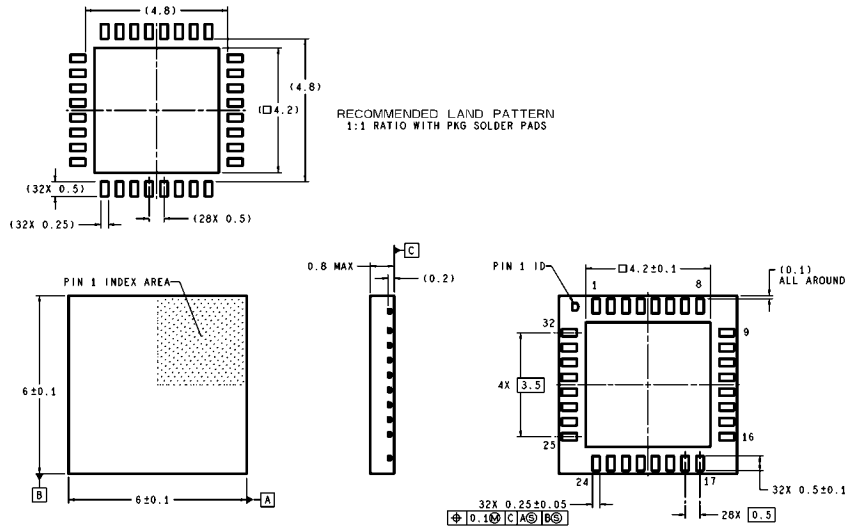

DIMENSIONS ARE IN MILLIMETERS

LQ832A (Rev A)

## Leadless Leadframe Package Order Number LM8333FLQ8X or LM8333FLQ8Y NS Package Number LQA32A

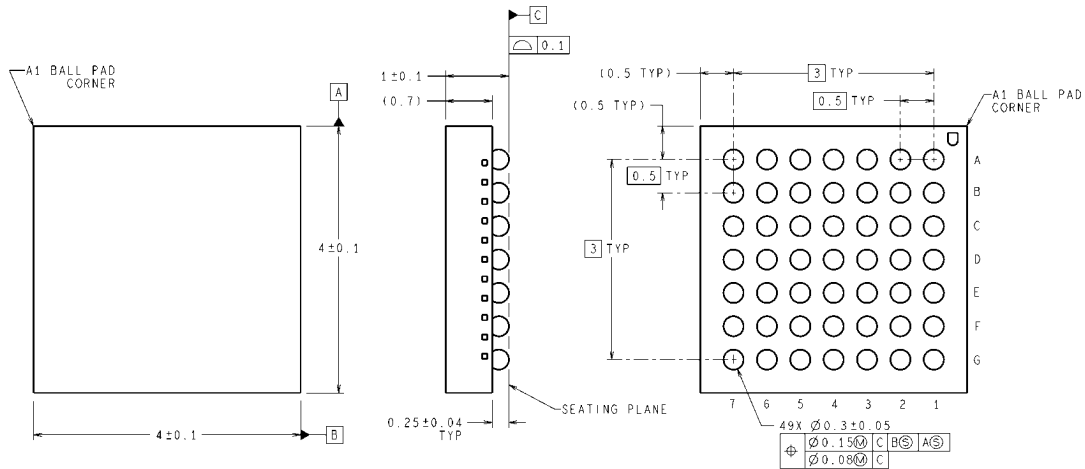

DIMENSIONS ARE IN MILLIMETERS  
DIMENSIONS IN ( ) FOR REFERENCE ONLY

GRA49A (Rev A)

## Micro Array Package Order Number LM8333GGR8 NS Package Number GRA49A

[查询"LM8333FLQ8Y"供应商](#)

## Notes

THE CONTENTS OF THIS DOCUMENT ARE PROVIDED IN CONNECTION WITH NATIONAL SEMICONDUCTOR CORPORATION ("NATIONAL") PRODUCTS. NATIONAL MAKES NO REPRESENTATIONS OR WARRANTIES WITH RESPECT TO THE ACCURACY OR COMPLETENESS OF THE CONTENTS OF THIS PUBLICATION AND RESERVES THE RIGHT TO MAKE CHANGES TO SPECIFICATIONS AND PRODUCT DESCRIPTIONS AT ANY TIME WITHOUT NOTICE. NO LICENSE, WHETHER EXPRESS, IMPLIED, ARISING BY ESTOPPEL OR OTHERWISE, TO ANY INTELLECTUAL PROPERTY RIGHTS IS GRANTED BY THIS DOCUMENT.

TESTING AND OTHER QUALITY CONTROLS ARE USED TO THE EXTENT NATIONAL DEEMS NECESSARY TO SUPPORT NATIONAL'S PRODUCT WARRANTY. EXCEPT WHERE MANDATED BY GOVERNMENT REQUIREMENTS, TESTING OF ALL PARAMETERS OF EACH PRODUCT IS NOT NECESSARILY PERFORMED. NATIONAL ASSUMES NO LIABILITY FOR APPLICATIONS ASSISTANCE OR BUYER PRODUCT DESIGN. BUYERS ARE RESPONSIBLE FOR THEIR PRODUCTS AND APPLICATIONS USING NATIONAL COMPONENTS. PRIOR TO USING OR DISTRIBUTING ANY PRODUCTS THAT INCLUDE NATIONAL COMPONENTS, BUYERS SHOULD PROVIDE ADEQUATE DESIGN, TESTING AND OPERATING SAFEGUARDS.

EXCEPT AS PROVIDED IN NATIONAL'S TERMS AND CONDITIONS OF SALE FOR SUCH PRODUCTS, NATIONAL ASSUMES NO LIABILITY WHATSOEVER, AND NATIONAL DISCLAIMS ANY EXPRESS OR IMPLIED WARRANTY RELATING TO THE SALE AND/OR USE OF NATIONAL PRODUCTS INCLUDING LIABILITY OR WARRANTIES RELATING TO FITNESS FOR A PARTICULAR PURPOSE, MERCHANTABILITY, OR INFRINGEMENT OF ANY PATENT, COPYRIGHT OR OTHER INTELLECTUAL PROPERTY RIGHT.

### LIFE SUPPORT POLICY

**NATIONAL'S PRODUCTS ARE NOT AUTHORIZED FOR USE AS CRITICAL COMPONENTS IN LIFE SUPPORT DEVICES OR SYSTEMS WITHOUT THE EXPRESS PRIOR WRITTEN APPROVAL OF THE CHIEF EXECUTIVE OFFICER AND GENERAL COUNSEL OF NATIONAL SEMICONDUCTOR CORPORATION.** As used herein:

Life support devices or systems are devices which (a) are intended for surgical implant into the body, or (b) support or sustain life and whose failure to perform when properly used in accordance with instructions for use provided in the labeling can be reasonably expected to result in a significant injury to the user. A critical component is any component in a life support device or system whose failure to perform can be reasonably expected to cause the failure of the life support device or system or to affect its safety or effectiveness.

National Semiconductor and the National Semiconductor logo are registered trademarks of National Semiconductor Corporation. All other brand or product names may be trademarks or registered trademarks of their respective holders.

Copyright© 2007 National Semiconductor Corporation

For the most current product information visit us at [www.national.com](http://www.national.com)



**National Semiconductor  
Americas Customer  
Support Center**  
Email:  
[new.feedback@nsc.com](mailto:new.feedback@nsc.com)  
Tel: 1-800-272-9959

**National Semiconductor Europe  
Customer Support Center**  
Fax: +49 (0) 180-530-85-86  
Email: [europe.support@nsc.com](mailto:europe.support@nsc.com)  
Deutsch Tel: +49 (0) 69 9508 6208  
English Tel: +49 (0) 870 24 0 2171  
Français Tel: +33 (0) 1 41 91 8790

**National Semiconductor Asia  
Pacific Customer Support Center**  
Email: [ap.support@nsc.com](mailto:ap.support@nsc.com)

**National Semiconductor Japan  
Customer Support Center**  
Fax: 81-3-5639-7507  
Email: [jpn.feedback@nsc.com](mailto:jpn.feedback@nsc.com)  
Tel: 81-3-5639-7560