

Sync Separator with AFC Monolithic IC LVA519

Outline

This is a sync separator IC with AFC. Stable operation even in a weak electric field is made possible with the built-in AFC circuit. A regulator also is built in, providing stable operation relative to power supply and temperature fluctuations.

Features

1. Supports AFC (horizontal sync signal)
2. AFC OFF function
3. Horizontal and vertical sync signal output pins
4. Power supply voltage 4.7V~5.3V

Package

- SIP-9A (LVA519S)
- SOP-14A (LVA519F)

Applications

1. TV
2. VCR
3. Other video equipment

Equivalent Circuit Diagram

■ SIP-9A

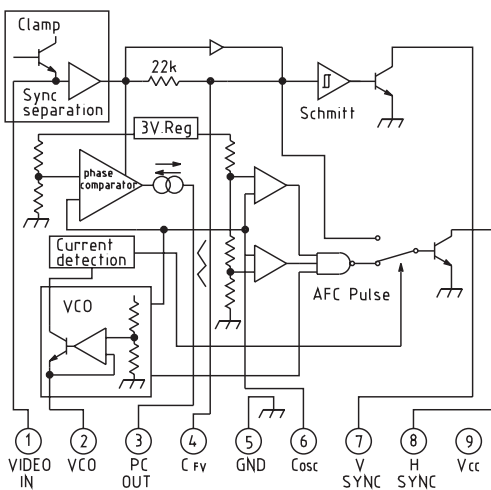

■ SOP-14A

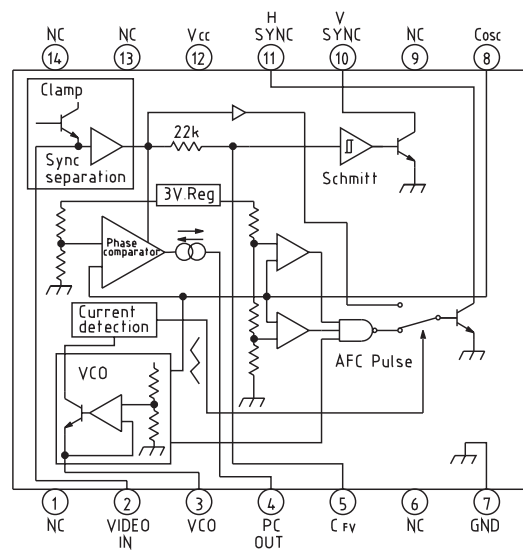

查询"LVA519"供应商
Pin Description (LVA519S)

Pin no.	Pin name	Function	Internal equivalent circuit diagram
1	VIDEO IN	Video signal input	
2	Vco	Free run frequency setting	
3	PC OUT	Phase comparison output	
4	CFU	Integrates composite signal and inputs to vertical sync playback circuit	

[查询"LVA519"供应商](#)

5	GND	GND	
6	Cosc	Free run frequency oscillation circuit	
7	V _{SYNC}	Vertical sync signal output	
8	H _{SYNC}	Horizontal sync signal output	
9	V _{CC}	Power supply	

Pin Description (LVA519F)

Pin no.	Pin name	Function	Internal equivalent circuit diagram
1		NC	
2	VIDEO IN	Video signal input	
3	V _{CO}	Free run frequency setting	

[查询"LVA519"供应商](#)

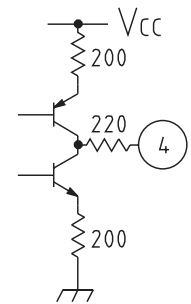
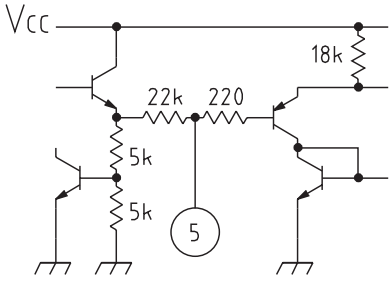
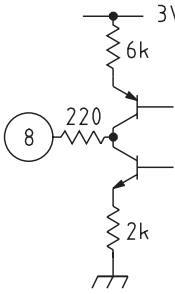
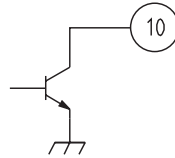
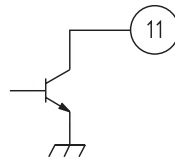
4	PC OUT	Phase comparison output	
5	CFU	Integrates composite signal and inputs to vertical sync playback circuit	
6		NC	
7	GND	GND	
8	Cosc	Free run frequency oscillation circuit	
9		NC	
10	V _{SYNC}	Vertical sync signal output	
11	H _{SYNC}	Horizontal sync signal output	
12	V _{CC}	Power supply	
13		NC	
14		NC	

查询"LVA519"供应商

Absolute Maximum Ratings (Ta=25°C)

Item	Symbol	Ratings	Units
Storage temperature	T _{STG}	-40~+125	°C
Operating temperature	T _{OPR}	-2~+75	°C
Power supply voltage	V _{CC} max.	7	V
Allowable loss	P _d	470 (SIP-9A) 350 (SOP-14A)	mW

Recommended Operating Conditions (Ta=25°C)

Item	Symbol	Min.	Typ.	Max.	Units
Recommended power supply voltage range	V _{CC}	4.7	5.0	5.3	V
Recommended input signal voltage	V _{IN}	0.8	2.0	3.2	V _{P-P}

Electrical Characteristics (Except where noted otherwise, Ta=25°C, V_{CC}=5.0V, V_{IN}=2.0V_{P-P})

Item	Symbol	Measurement conditions	Min.	Typ.	Max.	Units	
Consumption current	I _d	Refer to Measuring Circuit		7.0	10	mA	
Horizontal sync output (H)	V _{HH}	Refer to Measuring Circuit	4.9	5.0		V	
Horizontal sync output (L)	V _{HL}	Refer to Measuring Circuit		0.2	0.4	V	
Vertical sync output (H)	V _{VH}	Refer to Measuring Circuit	4.9	5.0		V	
Vertical sync output (L)	V _{VL}	Refer to Measuring Circuit		0.2	0.4	V	
Free-running frequency setting range	f _o	Refer to Measuring Circuit	14.5		17.0	kHz	
Power supply fluctuation of free-running frequency	Δf _{o1}	Refer to Measuring Circuit		300		%/V	
Free-running frequency temperature coefficient Capture range	Δf _{o2}	Refer to Measuring Circuit		400		ppm/V	
Capture range	f _c	Refer to Measuring Circuit	1.0	1.3		kHz	
Lock range	f _l	Refer to Measuring Circuit	1.9	2.5		kHz	
AFC output delay time	t _d	Refer to Measuring Circuit	0.3	0.7	1.1	μS	
AFC output pulse width	P _w	Refer to Measuring Circuit	3.5	5.0	6.5	μS	
Schmitt trigger threshold	(H)	V _{thH}	Refer to Measuring Circuit	1.9	2.1	2.3	V
	(L)	V _{thL}	Refer to Measuring Circuit	1.1	1.3	1.5	V
Sync separation level	V _{SEPA}	Refer to Measuring Circuit	80	115	170	mV	
AFC off resistance	R _{AFC}	Refer to Measuring Circuit	2.7	4.0	6.0	kΩ	

查询"LVA519"供应商

Measuring Procedures

(Except where noted otherwise, Ta=25°C, Vcc=5.0V, Vin=2.0Vp-p)

Item	Symbol	Switch state					Measuring Procedures
		S1	S2	S3	S4	S5	
Consumption current	Id	B	B	A	A	A	Connect a DC ammeter to Vcc pin.
Horizontal sync output	(H) V _{HH}	B	A	B	B	A	Input standard color bar 2V _{P-P} .
	(L) V _{HL}	B	A	B	B	A	Measure at TP5
Vertical sync output	(H) V _{VH}	B	A	B	B	A	Input standard color bar 2V _{P-P} .
	(L) V _{VL}	B	A	B	B	A	Measure at TP4.
Free-running frequency setting range	f _o	A	B	B	B	A	Adjust VR1 and measure frequency at TP5.
Power supply fluctuation of free-running frequency	Δf _{o1}	A	B	B	B	A	With f _o at 15.73kHz, vary Vcc between 4.0V~6.0V and measure at TP5.
Free-running frequency temperature coefficient	Δf _{o2}	A	B	B	B	A	With f _o at 15.73kHz, vary temperature between -20°C and 80°C and measure at TP5.
Capture range	f _c	B/A	A	B	B	A	Input standard color bar 2V _{P-P} and measure at TP1 and TP5. *1
Lock range	f _L	B/A	A	B	B	A	Input standard color bar 2V _{P-P} and measure at TP1 and TP5. *1
AFC output delay time	t _d	A/B	A	B	B	A	Input standard color bar 2V _{P-P} and measure at TP2 and TP5. *2
AFC output pulse width	P _w	A/B	A	B	B	A	Input standard color bar 2V _{P-P} and measure at TP5. *2
Schmitt trigger threshold	(H) V _{tHH}	B	A	B	B	A	Measure at TP3 and TP4. *3
	(L) V _{tHL}						

Measuring Procedures

(Except where noted otherwise, Ta=25°C, Vcc=5.0V, Vin=2.0Vp-p)

Item	Symbol	Switch state					Measuring Procedures
		S1	S2	S3	S4	S5	
Sync separation level	V _{SEPA}	B	A	B	B	A	Raise horizontal sync signal level of input standard color bar 2V _{P-P} and measure the level when a signal is output at TP5.
AFC switching resistance	R _{AFC}	B	A	B	B	B	With F _o at 15.73kHz, vary I _{afc} , and determine according to I _{afc} value when TP5 output signal switches to a composite signal, and TP6 voltage V6. R _{AFC} =V6/I _{A1}

Notes:

*1 Capture range (f_c) Vary VR1 between max→min and min→max with SW1, and for each lock make SW1 A and measure at TP5.

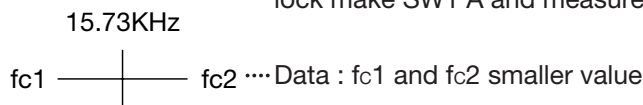

Lock range (f_L) With SW1 at B and locked, vary VR1 and when the lock is released, make SW1 A and measure at TP5.

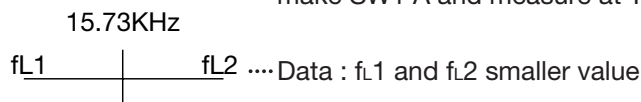

[查询"LVA519"供应商](#)

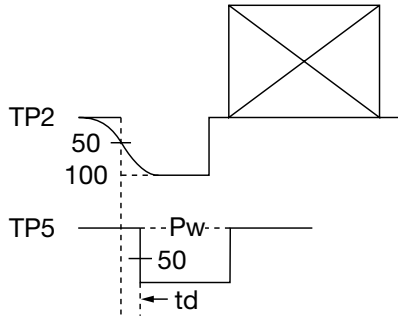

* AFC output delay time (t_d)
 Set SW1 at A and adjust TP5 output to 15.73kHz. Then set SW1 to B and measure t_d from TP2 and TP5 waveforms. (specified at 50% of sync signal amplitude)

* AFC output pulse width (P_w)
 Set SW1 at A and adjust TP5 output to 15.73kHz. Then set SW1 to B and measure P_w from TP5 waveform. (specified at 50% of sync signal amplitude)

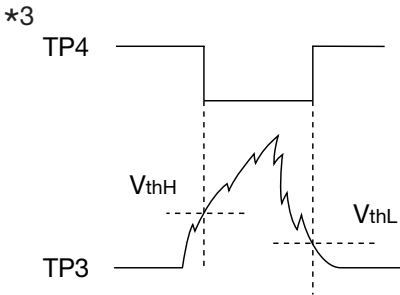

* Schmitt trigger threshold (V_{thH}) (V_{thL})
 Measure V_{thH} and V_{thL} at TP3 and TP4.

Measuring Circuit

■ SIP-9A

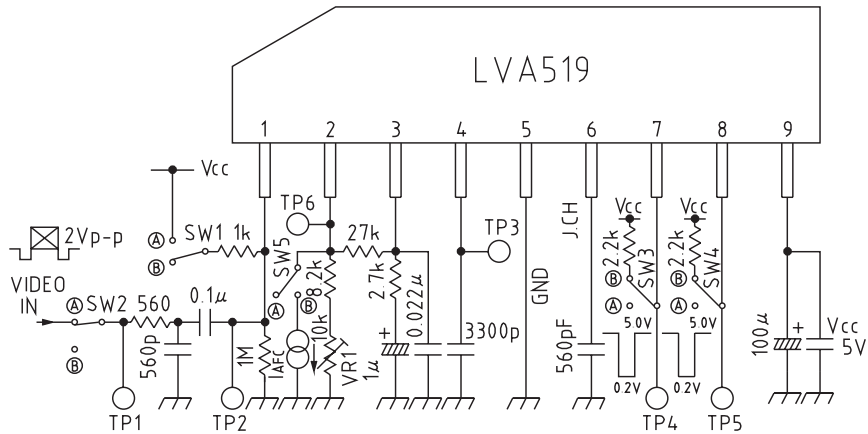

■ SOP-14A

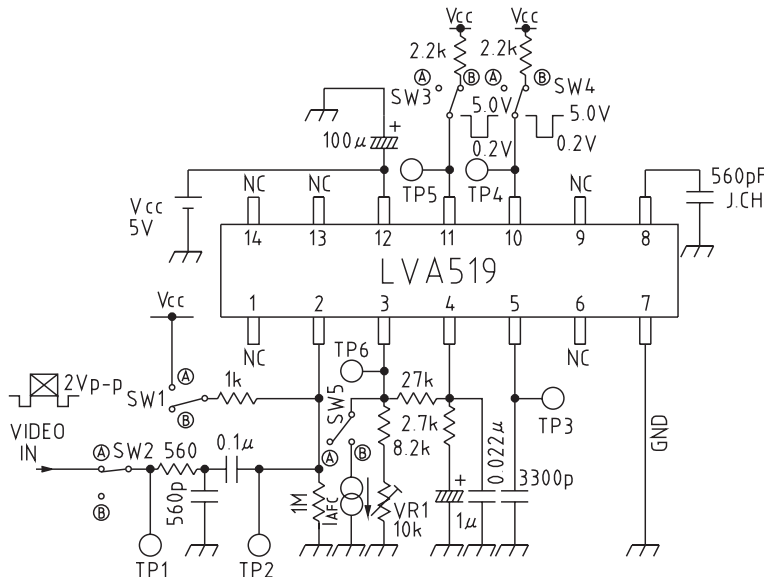

Application Circuits

SIP-9A

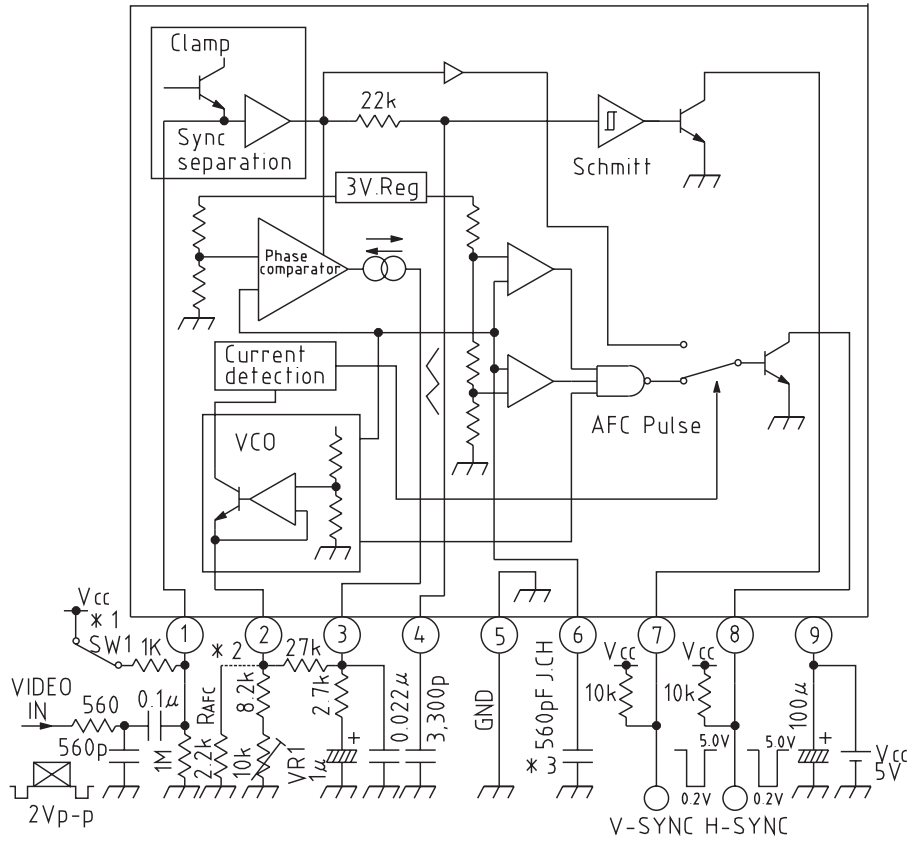

SOP-14A

