



LNBTVSx-22xx

Lightning protection for LNB power supply

Features

- 3 kV, 4 kV and 6 kV protection (8/20 μs)
- Axial & SMD package
- Unidirectional and low V_F
($V_F = 1.2\text{ V}$ at $I_F = 3\text{ A}$)
- Low clamping factor
- Fast response time

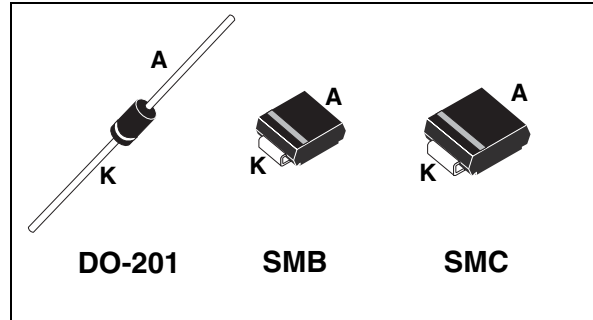

Description

The LNBTVSx-22xx is a dedicated lightning and electrical overstress surge protection for LNB voltage regulators in satellite set top box applications.

This device provides the lightning protection required to pass the IEC and FCC regulations.

Available in axial, SMB and SMC packages, this device is compatible with industry standard mounting processes.

Order Code

Part number	Marking
LNBTVS3-220	LNBTVS3-220
LNBTVS3-220U	LC
LNBTVS4-220	LNBTVS4-220
LNBTVS4-220S	LAA
LNBTVS4-221	LNBTVS4-221
LNBTVS4-221S	LAB
LNBTVS4-222S	LAC
LNBTVS6-220S	LBA
LNBTVS6-221S	LBB

Table 1. Absolute maximum ratings ($T_{amb} = 25^\circ\text{C}$)

Symbol	Parameter	Value	Unit
P_{PP}	Peak pulse power dissipation ⁽¹⁾	$T_j \text{ initial} = T_{amb}$ up to 3 kW	W
P	Peak dissipation on infinite heatsink	$T_{amb} = 75^\circ\text{C}$ 5	W
I_{FSM}	Non repetitive surge peak forward current for unidirectional types	$T_p = 10\text{ ms}$ $T_j \text{ initial} = T_{amb}$ 200	A
T_{stg}	Storage temperature range	-65 to + 175	$^\circ\text{C}$
T_j	Maximum junction temperature	150	$^\circ\text{C}$
T_L	Maximum lead temperature for soldering during 10 s at 5 mm from case	230	$^\circ\text{C}$

1. For a surge greater than the maximum values, the diode will fail in short-circuit.

1 Characteristics

Table 2. Thermal resistance

Symbol	Parameter	Package	Value	Unit
$R_{th(j-l)}$	Junction to leads	DO-201	20	° C/W
$R_{th(j-a)}$	Junction to ambient on printed circuit $L_{lead} = 10\text{ mm}$	DO-201	75	° C/W
$R_{th(j-l)}$	Junction to case	SMB	20	° C/W
$R_{th(j-a)}$	Junction to ambient on printed circuit	SMB	100	° C/W
$R_{th(j-l)}$	Junction to case	SMC	20	° C/W
$R_{th(j-a)}$	Junction to ambient on printed circuit	SMC	75	° C/W

Table 3. Electrical characteristics ($T_{amb} = 25^\circ\text{C}$)

Symbol	Parameter
V_{BR}	Breakdown voltage
I_{RM}	Leakage current @ V_{RM}
V_{RM}	Stand-off voltage
V_{CL}	Clamping voltage
I_{PP}	Peak pulse current
$R_{I/O}$	Series resistance between Input & Output
C_{line}	Input capacitance per line
I_F	Forward current
V_F	Forward voltage

Type	$I_{RM} @ V_{RM}$		$V_{BR} @ I_R$				P_{PP} 10/1000 μs	$V_{CL} @ I_{pp}$ 10/1000 μs		$V_{CL} @ I_{pp}$ 8/20 μs (1)		αT	C
	Max		Min	Typ	Max			Max		Max			
Unidirectional	μA	V	V	V	V	mA	W	V	A	V	A	$10^{-4}/^\circ\text{C}$	pF
LNBTVS3-220	1	20	22	23.1	24.2	1	1500	33.2	45	35	250	9.6	3000
LNBTVS3-220U	1	20	22	23.1	24.2	1	1500	33.2	45	35	250	9.6	3000
LNBTVS4-220	1	20	22	23.1	24.2	1	1800	33.2	55	35	331	9.6	3500
LNBTVS4-220S	1	20	22	23.1	24.2	1	1800	33.2	55	35	331	9.6	3500
LNBTVS4-221	1	20	22	23.1	24.2	1	2000	33.2	60	32	331	9.6	5500
LNBTVS4-221S	1	20	22	23.1	24.2	1	2000	33.2	60	32	331	9.6	5500
LNBTVS4-222S	1	20	22	23.1	24.2	1	3000	33.2	90	30	331	9.6	6000
LNBTVS6-220S	1	20	22	23.1	24.2	1	3000	33.2	90	35	500	9.6	6000
LNBTVS6-221S	1	20	22	23.1	24.2	1	3000	33.2	90	32	500	9.6	6000

1. IEC 61000-4-5 R = 12 Ω

Figure 1. Surge test examples at +4 kV - IEC 61000-4-5 - with series resistor of 12 Ω

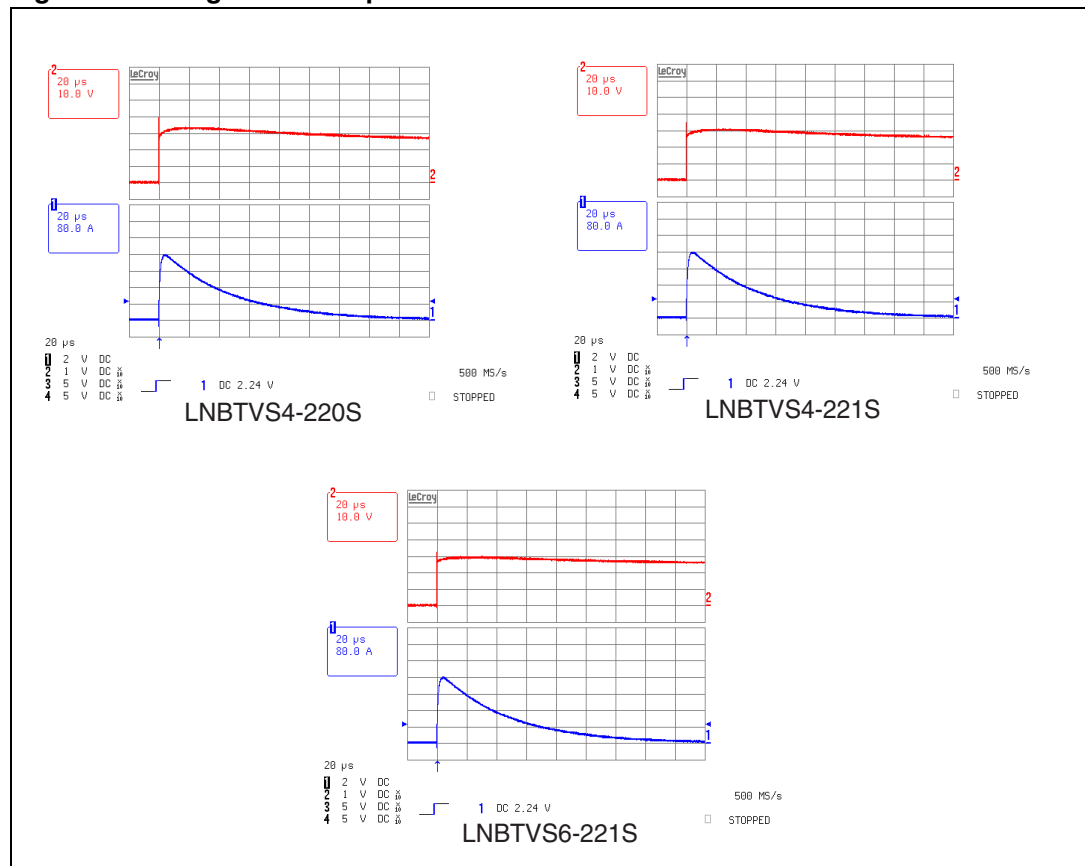

2 Application

Figure 2. Application diagram

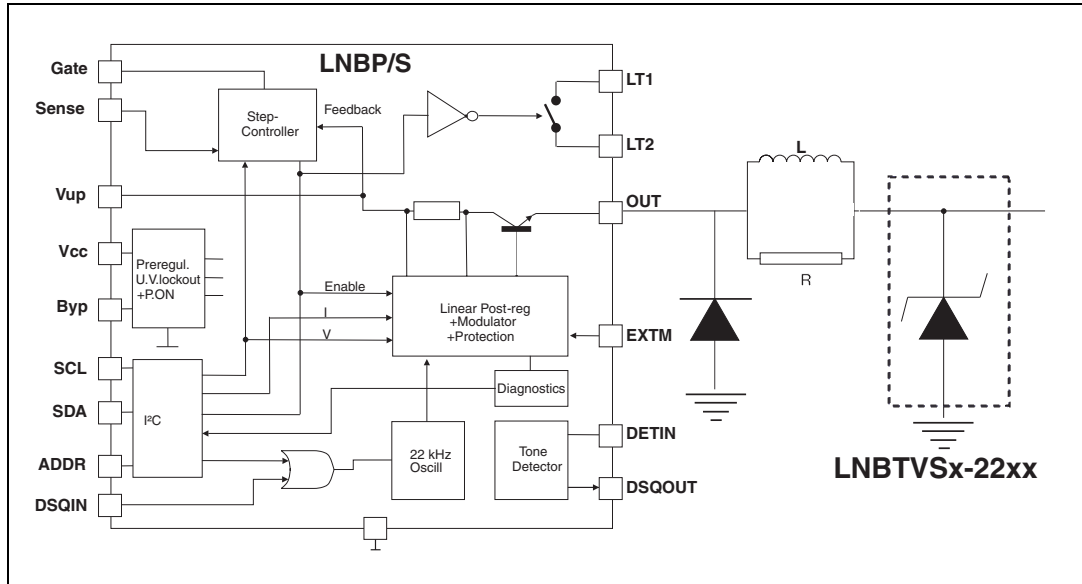
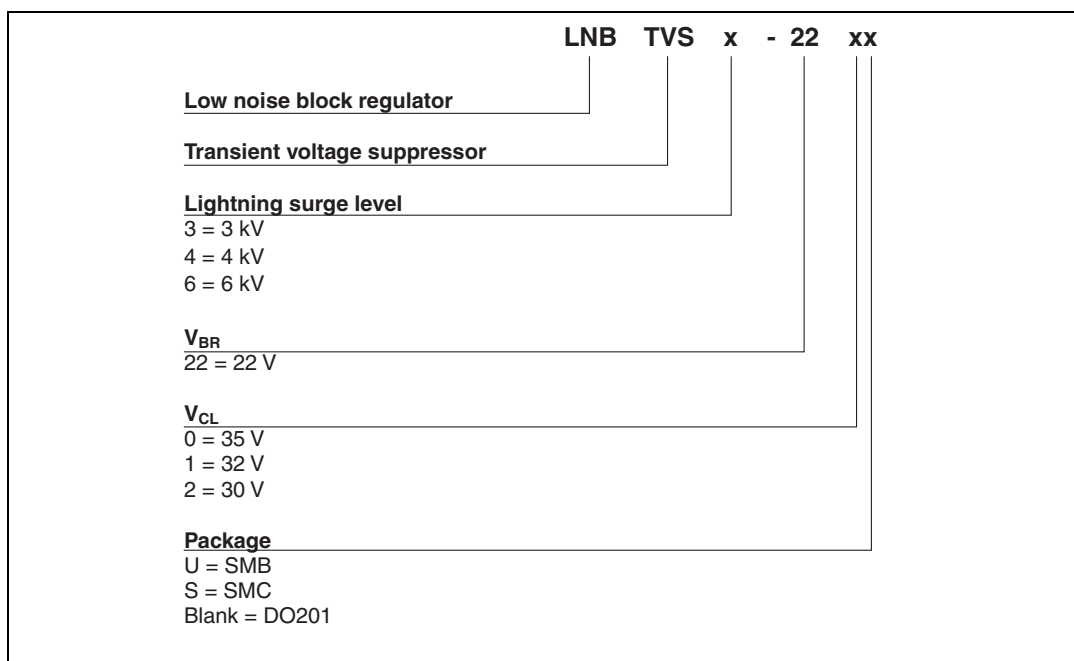

Table 4. Optimized fit to ST voltage regulators

LNB voltage regulators	Recommended lightning protections
LNBP20, LNBP11x, LNBP8/9	LNBTVS3-220/x, LNBTVS4-220/x, LNBTVS6-220S, LNBTVS6-221S
LNBS21, LNBP21	LNBTVS4-222S, LNBTVS6-221S
LNBH21, LNBH221, LNBH22, LNBEH21, LNBEH221	LNBTVS4-220/x, LNBTVS4-221/x, LNBTVS6-221S
LNBH23, LNBH24	LNBTVS4-221/x, LNBTVS4-222S, LNBTVS6-221S

3 Ordering information scheme



4 Package information

- Epoxy meets UL 94, V0

Table 5. SMC package dimensions

REF.	DIMENSIONS			
	Millimeters		Inches	
	Min.	Max.	Min.	Max.
A1	1.90	2.45	0.075	0.096
A2	0.05	0.20	0.002	0.008
b	2.90	3.2	0.114	0.126
c	0.15	0.41	0.006	0.016
E	7.75	8.15	0.305	0.321
E1	6.60	7.15	0.260	0.281
E2	4.40	4.70	0.173	0.185
D	5.55	6.25	0.218	0.246
L	0.75	1.60	0.030	0.063

Figure 3. SMC footprint (dimensions in mm)

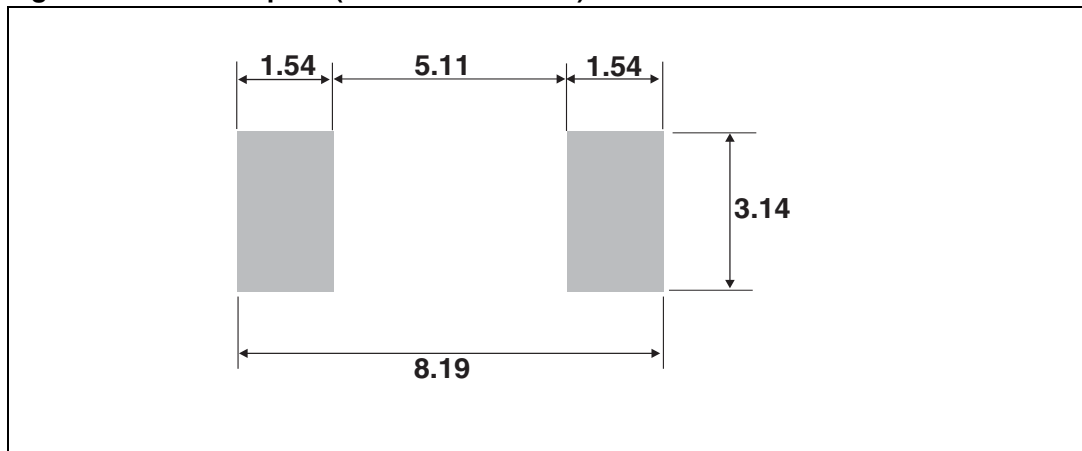

Table 6. SMB package dimensions

REF.	DIMENSIONS			
	Millimeters		Inches	
	Min.	Max.	Min.	Max.
A1	1.90	2.45	0.075	0.096
A2	0.05	0.20	0.002	0.008
b	1.95	2.20	0.077	0.087
c	0.15	0.41	0.006	0.016
E	5.10	5.60	0.201	0.220
E1	4.05	4.60	0.159	0.181
D	3.30	3.95	0.130	0.156
L	0.75	1.60	0.030	0.063

Figure 4. SMB footprint (dimensions in mm)

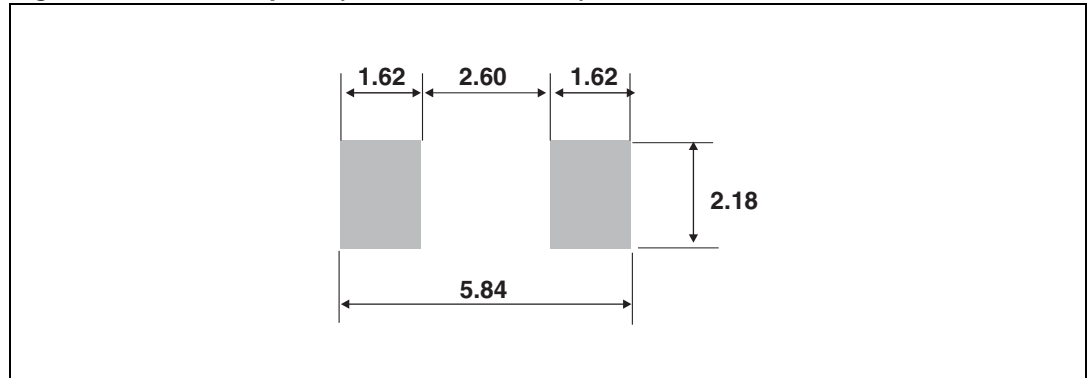

Table 7. DO-201 package dimensions

REF.	DIMENSIONS			
	Millimeters		Inches	
	Min.	Max.	Min.	Max.
A	8.5	9.5	0.335	0.374
B	25.4		1	
Ø C	4.8	5.3	0.189	0.209
Ø D	0.96	1.06	0.038	0.042

In order to meet environmental requirements, ST offers these devices in ECOPACK® packages. These packages have a lead-free second level interconnect. The category of second level interconnect is marked on the package and on the inner box label, in compliance with JEDEC Standard JESD97. The maximum ratings related to soldering conditions are also marked on the inner box label. ECOPACK is an ST trademark. ECOPACK specifications are available at: www.st.com.

5 Ordering information

Part number	Marking	Package	Weight	Base qty	Delivery mode
LNBTVS3-220	LNBTVS3-220	DO-201	0.83	600	Amopack
LNBTVS3-220U	LC	SMB	0.107	2500	Tape and reel
LNBTVS4-220	LNBTVS4-220	DO-201	0.83	600	Amopack
LNBTVS4-220S	LAA	SMC	0.245	2500	Tape and reel
LNBTVS4-221	LNBTVS4-221	DO-201	0.83	600	Amopack
LNBTVS4-221S	LAB	SMC	0.245	2500	Tape and reel
LNBTVS4-222S	LAC	SMC	0.245	2500	Tape and reel
LNBTVS6-220S	LBA	SMC	0.245	2500	Tape and reel
LNBTVS6-221S	LBB	SMC	0.245	2500	Tape and reel

6 Revision history

Date	Revision	Changes
30-Sep-2005	1	First release
10-Apr-2006	2	Reformatted to current standard. Corrected peak pulse power dissipation for LNBTVS6-220S in Table 2. Corrected footprint dimensions for SMC and SMB packages.
29-Jan-2007	3	Added surge test examples in Figure 1. Added Table 4. Optimized fit to ST voltage regulators. Added cathode bar indicators in package illustrations on page 1.

Please Read Carefully:

Information in this document is provided solely in connection with ST products. STMicroelectronics NV and its subsidiaries ("ST") reserve the right to make changes, corrections, modifications or improvements, to this document, and the products and services described herein at any time, without notice.

All ST products are sold pursuant to ST's terms and conditions of sale.

Purchasers are solely responsible for the choice, selection and use of the ST products and services described herein, and ST assumes no liability whatsoever relating to the choice, selection or use of the ST products and services described herein.

No license, express or implied, by estoppel or otherwise, to any intellectual property rights is granted under this document. If any part of this document refers to any third party products or services it shall not be deemed a license grant by ST for the use of such third party products or services, or any intellectual property contained therein or considered as a warranty covering the use in any manner whatsoever of such third party products or services or any intellectual property contained therein.

UNLESS OTHERWISE SET FORTH IN ST'S TERMS AND CONDITIONS OF SALE ST DISCLAIMS ANY EXPRESS OR IMPLIED WARRANTY WITH RESPECT TO THE USE AND/OR SALE OF ST PRODUCTS INCLUDING WITHOUT LIMITATION IMPLIED WARRANTIES OF MERCHANTABILITY, FITNESS FOR A PARTICULAR PURPOSE (AND THEIR EQUIVALENTS UNDER THE LAWS OF ANY JURISDICTION), OR INFRINGEMENT OF ANY PATENT, COPYRIGHT OR OTHER INTELLECTUAL PROPERTY RIGHT.

UNLESS EXPRESSLY APPROVED IN WRITING BY AN AUTHORIZED ST REPRESENTATIVE, ST PRODUCTS ARE NOT RECOMMENDED, AUTHORIZED OR WARRANTED FOR USE IN MILITARY, AIR CRAFT, SPACE, LIFE SAVING, OR LIFE SUSTAINING APPLICATIONS, NOR IN PRODUCTS OR SYSTEMS WHERE FAILURE OR MALFUNCTION MAY RESULT IN PERSONAL INJURY, DEATH, OR SEVERE PROPERTY OR ENVIRONMENTAL DAMAGE. ST PRODUCTS WHICH ARE NOT SPECIFIED AS "AUTOMOTIVE GRADE" MAY ONLY BE USED IN AUTOMOTIVE APPLICATIONS AT USER'S OWN RISK.

Resale of ST products with provisions different from the statements and/or technical features set forth in this document shall immediately void any warranty granted by ST for the ST product or service described herein and shall not create or extend in any manner whatsoever, any liability of ST.

ST and the ST logo are trademarks or registered trademarks of ST in various countries.

Information in this document supersedes and replaces all information previously supplied.

The ST logo is a registered trademark of STMicroelectronics. All other names are the property of their respective owners.

© 2007 STMicroelectronics - All rights reserved

STMicroelectronics group of companies

Australia - Belgium - Brazil - Canada - China - Czech Republic - Finland - France - Germany - Hong Kong - India - Israel - Italy - Japan - Malaysia - Malta - Morocco - Singapore - Spain - Sweden - Switzerland - United Kingdom - United States of America

www.st.com