

MBRS20H100CT – MBRS20H200CT

20.0 AMPS. Surface Mount Schottky Barrier Rectifiers Switchmode Power Rectifiers

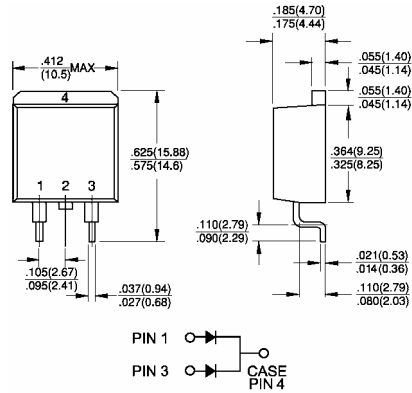

D²PAK



Dimensions in inches and (millimeters)

Features

- ✧ Plastic material used carries Underwriters Laboratory Classifications 94V-0
- ✧ Metal silicon junction, majority carrier conduction
- ✧ Low power loss, high efficiency
- ✧ High current capability, low forward voltage drop
- ✧ High surge capability
- ✧ For use in power supply – output rectification, power management, instrumentation
- ✧ Guardring for overvoltage protection
- ✧ High temperature soldering guaranteed: 260°C/10 seconds, 0.25" (6.35mm) from case

Mechanical Data

- ✧ Cases: D2PAK molded plastic
- ✧ Terminals: Pure tin plated, lead free. solderable per MIL-STD-750, Method 2026
- ✧ Polarity: As marked
- ✧ Mounting position: Any
- ✧ Mounting torque: 5 in. - lbs. max
- ✧ Weight: 0.08 ounce, 2.24 grams

Maximum Ratings and Electrical Characteristics

Rating at 25 °C ambient temperature unless otherwise specified.

Single phase, half wave, 60 Hz, resistive or inductive load.

For capacitive load, derate current by 20%

Type Number	Symbol	MBRS 20H100CT	MBRS 20H150CT	MBRS 20H200CT	Units
Maximum Recurrent Peak Reverse Voltage	V_{RRM}	100	150	200	V
Maximum RMS Voltage	V_{RMS}	70	105	140	V
Maximum DC Blocking Voltage	V_{DC}	100	150	200	V
Maximum Average Forward Rectified Current at $T_C=125^\circ\text{C}$	$I_{(AV)}$	20			A
Peak Repetitive Forward Current (Rated V_R , Square Wave, 20KHz) at $T_C=125^\circ\text{C}$	I_{FRM}	20			A
Peak Forward Surge Current, 8.3 ms Single Half Sine-wave Superimposed on Rated Load (JEDEC method)	I_{FSM}	150			A
Peak Repetitive Reverse Surge Current (Note 1)	I_{RRM}	1.0		0.5	A
Maximum Instantaneous Forward Voltage at: (Note 2) $I_F=10\text{A}, T_C=25^\circ\text{C}$ $I_F=10\text{A}, T_C=125^\circ\text{C}$ $I_F=20\text{A}, T_C=25^\circ\text{C}$ $I_F=20\text{A}, T_C=125^\circ\text{C}$	V_F	0.85 0.75 0.95 0.85	0.88 0.75 0.97 0.85		V
Maximum Instantaneous Reverse Current @ $T_C=25^\circ\text{C}$ at Rated DC Blocking Voltage @ $T_C=125^\circ\text{C}$ (Note 2)	I_R	5 2.0			uA mA
Voltage Rate of Change (Rated V_R)	dV/dt	10,000			V/uS
Maximum Typical Thermal Resistance (Note 3)	$R_{\theta JC}$	1.5			°C/W
Operating Junction Temperature Range	T_J	-65 to +175			°C
Storage Temperature Range	T_{STG}	-65 to +175			°C

- Notes:
1. 2.0us Pulse Width, $f=1.0\text{ KHz}$
 2. Pulse Test: 300us Pulse Width, 1% Duty Cycle
 3. Thermal Resistance from Junction to Case Per Leg, Mount on Heatsink Size of 2 in x 3 in x 0.25in Al-Plate.

RATINGS AND CHARACTERISTIC CURVES (MBRS20H100CT - MBRS20H200CT)

FIG.1- FORWARD CURRENT DERATING CURVE

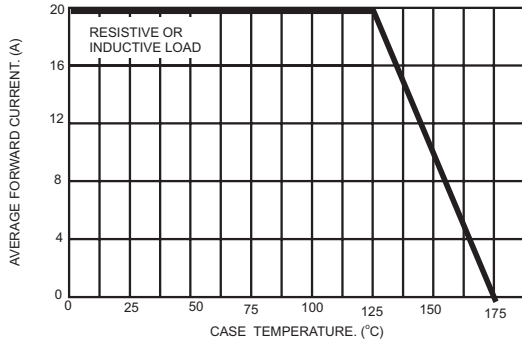

FIG.2- MAXIMUM NON-REPETITIVE FORWARD SURGE CURRENT PER LEG

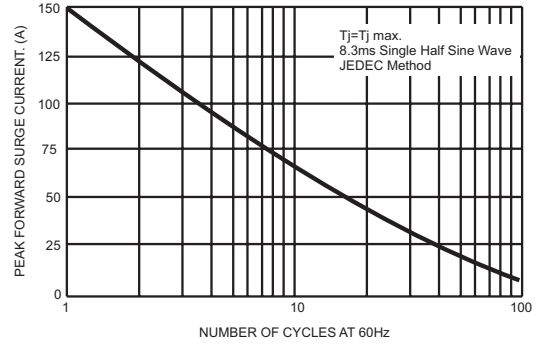

FIG.3- TYPICAL INSTANTANEOUS FORWARD CHARACTERISTICS PER LEG

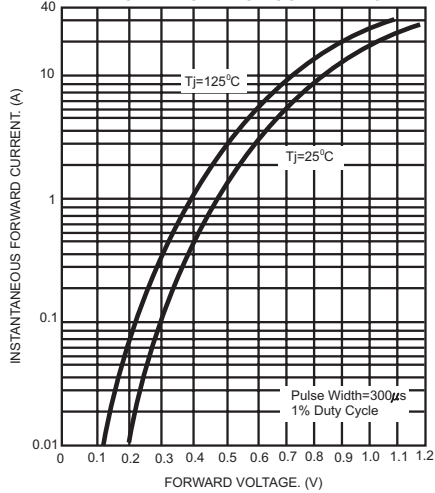

FIG.4- TYPICAL REVERSE CHARACTERISTICS PER LEG

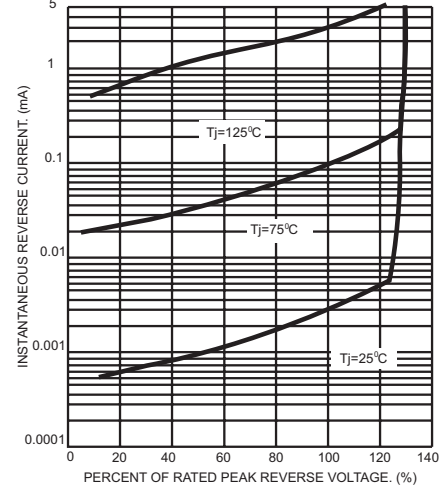

FIG.5- TYPICAL JUNCTION CAPACITANCE PER LEG

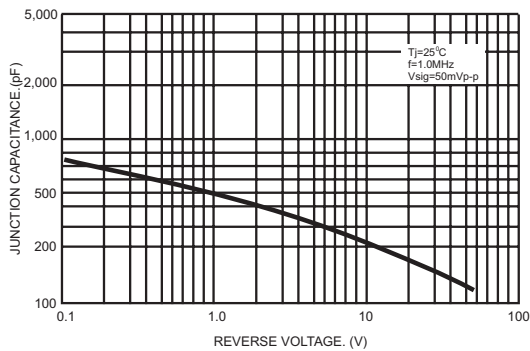

FIG.6- TYPICAL TRANSIENT THERMAL IMPEDANCE PER LEG

