

FEATURES

- **Compatible With HDMI v1.2a (Type A) DVI 1.0 High-Speed Digital Interface**
 - Wide Bandwidth of Over 1.65 Gbps (Bandwidth 1.9 Gbps Typ)
 - 165-MHz Speed Operation
 - Serial Data Stream at 10× Pixel Clock Rate
 - Supports All Video Formats up to 1080p and SXGA (1280 × 1024 at 75 Hz)
 - Total Raw Capacity 4.95 Gbps (Single Link)
 - HDCP Compatible
- **Low Crosstalk ($X_{TALK} = -37$ dB Typ)**
- **Low Bit-to-Bit Skew ($t_{sk(o)} = 0.1$ ns Max)**
- **Low and Flat ON-State Resistance ($r_{on} = 4$ Ω Typ, $r_{on(Flat)} = 0.5$ Ω Typ)**
- **Low Input/Output Capacitance ($C_{ON} = 8$ pF Typ)**
- **Rail-to-Rail Switching on Data I/O Ports (0 to 3.6 V)**
- **V_{CC} Operating Range From 3 V to 3.6 V**
- **I_{off} Supports Partial-Power-Down Mode Operation ($V_{CC} = V_{IN} = 0$ V)**
- **Latch-Up Performance Exceeds 100 mA Per JESD 78, Class II**
- **ESD Performance Tested Per JESD 22**
 - 14000-V Human-Body Model (A114-B, Class II)

**TQFN PACKAGE
(TOP VIEW)**

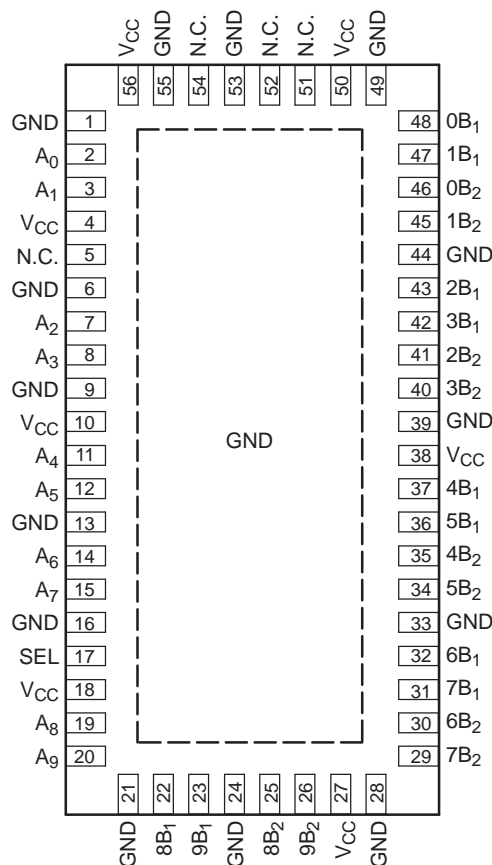

N.C. – No internal connection

APPLICATIONS

- **DVI/HDMI Signal Switching**
- **Differential DVI, HDMI Signal Multiplexing for Audio/Video Receivers and High-Definition Televisions (HDTVs)**

DESCRIPTION/ORDERING INFORMATION

The TS3DV520E is a 20-bit to 10-bit multiplexer/demultiplexer digital video switch with a single select (SEL) input. SEL controls the data path of the multiplexer/demultiplexer. The device provides five differential channels for digital video signal switching.

This device provides low and flat ON-state resistance (r_{on}) and excellent ON-state resistance match. Low input/output capacitance, high bandwidth, low skew, and low crosstalk among channels make this device suitable for various digital video applications, such as DVI and HDMI.

This device is specified for partial-power-down applications using I_{off} . The I_{off} feature ensures that damaging current will not backflow through the device when it is powered down. The device has isolation during power off.

Voltage on the SEL pin should be less or equal to V_{CC} , even in the power-down mode ($V_{CC} = 0$ V).



Please be aware that an important notice concerning availability, standard warranty, and use in critical applications of Texas Instruments semiconductor products and disclaimers thereto appears at the end of this data sheet.

TS3DV520E 5-CHANNEL DIFFERENTIAL 10:20 MULTIPLEXER SWITCH FOR DVI/HDMI APPLICATIONS

SCDS240 JUNE 2007
[查询SD520E"供应商](#)

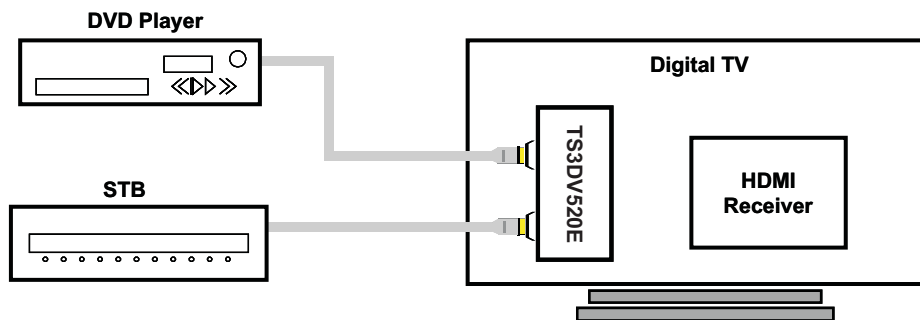

ORDERING INFORMATION

T _A	PACKAGE ⁽¹⁾⁽²⁾		ORDERABLE PART NUMBER	TOP-SIDE MARKING
-40°C to 85°C	TQFN	Reel of 2000	TS3DV520ERHURG4	SD520E

- (1) Package drawings, standard packing quantities, thermal data, symbolization, and PCB design guidelines are available at www.ti.com/sc/package.
- (2) For the most current package and ordering information, see the Package Option Addendum at the end of this document, or see the TI website at www.ti.com.

FUNCTION TABLE

INPUT SEL	INPUT/OUTPUT A _n	FUNCTION	
L	nB ₁	A _n = nB ₁	nB ₂ high-impedance mode
H	nB ₂	A _n = nB ₂	nB ₁ high-impedance mode

PIN DESCRIPTION

NAME	DESCRIPTION
A _n	Data I/O
nB _m	Data I/O
SEL	Select input

LOGIC DIAGRAM (POSITIVE LOGIC)

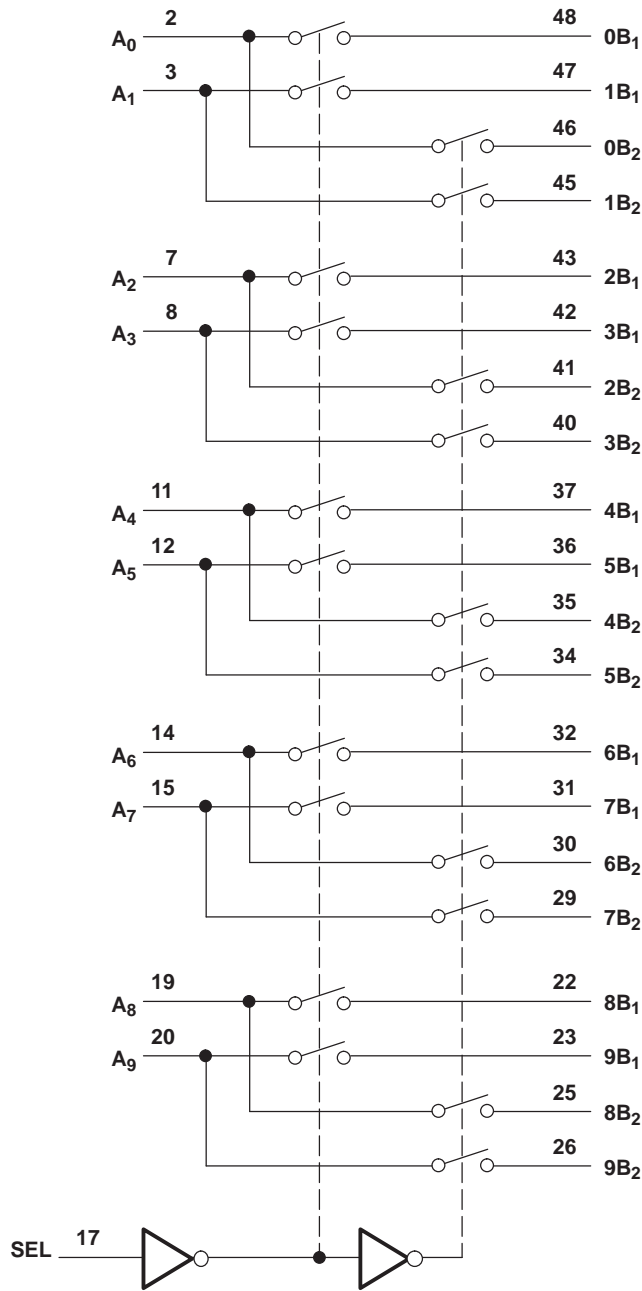

TS3DV520E

5-CHANNEL DIFFERENTIAL 10:20 MULTIPLEXER SWITCH FOR DVI/HDMI APPLICATIONS

SCBS240 JUNE 2007
[查询“TS3DV520E”供应商](#)

Absolute Maximum Ratings⁽¹⁾

over operating free-air temperature range (unless otherwise noted)

		MIN	MAX	UNIT
V _{CC}	Supply voltage range	-0.5	4.6	V
V _{IN}	Control input voltage range ⁽²⁾⁽³⁾	-0.5	V _{CC} + 0.5	V
V _{I/O}	Switch I/O voltage range ⁽²⁾⁽³⁾⁽⁴⁾	-0.5	7	V
I _{IK}	Control input clamp current	V _{IN} < 0	-50	mA
I _{I/O} K	I/O port clamp current	V _{I/O} < 0	-50	mA
I _{I/O}	ON-state switch current ⁽⁵⁾		±128	mA
	Continuous current through V _{CC} or GND		±100	mA
θ _{JA}	Package thermal impedance ⁽⁶⁾		31.8	°C/W
T _{stg}	Storage temperature range	-65	150	°C

- (1) Stresses beyond those listed under "absolute maximum ratings" may cause permanent damage to the device. These are stress ratings only, and functional operation of the device at these or any other conditions beyond those indicated under "recommended operating conditions" is not implied. Exposure to absolute-maximum-rated conditions for extended periods may affect device reliability.
- (2) All voltages are with respect to ground, unless otherwise specified.
- (3) The input and output voltage ratings may be exceeded if the input and output clamp-current ratings are observed.
- (4) V_I and V_O are used to denote specific conditions for V_{I/O}.
- (5) I_I and I_O are used to denote specific conditions for I_{I/O}.
- (6) The package thermal impedance is calculated in accordance with JESD 51-7.

Recommended Operating Conditions⁽¹⁾

		MIN	MAX	UNIT
V _{CC}	Supply voltage	3	3.6	V
V _{IH}	High-level control input voltage (SEL)	2	V _{CC}	V
V _{IL}	Low-level control input voltage (SEL)	0	0.8	V
V _{I/O}	Input/output voltage	0	5.5	V
T _A	Operating free-air temperature	-40	85	°C

- (1) All unused control inputs of the device must be held at V_{CC} or GND to ensure proper device operation. Refer to the TI application report, *Implications of Slow or Floating CMOS Inputs*, literature number SCBA004.

Electrical Characteristics⁽¹⁾

for high-frequency switching over recommended operating free-air temperature range, $V_{CC} = 3.3 \text{ V} \pm 0.3 \text{ V}$
(unless otherwise noted)

PARAMETER		TEST CONDITIONS			MIN	TYP ⁽²⁾	MAX	UNIT
V_{IK}	SEL	$V_{CC} = 3.6 \text{ V}$, $I_{IN} = -18 \text{ mA}$				-0.7	-1.2	V
I_{IH}	SEL	$V_{CC} = 3.6 \text{ V}$, $V_{IN} = V_{CC}$					± 1	μA
I_{IL}	SEL	$V_{CC} = 3.6 \text{ V}$, $V_{IN} = \text{GND}$					± 1	μA
I_{off}		$V_{CC} = 0$,	$V_O = 0 \text{ to } 3.6 \text{ V}$,	$V_I = 0$,			1	μA
I_{CC}		$V_{CC} = 3.6 \text{ V}$, $I_{IO} = 0$, Switch ON or OFF				250	600	μA
C_{IN}	SEL	$f = 1 \text{ MHz}$, $V_{IN} = 0$				2	2.5	pF
C_{OFF}	B port	$V_I = 0$,	$f = 1 \text{ MHz}$,	Outputs open, Switch OFF		3	4	pF
C_{ON}		$V_I = 0$,	$f = 1 \text{ MHz}$,	Outputs open, Switch ON		9	9.8	pF
r_{on}		$V_{CC} = 3 \text{ V}$,	$1.5 \text{ V} \leq V_I \leq V_{CC}$,	$I_O = -40 \text{ mA}$		4	8	Ω
$r_{on(\text{flat})}$ ⁽³⁾		$V_{CC} = 3 \text{ V}$,	$V_I = 1.5 \text{ V}$ and V_{CC} ,	$I_O = -40 \text{ mA}$		0.7		Ω
Δr_{on} ⁽⁴⁾		$V_{CC} = 3 \text{ V}$,	$1.5 \text{ V} \leq V_I \leq V_{CC}$,	$I_O = -40 \text{ mA}$		0.2	1.2	Ω

- (1) V_I , V_O , I_I , and I_O refer to I/O pins. V_{IN} refers to the control inputs.
(2) All typical values are at $V_{CC} = 3.3 \text{ V}$ (unless otherwise noted), $T_A = 25^\circ\text{C}$.
(3) $r_{on(\text{flat})}$ is the difference of r_{on} in a given channel at specified voltages.
(4) Δr_{on} is the difference of r_{on} from center (A_4 , A_5) ports to any other port.

Switching Characteristics

over recommended operating free-air temperature range, $V_{CC} = 3.3 \text{ V} \pm 0.3 \text{ V}$, $R_L = 200 \Omega$, $C_L = 10 \text{ pF}$
(unless otherwise noted) (see [Figure 5](#) and [Figure 6](#))

PARAMETER	FROM (INPUT)	TO (OUTPUT)	MIN	TYP ⁽¹⁾	MAX	UNIT
t_{pd} ⁽²⁾	A or B	B or A		0.25		ns
t_{pZH} , t_{pZL}	SEL	A or B	0.5		15	ns
t_{pHZ} , t_{pLZ}	SEL	A or B	0.5		9	ns
$t_{sk(o)}$ ⁽³⁾	A or B	B or A		0.05	0.1	ns
$t_{sk(p)}$ ⁽⁴⁾				0.05	0.1	ns

- (1) All typical values are at $V_{CC} = 3.3 \text{ V}$ (unless otherwise noted), $T_A = 25^\circ\text{C}$.
(2) The propagation delay is the calculated RC time constant of the typical ON-state resistance of the switch and the specified load capacitance when driven by an ideal voltage source (zero output impedance).
(3) Output skew between center port (A_4 to A_5) to any other port
(4) Skew between opposite transitions of the same output in a given device $|t_{pHL} - t_{pLH}|$

Dynamic Characteristics

over recommended operating free-air temperature range, $V_{CC} = 3.3 \text{ V} \pm 0.3 \text{ V}$ (unless otherwise noted)

PARAMETER	TEST CONDITIONS			TYP ⁽¹⁾	UNIT
X_{TALK}	$R_L = 100 \Omega$,	$f = 250 \text{ MHz}$,	See Figure 8	-37	dB
O_{IRR}	$R_L = 100 \Omega$,	$f = 250 \text{ MHz}$,	See Figure 9	-37	dB
BW	$R_L = 100 \Omega$,	See Figure 7		950	MHz

- (1) All typical values are at $V_{CC} = 3.3 \text{ V}$ (unless otherwise noted), $T_A = 25^\circ\text{C}$.

OPERATING CHARACTERISTICS

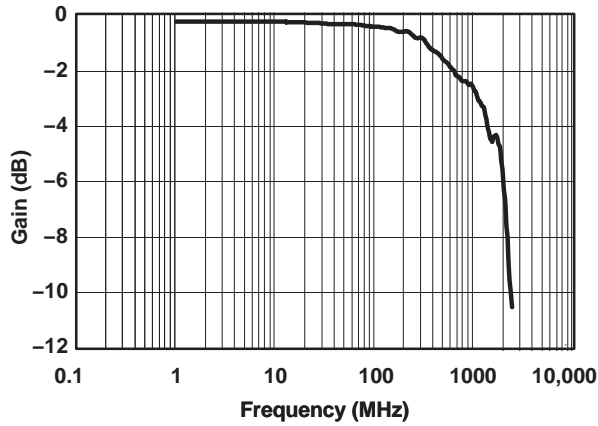

Figure 1. Gain/Phase vs Frequency

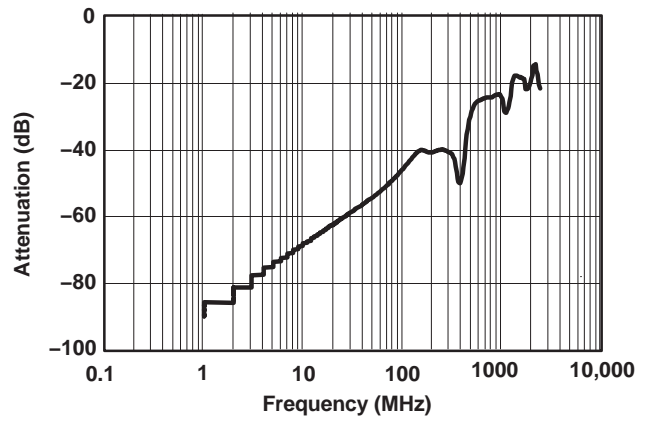

Figure 2. OFF Isolation vs Frequency

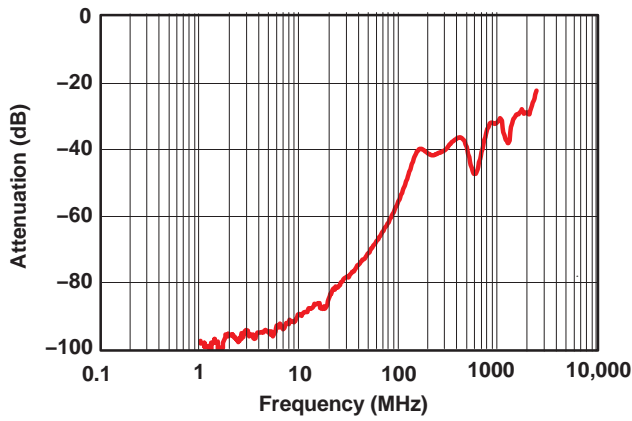

Figure 3. Crosstalk vs Frequency

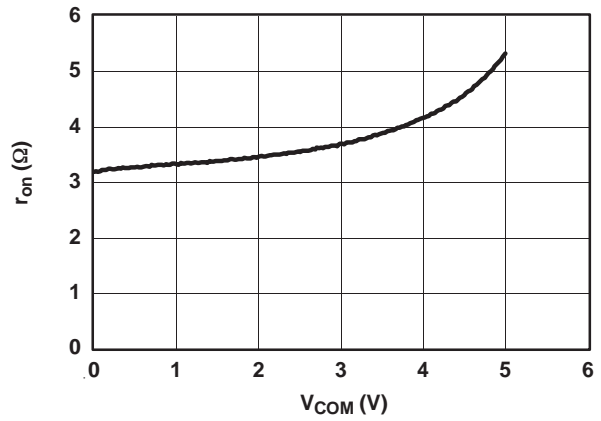
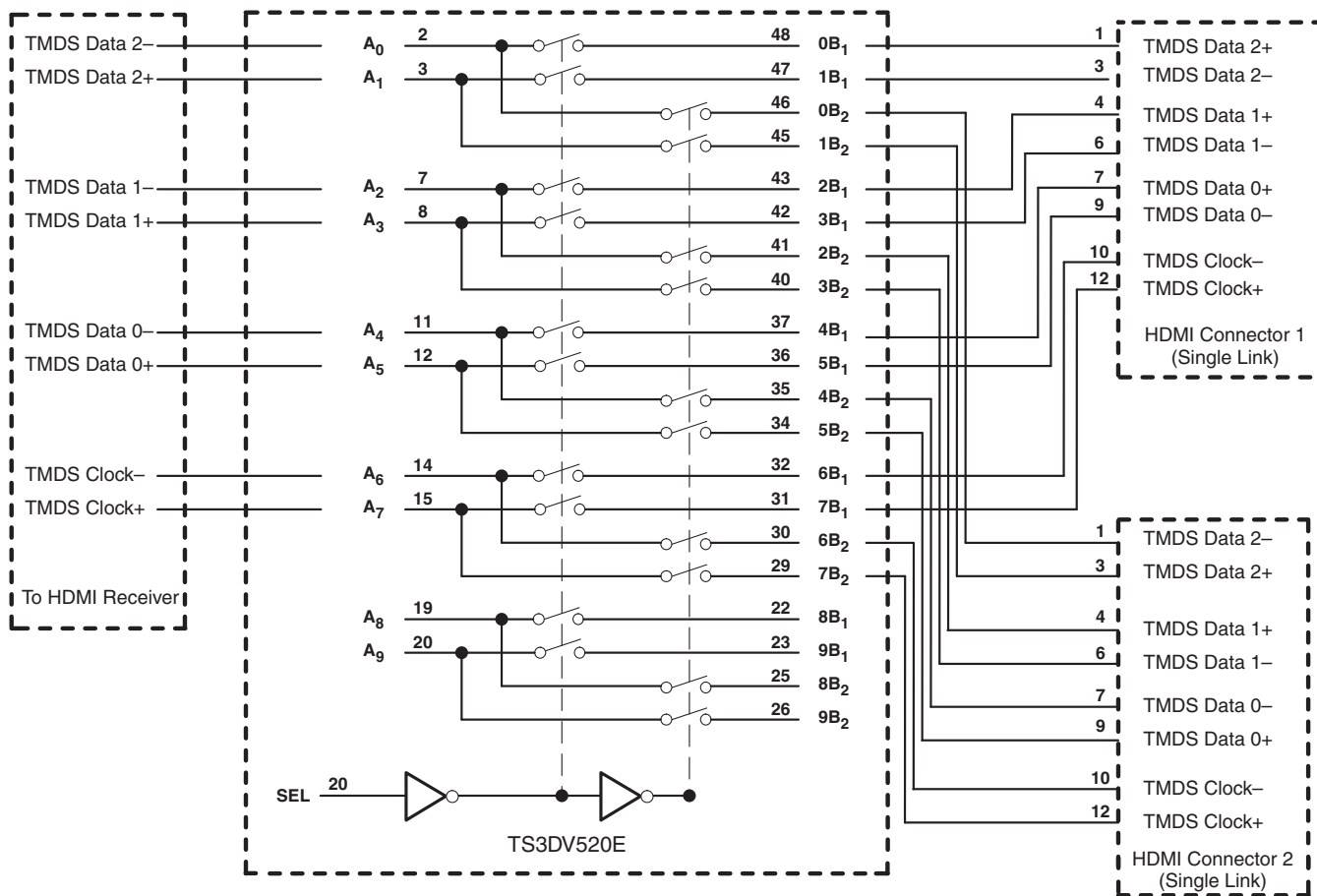
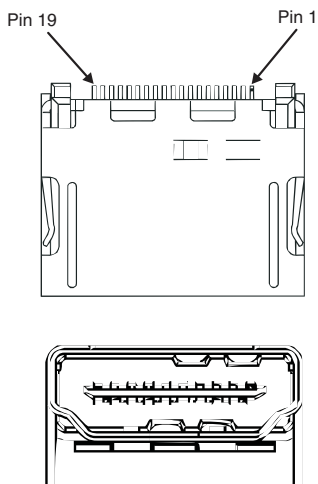

Figure 4. r_{on} and V_0 vs V_1

APPLICATION INFORMATION



Typical HDMI Connector



The TS3DV520E can be used to switch between two digital video ports.

Pin	Signal Assignment
1	TMDS Data 2+
2	TMDS Data 2 Shield
3	TMDS Data 2-
4	TMDS Data 1+
5	TMDS Data 1 Shield
6	TMDS Data 1-
7	TMDS Data 0+
8	TMDS Data 0 Shield
9	TMDS Data 0-
10	TMDS Clock+
11	TMDS Clock Shield
12	TMDS Clock-
13	CEC
14	Reserved (N.C. on device)
15	SCL
16	SDA
17	DDC/CEC Ground
18	5 V Power
19	Hot Plug Detect

TS3DV520E 5-CHANNEL DIFFERENTIAL 10:20 MULTIPLEXER SWITCH FOR DVI/HDMI APPLICATIONS

SCDS240 JUNE 2007
查询SD520E 供应商

PARAMETER MEASUREMENT INFORMATION (Enable and Disable Times)

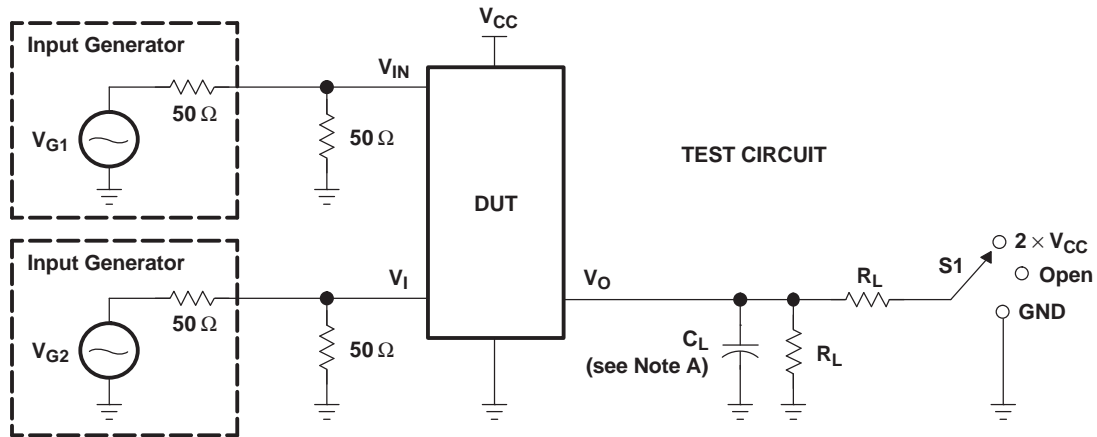

TEST	V_{CC}	S1	R_L	V_I	C_L	V_{Δ}
t_{PLZ}/t_{PZL}	$3.3\text{ V} \pm 0.3\text{ V}$	$2 \times V_{CC}$	$200\ \Omega$	GND	10 pF	0.3 V
t_{PHZ}/t_{PZH}	$3.3\text{ V} \pm 0.3\text{ V}$	GND	$200\ \Omega$	V_{CC}	10 pF	0.3 V

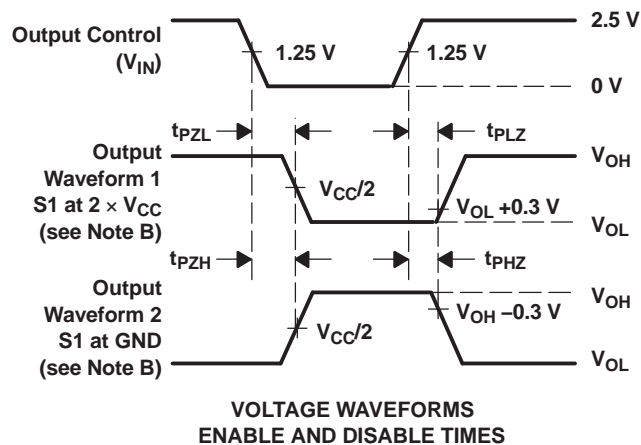

- NOTES: A. C_L includes probe and jig capacitance.
 B. Waveform 1 is for an output with internal conditions such that the output is low, except when disabled by the output control. Waveform 2 is for an output with internal conditions such that the output is high, except when disabled by the output control.
 C. All input pulses are supplied by generators having the following characteristics: $PRR \leq 10\text{ MHz}$, $Z_O = 50\ \Omega$, $t_r \leq 2.5\text{ ns}$, $t_f \leq 2.5\text{ ns}$.
 D. The outputs are measured one at a time, with one transition per measurement.
 E. t_{PLZ} and t_{PHZ} are the same as t_{dis} .
 F. t_{PZL} and t_{PZH} are the same as t_{en} .

Figure 5. Test Circuit and Voltage Waveforms

PARAMETER MEASUREMENT INFORMATION
(Skew)

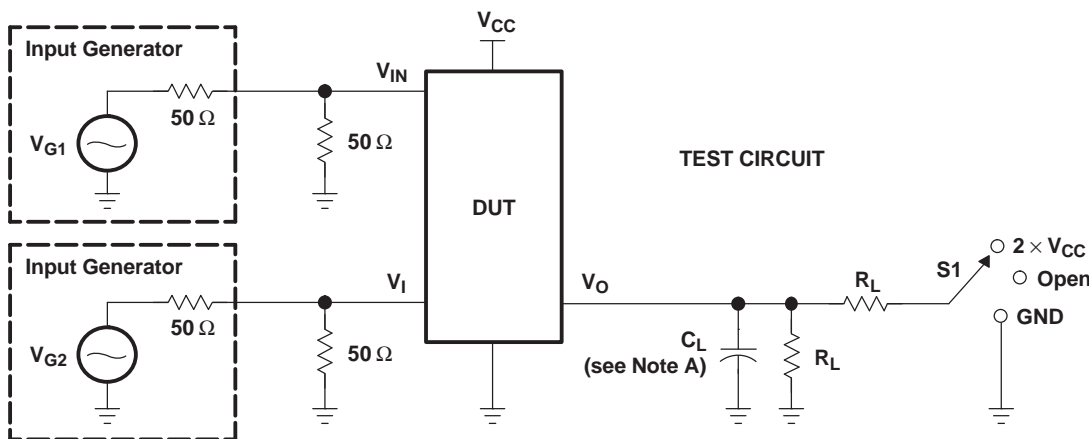

TEST	V _{CC}	S1	R _L	V _I	C _L	V _Δ
t _{sk(o)}	3.3 V ± 0.3 V	Open	200 Ω	V _{CC} or GND	10 pF	
t _{sk(p)}	3.3 V ± 0.3 V	Open	200 Ω	V _{CC} or GND	10 pF	

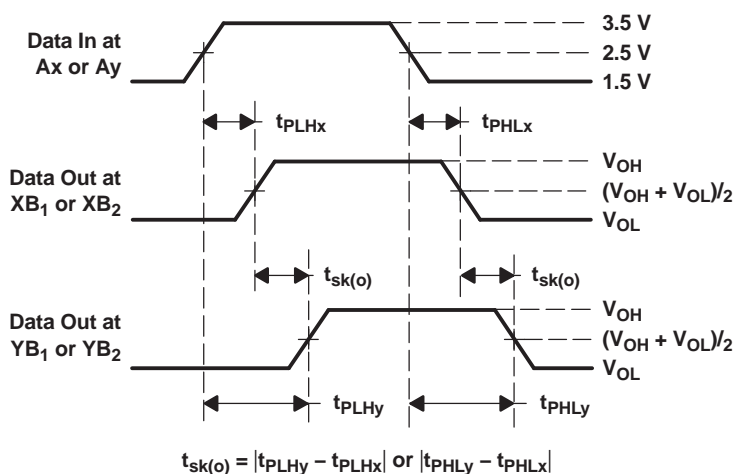

VOLTAGE WAVEFORMS
OUTPUT SKEW (t_{sk(o)})

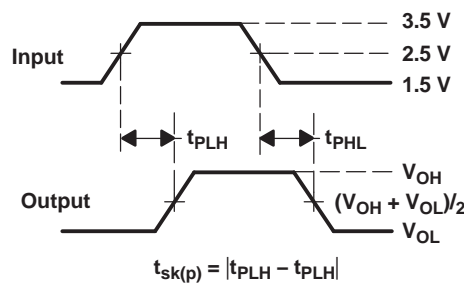

VOLTAGE WAVEFORMS
PULSE SKEW (t_{sk(p)})

- NOTES:
- C_L includes probe and jig capacitance.
 - Waveform 1 is for an output with internal conditions such that the output is low, except when disabled by the output control. Waveform 2 is for an output with internal conditions such that the output is high, except when disabled by the output control.
 - All input pulses are supplied by generators having the following characteristics: PRR ≤ 10 MHz, Z_O = 50 Ω, t_r ≤ 2.5 ns, t_f ≤ 2.5 ns.
 - The outputs are measured one at a time, with one transition per measurement.

Figure 6. Test Circuit and Voltage Waveforms

PARAMETER MEASUREMENT INFORMATION

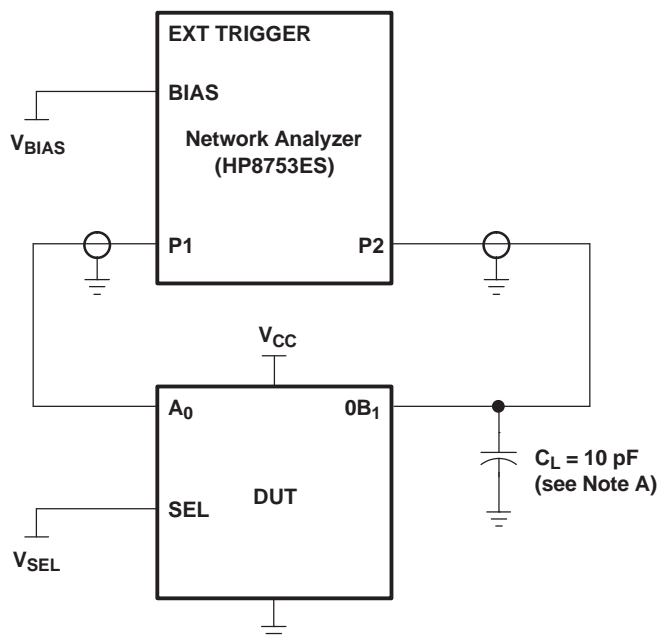

NOTE A: C_L includes probe and jig capacitance.

Figure 7. Test Circuit for Frequency Response (BW)

Frequency response is measured at the output of the ON channel. For example, when $V_{SEL} = 0$ and A_0 is the input, the output is measured at $0B_1$. All unused analog I/O ports are left open.

HP8753ES setup

Average = 4

RBW = 3 kHz

$V_{BIAS} = 0.35$ V

ST = 2 s

P1 = 0 dBm

PARAMETER MEASUREMENT INFORMATION

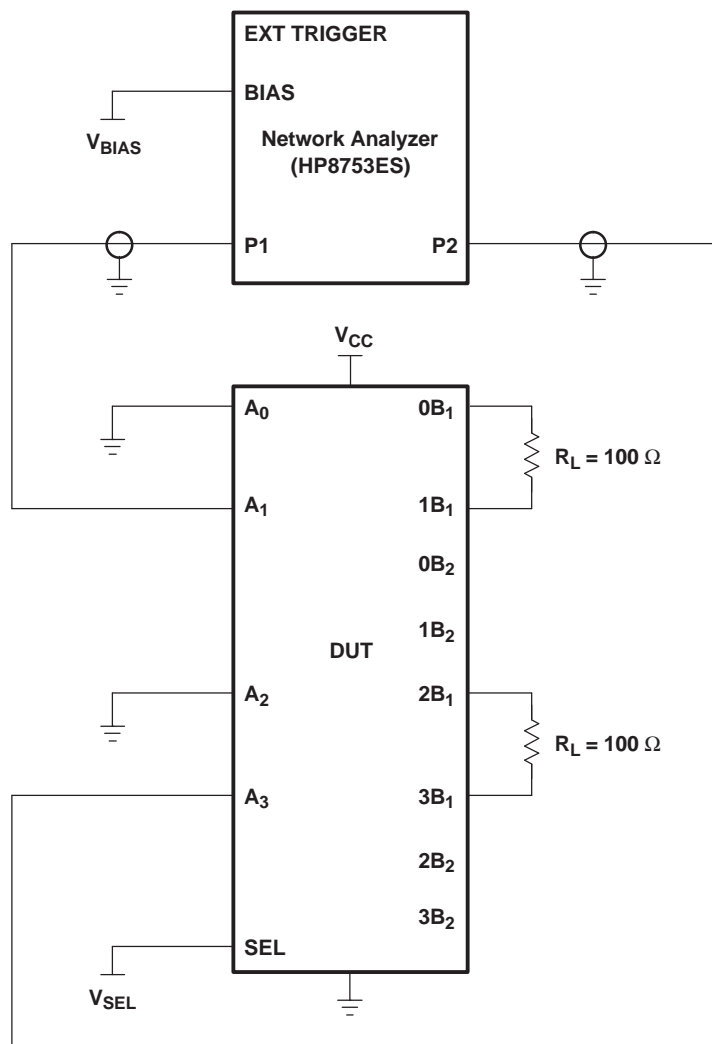

- NOTES: A. C_L includes probe and jig capacitance.
 B. A 50- Ω termination resistor is needed to match the loading of the network analyzer.

Figure 8. Test Circuit for Crosstalk (X_{TALK})

Crosstalk is measured at the output of the nonadjacent ON channel. For example, when $V_{SEL} = 0$ and A_0 is the input, the output is measured at $1B_1$. All unused analog input (A) ports are connected to GND, and output (B) ports are connected to GND through 50- Ω pulldown resistors.

HP8753ES setup

- Average = 4
- RBW = 3 kHz
- $V_{BIAS} = 0.35$ V
- ST = 2 s
- P1 = 0 dBm

PARAMETER MEASUREMENT INFORMATION

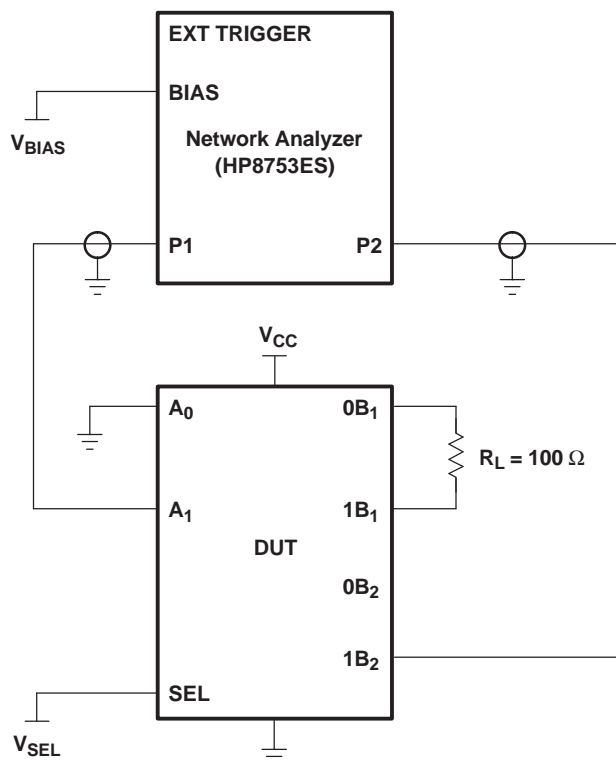

- NOTES: A. C_L includes probe and jig capacitance.
B. A 50- Ω termination resistor is needed to match the loading of the network analyzer.

Figure 9. Test Circuit for OFF Isolation (O_{IRR})

OFF isolation is measured at the output of the OFF channel. For example, when $V_{SEL} = V_{CC}$ and A_0 is the input, the output is measured at $0B_2$. All unused analog input (A) ports are left open, and output (B) ports are connected to GND through 50- Ω pulldown resistors.

HP8753ES setup

Average = 4

RBW = 3 kHz

$V_{BIAS} = 0.35$ V

ST = 2

P1 = 0 dBm

PACKAGING INFORMATION

Orderable Device	Status ⁽¹⁾	Package Type	Package Drawing	Pins	Package Qty	Eco Plan ⁽²⁾	Lead/Ball Finish	MSL Peak Temp ⁽³⁾
TS3DV520ERHURG4	ACTIVE	WQFN	RHU	56	2000	Green (RoHS & no Sb/Br)	CU NIPDAU	Level-1-260C-UNLIM

⁽¹⁾ The marketing status values are defined as follows:

ACTIVE: Product device recommended for new designs.

LIFEBUY: TI has announced that the device will be discontinued, and a lifetime-buy period is in effect.

NRND: Not recommended for new designs. Device is in production to support existing customers, but TI does not recommend using this part in a new design.

PREVIEW: Device has been announced but is not in production. Samples may or may not be available.

OBSOLETE: TI has discontinued the production of the device.

⁽²⁾ Eco Plan - The planned eco-friendly classification: Pb-Free (RoHS), Pb-Free (RoHS Exempt), or Green (RoHS & no Sb/Br) - please check <http://www.ti.com/productcontent> for the latest availability information and additional product content details.

TBD: The Pb-Free/Green conversion plan has not been defined.

Pb-Free (RoHS): TI's terms "Lead-Free" or "Pb-Free" mean semiconductor products that are compatible with the current RoHS requirements for all 6 substances, including the requirement that lead not exceed 0.1% by weight in homogeneous materials. Where designed to be soldered at high temperatures, TI Pb-Free products are suitable for use in specified lead-free processes.

Pb-Free (RoHS Exempt): This component has a RoHS exemption for either 1) lead-based flip-chip solder bumps used between the die and package, or 2) lead-based die adhesive used between the die and leadframe. The component is otherwise considered Pb-Free (RoHS compatible) as defined above.

Green (RoHS & no Sb/Br): TI defines "Green" to mean Pb-Free (RoHS compatible), and free of Bromine (Br) and Antimony (Sb) based flame retardants (Br or Sb do not exceed 0.1% by weight in homogeneous material)

⁽³⁾ MSL, Peak Temp. -- The Moisture Sensitivity Level rating according to the JEDEC industry standard classifications, and peak solder temperature.

Important Information and Disclaimer:The information provided on this page represents TI's knowledge and belief as of the date that it is provided. TI bases its knowledge and belief on information provided by third parties, and makes no representation or warranty as to the accuracy of such information. Efforts are underway to better integrate information from third parties. TI has taken and continues to take reasonable steps to provide representative and accurate information but may not have conducted destructive testing or chemical analysis on incoming materials and chemicals. TI and TI suppliers consider certain information to be proprietary, and thus CAS numbers and other limited information may not be available for release.

In no event shall TI's liability arising out of such information exceed the total purchase price of the TI part(s) at issue in this document sold by TI to Customer on an annual basis.

[查询"SD520E"供应商](#)

RHU (R-PQFP-N56)

PLASTIC QUAD FLATPACK

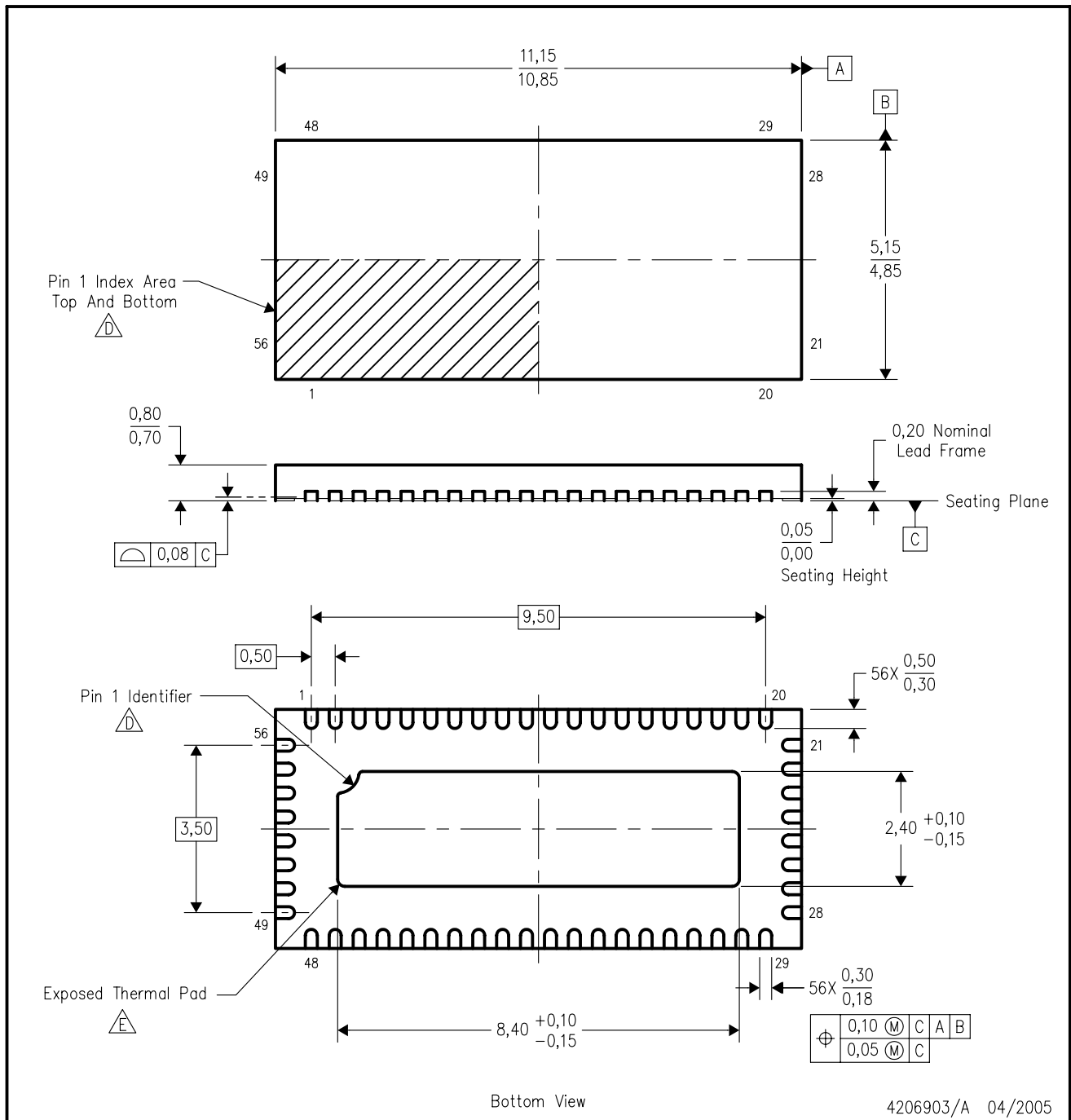

- Notes:
- A. All linear dimensions are in millimeters. Dimensioning and tolerancing per ASME Y14.5M-1994.
 - B. This drawing is subject to change without notice.
 - C. QFN (Quad Flatpack No-Lead) package configuration.
 - D** Pin 1 identifiers are located on both top and bottom of the package and within the zone indicated. The Pin 1 identifiers are either a molded, marked, or metal feature.
 - E** The package thermal pad must be soldered to the board for thermal and mechanical performance.
 - F. JEDEC MO-220 package registration is pending.

IMPORTANT NOTICE

Texas Instruments Incorporated and its subsidiaries (TI) reserve the right to make corrections, modifications, enhancements, improvements, and other changes to its products and services at any time and to discontinue any product or service without notice. Customers should obtain the latest relevant information before placing orders and should verify that such information is current and complete. All products are sold subject to TI's terms and conditions of sale supplied at the time of order acknowledgment.

TI warrants performance of its hardware products to the specifications applicable at the time of sale in accordance with TI's standard warranty. Testing and other quality control techniques are used to the extent TI deems necessary to support this warranty. Except where mandated by government requirements, testing of all parameters of each product is not necessarily performed.

TI assumes no liability for applications assistance or customer product design. Customers are responsible for their products and applications using TI components. To minimize the risks associated with customer products and applications, customers should provide adequate design and operating safeguards.

TI does not warrant or represent that any license, either express or implied, is granted under any TI patent right, copyright, mask work right, or other TI intellectual property right relating to any combination, machine, or process in which TI products or services are used. Information published by TI regarding third-party products or services does not constitute a license from TI to use such products or services or a warranty or endorsement thereof. Use of such information may require a license from a third party under the patents or other intellectual property of the third party, or a license from TI under the patents or other intellectual property of TI.

Reproduction of TI information in TI data books or data sheets is permissible only if reproduction is without alteration and is accompanied by all associated warranties, conditions, limitations, and notices. Reproduction of this information with alteration is an unfair and deceptive business practice. TI is not responsible or liable for such altered documentation. Information of third parties may be subject to additional restrictions.

Resale of TI products or services with statements different from or beyond the parameters stated by TI for that product or service voids all express and any implied warranties for the associated TI product or service and is an unfair and deceptive business practice. TI is not responsible or liable for any such statements.

TI products are not authorized for use in safety-critical applications (such as life support) where a failure of the TI product would reasonably be expected to cause severe personal injury or death, unless officers of the parties have executed an agreement specifically governing such use. Buyers represent that they have all necessary expertise in the safety and regulatory ramifications of their applications, and acknowledge and agree that they are solely responsible for all legal, regulatory and safety-related requirements concerning their products and any use of TI products in such safety-critical applications, notwithstanding any applications-related information or support that may be provided by TI. Further, Buyers must fully indemnify TI and its representatives against any damages arising out of the use of TI products in such safety-critical applications.

TI products are neither designed nor intended for use in military/aerospace applications or environments unless the TI products are specifically designated by TI as military-grade or "enhanced plastic." Only products designated by TI as military-grade meet military specifications. Buyers acknowledge and agree that any such use of TI products which TI has not designated as military-grade is solely at the Buyer's risk, and that they are solely responsible for compliance with all legal and regulatory requirements in connection with such use.

TI products are neither designed nor intended for use in automotive applications or environments unless the specific TI products are designated by TI as compliant with ISO/TS 16949 requirements. Buyers acknowledge and agree that, if they use any non-designated products in automotive applications, TI will not be responsible for any failure to meet such requirements.

Following are URLs where you can obtain information on other Texas Instruments products and application solutions:

Products

Amplifiers	amplifier.ti.com
Data Converters	dataconverter.ti.com
DSP	dsp.ti.com
Clocks and Timers	www.ti.com/clocks
Interface	interface.ti.com
Logic	logic.ti.com
Power Mgmt	power.ti.com
Microcontrollers	microcontroller.ti.com
RFID	www.ti-rfid.com
RF/IF and ZigBee® Solutions	www.ti.com/lprf

Applications

Audio	www.ti.com/audio
Automotive	www.ti.com/automotive
Broadband	www.ti.com/broadband
Digital Control	www.ti.com/digitalcontrol
Medical	www.ti.com/medical
Military	www.ti.com/military
Optical Networking	www.ti.com/opticalnetwork
Security	www.ti.com/security
Telephony	www.ti.com/telephony
Video & Imaging	www.ti.com/video
Wireless	www.ti.com/wireless