

2 W Constant Output Power Class-D Audio Amplifier With Adaptive Boost Converter and Battery Tracking SpeakerGuard™ AGC

Check for Samples: [TPA2015D1](#)

FEATURES

- Built-In SpeakerGuard™ Automatic Gain Control (AGC) with Enhanced Battery Tracking
 - Limits Battery Current Consumption
 - Prevents Audio Clipping
- 2 W into 8 Ω Load From 3.6 V Supply (6% THD)
- Integrated Adaptive Boost Converter
 - Increases Efficiency at Low Output Power
- Low Quiescent Current of 1.7 mA from 3.6 V
- Operates From 2.5 V to 5.2 V
- Thermal and Short-Circuit Protection with Auto Recovery
- Three Gain Settings: 6 dB, 15.5 dB, and 20 dB
- Independent Control for Boost and Class-D
- Pin-to-Pin Compatible with TPA2013D1
- Available in 1.954 mm × 1.954 mm 16-ball WCSP Package

APPLICATIONS

- Cell Phones, PDA, GPS
- Portable Electronics and Speakers

SIMPLIFIED APPLICATION DIAGRAM

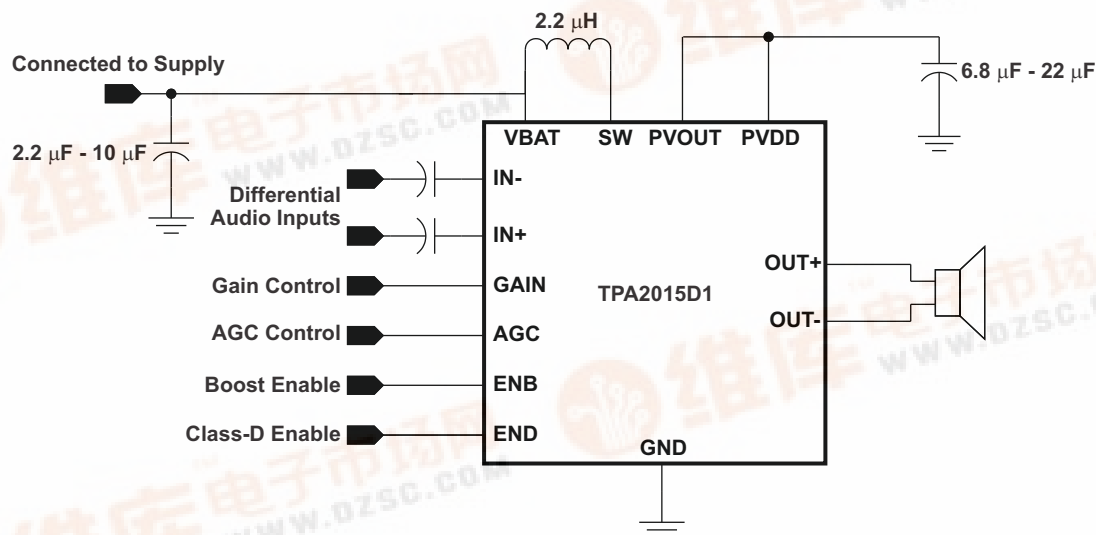

DESCRIPTION

The TPA2015D1 is a high efficiency Class-D audio power amplifier with battery-tracking SpeakerGuard™ AGC technology and an integrated adaptive boost converter that enhances efficiency at low output power. It drives up to 2 W into an 8 Ω speaker (6% THD). With 85% typical efficiency, the TPA2015D1 helps extend battery life when playing audio.

The built-in boost converter generates a 5.5 V supply voltage for the Class-D amplifier. This provides a louder audio output than a stand-alone amplifier directly connected to the battery. The SpeakerGuard™ AGC adjusts the Class-D gain to limit battery current and prevent heavy clipping.

The TPA2015D1 has an integrated low-pass filter to improve the RF rejection and reduce DAC out-of-band noise, increasing the signal to noise ratio (SNR).

The TPA2015D1 is available in a space saving 1.954 mm × 1.954 mm, 0.5 mm pitch WCSP package (YZH).

Please be aware that an important notice concerning availability, standard warranty, and use in critical applications of Texas Instruments semiconductor products and disclaimers thereto appears at the end of this data sheet.

SpeakerGuard is a trademark of Texas Instruments.

PRODUCTION DATA information is current as of publication date. Products conform to specifications per the terms of the Texas Instruments standard warranty. Production processing does not necessarily include testing of all parameters.

Copyright © 2010, Texas Instruments Incorporated





These devices have limited built-in ESD protection. The leads should be shorted together or the device placed in conductive foam during storage or handling to prevent electrostatic damage to the MOS gates.

FUNCTIONAL BLOCK DIAGRAM

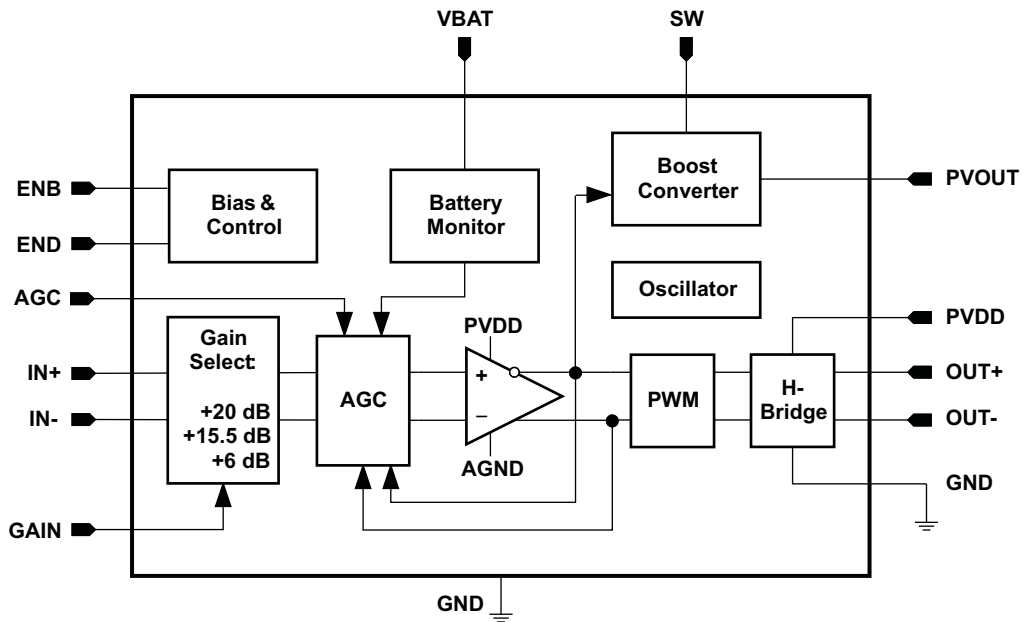

DEVICE PINOUT

WCSP (YZH) PACKAGE
 (TOP VIEW)
 Symbol Side

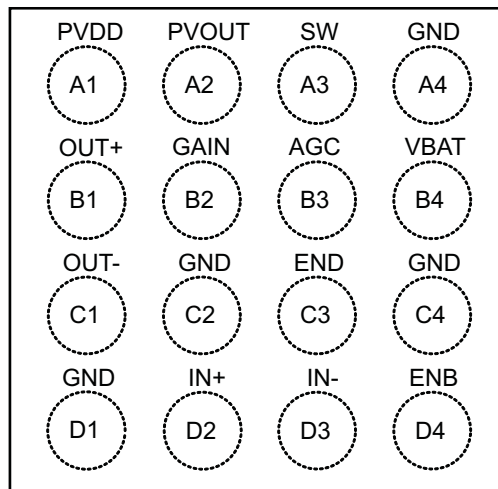

PIN FUNCTIONS

PIN		INPUT/ OUTPUT/ POWER (I/O/P)	DESCRIPTION
NAME	WCSP		
PVDD	A1	I	Class-D power stage supply voltage.
PVOUT	A2	O	Boost converter output.
SW	A3	I	Boost and rectifying switch input.
GND	A4, C2, C4, D1	P	Ground; all ground balls must be connected for proper functionality.
OUT+	B1	O	Positive audio output.
GAIN	B2	I	Gain selection pin.
AGC	B3	I	Enable and select AGC.
VBAT	B4	P	Supply voltage.
OUT–	C1	O	Negative audio output.
END	C3	I	Enable for the Class-D amplifier; set to logic high to enable.
IN+	D2	I	Positive audio input.
IN–	D3	I	Negative audio input.
ENB	D4	I	Enable for the boost converter; set to logic high to enable.

ORDERING INFORMATION

T _A	PACKAGED DEVICES ⁽¹⁾	PART NUMBER ⁽²⁾	SYMBOL
–40°C to 85°C	16-ball, 1.954mm x 1.954 mm WSCP	TPA2015D1YZHR	OEN
	16-ball, 1.954 mm x 1.954 mm WSCP	TPA2015D1YZHT	OEN

- (1) For the most current package and ordering information, see the Package Option Addendum at the end of this document, or see the TI Web site at www.ti.com.
- (2) The YZH package is only available taped and reeled. The suffix “R” indicates a reel of 3000, the suffix “T” indicates a reel of 250.

ABSOLUTE MAXIMUM RATINGS

Over operating free–air temperature range, T_A = 25°C (unless otherwise noted)⁽¹⁾

		MIN	MAX
Supply voltage	VBAT	–0.3 V	6 V
Input Voltage, V _I	IN+, IN–	–0.3 V	VBAT + 0.3 V
Output continuous total power dissipation		See the Thermal Information Table	
Operating free-air temperature range, T _A		–40°C	85°C
Operating junction temperature range, T _J		–40°C	150°C
Storage temperature range, T _{STG}		–65°C	150°C
Minimum load impedance		6 Ω	
ESD Protection	HBM		2000 V
	CDM		500 V
	MM		100 V

- (1) Stresses beyond those listed under *absolute maximum ratings* may cause permanent damage to the device. These are stress ratings only, and functional operation of the device at these or any other conditions beyond those indicated under *recommended operating conditions* is not implied. Exposure to absolute–maximum–rated conditions for extended periods may affect device reliability.

THERMAL INFORMATION

THERMAL METRIC ⁽¹⁾		TPA2015D1	UNITS
		YZH	
		16 PINS	
θ_{JA}	Junction-to-ambient thermal resistance ⁽²⁾	75	°C/W
$\theta_{JC(top)}$	Junction-to-case(top) thermal resistance ⁽³⁾	22	
θ_{JB}	Junction-to-board thermal resistance ⁽⁴⁾	26	
ψ_{JT}	Junction-to-top characterization parameter ⁽⁵⁾	0.5	
ψ_{JB}	Junction-to-board characterization parameter ⁽⁶⁾	25	
$\theta_{JC(bottom)}$	Junction-to-case(bottom) thermal resistance ⁽⁷⁾	n/a	

- (1) For more information about traditional and new thermal metrics, see the *IC Package Thermal Metrics* application report, [SPRA953](#).
- (2) The junction-to-ambient thermal resistance under natural convection is obtained in a simulation on a JEDEC-standard, high-K board, as specified in JESD51-7, in an environment described in JESD51-2a.
- (3) The junction-to-case (top) thermal resistance is obtained by simulating a cold plate test on the package top. No specific JEDEC-standard test exists, but a close description can be found in the ANSI SEMI standard G30-88.
- (4) The junction-to-board thermal resistance is obtained by simulating in an environment with a ring cold plate fixture to control the PCB temperature, as described in JESD51-8.
- (5) The junction-to-top characterization parameter, ψ_{JT} , estimates the junction temperature of a device in a real system and is extracted from the simulation data for obtaining θ_{JA} , using a procedure described in JESD51-2a (sections 6 and 7).
- (6) The junction-to-board characterization parameter, ψ_{JB} , estimates the junction temperature of a device in a real system and is extracted from the simulation data for obtaining θ_{JA} , using a procedure described in JESD51-2a (sections 6 and 7).
- (7) The junction-to-case (bottom) thermal resistance is obtained by simulating a cold plate test on the exposed (power) pad. No specific JEDEC standard test exists, but a close description can be found in the ANSI SEMI standard G30-88.

RECOMMENDED OPERATING CONDITIONS

		MIN	MAX	UNIT
	Supply voltage, VBAT	2.5	5.2	V
V_{IH}	High-level input voltage, END, ENB	1.3		V
V_{IL}	Low-level input voltage, END, ENB		0.6	V
T_A	Operating free-air temperature	-40	85	°C
T_J	Operating junction temperature	-40	150	°C

ELECTRICAL CHARACTERISTICS

VBAT = 3.6 V, Gain = 6 dB, R_{AGC} = Float, T_A = 25°C, R_L = 8 Ω + 33 μ H (unless otherwise noted)

PARAMETER	TEST CONDITIONS	MIN	TYP	MAX	UNIT
VBAT supply voltage range	END = 0 V, ENB = VBAT	2.5		5.2	V
	END = VBAT, ENB = VBAT, AGC options 1, 2, and 3	2.5		5.2	
	END = VBAT, ENB = VBAT, AGC option 0	2.8		5.2	
Class-D supply voltage range	END = ENB = VBAT, boost converter active	5.2		5.8	V
	END = VBAT, ENB = 0 V	3.1		5.25	V
Power supply ripple rejection	VBAT = 2.5 V to 5.2 V, END = ENB = VBAT		85		dB
	VBAT = 2.5 V to 5.2 V, END = VBAT, ENB = 0 V (pass through mode)		75		
Operating quiescent current	END = 0 V, ENB = VBAT		0.5		mA
	END = ENB = VBAT		1.7	2.2	mA
Shutdown quiescent current	VBAT = 2.5 V to 5.2 V, END = ENB = GND		0.2	3	μ A
Gain control pin voltage	Gain = 6 dB (connect to GND)	0	0.25 \times VBAT		V
	Gain = 15.5 dB (float)	0.4 \times VBAT	0.6 \times VBAT		
	Gain = 20 dB (connect to VBAT)	0.75 \times VBAT			

ELECTRICAL CHARACTERISTICS (continued)

 VBAT = 3.6 V, Gain = 6 dB, R_{AGC} = Float, T_A = 25°C, R_L = 8 Ω + 33 μH (unless otherwise noted)

PARAMETER	TEST CONDITIONS	MIN	TYP	MAX	UNIT
AGC control pin voltage	AGC with no inflection point, R _{AGC} = Open	2			V
	AGC option 1 (inflection = 3.55 V), R _{AGC} = 39 kΩ (±5%)	1.36		1.75	
	AGC option 2 (inflection = 3.78 V), R _{AGC} = 27 kΩ (±5%)	0.94		1.2	
	AGC option 3 (inflection = 3.96 V), R _{AGC} = 18 kΩ (±5%)	0		0.825	
AGC control pin output current		37.6	40	42.4	μA
Input common-mode voltage range	IN+, IN–	0.6			V
Start-up time	Boost converter followed by Class-D amplifier		6	10	ms
	Boost converter only		1	4	
	Class-D amplifier only		5	6	

OPERATING CHARACTERISTICS

 VBAT = 3.6 V, T_A = 25°C, R_L = 8 Ω + 33 μH (unless otherwise noted)

PARAMETER	TEST CONDITIONS	MIN	TYP	MAX	UNIT	
BOOST CONVERTER						
	Boost converter output voltage range, P _{VOUT}	I _{BOOST} = 700 mA		5.2	5.8	V
I _L	Boost converter input current limit	Power supply current		1500		mA
	Boost converter start-up current limit			450		mA
η	Boost converter efficiency	END = 0 V, I _{PVOUT} = 100 mA constant		88%		
f _{BOOST}	Boost converter frequency			1.2		MHz
CLASS-D AMPLIFIER						
P _O	Output power	THD = 1%, VBAT = 2.5 V, f = 1 kHz		1200		mW
		THD = 1%, VBAT = 3 V, f = 1 kHz		1500		
		THD = 1%, VBAT = 3.6 V, f = 1 kHz		1700		
V _O	Output peak voltage	THD = 1%, VBAT = 3 V, f = 1 kHz, 6 dB crest factor sine burst, no clipping		5.2		V
A _V	Closed-loop voltage gain	GAIN < 0.25 × VBAT		6		dB
		0.4 × VBAT < GAIN < 0.6 × VBAT (or float)		15.5		
		GAIN > 0.75 × VBAT		20		
ΔA _V	Gain accuracy			–0.5	0.5	dB
V _{OOS}	Output offset voltage			10		mV
R _{IN}	Input impedance (per input pin)	A _V = 6 dB		27.8		kΩ
		A _V = 15.5 dB		14.9		
		A _V = 20 dB		10.1		
	Input impedance in shutdown (per input pin)	END = 0 V		88.4		kΩ
Z _O	Output impedance in shutdown	END = 0 V		2		kΩ
f _{CLASS-D}	Switching frequency		560	600	640	kHz
E _N	Noise output voltage	A-weighted, GAIN = 6 dB		24.8		μV _{RMS}
		A-weighted, GAIN = 15.5 dB		33.4		
		A-weighted, GAIN = 20 dB		42.4		
THD+N	Total harmonic distortion plus noise ⁽¹⁾	P _O = 100 mW, f = 1 kHz		0.06%		
		P _O = 500 mW, f = 1 kHz		0.07%		
AC PSRR	AC-Power supply ripple rejection (output referred)	200 mV _{PP} ripple, f = 217 Hz		75		dB
		200 mV _{PP} ripple, f = 4 kHz		70		

(1) A-weighted

OPERATING CHARACTERISTICS (continued)

V_{BAT} = 3.6 V, T_A = 25°C, R_L = 8 Ω + 33 μH (unless otherwise noted)

PARAMETER	TEST CONDITIONS	MIN	TYP	MAX	UNIT
Audio frequency passband ripple	f _{AUDIO} = 20 Hz, C _{IN} = 1 μF	-0.2	-0.1	0	dB
	f _{AUDIO} = 16 kHz, C _{IN} = 1 μF	-0.2	-0.1	0	
AUTOMATIC GAIN CONTROL					
AGC gain range		0		20	dB
AGC gain step size			0.5		dB
AGC attack time (gain decrease)			0.026		ms/dB
AGC release time (gain increase)			1600		ms/dB
Limiter threshold voltage	V _{BAT} > inflection point		6.15		V
V _{BAT} vs. Limiter slope	V _{BAT} < inflection point		3		V/V
AGC inflection point	AGC option 1, R _{AGC} = 39 kΩ (±5%)		3.55		V
	AGC option 2, R _{AGC} = 27 kΩ (±5%)		3.78		
	AGC option 3, R _{AGC} = 18 kΩ (±5%)		3.96		

TEST SET-UP FOR GRAPHS

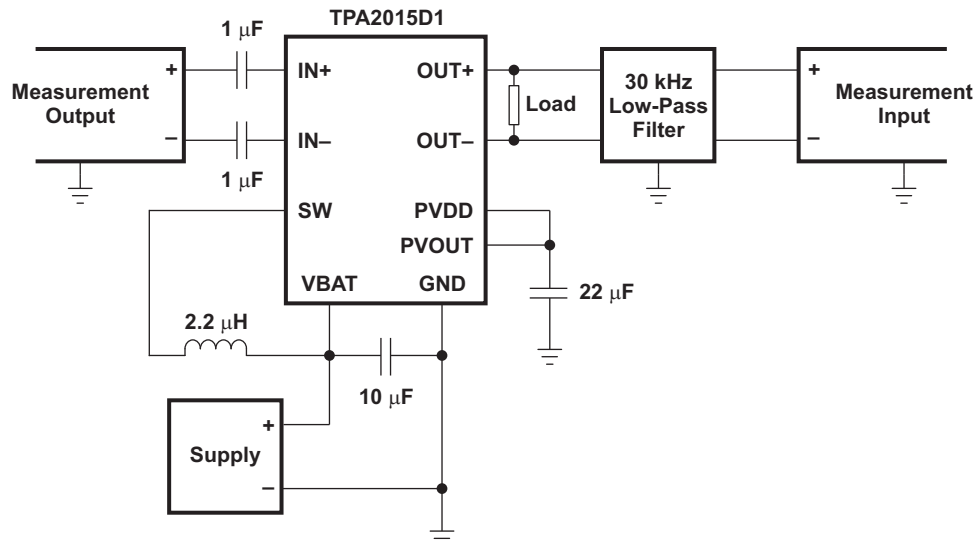

- (1) The 1 μF input capacitors (C_i) were shorted for input common-mode voltage measurements.
- (2) A 33 μH inductor was placed in series with the load resistor to emulate a small speaker for efficiency measurements.
- (3) The 30 kHz low-pass filter is required even if the analyzer has an internal low-pass filter. An R-C low pass filter (100 Ω, 47 nF) is used on each output for the data sheet graphs.

TYPICAL CHARACTERISTICS

$V_{BAT} = 3.6\text{ V}$, Gain = 6 dB, $C_I = 1\ \mu\text{F}$, $C_{BOOST} = 22\ \mu\text{F}$, $L_{BOOST} = 2.2\ \mu\text{H}$, AGC = Float, ENB = END = V_{BAT} , and Load = $8\ \Omega + 33\ \mu\text{H}$ unless otherwise specified.

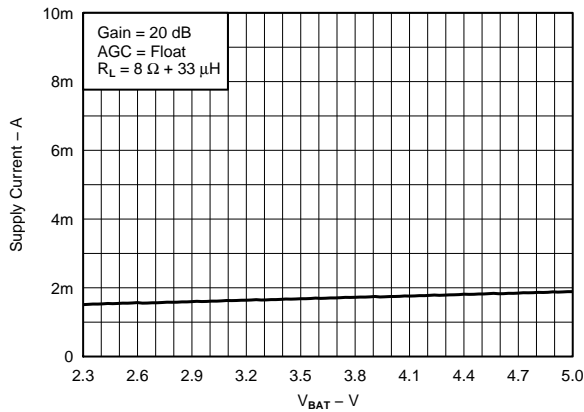

Figure 1. QUIESCENT SUPPLY CURRENT vs SUPPLY VOLTAGE

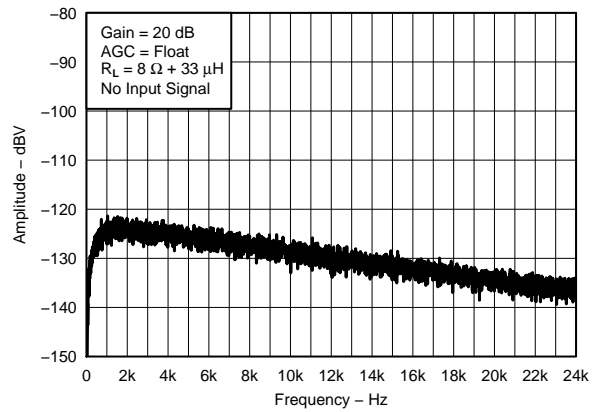

Figure 2. A-WEIGHTED OUTPUT NOISE vs FREQUENCY

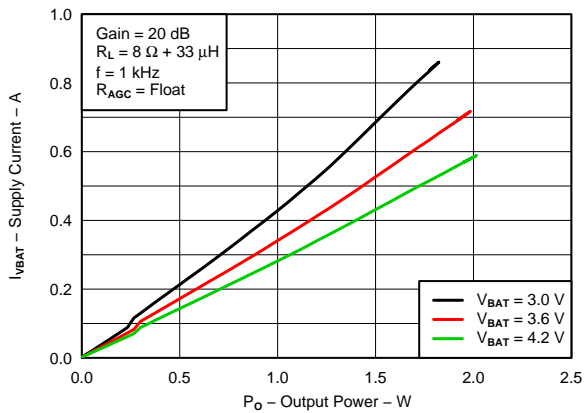

Figure 3. SUPPLY CURRENT vs OUTPUT POWER

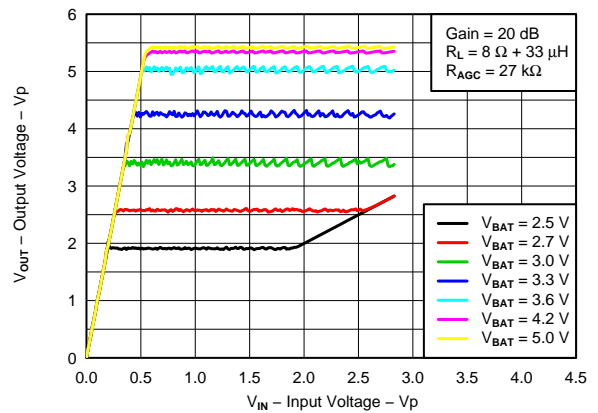

Figure 4. PEAK OUTPUT VOLTAGE vs PEAK INPUT VOLTAGE

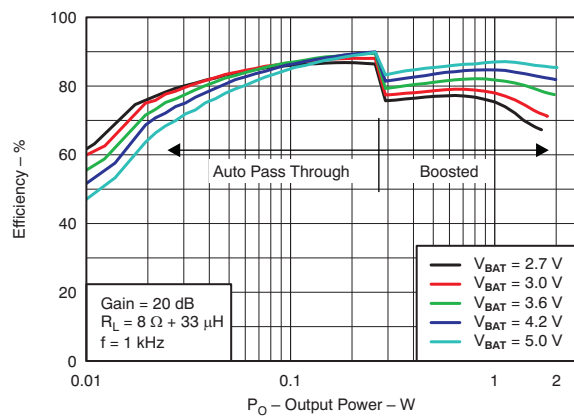

Figure 5. TOTAL EFFICIENCY vs OUTPUT POWER

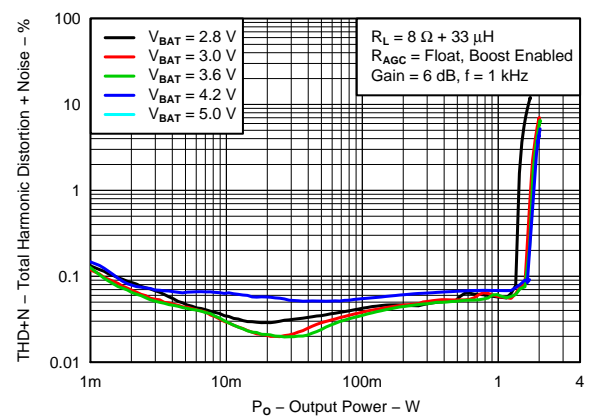

Figure 6. TOTAL HARMONIC DISTORTION + NOISE vs OUTPUT POWER

TYPICAL CHARACTERISTICS (continued)

$V_{BAT} = 3.6\text{ V}$, Gain = 6 dB, $C_I = 1\ \mu\text{F}$, $C_{BOOST} = 22\ \mu\text{F}$, $L_{BOOST} = 2.2\ \mu\text{H}$, AGC = Float, ENB = END = V_{BAT} , and Load = $8\ \Omega + 33\ \mu\text{H}$ unless otherwise specified.

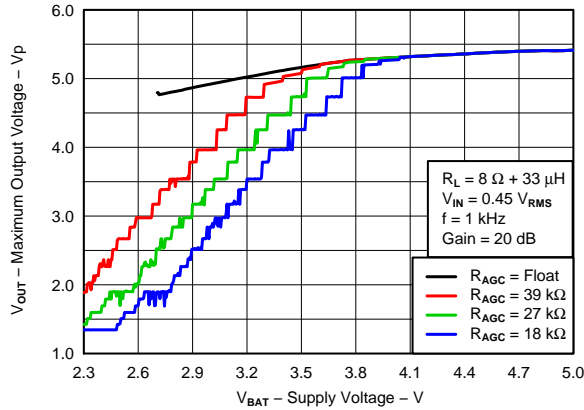

Figure 7. MAXIMUM OUTPUT VOLTAGE vs SUPPLY VOLTAGE

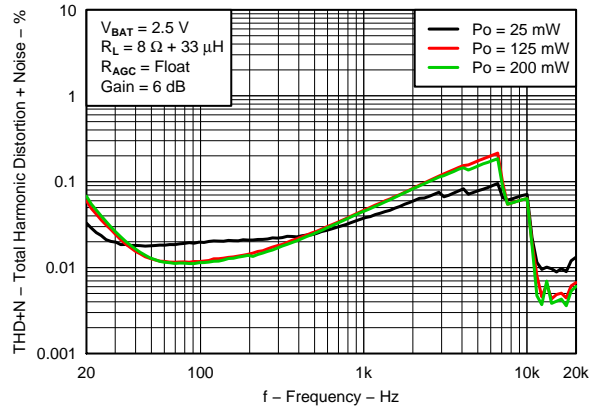

Figure 8. TOTAL HARMONIC DISTORTION + NOISE vs FREQUENCY

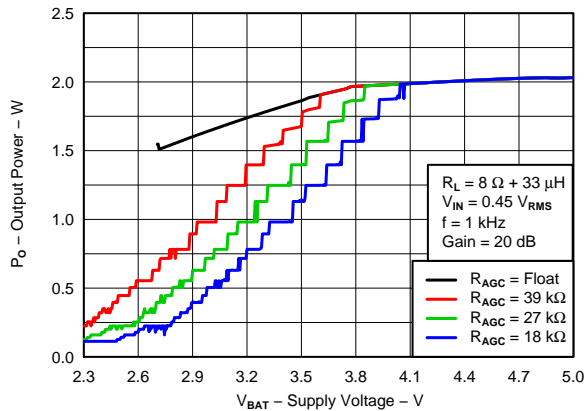

Figure 9. OUTPUT POWER vs SUPPLY VOLTAGE

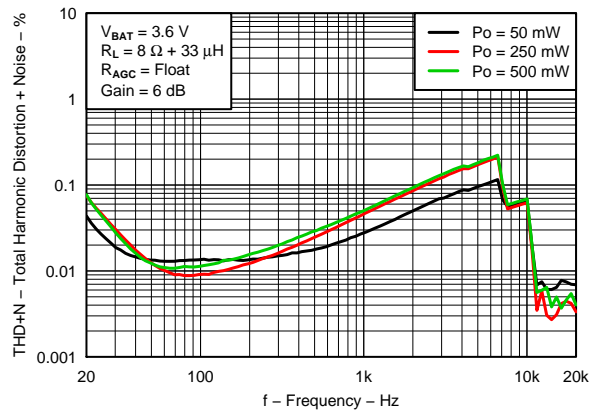

Figure 10. TOTAL HARMONIC DISTORTION + NOISE vs FREQUENCY

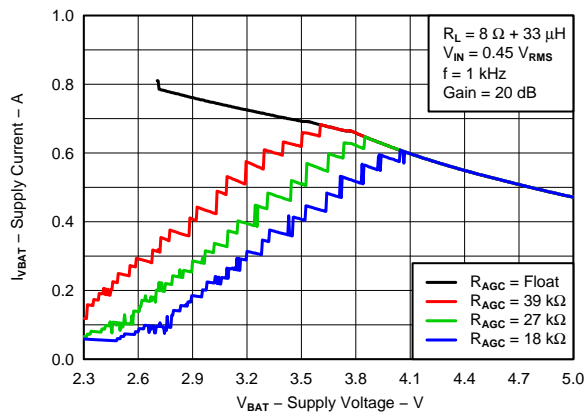

Figure 11. SUPPLY CURRENT vs SUPPLY VOLTAGE

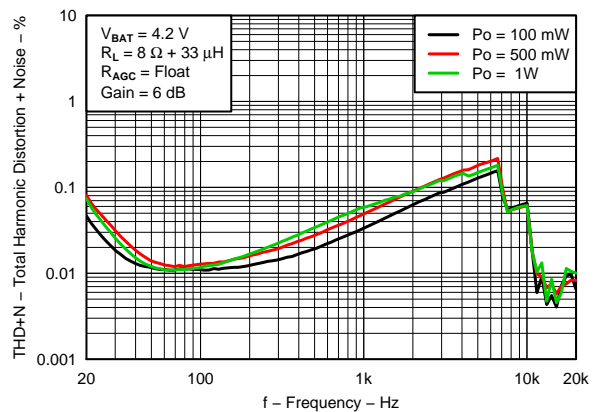

Figure 12. TOTAL HARMONIC DISTORTION + NOISE vs FREQUENCY

TYPICAL CHARACTERISTICS (continued)

$V_{BAT} = 3.6\text{ V}$, Gain = 6 dB, $C_1 = 1\ \mu\text{F}$, $C_{BOOST} = 22\ \mu\text{F}$, $L_{BOOST} = 2.2\ \mu\text{H}$, AGC = Float, ENB = END = V_{BAT} , and Load = $8\ \Omega + 33\ \mu\text{H}$ unless otherwise specified.

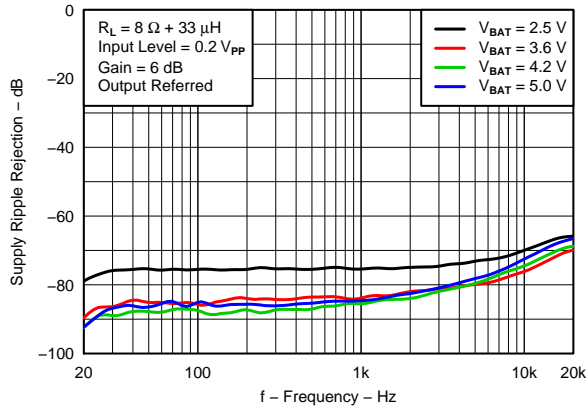

Figure 13. SUPPLY RIPPLE REJECTION vs FREQUENCY

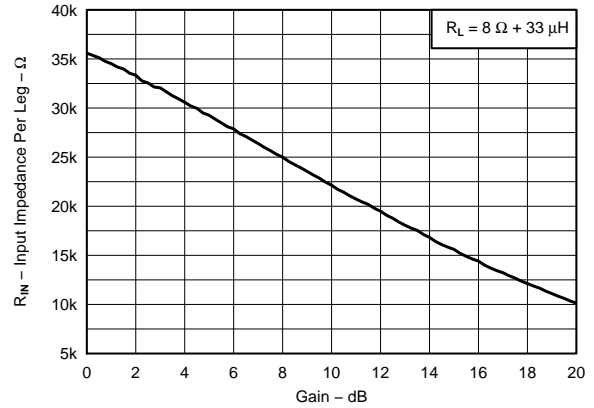

Figure 14. INPUT IMPEDANCE (PER INPUT) vs GAIN

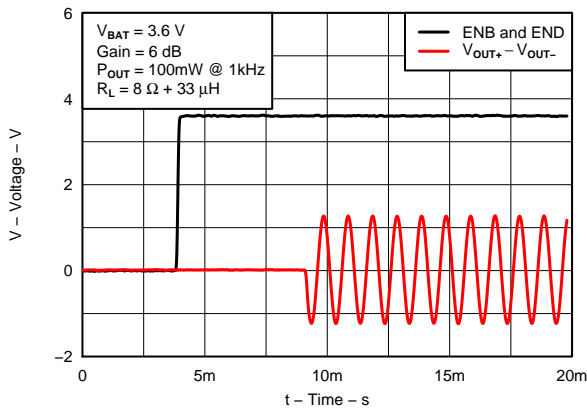

Figure 15. STARTUP TIMING

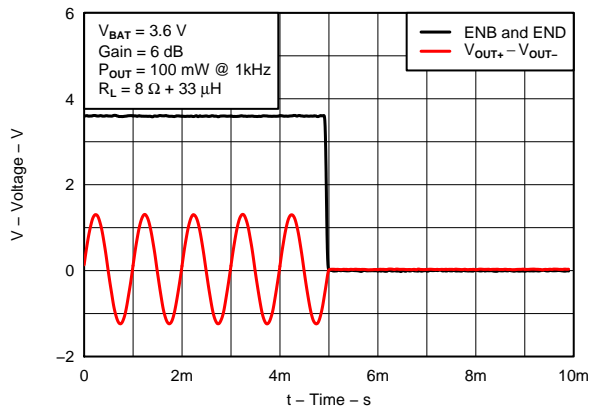

Figure 16. SHUTDOWN TIMING

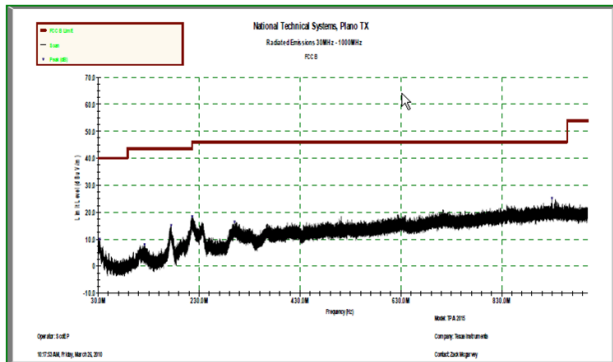

Figure 17. EMC PERFORMANCE
 $P_O = 50\text{ mW}$ with 2 INCH SPEAKER CABLE

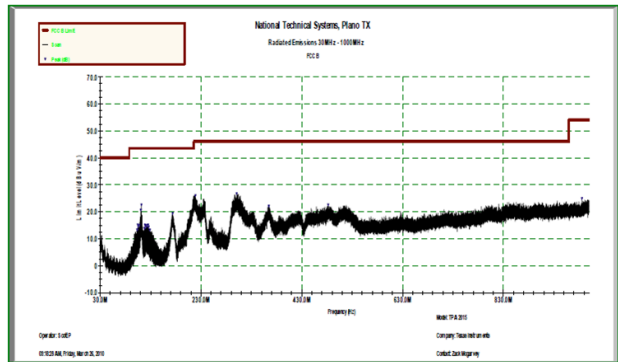

Figure 18. EMC PERFORMANCE
 $P_O = 750\text{ mW}$ with 2 INCH SPEAKER CABLE

APPLICATION INFORMATION

APPLICATION CIRCUIT

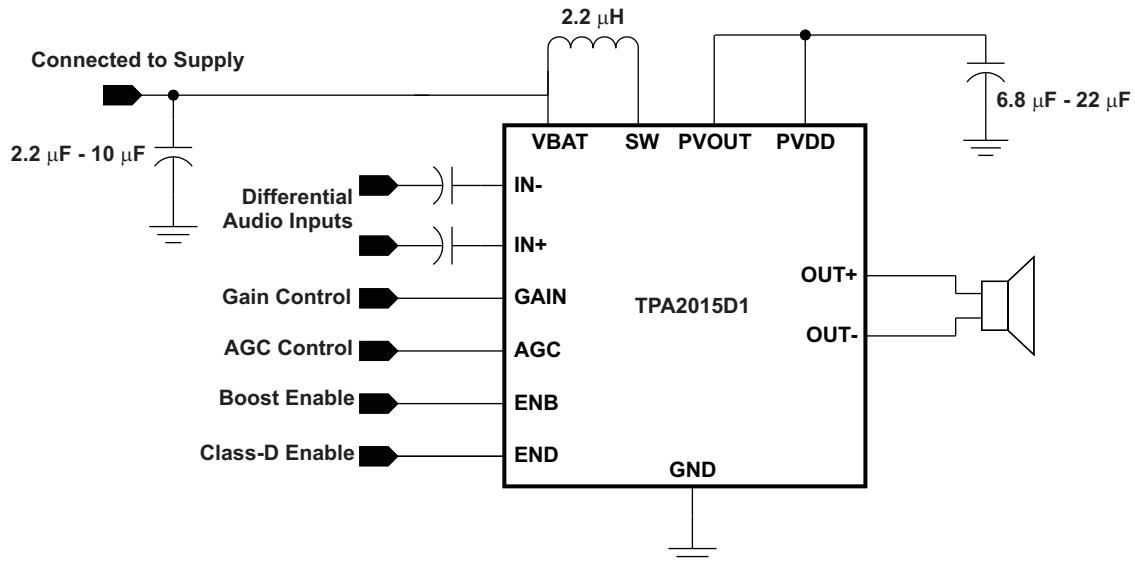

Figure 19. Typical Application Schematic with Differential Input Signals

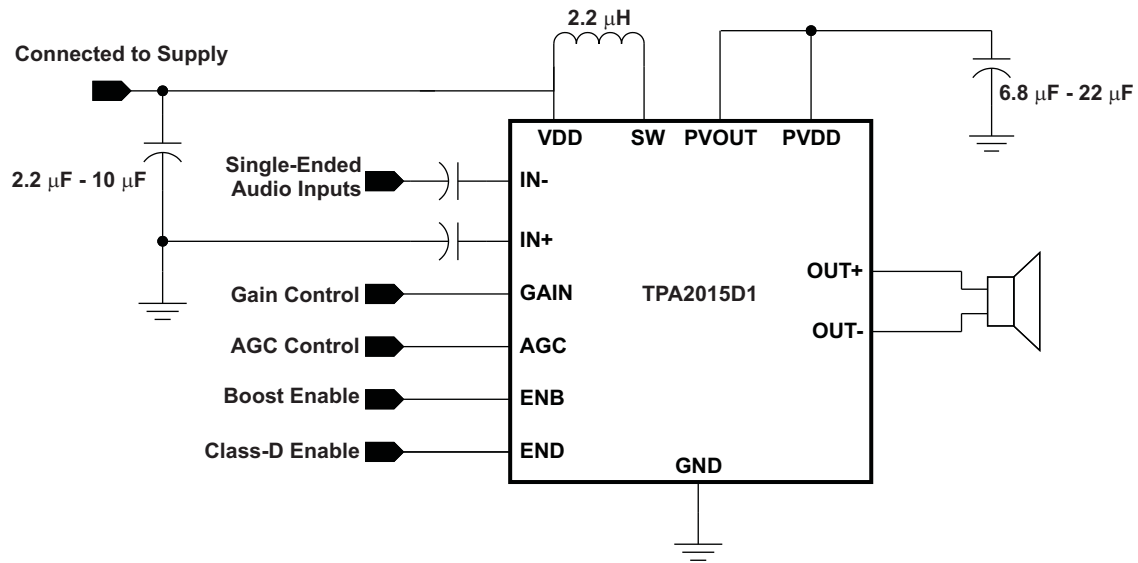

Figure 20. Typical Application Schematic with Single-Ended Input Signals

GLOSSARY

The application section uses the following terms:

Limiter level	The maximum output voltage allowed before amplifier gain is automatically reduced.
SpeakerGuard™	TI's trademark name for the automatic gain control technology. It protects speakers by limiting maximum output power.
Inflection point	The battery voltage threshold for reducing the limiter level. If the battery voltage drops below the inflection point, the limiter level automatically reduces. Although it lowers the maximum output power, it prevents high battery currents at end-of-charge low battery voltages.
Battery track	The name for the continuous limiter level reduction at battery voltages below the inflection point.
AGC	Automatic gain control.
VBAT	The battery supply voltage to the TPA2015D1. The VBAT pin is the input to the boost converter.
Fixed-gain	The nominal audio gain as set by the GAIN pin. If the audio output voltage remains below the limiter level, the amplifier gain will return to the fixed-gain.
Attack time	The rate of AGC gain decrease. The attack time is constant at 0.026 ms/dB.
Release time	The rate of AGC gain increase. The release time is constant at 1600 ms/dB.

SPEAKERGUARD™ THEORY OF OPERATION

SpeakerGuard™ protects speakers, improves loudness, and limits peak supply current. If the output audio signal exceeds the limiter level, then SpeakerGuard™ decreases amplifier gain. The rate of gain decrease, the attack time, is fixed at 0.026 ms/dB. SpeakerGuard™ increases the gain once the output audio signal is below the limiter level. The rate of gain increase, the release time, is fixed at 1600 ms/dB. [Figure 21](#) shows this relationship.

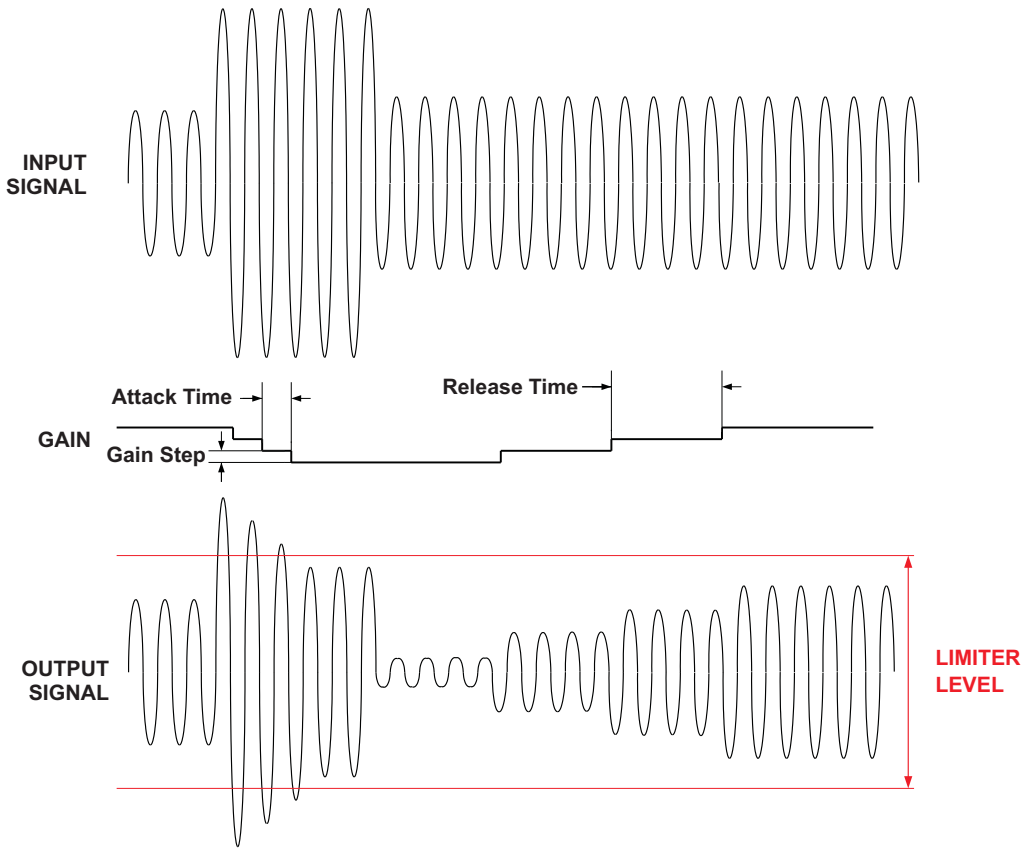

Figure 21. SpeakerGuard Attack and Release Times

BATTERY TRACKING SPEAKERGUARD™

The TPA2015D1 monitors the battery voltage and the audio signal, automatically decreasing gain when battery voltage is low and audio output power is high. It finds the optimal gain to maximize loudness and minimize battery current, providing louder audio and preventing early shutdown at end-of-charge battery voltages. SpeakerGuard decreases amplifier gain when the audio signal exceeds the limiter level. The limiter level automatically decreases when the supply voltage (VBAT) is below the inflection point. Figure 22 shows a plot of the limiter level as a function of the supply voltage.

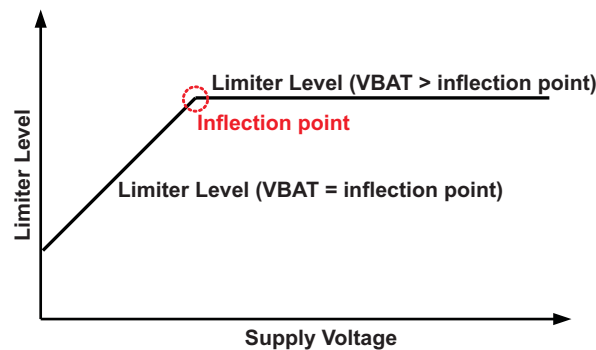

Figure 22. Limiter Level vs Supply Voltage

The limiter level decreases within 60 μ s of the supply voltage dropping below the inflection point. Although this is slightly slower than the 26 μ s/dB SpeakerGuard attack time, the difference is audibly imperceptible.

Connect a resistor between the AGC pin and ground to set the inflection point, as shown in [Table 1](#). Leave the AGC pin floating to disable the inflection point, keeping the limiter level constant over all supply voltages.

The maximum limiter level is fixed, as is the slope of the limiter level versus supply voltage. If different values for maximum limiter level and slope are required, contact your local Texas Instruments representative.

Table 1. AGC Function Table

Function	Resistor on AGC pin	Inflection Point
Constant limiter level; battery track OFF	Floating or connected to VBAT	disabled
AGC battery track option 1	39 kΩ	3.55 V
AGC battery track option 2	27 kΩ	3.78 V
AGC battery track option 3	18 kΩ	3.96 V

The audio signal is not affected by the SpeakerGuard™ function unless the peak audio output voltage exceeds the limiter level. [Figure 23](#) shows the relationship between the audio signal, the limiter level, the supply voltage, and the supply current.

When VBAT is greater than the inflection point, the limiter level allows the output signal to slightly clip to roughly 6% THD at 2 W into 8 Ω. This is an acceptable peak distortion level for most small-sized portable speakers, while ensuring maximum loudness from the speaker.

Battery Tracking SpeakerGuard™ Example

Phase 1 Battery discharging normally; supply voltage is above inflection point; audio output remains below limiter level.

The limiter level remains constant because the supply voltage is greater than the inflection point. Amplifier gain is constant at fixed-gain as set by the GAIN pin. The audio output remains at a constant loudness. The boost converter allows the audio output to swing above the battery supply voltage. Battery supply current increases as supply voltage decreases.

Phase 2 Battery continues to discharge normally; supply voltage decreases below inflection point; limiter level decreases below audio output.

The limiter level decreases as the battery supply voltage continues to decrease. SpeakerGuard™ lowers amplifier gain, reducing the audio output below the new limiter level. The supply current decreases due to reduced output power.

Phase 3 Battery supply voltage is constant; audio output remains below limiter level.

The audio output, limiter level, and supply current remain constant as well.

Phase 4 Phone plugged in and battery re-charges; supply voltage increases.

The limiter level increases as the supply voltage increases. SpeakerGuard™ increases amplifier gain slowly, increasing audio output. Because the TPA2015D1 supply current is proportional to the PVOOUT-to-VBAT ratio, the supply current decreases as battery supply voltage increases.

Phase 5 Battery supply voltage is constant; audio output is below limiter level.

SpeakerGuard™ continues to increase amplifier gain to the fixed-gain as set by the GAIN pin. The audio output signal increases (slowly due to release time) to original value.

Phase 6 Battery supply voltage is constant; audio output remains below limiter level.

Amplifier gain equal to fixed-gain as set by the GAIN pin. Audio output signal does not change. Supply current remains constant.

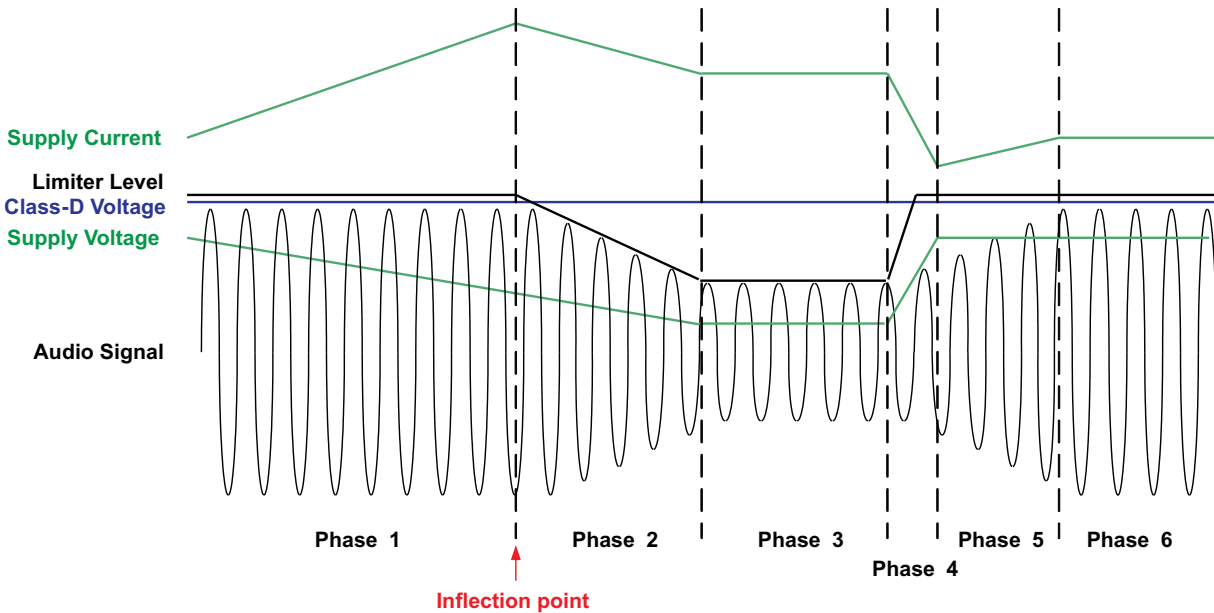

Figure 23. Relationship Between Supply Voltage, Current, Limiter Level, and Output Audio Signal

SpeakerGuard with Varying Input Levels

SpeakerGuard protects speakers by decreasing gain during large output transients. Figure 24 shows the maximum output voltage at different input voltage levels. The load is 8 Ω and the gain is 15.5 dB.

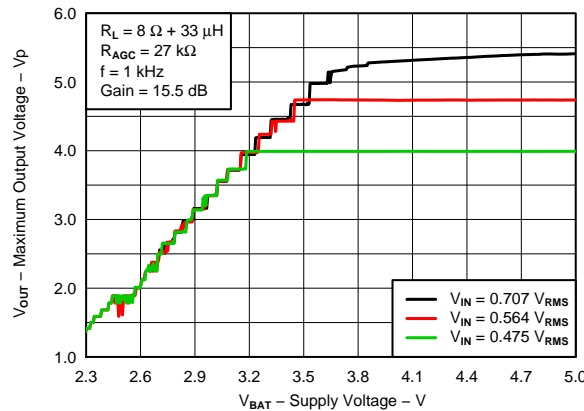

Figure 24. MAXIMUM OUTPUT VOLTAGE vs SUPPLY VOLTAGE

A 0.707 V_{RMS} sine-wave input signal forces the output voltage to 4.242 V_{RMS}, or 6.0 V_{PEAK}. Above 3.9 V supply, the boost converter voltage sags due to high output current, resulting in a peak Class-D output voltage of about 5.4 V. As the supply voltage decreases below 3.9 V, the limiter level decreases. This causes the gain to decrease, and the peak Class-D output voltage lowers.

With a 0.564 V_{RMS} input signal, the peak Class-D output voltage is 4.78 V. When the supply voltage is above 3.45 V, the output voltage remains below the limiter level, and the gain stays at 15.5 dB. Once the supply drops below 3.45 V, the limiter level decreases below 4.78 V, and SpeakerGuard decreases the gain.

The same rationale applies to the 0.475 V_{RMS} input signal. Although the supply voltage may be below the inflection point, audio gain does not decrease until the Class-D output voltage is above the limiter level.

SPEAKER LOAD LIMITATION

Speakers are non-linear loads with varying impedance (magnitude and phase) over the audio frequency. A portion of speaker load current can flow back into the boost converter output via the Class-D output H-bridge high-side device. This is dependent on the speaker's phase change over frequency, and the audio signal amplitude and frequency content.

Most portable speakers have limited phase change at the resonant frequency, typically no more than 40 or 50 degrees. To avoid excess flow-back current, use speakers with limited phase change. Otherwise, flow-back current could exceed the 10 mA rating of the boost converter voltage clamp and drive the PVOUT voltage above the absolute maximum recommended operational voltage.

Confirm proper operation by connecting the speaker to the TPA2015D1 and driving it at maximum output swing. Observe the PVOUT voltage with an oscilloscope. In the unlikely event the PVOUT voltage exceeds 6.5 V, add a 6.8 V Zener diode between PVOUT and ground to ensure the TPA2015D1 operates properly.

The amplifier has thermal overload protection and deactivates if the die temperature exceeds 150°C. It automatically reactivates once die temperature returns below 150°C. Built-in output over-current protection deactivates the amplifier if the speaker load becomes short-circuited. The amplifier automatically restarts within 200 ms after the over-current event. Although the TPA2015D1 Class-D output can withstand a short between OUT+ and OUT-, do not connect either output directly to GND, PVDD, or VBAT as this could damage the device.

WARNING

Do not connect OUT+ or OUT- directly to GND, PVDD, or VBAT as this could damage the Class-D output stage.

FULLY DIFFERENTIAL CLASS-D AMPLIFIER

The TPA2015D1 uses a fully differential amplifier with differential inputs and outputs. The differential output voltage equals the differential input multiplied by the amplifier gain. The TPA2015D1 can also be used with a single-ended input. However, using differential input signals when in a noisy environment, like a wireless handset, ensures maximum system noise rejection.

Advantages of Fully Differential Amplifiers

- Mid-supply bypass capacitor, C_{BYPASS} , not required:
 - The fully differential amplifier does not require a mid-supply bypass capacitor. Any shift in the mid-supply affects both positive and negative channels equally and cancels at the differential output.
- Improved RF-immunity:
 - GSM handsets save power by turning on and shutting off the RF transmitter at a rate of 217 Hz. This 217 Hz burst often couples to audio amplifier input and output traces causing frame-rate noise. Fully differential amplifiers cancel frame-rate noise better than non-differential amplifiers.
- Input-coupling capacitors not required, but recommended:
 - The fully differential amplifier allows the inputs to be biased at voltages other than mid-supply ($PVDD/2$). The TPA2015D1 inputs can be biased anywhere within the common mode input voltage range, as listed in the [OPERATING CHARACTERISTICS](#) table. If the inputs are biased outside of that range, then input-coupling capacitors are required.
 - Note that without input coupling capacitors, any dc offset from the audio source will be modulated by the AGC. This could cause artifacts in the audio output signal. Perform listening tests to determine if direct input coupling is acceptable.

The TPA2015D1 has 3 selectable fixed-gains: 6 dB, 15.5 dB, and 20 dB. Connect the GAIN pin as shown in [Table 2](#).

Table 2. Amplifier Fixed-Gain

Connect GAIN Pin to	Amplifier Gain
GND	6 dB
No Connection (Floating)	15.5 dB
VBAT	20 dB

Improved Class-D Efficiency

The TPA2015D1 output stage uses a modulation technique that modulates the PWM output only on one side of the differential output, leaving the other side held at ground. Although the differential output voltage is undistorted, each output appears as a half-wave rectified signal.

This technique reduces output switching losses and improves overall amplifier efficiency. [Figure 25](#) shows how OUT+, OUT-, and the differential output voltages appear on an oscilloscope.

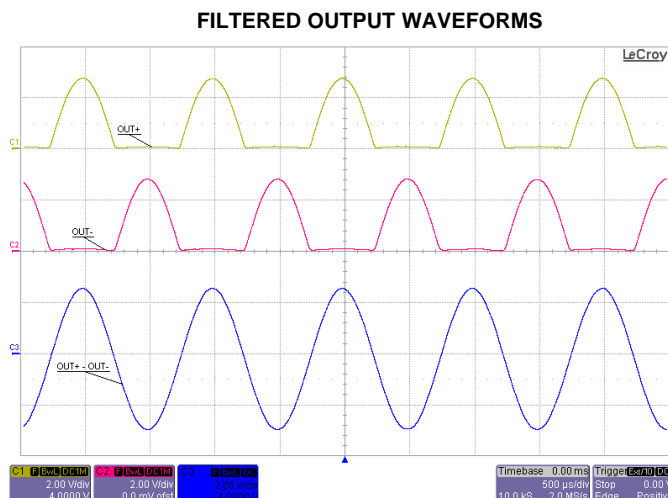

Figure 25.

ADAPTIVE BOOST CONVERTER

The TPA2015D1 consists of an adaptive boost converter and a Class-D amplifier. The boost converter takes the supply voltage, VBAT, and increases it to a higher output voltage, PVOOUT. PVOOUT drives the supply voltage of the Class-D amplifier, PVDD. This improves loudness over non-boosted solutions.

The boost converter is adaptive and activates automatically depending on the output audio signal amplitude. When the peak output audio signal exceeds a preset voltage threshold, the boost converter is enabled, and the voltage at PVOOUT is 5.5 V. When the audio output voltage is lower than the threshold voltage, the boost deactivates automatically. The boost activation threshold voltage is not user programmable. It is optimized to prevent clipping while maximizing system efficiency.

The boost converter can be forcibly deactivated by setting the ENB pin to logic-low. When the boost is deactivated, PVOOUT is equal to the supply voltage (VBAT) minus the $I \times R$ drop across the inductor and boost converter pass transistor.

A timer prevents the input signal from modulating the PVOOUT voltage within the audio frequency range, eliminating the potential for audible artifacts on the Class-D output.

Figure 26 shows how the adaptive boost modulates with a typical audio signal. By automatically deactivating the boost converter and passing VBAT to PVOOUT, the TPA2015D1 efficiency is improved at low output power.

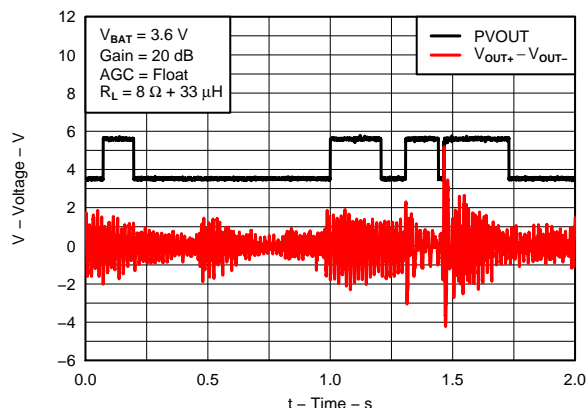

Figure 26. ADAPTIVE BOOST CONVERTER with TYPICAL MUSIC PLAYBACK

The primary external components for the boost converter are the inductor and the boost capacitor. The inductor stores current, and the boost capacitor stores charge. As the Class-D amplifier depletes the charge in the boost capacitor, the boost inductor replenishes charge with its stored current. The cycle of charge and discharge occurs frequently enough to keep PVOOUT within its minimum and maximum voltage specification.

The boost converter design is optimized for driving the integrated Class-D amplifier only. It lacks protection circuitry recommended for driving loads other than the integrated Class-D amplifier.

Boost Converter Overvoltage Protection

The TPA2015D1 internal boost converter operates in a discontinuous mode to improve the efficiency at light loads. The boost converter has overvoltage protection that disables the boost converter if the output voltage exceeds 5.8 V. If current is forced into the PVOOUT terminal, the voltage clamp will sink up to 10 mA. If more than 10 mA is forced into PVOOUT, then the PVOOUT voltage will increase. Refer to the [SPEAKER LOAD LIMITATION](#) section for details.

Boost Converter Component Section

Boost Terms

The following is a list of terms and definitions used in the boost equations found later in this document.

C	Minimum boost capacitance required for a given ripple voltage on PVOOUT.
L	Boost inductor.
f_{BOOST}	Switching frequency of the boost converter.
I_{PVDD}	Current pulled by the Class-D amplifier from the boost converter.
I_L	Average current through the boost inductor.
PVDD (PVOOUT)	Supply voltage for the Class-D amplifier. (Voltage generated by the boost converter output.)
VBAT	Supply voltage to the IC.
ΔI_L	Ripple current through the inductor.
ΔV	Ripple voltage on PVOOUT.

Boost Converter Inductor Selection

Working inductance decreases as inductor current and temperature increases. If the drop in working inductance is severe enough, it may cause the boost converter to become unstable, or cause the TPA2015D1 to reach its current limit at a lower output voltage than expected. Inductor vendors specify currents at which inductor values decrease by a specific percentage. This can vary by 10% to 35%. Inductance is also affected by dc current and temperature.

Inductor Equations

Inductor current rating is determined by the requirements of the load. The inductance is determined by two factors: the minimum value required for stability and the maximum ripple current permitted in the application.

Use [Equation 1](#) to determine the required current rating. [Equation 1](#) shows the approximate relationship between the average inductor current, I_L , to the load current, load voltage, and input voltage (I_{PVDD} , PVDD, and VBAT, respectively). Insert I_{PVDD} , PVDD, and VBAT into Equation 1 and solve for I_L . The inductor must maintain at least 90% of its initial inductance value at this current.

$$I_L = I_{\text{PVDD}} \times \left(\frac{\text{PVDD}}{\text{VBAT} \times 0.8} \right) \quad (1)$$

WARNING

Use a minimum working inductance of 1.3 μH . Lower values may damage the inductor.

Ripple current, ΔI_L , is peak-to-peak variation in inductor current. Smaller ripple current reduces core losses in the inductor and reduces the potential for EMI. Use [Equation 2](#) to determine the value of the inductor, L. [Equation 2](#) shows the relationship between inductance L, VBAT, PVDD, the switching frequency, f_{BOOST} , and ΔI_L . Insert the maximum acceptable ripple current into [Equation 2](#) and solve for L.

$$L = \frac{V_{\text{BAT}} \times (P_{\text{VDD}} - V_{\text{BAT}})}{\Delta I_L \times f_{\text{BOOST}} \times P_{\text{VDD}}} \quad (2)$$

ΔI_L is inversely proportional to L. Minimize ΔI_L as much as is necessary for a specific application. Increase the inductance to reduce the ripple current. Do not use greater than 4.7 μH , as this prevents the boost converter from responding to fast output current changes properly. If using above 3.3 μH , then use at least 10 μF capacitance on PVOOUT to ensure boost converter stability.

The typical inductor value range for the TPA2015D1 is 2.2 μH to 3.3 μH . Select an inductor with less than 0.5 Ω dc resistance, DCR. Higher DCR reduces total efficiency due to an increase in voltage drop across the inductor.

Table 3. Sample Inductors

L (μH)	SUPPLIER	COMPONENT CODE	SIZE (LxWxH mm)	DCR TYP (m Ω)	I _{SAT} MAX (A)	C RANGE
2.2	Chilisin Electronics Corp.	CLCN252012T-2R2M-N	2.5 x 2.0 x 1.2	105	1.2	4.7 – 22 μF / 16 V 6.8 – 22 μF / 10 V
2.2	Toko	1239AS-H-2R2N=P2	2.5 x 2.0 x 1.2	96	2.3	
2.2	Coilcraft	XFL4020-222MEC	4.0 x 4.0 x 2.15	22	3.5	
3.3	Toko	1239AS-H-3R3N=P2	2.5 x 2.0 x 1.2	160	2.0	10 – 22 μF / 10 V
3.3	Coilcraft	XFL4020-332MEC	4.0 x 4.0 x 2.15	35	2.8	

Boost Converter Capacitor Selection

The value of the boost capacitor is determined by the minimum value of working capacitance required for stability and the maximum voltage ripple allowed on PVDD in the application. Working capacitance refers to the available capacitance after derating the capacitor value for DC bias, temperature, and aging.

Do not use any component with a working capacitance less than 4.7 μF . This corresponds to a 4.7 μF / 16 V capacitor, or a 6.8 μF / 10 V capacitor. Do not use above 22 μF capacitance as it will reduce the boost converter response time to large output current transients.

[Equation 3](#) shows the relationship between the boost capacitance, C, to load current, load voltage, ripple voltage, input voltage, and switching frequency (I_{PVDD} , PVDD, ΔV , VBAT, and f_{BOOST} respectively).

Insert the maximum allowed ripple voltage into [Equation 3](#) and solve for C. The 1.5 multiplier accounts for capacitance loss due to applied dc voltage and temperature for X5R and X7R ceramic capacitors.

$$C = 1.5 \times \frac{I_{\text{PVDD}} \times (P_{\text{VDD}} - V_{\text{BAT}})}{\Delta V \times f_{\text{BOOST}} \times P_{\text{VDD}}} \quad (3)$$

COMPONENTS LOCATION AND SELECTION

Decoupling Capacitors

The TPA2015D1 is a high-performance Class-D audio amplifier that requires adequate power supply decoupling. Adequate power supply decoupling to ensure that the efficiency is high and total harmonic distortion (THD) is low.

Place a low equivalent-series-resistance (ESR) ceramic capacitor, typically 0.1 μF , within 2 mm of the VBAT ball. This choice of capacitor and placement helps with higher frequency transients, spikes, or digital hash on the line. Additionally, placing this decoupling capacitor close to the TPA2015D1 is important, as any parasitic resistance or inductance between the device and the capacitor causes efficiency loss. In addition to the 0.1 μF ceramic capacitor, place a 2.2 μF to 10 μF capacitor on the VBAT supply trace. This larger capacitor acts as a charge reservoir, providing energy faster than the board supply, thus helping to prevent any droop in the supply voltage.

Input Capacitors

Input audio DC decoupling capacitors are recommended. The input audio DC decoupling capacitors prevent the AGC from changing the gain due to audio DAC output offset. The input capacitors and TPA2015D1 input impedance form a high-pass filter with the corner frequency, f_c , determined in [Equation 4](#).

Any mismatch in capacitance between the two inputs will cause a mismatch in the corner frequencies. Severe mismatch may also cause turn-on pop noise. Choose capacitors with a tolerance of $\pm 10\%$ or better.

$$f_c = \frac{1}{(2 \times \pi \times R_i C_i)} \quad (4)$$

EFFICIENCY AND THERMAL INFORMATION

It is important to operate the TPA2015D1 at temperatures lower than its maximum operating temperature. The maximum ambient temperature depends on the heat-sinking ability of the PCB system. The derating factor for the package is shown in the dissipation rating table. Converting this to θ_{JA} for the WCSP package:

$$\theta_{JA} = \frac{1}{\text{Derating Factor}} = \frac{1}{0.0065} = 153^\circ\text{C/W} \quad (5)$$

Given θ_{JA} of 153 $^\circ\text{C/W}$, the maximum allowable junction temperature of 150 $^\circ\text{C}$, and the internal dissipation of 0.34 W for 1.7 W, 8 Ω load, 3.6 V supply, the maximum ambient temperature is calculated as:

$$\theta_{JA} \text{ MAX} = T_{J} \text{ MAX} = \theta_{JA} P_{D\text{max}} = 150 - 153(0.34) = 97.98^\circ\text{C} \quad (6)$$

[Equation 6](#) shows that the calculated maximum ambient temperature is 98 $^\circ\text{C}$ at maximum power dissipation with a 3.6 V supply and 8 Ω load. The TPA2015D3 is designed with thermal protection that turns the device off when the junction temperature surpasses 150 $^\circ\text{C}$ to prevent damage to the IC.

OPERATION WITH DACS AND CODECS

Large ripple voltages can be present at the output of $\Delta\Sigma$ DACs and CODECs, just above the audio frequency (e.g: 80 kHz with a 300 mV_{PP}). This out-of-band noise is due to the noise shaping of the delta-sigma modulator in the DAC.

Some Class-D amplifiers have higher output noise when used in combination with these DACs and CODECs. This is because out-of-band noise from the CODEC/DAC mixes with the Class-D switching frequencies in the audio amplifier input stage.

The TPA2015D1 has a built-in low-pass filter that reduces the out-of-band noise and RF noise, filtering out-of-band frequencies that could degrade in-band noise performance. This built-in filter also prevents AGC errors due to out-of-band noise. The TPA2015D1 AGC calculates gain based on input signal amplitude only.

If driving the TPA2015D1 input with 4th-order or higher $\Delta\Sigma$ DACs or CODECs, add an R-C low pass filter at each of the audio inputs (IN+ and IN-) of the TPA2015D1 to ensure best performance. The recommended resistor value is 100 Ω and the capacitor value of 47 nF.

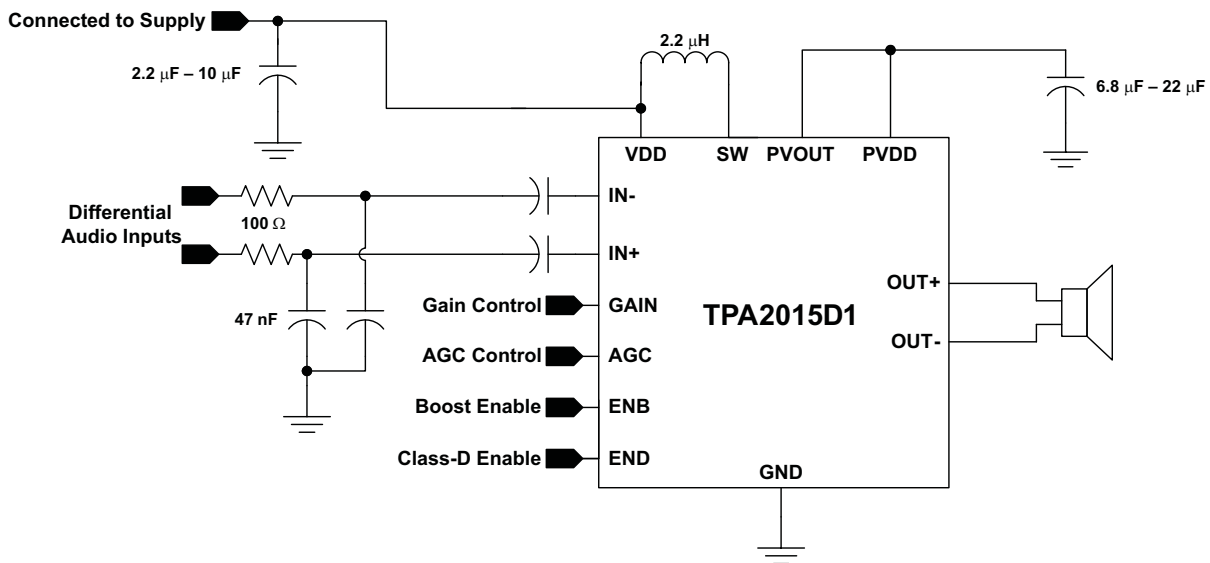

Figure 27. Reducing Out-of-Band DAC Noise with External Input Filter

FILTER FREE OPERATION AND FERRITE BEAD FILTERS

The TPA2015D1 is designed to minimize RF emissions. For more information about RF emissions and filtering requirements, See [SLOA145](#) for further information.

PACKAGE DIMENSIONS

The TPA2015D1 uses a 16-ball, 0.5 mm pitch WCSP package. The die length (D) and width (E) correspond to the package mechanical drawing at the end of the datasheet.

Table 4. Package Dimensions

Dimension	D	E
Max	1984 μm	1984 μm
Typ	1954 μm	1954 μm
Min	1924 μm	1924 μm

BOARD LAYOUT

In making the pad size for the WCSP balls, it is recommended that the layout use nonsolder mask defined (NSMD) land.

With this method, the solder mask opening is made larger than the desired land area, and the opening size is defined by the copper pad width. [Figure 28](#) and [Table 5](#) show the appropriate diameters for a WCSP layout.

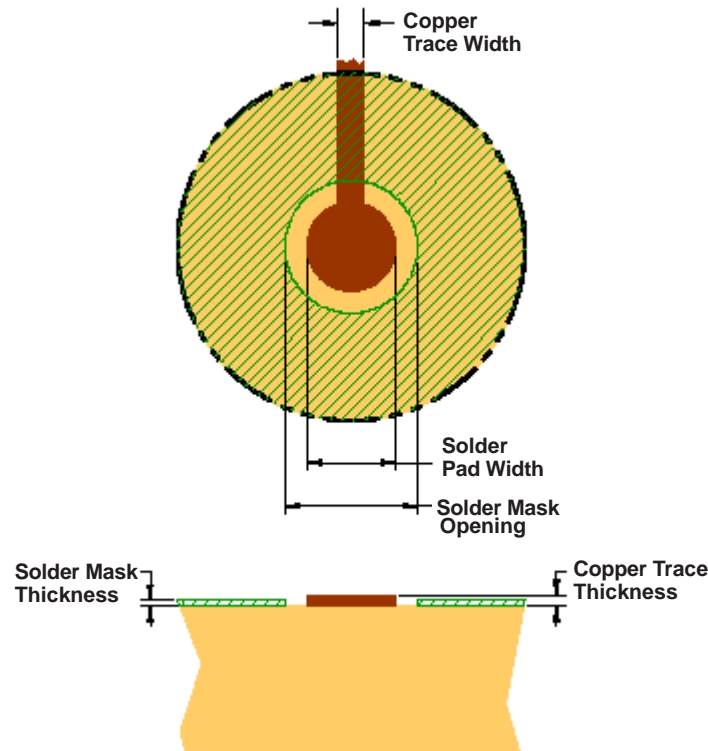

Figure 28. Land Pattern Dimensions

Table 5. Land Pattern Dimensions^{(1) (2) (3) (4)}

SOLDER PAD DEFINITIONS	COPPER PAD	SOLDER MASK ⁽⁵⁾ OPENING	COPPER THICKNESS	STENCIL ^{(6) (7)} OPENING	STENCIL THICKNESS
Nonsolder mask defined (NSMD)	275 μm (+0.0, -25 μm)	375 μm (+0.0, -25 μm)	1 oz max (32 μm)	275 μm x 275 μm Sq. (rounded corners)	125 μm thick

- (1) Circuit traces from NSMD defined PWB lands should be 75 μm to 100 μm wide in the exposed area inside the solder mask opening. Wider trace widths reduce device stand off and impact reliability.
- (2) Best reliability results are achieved when the PWB laminate glass transition temperature is above the operating the range of the intended application.
- (3) Recommend solder paste is Type 3 or Type 4.
- (4) For a PWB using a Ni/Au surface finish, the gold thickness should be less 0.5 μm to avoid a reduction in thermal fatigue performance.
- (5) Solder mask thickness should be less than 20 μm on top of the copper circuit pattern
- (6) Best solder stencil performance is achieved using laser cut stencils with electro polishing. Use of chemically etched stencils results in inferior solder paste volume control.
- (7) Trace routing away from WCSP device should be balanced in X and Y directions to avoid unintentional component movement due to solder wetting forces.

TRACE WIDTH

Recommended trace width at the solder balls is 75 μm to 100 μm to prevent solder wicking onto wider PCB traces. For high current pins (SW, GND, OUT+, OUT-, PVOU, and PVDD) of the TPA2015D1, use 100 μm trace widths at the solder balls and at least 500 μm PCB traces to ensure proper performance and output power for the device. For low current pins (IN-, IN+, END, ENB, GAIN, AGC, VBAT) of the TPA2015D1, use 75 μm to 100 μm trace widths at the solder balls. Run IN- and IN+ traces side-by-side (and if possible, same length) to maximize common-mode noise cancellation.



www.ti.com

PACKAG

PACKAGING INFORMATION

Orderable Device	Status ⁽¹⁾	Package Type	Package Drawing	Pins	Package Qty	Eco Plan ⁽²⁾	Lead/Ball Finish	MSL Peak Temp
TPA2015D1YZHR	ACTIVE	DSBGA	YZH	16	3000	Green (RoHS & no Sb/Br)	SNAGCU	Level-1-260C
TPA2015D1YZHT	ACTIVE	DSBGA	YZH	16	250	Green (RoHS & no Sb/Br)	SNAGCU	Level-1-260C

⁽¹⁾ The marketing status values are defined as follows:

ACTIVE: Product device recommended for new designs.

LIFEBUY: TI has announced that the device will be discontinued, and a lifetime-buy period is in effect.

NRND: Not recommended for new designs. Device is in production to support existing customers, but TI does not recommend using this part in a new design.

PREVIEW: Device has been announced but is not in production. Samples may or may not be available.

OBSOLETE: TI has discontinued the production of the device.

⁽²⁾ Eco Plan - The planned eco-friendly classification: Pb-Free (RoHS), Pb-Free (RoHS Exempt), or Green (RoHS & no Sb/Br) - please check <http://www.ti.com> for more information and additional product content details.

TBD: The Pb-Free/Green conversion plan has not been defined.

Pb-Free (RoHS): TI's terms "Lead-Free" or "Pb-Free" mean semiconductor products that are compatible with the current RoHS requirements for all RoHS materials, with the exception of lead not exceed 0.1% by weight in homogeneous materials. Where designed to be soldered at high temperatures, TI Pb-Free products are suitable for use in applications that require high temperature soldering processes.

Pb-Free (RoHS Exempt): This component has a RoHS exemption for either 1) lead-based flip-chip solder bumps used between the die and package, or 2) lead-based eutectic solder used between the leadframe and die. The component is otherwise considered Pb-Free (RoHS compatible) as defined above.

Green (RoHS & no Sb/Br): TI defines "Green" to mean Pb-Free (RoHS compatible), and free of Bromine (Br) and Antimony (Sb) based flame retardants (unless otherwise designated in homogeneous material).

⁽³⁾ MSL, Peak Temp. -- The Moisture Sensitivity Level rating according to the JEDEC industry standard classifications, and peak solder temperature.

Important Information and Disclaimer: The information provided on this page represents TI's knowledge and belief as of the date that it is provided. TI disclaims any warranty as to the accuracy of such information. Efforts are underway to better integrate information from third parties, and makes no representation or warranty as to the accuracy of such information. Efforts are underway to better integrate information from third parties, and makes no representation or warranty as to the accuracy of such information. TI continues to take reasonable steps to provide representative and accurate information but may not have conducted destructive testing or chemical analysis on all TI and TI suppliers consider certain information to be proprietary, and thus CAS numbers and other limited information may not be available for release.

In no event shall TI's liability arising out of such information exceed the total purchase price of the TI part(s) at issue in this document sold by TI to Customer.

TAPE AND REEL INFORMATION



QUADRANT ASSIGNMENTS FOR PIN 1 ORIENTATION IN TAPE



*All dimensions are nominal

Device	Package Type	Package Drawing	Pins	SPQ	Reel Diameter (mm)	Reel Width W1 (mm)	A0 (mm)	B0 (mm)	K0 (mm)	P1 (mm)	W (mm)	Pin1 Quadrant
TPA2015D1YZHR	DSBGA	YZH	16	3000	180.0	8.4	2.07	2.07	0.81	4.0	8.0	Q1
TPA2015D1YZHT	DSBGA	YZH	16	250	180.0	8.4	2.07	2.07	0.81	4.0	8.0	Q1

TAPE AND REEL BOX DIMENSIONS



*All dimensions are nominal

Device	Package Type	Package Drawing	Pins	SPQ	Length (mm)	Width (mm)	Height (mm)
TPA2015D1YZHR	DSBGA	YZH	16	3000	190.5	212.7	31.8
TPA2015D1YZHT	DSBGA	YZH	16	250	190.5	212.7	31.8

[查询"TPA2015D1"供应商](#)

YZH (S-XBGA-N16)

DIE-SIZE BALL GRID ARRAY

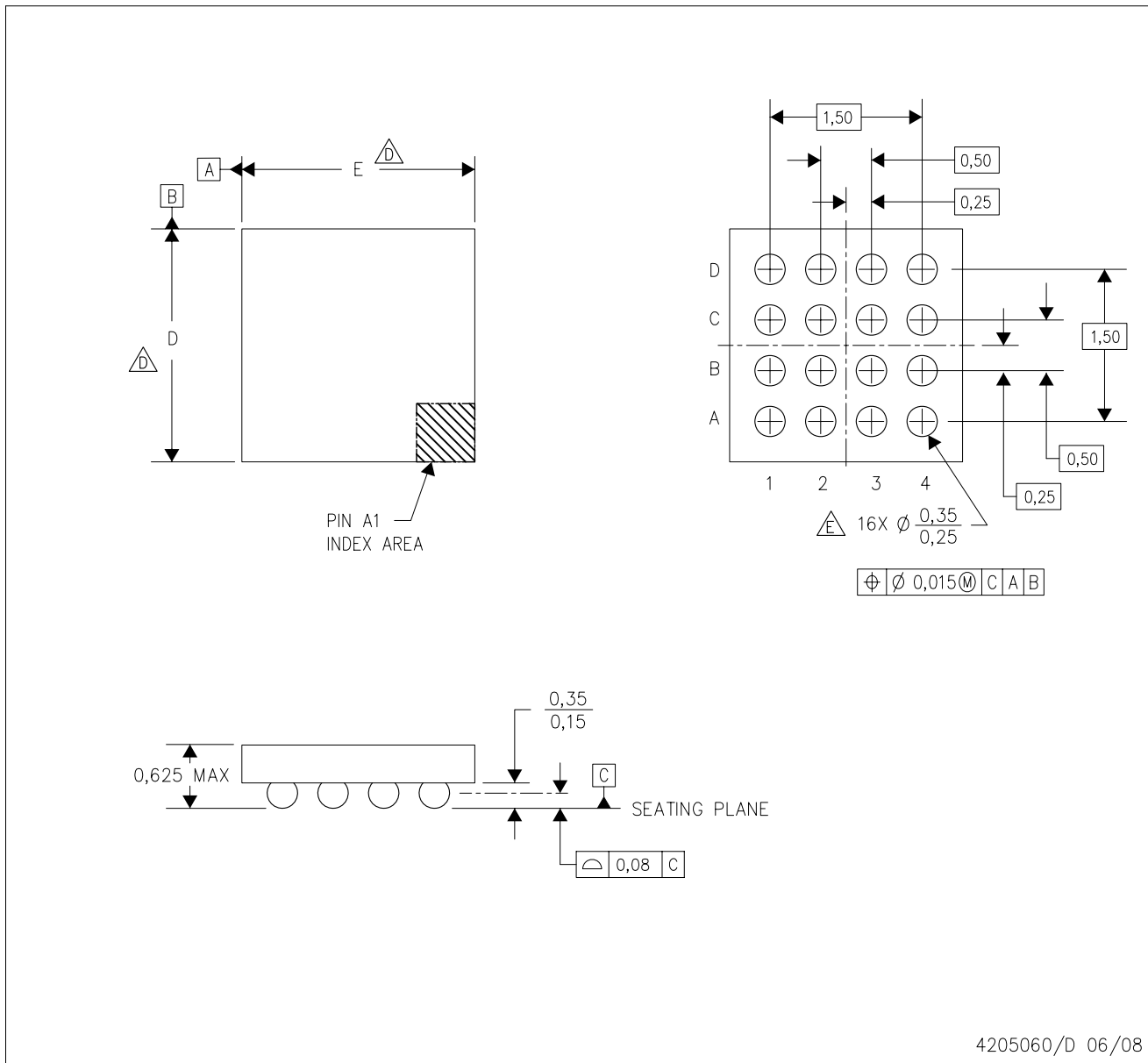

- NOTES:
- A. All linear dimensions are in millimeters.
 - B. This drawing is subject to change without notice.
 - C. NanoFree™ package configuration.
 - $\triangle D$ Devices in YZH package can have dimension D ranging from 1.94 to 2.65 mm and dimension E ranging from 1.94 to 2.65 mm. To determine the exact package size of a particular device, refer to the device datasheet or contact a local TI representative.
 - E. Reference Product Data Sheet for array population.
4 x 4 matrix pattern is shown for illustration only.
 - F. This package contains lead-free balls.
Refer to YEH (Drawing #4204183) for tin-lead (SnPb) balls.

NanoFree is a trademark of Texas Instruments.

IMPORTANT NOTICE

Texas Instruments Incorporated and its subsidiaries (TI) reserve the right to make corrections, modifications, enhancements, improvements, and other changes to its products and services at any time and to discontinue any product or service without notice. Customers should obtain the latest relevant information before placing orders and should verify that such information is current and complete. All products are sold subject to TI's terms and conditions of sale supplied at the time of order acknowledgment.

TI warrants performance of its hardware products to the specifications applicable at the time of sale in accordance with TI's standard warranty. Testing and other quality control techniques are used to the extent TI deems necessary to support this warranty. Except where mandated by government requirements, testing of all parameters of each product is not necessarily performed.

TI assumes no liability for applications assistance or customer product design. Customers are responsible for their products and applications using TI components. To minimize the risks associated with customer products and applications, customers should provide adequate design and operating safeguards.

TI does not warrant or represent that any license, either express or implied, is granted under any TI patent right, copyright, mask work right, or other TI intellectual property right relating to any combination, machine, or process in which TI products or services are used. Information published by TI regarding third-party products or services does not constitute a license from TI to use such products or services or a warranty or endorsement thereof. Use of such information may require a license from a third party under the patents or other intellectual property of the third party, or a license from TI under the patents or other intellectual property of TI.

Reproduction of TI information in TI data books or data sheets is permissible only if reproduction is without alteration and is accompanied by all associated warranties, conditions, limitations, and notices. Reproduction of this information with alteration is an unfair and deceptive business practice. TI is not responsible or liable for such altered documentation. Information of third parties may be subject to additional restrictions.

Resale of TI products or services with statements different from or beyond the parameters stated by TI for that product or service voids all express and any implied warranties for the associated TI product or service and is an unfair and deceptive business practice. TI is not responsible or liable for any such statements.

TI products are not authorized for use in safety-critical applications (such as life support) where a failure of the TI product would reasonably be expected to cause severe personal injury or death, unless officers of the parties have executed an agreement specifically governing such use. Buyers represent that they have all necessary expertise in the safety and regulatory ramifications of their applications, and acknowledge and agree that they are solely responsible for all legal, regulatory and safety-related requirements concerning their products and any use of TI products in such safety-critical applications, notwithstanding any applications-related information or support that may be provided by TI. Further, Buyers must fully indemnify TI and its representatives against any damages arising out of the use of TI products in such safety-critical applications.

TI products are neither designed nor intended for use in military/aerospace applications or environments unless the TI products are specifically designated by TI as military-grade or "enhanced plastic." Only products designated by TI as military-grade meet military specifications. Buyers acknowledge and agree that any such use of TI products which TI has not designated as military-grade is solely at the Buyer's risk, and that they are solely responsible for compliance with all legal and regulatory requirements in connection with such use.

TI products are neither designed nor intended for use in automotive applications or environments unless the specific TI products are designated by TI as compliant with ISO/TS 16949 requirements. Buyers acknowledge and agree that, if they use any non-designated products in automotive applications, TI will not be responsible for any failure to meet such requirements.

Following are URLs where you can obtain information on other Texas Instruments products and application solutions:

Products		Applications	
Amplifiers	amplifier.ti.com	Audio	www.ti.com/audio
Data Converters	dataconverter.ti.com	Automotive	www.ti.com/automotive
DLP® Products	www.dlp.com	Communications and Telecom	www.ti.com/communications
DSP	dsp.ti.com	Computers and Peripherals	www.ti.com/computers
Clocks and Timers	www.ti.com/clocks	Consumer Electronics	www.ti.com/consumer-apps
Interface	interface.ti.com	Energy	www.ti.com/energy
Logic	logic.ti.com	Industrial	www.ti.com/industrial
Power Mgmt	power.ti.com	Medical	www.ti.com/medical
Microcontrollers	microcontroller.ti.com	Security	www.ti.com/security
RFID	www.ti-rfid.com	Space, Avionics & Defense	www.ti.com/space-avionics-defense
RF/IF and ZigBee® Solutions	www.ti.com/lprf	Video and Imaging	www.ti.com/video
		Wireless	www.ti.com/wireless-apps