

Non-aliasing, 16- & 20-bit A/D Converters

Features

- Monolithic CMOS ADC with Filtering
 - 6-pole, Low-pass Gaussian Filter
- Up to 4 kHz Output Word Rates
 - On Chip Self-calibration Circuitry
 - Linearity Error: $\pm 0.0003\%$
 - Differential Nonlinearity:
 - CS5501: 16-bit, No Missing Codes (DNL $\pm 1/8$ LSB)
 - CS5503: 20-bit, No Missing Codes
- System Calibration Capability
- Flexible Serial Communications Port
 - Microcontroller-compatible Formats
 - 3-state Data and Clock Outputs
 - UART Format (CS5501 only)
- Pin-selectable Unipolar/Bipolar Ranges
- Low Power Consumption: 25 mW
 - 10 μ W Sleep Mode for Portable Applications

Description

The CS5501 and CS5503 are CMOS A/D converters ideal for measuring low-frequency signals representing physical, chemical, and biological processes. They utilize charge-balance techniques to achieve 16-bit (CS5501) and 20-bit (CS5503) performance with up to 4 kSps word rates.

The converters continuously sample at a rate set by the user in the form of either a CMOS clock or a crystal. On-chip digital filtering processes the data and updates the output register at up to a 4 kSps rate. The converters' low-pass, 6-pole Gaussian response filter is designed to allow corner frequency settings from 0.1 Hz to 10 Hz in the CS5501 and 0.5 Hz to 10 Hz in the CS5503. Thus, each converter rejects 50 Hz and 60 Hz line frequencies as well as any noise at spurious frequencies.

The CS5501 and CS5503 include on-chip self-calibration circuitry which can be initiated at any time or temperature to insure offset and full-scale errors of typically less than 1/2 LSB for the CS5501 and less than 4 LSB for the CS5503. The devices can also be applied in system calibration schemes to null offset and gain errors in the input channel.

Each device's serial port offers two general purpose modes of operation for direct interface to shift registers or synchronous serial ports of industry-standard microcontrollers. In addition, the CS5501's serial port offers a third, UART-compatible mode of asynchronous communication.

ORDERING INFORMATION

See page 33.

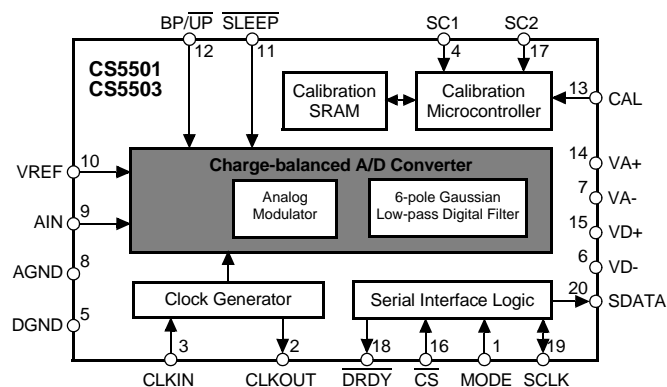

CS5501 ANALOG CHARACTERISTICS (TA = TMIN to TMAX; VA+, VD+ = 5V; VA-, VD- = -5V; VREF = 2.5V; CLKIN = 4.096MHz; Bipolar Mode; MODE = +5V; Rsource = 750Ω with a 1nF to AGND at AIN (see Note 1); Digital Inputs: Logic 0 = GND; Logic 1 = VD+; unless otherwise specified.)

Parameter*	CS5501-A, B, C			CS5501-S, T			Units	
	Min	Typ	Max	Min	Typ	Max		
Specified Temperature Range	-40 to +85			-55 to +125			°C	
Accuracy								
Linearity Error	-A, S	-	0.0015	0.003	-	-	0.003	±%FS
	-B, T	-	0.0007	0.0015	-	0.0007	0.0015	±%FS
	-C	-	0.0003	0.0012	-	-	-	±%FS
Differential Nonlinearity	TMIN to TMAX	-	±1/8	±1/2	-	±1/8	±1/2	LSB16
Full Scale Error	(Note 2)	-	±0.13	±0.5	-	±0.13	±0.5	LSB16
Full Scale Drift	(Note 3)	-	±1.2	-	-	±2.3	-	LSB16
Unipolar Offset	(Note 2)	-	±0.25	±1	-	±0.25	±1	LSB16
Unipolar Offset Drift	(Note 3)	-	±4.2	-	-	+3.0 -25.0	-	LSB16
Bipolar Offset	(Note 2)	-	±0.25	±1	-	±0.25	±1	LSB16
Bipolar Offset Drift	(Note 3)	-	±2.1	-	-	+1.5 -12.5	-	LSB16
Bipolar Negative Full Scale Error	(Note 2)	-	±0.5	±2	-	±0.5	±2	LSB16
Bipolar Negative Full Scale Drift	(Note 3)	-	±0.6	-	-	±1.2	-	LSB16
Noise (Referred to Output)		-	1/10	-	-	1/10	-	LSBrms

- Notes: 1. The AIN pin presents a very high input resistance at dc and a minor dynamic load which scales to the master clock frequency. Both source resistance and shunt capacitance are therefore critical in determining the CS5501's source impedance requirements. For more information refer the text section *Analog Input Impedance Considerations*.
2. Applies after calibration at the temperature of interest.
3. Total drift over the specified temperature range since calibration at power-up at 25°C (see Figure 11). This is guaranteed by design and /or characterization. Recalibration at any temperature will remove these errors.

μV	Unipolar Mode			Bipolar Mode		
	LSB's	%FS	ppm FS	LSB's	%FS	ppm FS
10	0.26	0.0004	4	0.13	0.0002	2
19	0.50	0.0008	8	0.26	0.0004	4
38	1.00	0.0015	15	0.50	0.0008	8
76	2.00	0.0030	30	1.00	0.0015	15
152	4.00	0.0061	61	2.00	0.0030	30

CS5501 Unit Conversion Factors, VREF = 2.5V

* Refer to the Specification Definitions immediately following the Pin Description Section.

CS5503 ANALOG CHARACTERISTICS (TA = TMIN to TMAX; VA+, VD+ = 5V; VA-, VD- = -5V; VREF = 2.5V; CLKIN = 4.096MHz; Bipolar Mode; MODE = +5V; Rsource = 750. with a 1nF to AGND at AIN (see Note 1): unless otherwise specified.)

Parameter*	CS5503-A, B, C			CS5503-S, T			Units	
	Min	Typ	Max	Min	Typ	Max		
Specified Temperature Range	-40 to +85			-55 to +125			°C	
Accuracy								
Linearity Error	-A, S	-	0.0015	0.003	-	-	0.003	±%FS
	-B, T	-	0.0007	0.0015	-	0.0007	TBD	±%FS
	-C	-	0.0003	0.0012	-	-	-	±%FS
Differential Nonlinearity (Not Missing Codes)	TMIN to TMAX	-	20	-	-	20	-	Bits
Full Scale Error	(Note 2)	-	±4	±16	-	±4	±16	LSB20
Full Scale Error Drift	(Note 3)	-	±19	-	-	±37	-	LSB20
Unipolar Offset	(Note 2)	-	±4	±16	-	±4	±16	LSB20
Unipolar Offset Drift	(Note 3)	-	±67	-	-	+48 -400	-	LSB20
Bipolar Offset	(Note 2)	-	±4	±16	-	±4	±16	LSB20
Bipolar Offset Drift	(Note 3)	-	±34	-	-	+24 -200	-	LSB20
Bipolar Negative Full Scale Error	(Note 2)	-	±8	±32	-	±8	±32	LSB20
Bipolar Negative Full Scale Drift	(Note 3)	-	±10	-	-	±20	-	LSB20
Noise (Referred to Output)		-	1.6	-	-	1.6	-	LSBrms (20)

. V	Unipolar Mode			Bipolar Mode		
	LSB's	%FS	ppm Fs	LSB's	%FS	ppm FS
0.596	0.25	0.0000238	0.24	0.13	0.0000119	0.12
1.192	0.50	0.0000477	0.47	0.26	0.0000238	0.24
2.384	1.00	0.0000954	0.95	0.50	0.0000477	0.47
4.768	2.00	0.0001907	1.91	1.00	0.0000954	0.95
9.537	4.000	0.0003814	3.81	2.00	0.0001907	1.91

CS5503 Unit Conversion Factors, VREF = 2.5V

* Refer to the Specification Definitions immediately following the Pin Description Section.

ANALOG CHARACTERISTICS (Continued)

Parameter*	CS5501/3-A, B, C			CS5501/3-S, T			Units
	Min	Typ	Max	Min	Typ	Max	
Power Supplies							
DC Power Supply Currents							
IA+	-	2	3.2	-	2	3.2	mA
IA-	-	2	3.2	-	2	3.2	mA
ID+	-	1	1.5	-	1	1.5	mA
ID- (Note 4)	-	0.03	0.1	-	0.03	0.1	mA
Power Dissipation							
SLEEP High	-	25	40	-	25	40	mW
SLEEP Low (Note 4)	-	10	20	-	10	40	μW
Power Supply Rejection							
Positive Supplies	-	70	-	-	70	-	dB
Negative Supplies (Note 5)	-	75	-	-	75	-	dB
Analog Input							
Analog Input Range							
Unipolar	0 to +2.5			0 to +2.5			V
Bipolar	-	±2.5	-	-	±2.5	-	V
Input Capacitance	-	20	-	-	20	-	pF
DC Bias Current (Note 1)	-	1	-	-	1	-	nA
System Calibration Specifications							
Positive Full Scale Calibration Range	VREF+0.1			VREF+0.1			V
Positive Full Scale Input Overrange	VREF+0.1			VREF+0.1			V
Negative Full Scale Input Overrange	-(VREF+0.1)			-(VREF+0.1)			V
Maximum Offset Calibration Range (Notes 6, 7)							
Unipolar Mode	-(VREF +0.1)			-(VREF +0.1)			V
Bipolar Mode	-40%VREF to +40%VREF			-40%VREF to +40%VREF			V
Input Span (Note 8)	80% VREF	2VREF +0.2		80% VREF	2VREF +0.2		V

- Notes: 4. All outputs unloaded.
5. 0.1Hz to 10Hz. PSRR at 60 Hz will exceed 120 dB due to the benefit of the digital filter.
6. In unipolar mode the offset can have a negative value (-VREF) such that the unipolar mode can mimic bipolar mode operation.
7. The specifications for Input Overrange and for Input Span apply additional constraints on the offset calibration range.
8. For Unipolar mode, Input Span is the difference between full scale and zero scale. For Bipolar mode, Input Span is the difference between positive and negative full scale points. When using less than the maximum input span, the span range may be placed anywhere within the range of $\pm(VREF + 0.1)$.

Specifications are subject to change without notice.

DYNAMIC CHARACTERISTICS

Parameter	Symbol	Ratio	Units
Sampling Frequency	f_s	CLKIN/ 256	Hz
Output Update Rate	f_{out}	CLKIN /1024	Sps
Filter Corner Frequency	f_{-3dB}	CLKIN /409,600	Hz
Settling Time to $\pm 0.0007\%$ FS (FS Step)	t_s	506,880/CLKIN	s

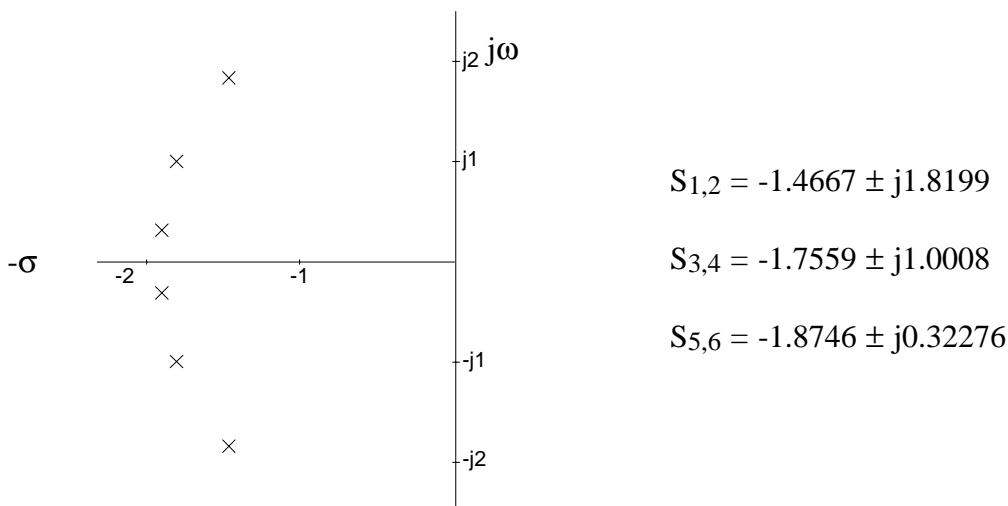
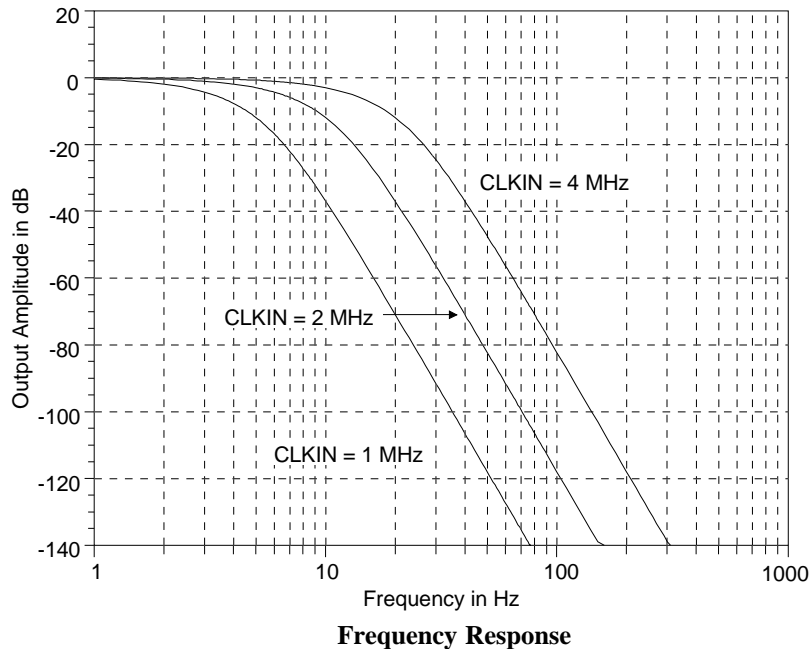

S-Domain Pole/Zero Plot (Continuous-Time Representation)

$$H(x) = [1 + 0.694x^2 + 0.241x^4 + 0.0557x^6 + 0.009664x^8 + 0.00134x^{10} + 0.000155x^{12}]^{-1/2}$$

where $x = f/f_{-3dB}$, $f_{-3dB} = \text{CLKIN}/409,600$, and f is the frequency of interest.

Continuous-Time Representation of 6-Pole Gaussian Filter

DIGITAL CHARACTERISTICS ($T_A = T_{min}$ to T_{max} ; V_{A+} , $V_{D+} = 5V \pm 10\%$; V_{A-} , $V_{D-} = -5V \pm 10\%$)

Parameter	Symbol	Min	Typ	Max	Units
Calibration Memory Retention Power Supply Voltage (V_{D+} and V_{A+})	VMR	2.0	-	-	V
High-Level Input Voltage All Except CLKIN	V_{IH}	2.0	-	-	V
High-Level Input Voltage CLKIN	V_{IH}	3.5	-	-	V
Low-Level Input Voltage All Except CLKIN	V_{IL}	-	-	0.8	V
Low-Level Input Voltage CLKIN	V_{IL}	-	-	1.5	V
High-Level Output Voltage (Note 9)	V_{OH}	$(V_{D+})-1.0V$	-	-	V
Low-Level Output Voltage $I_{out}=1.6mA$	V_{OL}	-	-	0.4	V
Input Leakage Current	I_{in}	-	-	10	μA
3-State Leakage Current	I_{OZ}	-	-	± 10	μA
Digital Output Pin Capacitance	C_{out}	-	9	-	pF

Notes: 9. $I_{out} = -100 \mu A$. This guarantees the ability to drive one TTL load. ($V_{OH} = 2.4V @ I_{out} = -40 \mu A$).

ABSOLUTE MAXIMUM RATINGS

Parameter	Symbol	Min	Max	Units	
DC Power Supplies:	Positive Digital	V_{D+}	-0.3	$(V_{A+})+0.3$	V
	Negative Digital	V_{D-}	0.3	-6.0	V
	Positive Analog	V_{A+}	-0.3	6.0	V
	Negative Analog	V_{A-}	0.3	-6.0	V
Input Current, Any Pin Except Supplies (Notes 10, 11)	I_{in}	-	± 10	mA	
Analog Input Voltage (A_{IN} and V_{REF} pins)	V_{INA}	$(V_{A-})-0.3$	$(V_{A+})+0.3$	V	
Digital Input Voltage	V_{IND}	-0.3	$(V_{A+})+0.3$	V	
Ambient Operating Temperature	T_A	-55	125	$^{\circ}C$	
Storage Temperature	T_{stg}	-65	150	$^{\circ}C$	

Notes: 10. Applies to all pins including continuous overvoltage conditions at the analog input (A_{IN}) pin.

11. Transient currents of up to 100mA will not cause SCR latch-up. Maximum input current for a power supply pin is ± 50 mA.

RECOMMENDED OPERATING CONDITIONS (AGND, DGND = 0V) (Note 12)

Parameter		Symbol	Min	Typ	Max	Units
DC Power Supplies:	Positive Digital	VD+	4.5	5.0	VA+	V
	Negative Digital	VD-	-4.5	-5.0	-5.5	V
	Positive Analog	VA+	4.5	5.0	5.5	V
	Negative Analog	VA-	-4.5	-5.0	-5.5	V
Analog Reference Voltage		VREF	1.0	2.5	3.0	V
Analog Input Voltage: (Note 13)						
	Unipolar	VAIN	AGND	-	VREF	V
	Bipolar	VAIN	-VREF	-	VREF	V

Notes: 12. All voltages with respect to ground.

13. The CS5501 and CS5503 can accept input voltages up to the analog supplies (VA+ and VA-). They will accurately convert and filter signals with noise excursions up to 100mV beyond |VREF|. After filtering, the devices will output all 1's for any input above VREF and all 0's for any input below AGND in unipolar mode and -VREF in bipolar mode.

SWITCHING CHARACTERISTICS (TA = T_{min} to T_{max}; CLKIN=4.096 MHz; VA+, VD+ = 5V±10%; VA-, VD- = -5V ± 10%; Input Levels: Logic 0 = 0V, Logic 1 = VD+; CL = 50 pF; unless otherwise specified.)

Parameter		Symbol	Min	Typ	Max	Units
Master Clock Frequency:	Internal Gate Oscillator (See Table 1)	CLKIN	200	4096	5000	kHz
	Externally Supplied: (Note 14)					
	Maximum	CLKIN	-	-	5000	kHz
	Minimum (Note 15)	CLKIN	200	40	-	kHz
CLKIN Duty Cycle			20	-	80	%
Rise Times:	Any Digital Input	trise	-	-	1.0	µs
	Any Digital Output (Note 16)	trise	-	20	-	ns
Fall Times:	Any Digital Input	tfall	-	-	1.0	µs
	Any Digital Output (Note 16)	tfall	-	20	-	ns
Set Up Times:	SC1, SC2 to CAL Low	tscs	100	-	-	ns
	SLEEP High to CLKIN High (Note 17)	tsls	1	-	-	µs
Hold Time:	SC1, SC2 hold after CAL falls	tsch	100	-	-	ns

Notes: 14. CLKIN must be supplied whenever the CS5501 or CS5503 is not in SLEEP mode. If no clock is present when not in SLEEP mode, the device can draw higher current than specified and possibly become uncalibrated.

15. The CS5501/CS5503 is production tested at 4.096 MHz. It is guaranteed by characterization to operate at 200 kHz.

16. Specified using 10% and 90% points on waveform of interest.

17. In order to synchronize several CS5501's or CS5503's together using the SLEEP pin, this specification must be met.

SWITCHING CHARACTERISTICS (continued) ($T_A = T_{min}$ to T_{max} ; $V_{A+}, V_{D+} = 5V \pm 10\%$; $V_{A-}, V_{D-} = -5V \pm 10\%$; Input Levels: Logic 0 = 0V, Logic 1 = V_{D+} ; $C_L = 50$ pF)

Parameter		Symbol	Min	Typ	Max	Units
SSC Mode (Mode = V_{D+})						
Access Time	CS Low to SDATA Out	tcsd1	3/CLKIN	-	-	ns
SDATA Delay Time	SCLK Falling to New SDATA bit	tdd1	-	25	100	ns
SCLK Delay Time (at 4.096 MHz)	SDATA MSB bit to SCLK Rising	tcd1	250	380	-	ns
Serial Clock (Out)	Pulse Width High (at 4.096 MHz)	tph1	-	240	300	ns
	Pulse Width Low	tpl1	-	730	790	
Output Float Delay	SCLK Rising to Hi-Z	tfd2	-	1/CLKIN + 100	1/CLKIN + 200	ns
Output Float Delay	CS High to Output Hi-Z (Note 18)	tfd1	-	-	4/CLKIN +200	ns
SEC Mode (Mode = DGND)						
Serial Clock (In)		f_sclk	dc	-	4.2	MHz
Serial Clock (In)	Pulse Width High	tph2	50	-	-	ns
	Pulse Width Low	tpl2	180	-	-	
Access Time	CS Low to Data Valid (Note 19)	tcsd2	-	80	160	ns
Maximum Data Delay Time	(Note 20) SCLK Falling to New SDATA bit	tdd2	-	75	150	ns
Output Float Delay	CS High to Output Hi-Z	tfd3	-	-	250	ns
Output Float Delay	SCLK Falling to Output Hi-Z	tfd4	-	100	200	ns

- Notes: 18. If \overline{CS} is returned high before all data bits are output, the SDATA and SCLK outputs will complete the current data bit and then go to high impedance.
19. If \overline{CS} is activated asynchronously to \overline{DRDY} , \overline{CS} will not be recognized if it occurs when \overline{DRDY} is high for 4 clock cycles. The propagation delay time may be as great as 4 CLKIN cycles plus 160 ns. To guarantee proper clocking of SDATA when using asynchronous \overline{CS} , SCLK(i) should not be taken high sooner than 4 CLKIN cycles plus 160ns after \overline{CS} goes low.
20. SDATA transitions on the falling edge of SCLK(i).

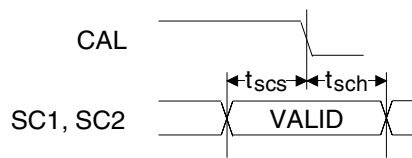

Calibration Control Timing

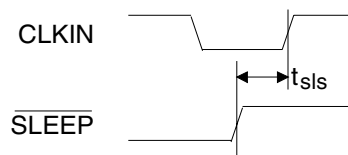

Sleep Mode Timing for Synchronization

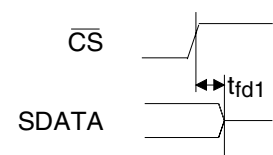

Output Float Delay SSC Mode (Note 19)

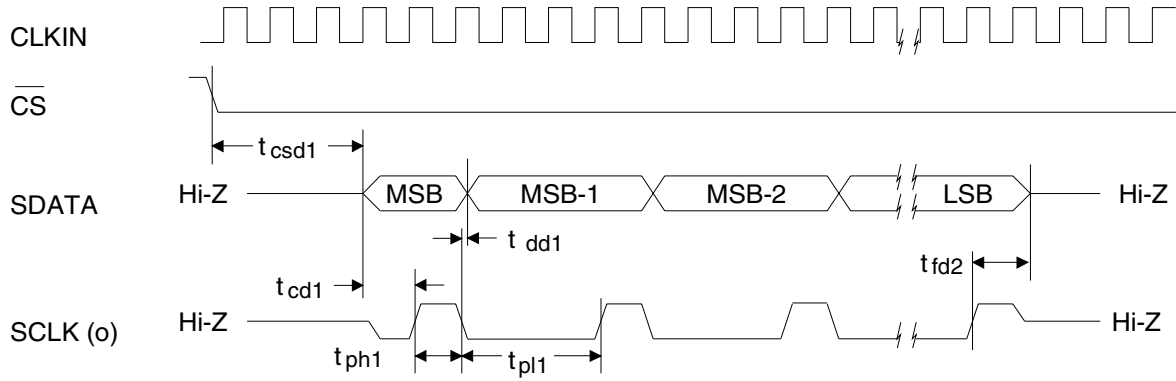

SSC MODE Timing Relationships

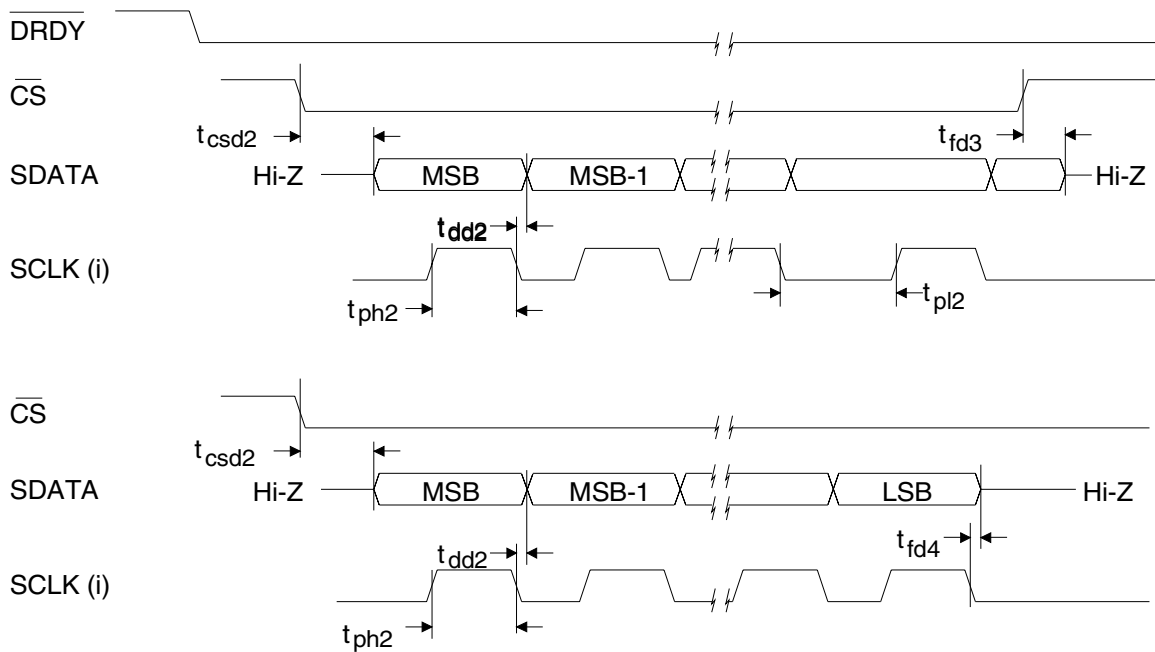

SEC MODE Timing Relationships

SWITCHING CHARACTERISTICS (continued) ($T_A = T_{min}$ to T_{max} ;
 $V_{A+}, V_{D+} = 5V \pm 10\%$; $V_{A-}, V_{D-} = -5V \pm 10\%$; Input Levels: Logic 0 = 0V, Logic 1 = V_{D+} ; $C_L = 50$ pF)

Parameter	Symbol	Min	Typ	Max	Units
AC Mode (Mode = VD-) CS5501 only					
Serial Clock (In)	f _{sclk}	dc	-	4.2	MHz
Serial Clock (In)	Pulse Width High	t _{ph3}	50	-	ns
	Pulse Width Low	t _{pl3}	180	-	ns
Set-up Time	CS Low to SCLK Falling	t _{css}	-	20	ns
Maximum Data Delay Time	SCLK Fall to New SDATA bit	t _{dd3}	-	90	ns
Output Float Delay	CS High to Output Hi-Z (Note 21)	t _{fd5}	-	100	ns

Notes: 21. If CS is returned high after an 11-bit data packet is started, the SDATA output will continue to output data until the end of the second stop bit. At that time the SDATA output will go to high impedance.

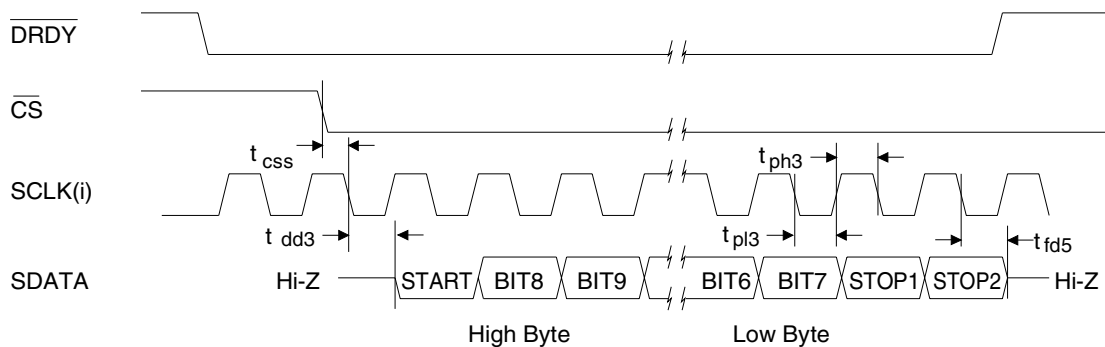

AC MODE Timing Relationships (CS5501 only)

GENERAL DESCRIPTION

The CS5501/CS5503 are monolithic CMOS A/D converters designed specifically for high resolution measurement of low-frequency signals. Each device consists of a charge-balance converter (16-Bit for the CS5501, 20-Bit for the CS5503), calibration microcontroller with on-chip SRAM, and serial communications port.

The CS5501/CS5503 A/D converters perform conversions continuously and update their output ports after every conversion (unless the serial port is active). Conversions are performed and the serial port is updated independent of external control. Both devices are capable of measuring either unipolar or bipolar input signals, and calibration cycles may be initiated at any time to ensure measurement accuracy.

The CS5501/CS5503 perform conversions at a rate determined by the master clock signal. The master clock can be set by an external clock or with a crystal connected to the pins of the on-chip gate oscillator. The master clock frequency determines:

1. The sample rate of the analog input signal.
2. The corner frequency of the on-chip digital filter.
3. The output update rate of the serial output port.

The CS5501/CS5503 design includes several self-calibration modes and several serial port interface modes to offer users maximum system design flexibility.

The Delta-Sigma Conversion Method

The CS5501/CS5503 A/D converters use charge-balance techniques to achieve low cost, high resolution measurements. A charge-balance A/D converter consists of two basic blocks: an analog modulator and a digital filter. An elementary example of a charge-balance A/D converter is a conventional voltage-to-frequency converter and counter. The VFC's 1-bit output conveys infor-

mation in the form of frequency (or duty cycle), which is then filtered (averaged) by the counter for higher resolution.

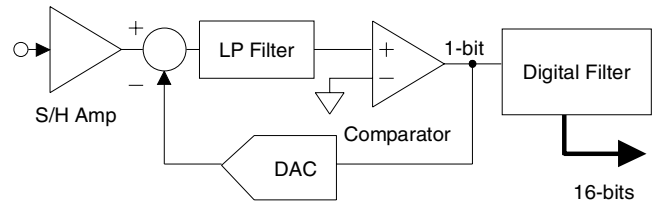

Figure 1. Charge Balance (Delta-Sigma) A/D Converter

The analog modulator of the CS5501/CS5503 is a multi-order delta-sigma modulator. The modulator consists of a 1-bit A/D converter (that is, a comparator) embedded in an analog feedback loop with high open loop gain (see Figure 1). The modulator samples and converts the input at a rate well above the bandwidth of interest. The 1-bit output of the comparator is sampled at intervals based on the clock rate of the part and this information (either a 1 or 0) is conveyed to the digital filter. The digital filter is much more sophisticated than a simple counter. The filter on the chip has a 6-pole low pass Gaussian response which rolls off at 120 dB/decade (36 dB/octave). The corner frequency of the digital filter scales with the master clock frequency. In comparison, VFC's and dual slope converters offer $(\sin x)/x$ filtering for high frequency rejection (see Figure 2 for a comparison of the characteristics of these two filter types). When operating from a 1 MHz master clock the digital filter in the CS5501/CS5503 offers better than 120 dB rejection of 50 and 60 Hz line frequencies and does not require any type of line synchronization to achieve this rejection. It should be noted that the CS5501/CS5503 will update its output port almost at 1000 times per second when operating from the 1 MHz clock. This is a much higher update rate (typically by a factor of at least 50 times) than either VFCs or dual-slope converters can offer.

For a more detailed discussion on the delta-sigma modulator see the Application note "Delta-Sigma

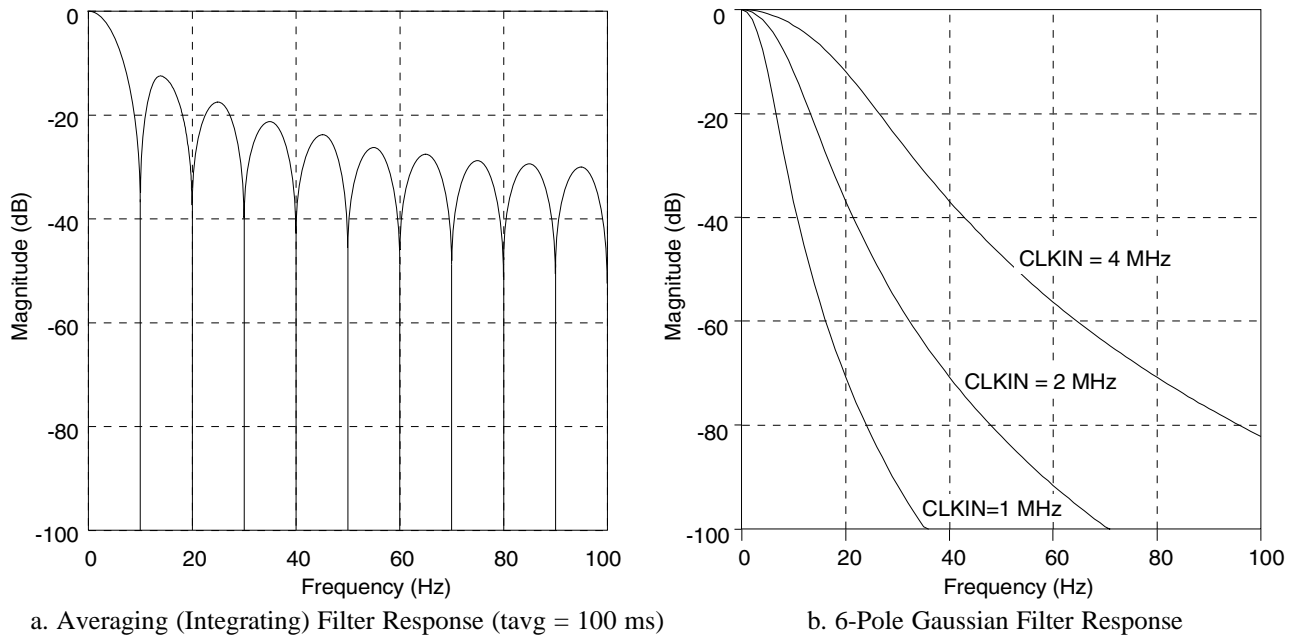

Figure 2. Filter Responses

A/D Conversion Technique Overview" in the application note section of the data book. The application note discusses the delta-sigma modulator and some aspects of digital filtering.

OVERVIEW

As shown in the block diagram on the front page of the data sheet, the CS5501/CS5503 can be segmented into five circuit functions. The heart of the chip is the charge balance A/D converter (16-bit for the CS5501, 20-bit for the CS5503). The converter and all of the other circuit functions on the chip must be driven by a clock signal from the clock generator. The serial interface logic outputs the converted data. The calibration microcontroller along with the calibration SRAM (static RAM), supervises the device calibration. Each segment of the chip has control lines associated with it. The function of each of the pins is described in the pin description section of the data sheet.

Clock Generator

The CS5501/CS5503 both include gates which can be connected as a crystal oscillator to provide the master clock signal for the chip. Alternatively, an external (CMOS compatible) clock can be input to the CLKIN pin as the master clock for the device. Figure 3 illustrates a simple model of the on-chip gate oscillator. The gate has a typical transconductance of 1500 μmho . The gate model includes 10 pF capacitors at the input and output pins. These capacitances include the typical stray capacitance of the pins of the device. The on-chip

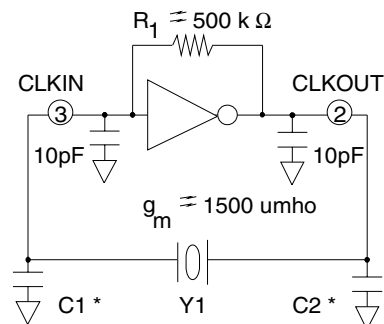

* See Table 1

Figure 3. On-chip Gate Oscillator Model

gate oscillator is designed to properly operate without additional loading capacitors when using a 4.096 MHz (or 4 MHz) crystal. If other crystal frequencies or if ceramic resonators are used, loading capacitors may be necessary for reliable operation of the oscillator. Table 1 illustrates some typical capacitor values to be used with selected resonating elements.

Resonators	C1	C2
Ceramic		
200 kHz	330pF	470pF
455 kHz	100pF	100pF
1.0 MHz	50pF	50pF
2.0 MHz	20pF	20pF
Crystals		
2.000 MHz	30pF	30pF
3.579 MHz	20pF	20pF
4.096 MHz	None	None

Table 1. Resonator Loading Capacitors

CLKOUT (pin 2) can be used to drive one external CMOS gate for system clock requirements. In this case, the external gate capacitance must be taken into account when choosing the value of C2.

Caution: A clock signal should always be present whenever the $\overline{\text{SLEEP}}$ is inactive ($\overline{\text{SLEEP}} = \text{VD}+$). If no clock is provided to the part when not in SLEEP, the part may draw excess current and possibly even lose its calibration data. This is because the device is built using dynamic logic.

Serial Interface Logic

The CS5501 serial data output can operate in any one of the following three different serial interface modes depending upon the MODE pin selection:

SSC (Synchronous Self-Clocking) mode;
MODE pin tied to VD+ (+5V).

SEC (Synchronous External Clocking) mode;
MODE pin tied to DGND.

and AC (Asynchronous Communication) mode;
CS5501 only
MODE pin tied to VD- (-5V)

The CS5503 can only operate in the first two modes, SEC and SSC.

Synchronous Self-Clocking Mode

When operated in the SSC mode (MODE pin tied to VD+), the CS5501/CS5503 furnish both serial output data (SDATA) and an internally-generated serial clock (SCLK). Internal timing for the SSC mode is illustrated in Figure 4. Figure 5 shows detailed SSC mode timing for both the CS5501/CS5503. A filter cycle occurs every 1024 cycles of CLKIN. During each filter cycle, the status of $\overline{\text{CS}}$ is polled at eight specific times during the cycle. If $\overline{\text{CS}}$ is low when it is polled, the CS5501/CS5503 begin clocking the data bits out, MSB first, at a SCLK output rate of CLKIN/4. Once transmission is complete, $\overline{\text{DRDY}}$ rises and both SDATA and SCLK outputs go into a high impedance state. A filter cycle begins each time $\overline{\text{DRDY}}$ falls. If the $\overline{\text{CS}}$ line is not active, $\overline{\text{DRDY}}$ will return high 1020 clock cycles after it falls. Four clock cycles later $\overline{\text{DRDY}}$ will fall to signal that the serial port has been updated with new data and that a new filter cycle has begun. The first $\overline{\text{CS}}$ polling during a filter cycle occurs 76 clock cycles after $\overline{\text{DRDY}}$ falls (the rising edge of CLKIN on which $\overline{\text{DRDY}}$ falls is considered clock cycle number one). Subsequent pollings of $\overline{\text{CS}}$ occur at intervals of 128 clock cycles thereafter (76, 204, 332, etc.). The $\overline{\text{CS}}$ signal is polled at the beginning of each of eight data output windows which occur in a filter cycle. To transmit data during any one of the eight output windows, $\overline{\text{CS}}$ must be low at least three CLKIN cycles before it is polled. If $\overline{\text{CS}}$ does not meet this set-up time, data will not be transmitted during the window time. Furthermore, $\overline{\text{CS}}$ is not latched internally and therefore must be held low during the entire data transmission to obtain all of the data bits.

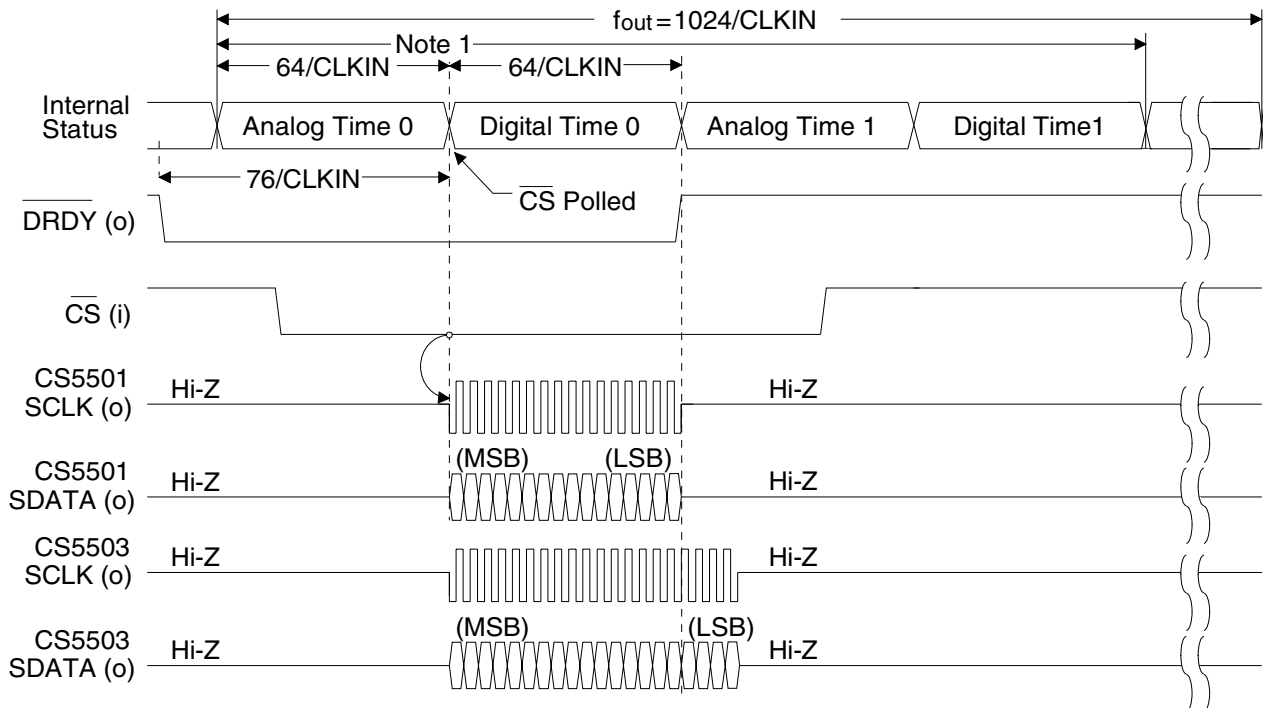

Note: 1. There are 16 analog and digital settling periods per filter cycle (4 are shown). Data can be output in the SSC mode in only 1 of the 8 digital time periods in each filter cycle.

Figure 4. Internal Timing

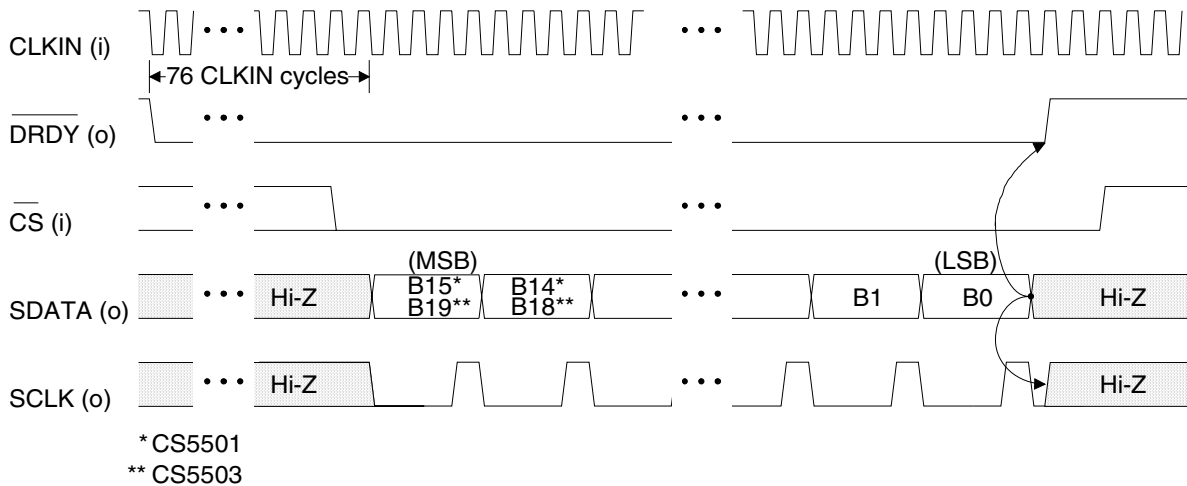

Figure 5. Synchronous Self-Clocking (SSC) Mode Timing

The eighth output window time overlaps the time in which the serial output port is to be updated. If the \overline{CS} is recognized as being low when it is polled for the eighth window time, data will be output as normal, but the serial port will not be updated with new data until the next serial port update time. Under these conditions, the serial port will experience an update rate of only 2 kSps

(CLKIN = 4.096 MHz) instead of the normal 4 kSps serial port update rate.

Upon completion of transmission of all the data bits, the SCLK and SDATA outputs will go to a high impedance state even with \overline{CS} held low. In the event that \overline{CS} is taken high before all data bits are output, the SDATA and SCLK outputs will

complete the current data bit output and go to a high impedance state when SCLK goes low.

Synchronous External Clocking Mode

When operated in the SEC mode (MODE pin tied to DGND), the CS5501/CS5503 outputs the data in its serial port at a rate determined by an external clock which is input into the SCLK pin. In this mode the output port will be updated every 1024 CLKIN cycles. \overline{DRDY} will go low when new data is loaded into the output port. If \overline{CS} is not active, \overline{DRDY} will return positive 1020 CLKIN cycles later and remain so for four CLKIN cycles. If \overline{CS} is taken low it will be recognized immediately unless it occurs while \overline{DRDY} is high for the four clock cycles. As soon as \overline{CS} is recognized, the SDATA output will come out of its high-impedance state and present the MSB data bit. The MSB data bit will remain present until a falling edge of SCLK occurs to advance the output to the MSB-1 bit. If the \overline{CS} and external SCLK are operated asynchronously to CLKIN, errors can result in the output data unless certain precautions are taken. If \overline{CS} is activated asynchronously, it may occur during the four clock cycles when \overline{DRDY} is high and therefore not be recognized immediately. To be certain that data misread errors will not result if \overline{CS} occurs at this time, the SCLK input should not transition high to latch the MSB until four CLKIN cycles plus 160 ns after \overline{CS} is taken low.

This insures that \overline{CS} will be recognized and the MSB bit will become stable before the SCLK transitions positive to latch the MSB data bit.

When SCLK returns low the serial port will present the MSB-1 data bit on its output. Subsequent cycles of SCLK will advance the data output. When all data bits are clocked out, \overline{DRDY} will then go high and the SDATA output will go into a high impedance state. If the \overline{CS} input goes low and all of the data bits are not clocked out of the port, filter cycles will continue to occur but the output serial port will not be updated with new data (\overline{DRDY} will remain low). If \overline{CS} is taken high at any time, the SDATA output pin will go to a high impedance state. If any of the data bits in the serial port have not been clocked out, they will remain available until \overline{DRDY} returns high for four clock cycles. After this \overline{DRDY} will fall and the port will be updated with a new 16-bit word in the CS5501 or 20-bit word in the CS5503. It is acceptable to clock out less than all possible data bits if \overline{CS} is returned high to allow the port to be updated. Figure 6 illustrates the serial port timing in the SEC mode.

Asynchronous Communication Mode (CS5501 Only)

In the CS5501, the AC mode is activated when the MODE pin is tied to VD- (-5 V). When operating in the AC mode the CS5501 is designed to

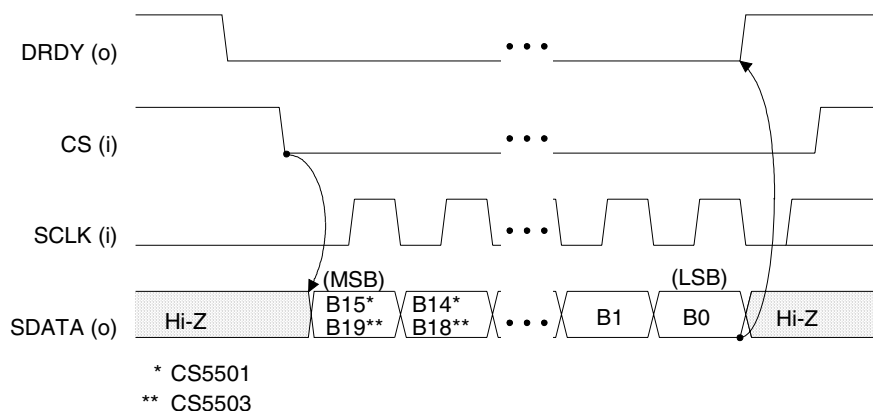

Figure 6. Synchronous External-Clocking (SEC) Mode Timing

provide data output in UART compatible format. The baud rate of the SDATA output will be determined by the rate of the SCLK input. The data which is output of the SDATA pin will be formatted such that it will contain two 11 bit data packets. Each packet includes one start bit, eight data bits, and two stop bits. The packet which carries the most-significant-byte data will be output first, with its lsb being the first data bit output after the start bit.

In this mode, $\overline{\text{DRDY}}$ will occur every 1024 clock cycles. If the serial port is not outputting a data byte, $\overline{\text{DRDY}}$ will return high after 1020 clock cycles and remain high for 4 clock cycles. $\overline{\text{DRDY}}$ will then go low to indicate that an update to the serial output port with a new 16 bit word has occurred. To initiate a transmission from the port the $\overline{\text{CS}}$ line must be taken low. Then SCLK, which is an input in this mode, must transition from a high to a low to latch the state of $\overline{\text{CS}}$ internal to the CS5501. Once $\overline{\text{CS}}$ is recognized and latched as a low, the port will begin to output data. Figure 7 details the timing for this output. $\overline{\text{CS}}$ can be returned high before the end of the 11-bit transmission and the transmission will continue until the second stop bit of the first 11-bit packet is output. The SDATA output will go into a high impedance state after the second stop bit is output. To obtain the second 11-bit packet $\overline{\text{CS}}$ must again be brought low before $\overline{\text{DRDY}}$ goes high or the second 11-bit data packet will be overwritten with

a serial port update. For the second 11-bit packet, $\overline{\text{CS}}$ need only to go low for 50 ns; it need not be latched by a falling edge of SCLK. Alternately, the $\overline{\text{CS}}$ line can be taken low and held low until both 11-bit data packets are output. This is the preferred method of control as it will prevent losing the second 11-bit data packet if the port is updated. Some serial data rates can be quite slow compared to the rate at which the CS5501 can update its output port. A slow data rate will leave only a short period of time to start the second 11-bit packet if $\overline{\text{CS}}$ is returned high momentarily. If $\overline{\text{CS}}$ is held low continuously ($\overline{\text{CS}}$ hard-wired to DGND), the serial port will be updated only after all 22 bits have been clocked out of the port.

Upon the completion of a transmission of the two 11-bit data packets the SDATA output will go into a high impedance state. If at any time during transmission the $\overline{\text{CS}}$ is taken back high, the current 11-bit data packet will continue to be output. At the end of the second stop bit of the data packet, the SDATA output will go into a high impedance state.

Linearity Performance

The CS5501/CS5503 delta-sigma converters are like conventional charge-balance converters in that they have no source of nonmonotonicity. The devices therefore have no missing codes in their transfer functions. See Figure 8 for a plot of the

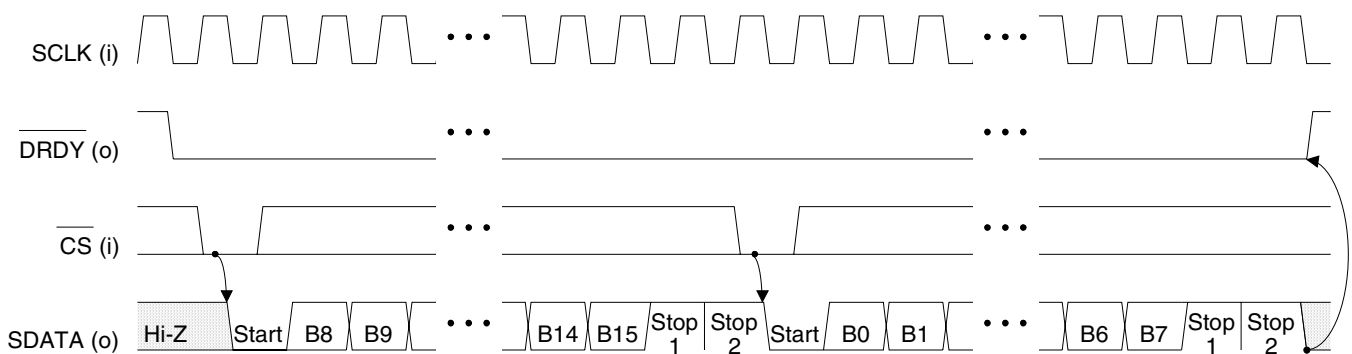

Figure 7. CS5501 Asynchronous (UART) Mode Timing

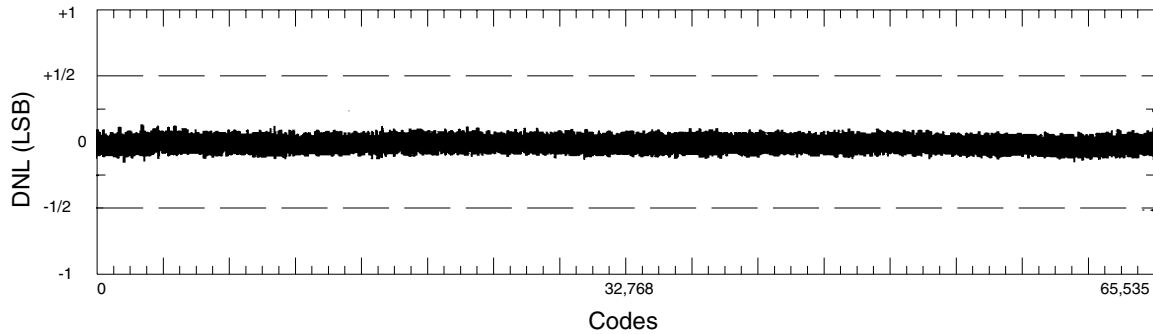

Figure 8. CS5501 Differential Nonlinearity Plot

excellent differential linearity achieved by the CS5501. The CS5501/CS5503 also have excellent integral linearity, which is accomplished with a well-designed charge-balance architecture. Each device also achieves low input drift through the use of chopper-stabilized techniques in its input stage. To assure that the CS5501/CS5503 achieves excellent performance over time and temperature, it uses digital calibration techniques to minimize offset and gain errors to typically within $\pm 1/2$ LSB at 16 bits in the CS5501 and ± 4 LSB at 20 bits in the CS5503.

Calibration

The CS5501/CS5503 offer both self-calibration and system level calibration capability. To understand the calibration features, a basic comprehension of the internal workings of the converter are helpful. As mentioned previously in this data sheet, the converter consists of two sections. First is the analog modulator which is a delta-sigma type charge-balance converter. This is followed by a digital filter. The filter circuitry is actually an arithmetic logic unit (ALU) whose architecture and instructions execute the filter function. The modulator (explained in more detail in the applications note "Delta-Sigma Conversion Technique Overview") uses the VREF voltage connected to pin 10 to determine the magnitude of the voltages used in its feedback DAC. The modulator accepts an analog signal at its input and produces a data stream of 1's and 0's as its output. This data stream value can change

(from 1 to 0 or vice versa) every 256 CLKIN cycles. As the input voltage increases the ratio of 1's to 0's out of the modulator increases proportionally. The 1's density of the data stream out of the modulator therefore provides a digital representation of the analog input signal where the 1's density is defined as the ratio of the number of 1's to the number of 0's out of the modulator for a given period of time. The 1's density output of the modulator is also a function of the voltage on the VREF pin. If the voltage on the VREF pin increases in value (say, due to temperature drift), and the analog input voltage into the modulator remains constant, the 1's density output of the modulator will decrease (less 1's will occur). The analog input into the modulator which is necessary to produce a given binary output code from the converter is ratiometric to the voltage on the VREF pin. This means that if VREF increases by one per cent, the analog signal on AIN must also increase by one per cent to maintain the same binary output code from the converter.

For a complete calibration to occur, the calibration microcontroller inside the device needs to record the data stream 1's density out of the modulator for two different input conditions. First, a "zero scale" point must be presented to the modulator. Then a "full scale" point must be presented to the modulator. In unipolar self-cal mode the zero scale point is AGND and the full scale point is the voltage on the VREF pin. The calibration microcontroller then remembers the 1's density out of the modulator for each of these points and calculates a slope factor (LSB/ μ V). This slope factor

represents the gain slope for the input to output transfer function of the converter. In unipolar mode the calibration microcontroller determines the slope factor by dividing the span between the zero point and the full scale point by the total resolution of the converter (2^{16} for the CS5501, resulting in 65,536 segments or 2^{20} for the CS5503, resulting in 1,048,578 segments). In bipolar mode the calibration microcontroller divides the span between the zero point and the full scale point into 524,288 segments for the CS5503 and 32,768 segments for the CS5501. It then extends the measurement range 524,288 segments for the CS5503, 32,768 segments for the CS5501, below the zero scale point to achieve bipolar measurement capability. In either unipolar or bipolar modes the calculated slope factor is saved and later used to calculate the binary output code when an analog signal is present at the AIN pin during measurement conversions.

System calibration allows the A/D converter to compensate for system gain and offset errors (see

Figure 9). System calibration performs the same slope factor calculations as self-cal but uses voltage values presented by the system to the AIN pin for the zero scale point and for the full scale point. Table 2 depicts the calibration modes available. Two system calibration modes are listed. The first mode offers system level calibration for system offset and for system gain. This is a two-step calibration. The zero scale point (system offset) must be presented to the converter first. The voltage that represents zero scale point must be input to the converter before the calibration step is initiated and must remain stable until the step is complete. The $\overline{\text{DRDY}}$ output from the converter will signal when the step is complete by going low. After the zero scale point is calibrated, the voltage representing the full scale point is input to the converter and the second calibration step is initiated. Again the voltage must remain stable throughout the calibration step.

This two-step calibration mode offers another calibration feature. After a two-step calibration

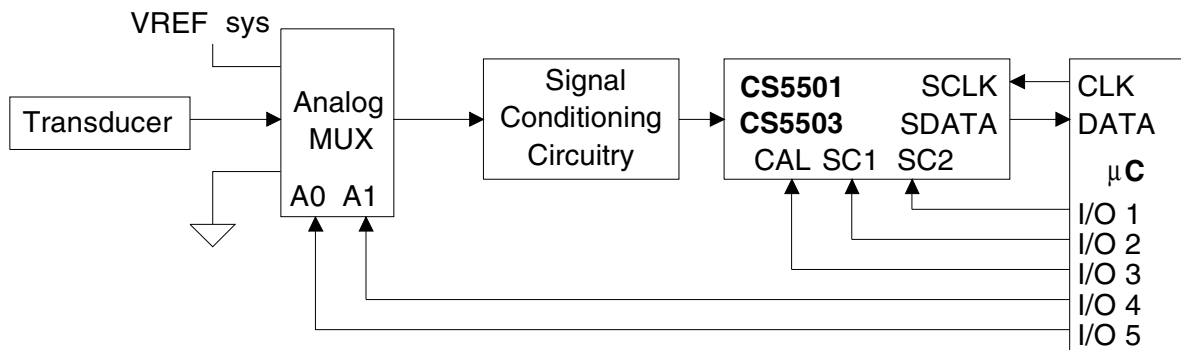

Figure 9. System Calibration

CAL	SC1	SC2	Cal Type	ZS Cal	FS Cal	Sequence	Calibration Time
↓	0	0	Self-Cal	AGND	VREF	One Step	$3,145,655/f_{\text{clk}}$
↓	1	1	System Offset & System Gain	AIN	-	1st Step	$1,052,599/f_{\text{clk}}$
↓	0	1		-	AIN	2nd Step	$1,068,813/f_{\text{clk}}$
↓	1	0	System Offset	AIN	VREF	One Step	$2,117,389/f_{\text{clk}}$

* $\overline{\text{DRDY}}$ remains high throughout the calibration sequence. In Self-Cal mode (SC1 and SC2 low) $\overline{\text{DRDY}}$ falls once the CS5501 or CS5503 has settled to the analog input. In all other modes $\overline{\text{DRDY}}$ falls immediately after the calibration term has been determined.

Table 2. Calibration Control

sequence (system offset and system gain) has been properly performed, additional offset calibrations can be performed by themselves to reposition the gain slope (the slope factor is not changed) to adjust its zero reference point to the new system zero reference value.

A second system calibration mode is available which uses an input voltage for the zero scale calibration point, but uses the VREF voltage as the full scale calibration point.

Whenever a system calibration mode is used, there are limits to the amount of offset and to the amount of span which can be accommodated. The range of input span which can be accommodated in either unipolar or bipolar mode is restricted to not less than 80% of the voltage on VREF and not more than 200% of (VREF + 0.1) V. The amount of offset which can be calibrated depends upon whether unipolar or bipolar mode is being used. In unipolar mode the system calibration modes can handle offsets as positive as 20% of VREF (this is restricted by the minimum span requirement of 80% VREF) or as negative as -(VREF + 0.1) V. This capability enables the unipolar mode of the CS5501/CS5503 to be calibrated to mimic bipolar mode operation.

In the bipolar mode the system offset calibration range is restricted to a maximum of $\pm 40\%$ of VREF. It should be noted that the span restrictions limit the amount of offset which can be calibrated. The span range of the converter in bipolar mode extends an equidistance (+ and -) from the voltage used for the zero scale point. When the zero scale point is calibrated it must not cause either of the two endpoints of the bipolar transfer function to exceed the positive or the negative input overrange points (+ (VREF + 0.1) V or - (VREF + 0.1) V). If the span range is set to a minimum (80% VREF) the offset voltage can move $\pm 40\%$ VREF without causing the end points of the transfer function to exceed the overrange points. Alternatively, if the span range is set to 200% of

VREF, the input offset cannot move more than +0.1 or - 0.1 V before an endpoint of the transfer function exceeds the input overrange limit.

Initiating Calibration

Table 2 illustrates the calibration modes available in the CS5501/CS5503. Not shown in the table is the function of the BP/UP pin which determines whether the converter is calibrated to measure bipolar or unipolar signals. A calibration step is initiated by bringing the CAL pin (13) high for at least 4 CLKIN cycles to reset the part and then bringing CAL low. The states of SC1 (pin 4) and SC2 (pin 17) along with the BP/UP (pin 12) will determine the type of calibration to be performed. The SC1 and SC2 inputs are latched when CAL goes low. The BP/UP input is not latched and therefore must remain in a fixed state throughout the calibration and measurement cycles. Any time the state of the BP/UP pin is changed, a new calibration cycle must be performed to enable the CS5501/CS5503 to properly function in the new mode.

When a calibration step is initiated, the $\overline{\text{DRDY}}$ signal will go high and remain high until the step is finished. Table 2 illustrates the number of clock cycles each calibration requires. Once a calibration step is initiated it must finish before a new calibration step can be executed. In the two step system calibration mode, the offset calibration step must be initiated before initiating the gain calibration step.

When a self-cal is completed $\overline{\text{DRDY}}$ falls and the output port is updated with a data word that represents the analog input signal at the AIN pin. When a system calibration step is completed, $\overline{\text{DRDY}}$ will fall and the output port will be updated with the appropriate data value (zero scale point, or full scale point). In the system calibration mode, the digital filter must settle before the output code will represent the value of the analog input signal.

Cal Mode	Zero Scale	Gain Factor	1LSB			
			Unipolar		Bipolar	
			CS5501	CS5503	CS5501	CS5503
Self-Cal	AGND	VREF	$\frac{VREF}{65,536}$	$\frac{VREF}{1,048,526}$	$\frac{2VREF}{65,536}$	$\frac{2VREF}{1,048,526}$
System Cal	SOFF	SGAIN	$\frac{SGAIN-SOFF}{65,536}$	$\frac{SGAIN-SOFF}{1,048,526}$	$\frac{2(SGAIN-SOFF)}{65,536}$	$\frac{2(SGAIN-SOFF)}{1,048,526}$

Table 3. Output Code Size After Calibration

Input Voltage, Unipolar Mode			Input Voltage, Bipolar Mode		
System-Cal	Self-Cal	Output Codes (Hex)		Self-Cal	System Cal
		CS5501	CS5503		
>(SGAIN - 1.5 LSB)	>(VREF - 1.5 LSB)	FFFF	FFFF	>(VREF - 1.5 LSB)	>(SGAIN - 1.5 LSB)
SGAIN - 1.5 LSB	VREF - 1.5 LSB	FFFF FFFE	FFFF FFFE	VREF - 1.5 LSB	SGAIN - 1.5 LSB
(SGAIN - SOFF)/2 - 0.5 LSB	VREF/2 - 0.5 LSB	8000 7FFF	8000 7FFF	AGND - 0.5 LSB	SOFF -0.5 LSB
SOFF + 0.5 LSB	AGND + 0.5 LSB	0001 0000	0001 0000	-VREF+ 0.5 LSB	-SGAIN + 2SOFF + 0.5 LSB
<(SOFF + 0.5 LSB)	<(AGND+0.5 LSB)	0000	0000	<(-VREF+0.5 LSB)	<(-SGAIN+2SOFF+0.5 LSB)

Table 4. Output Coding

Tables 3 and 4 indicate the output code size and output coding of the CS5501/CS5503 in its various modes. The calibration equations which represent the CS5501/CS5503 transfer function are shown in Figure 10.

$$DOUT = \text{Slope} (AIN - \text{Unipolar Offset}) + 0.5 \text{ LSB}$$

a. Unipolar Calibration

CS5501

$$DOUT = \text{Slope} (AIN - \text{Bipolar Offset}) + 2^{15} + 0.5 \text{ LSB}_{16}$$

CS5503

$$DOUT = \text{Slope}(AIN - \text{Bipolar Offset}) + 2^{19} + 0.5 \text{ LSB}_{20}$$

b. Bipolar Calibration

Figure 10. Calibration Equations

Underrange And Overage Considerations

The input signal range of the CS5501/CS5503 will be determined by the mode in which the part is calibrated. Table 4 indicates the input signal range in the various modes of operation. If the input signal exceeds the full scale point the converter will output all ones. If the signal is less than the zero scale point (in unipolar) or more negative in magnitude than minus the full scale point (in bipolar) it will output all zeroes.

Note that the modulator-filter combination in the chip CS5501/CS5503 is designed to accurately convert and filter input signals with noise excursions which extend up to 100 mV below the analog value which produces all zeros out or above the analog value which produces all ones out. Overage noise excursions greater than 100 mV may increase output noise.

All pins of the CS5501/CS5503 include diodes which clamp the input signals to within the positive and negative supplies. If a signal on any pin (including AIN) exceeds the supply voltage (either

+ or -) a clamp diode will be forward-biased. Under these fault conditions the CS5501/CS5503 might be damaged. Under normal operating conditions (with the power supplies established), the device will survive transient currents through the clamp diodes up to 100 mA and continuous currents up to 10 mA. The drive current into the AIN pin should be limited to a safe value if an over-voltage condition is likely to occur. See the application note "Buffer Amplifiers for the CS501X Series of A/D Converters" for further discussion on the clamp diode input structure and on current limiting circuits.

System Synchronization

If more than one CS5501/CS5503 is included in a system which is operating from a common clock, all of the devices can be synchronized to sample and output at exactly the same time. This can be accomplished in either of two ways. First, a single CAL signal can be issued to all the CS5501/CS5503's in the system. To insure synchronization on the same clock signal the CAL signal should go low on the falling edge of CLKIN. Or second, a common SLEEP control signal can be issued. If the SLEEP signal goes positive with the appropriate set up time to CLKIN, all parts will be synchronized on the same clock cycle.

Analog Input Impedance Considerations

The analog input of the CS5501/CS5503 can be modeled as illustrated in Figure 11. A 20 pF capacitor is used to dynamically sample the input signal. Every 64 CLKIN cycles the switch alternately connects the capacitor to the output of the buffer and then directly to the AIN pin. Whenever the sample capacitor is switched from the output of the buffer to the AIN pin, a small packet of charge (a dynamic demand of current) will be required from the input source to settle the voltage on the sample capacitor to its final value. The voltage at the output of the buffer may differ up to 100 mV from the actual input voltage due to

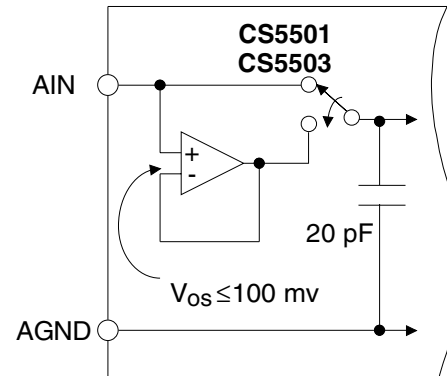

Figure 11. Analog Input Model

the offset voltage of the buffer. Timing allows 64 cycles of master clock (CLKIN) for the voltage on the sample capacitor to settle to its final value. The equation which defines settling time is:

$$V_e = V_{\max} e^{-t/RC}$$

Where V_e is the final settled value, V_{\max} is the maximum error voltage value of the input signal, R is the value of the input source resistance, C is the 20 pF sample capacitor plus the value of any stray or additional capacitance at the input pin. The value of t is equal to $64/\text{CLKIN}$.

V_{\max} occurs the instance when the sample capacitor is switched from the buffer output to the AIN pin. Prior to the switch, AIN has an error estimated as being less than or equal to V_e . V_{\max} is equal to the prior error (V_e) plus the additional error from the buffer offset. The estimate for V_{\max} is:

$$V_{\max} = V_e + 100\text{mV} \frac{20\text{pF}}{(20\text{pF} + C_{\text{EXT}})}$$

Where C_{EXT} is the combination of any external or stray capacitance.

From the equation which defines settling time, an equation for the maximum acceptable source resistance is derived

equation which defines settling time, an equation for the maximum acceptable source resistance is derived

$$R_{S_{max}} = \frac{-64}{\text{CLKIN}(20\text{pF}+C_{EXT}) \ln \left[\frac{V_e}{V_e + \frac{20\text{pF}(100\text{mV})}{(20\text{pF}+C_{EXT})}} \right]}$$

This equation assumes that the offset voltage of the buffer is 100 mV, which is the worst case. The value of V_e is the maximum error voltage which is acceptable.

For a maximum error voltage (V_e) of 10 μV in the CS5501 (1/4LSB at 16-bits) and 600 nV in the CS5503 (1/4LSB at 20-bits), the above equation indicates that when operating from a 4.096 MHz CLKIN, source resistances up to 84 k Ω in the CS5501 or 64 k Ω in the CS5503 are acceptable in the absence of external capacitance ($C_{EXT} = 0$). If higher input source resistances are desired the master clock rate can be reduced to yield a longer settling time for the 64 cycle period.

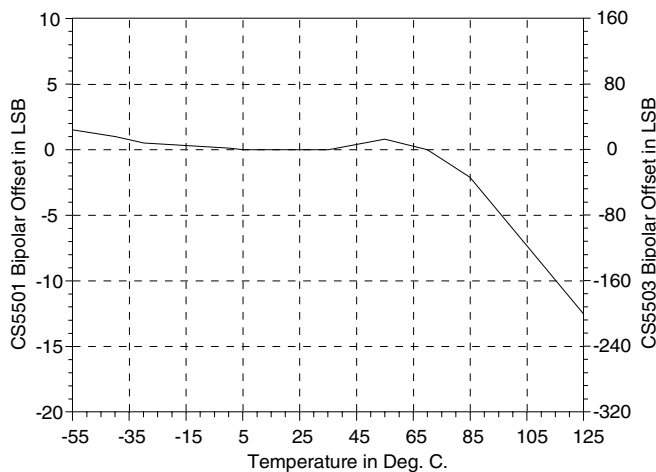

Figure 12. Typical Self-Cal Bipolar Offset vs. Temperature After Calibration at 25 °C

Analog Input Drift Considerations

The CS5501/CS5503 analog input uses chopper-stabilization techniques to minimize input offset

drift. Charge injection in the analog switches and leakage currents at the sampling node are the primary sources of offset voltage drift in the converter. Figure 12 indicates the typical offset drift due to temperature changes experienced after calibration at 25 °C. Drift is relatively flat up to about 75 °C. Above 75 °C leakage current becomes the dominant source of offset drift. Leakage currents approximately double with each 10 °C of temperature increase. Therefore the offset drift due to leakage current increases as the temperature increases. The value of the voltage on the sample capacitor is updated at a rate determined by the master clock, therefore the amount of offset drift which occurs will be proportional to the elapsed time between samples. In conclusion, the offset drift increases with temperature and is inversely proportional to the CLKIN rate. To minimize offset drift with increased temperature, higher CLKIN rates are desirable. At temperatures above 100 °C, a CLKIN rate above 1 MHz is recommended. The effects of offset drift due to temperature changes can be eliminated by recalibrating the CS5501/CS5503 whenever the temperature has changed.

Gain drift within the converter depends predominately upon the temperature tracking of internal capacitors. Gain drift is not affected by leakage currents, therefore gain drift is significantly less than comparable offset errors due to temperature increases. The typical gain drift over the specified temperature range is less than 2.5 LSBs for the CS5501 and less than 40 LSBs for the CS5503 .

Measurement errors due to offset drift or gain drift can be eliminated at any time by recalibrating the converter. Using the system calibration mode can also minimize offset and gain errors in the signal conditioning circuitry. The CS5501/CS5503 can be recalibrated at any temperature to remove the effects of these errors.

Linearity and differential non linearity are not significantly affected by temperature changes.

Filtering

At the system level, the digital filter in the CS5501/CS5503 can be modeled exactly like an analog filter with a few minor differences. Digital filtering resides *behind* the A/D conversion and can thus reject noise injected during the conversion process (i.e. power supply ripple, voltage reference noise, or noise in the ADC itself). Analog filtering cannot.

Also, since digital filtering resides behind the A/D converter, noise riding unfiltered on a near-full-scale input could potentially over-range the ADC. In contrast, analog filtering removes the noise before it ever reaches the converter. To address this issue, the CS5501/CS5503 each contain an analog modulator and digital filter which reserve headroom such that the device can process signals with 100mV "excursions" above full-scale and still output accurately converted and filtered data. Filtered input signals above full-scale still result in an output of all ones.

The digital filter's corner frequency occurs at $CLKIN/409,600$, where $CLKIN$ is the master clock frequency. With a 4.096MHz clock, the

filter corner is at 10Hz and the output register is updated at a 4kHz rate. $CLKIN$ frequency can be reduced with a proportional reduction in the filter corner frequency and in the update rate to the output register. A plot of the filter response is shown in the specification tables section of this data sheet.

Both the CS5501/CS5503 employ internal digital filtering which creates a 6-pole Gaussian relationship. With the corner frequency set at 10Hz for minimized settling time, the CS5501/CS5503 offer approximately 55dB rejection at 60Hz to signals coming into either the AIN or VREF pins. With a 5Hz cut-off, 60Hz rejection increases to more than 90dB.

The digital filter (rather than the analog modulator) dominates the converters' settling for step-function inputs. Figure 13 illustrates the settling characteristics of the filter. The vertical axis is normalized to the input step size. The horizontal axis is in filter cycles. With a full scale input step (2.5 V in unipolar mode) the output will exhibit an overshoot of about 0.25 LSB_{16} in the CS5501 and 4 LSB_{20} in the CS5503.

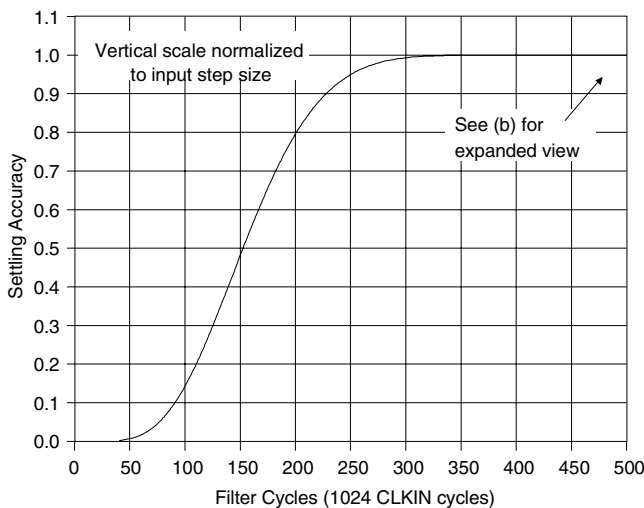

(a) Settling Time Due to Input Step Change

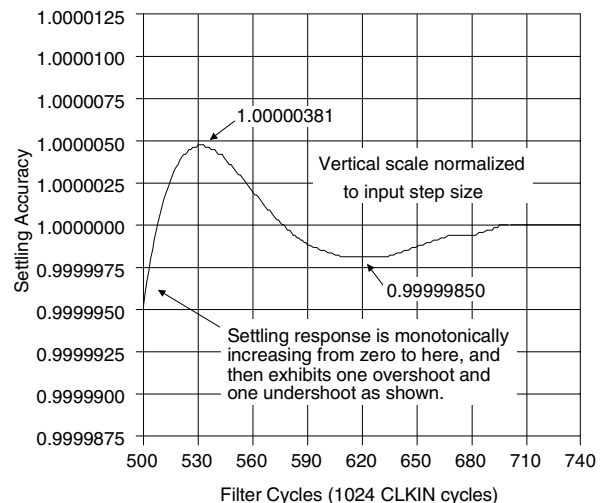

(b) Expanded Version of (a)

Anti-Alias Considerations

The digital filter in the CS5501/CS5503 does not provide rejection around integer multiples of the oversampling rate $[(N \cdot \text{CLKIN})/256]$, where $N = 1, 2, 3, \dots$. That is, with a 4.096 MHz master clock the noise on the analog input signal within the narrow ± 10 Hz bands around the 16 kHz, 32 kHz, 48 kHz, etc., passes unfiltered to the digital output. Most broadband noise will be very well filtered because the CS5501/CS5503 use a very high oversampling ratio of 800 (16 kHz: 2x10 Hz). Broadband noise is reduced by:

$$e_{out} = e_{in} \sqrt{2f_{-3dB}/f_s}$$

$$e_{out} = 0.035 e_{in}$$

where e_{in} and e_{out} are rms noise terms referred to the input. Since f_{-3dB} equals $\text{CLKIN}/409,600$ and f_s equals $\text{CLKIN}/256$, the digital filter reduces white, broadband noise by 96.5% independent of the CLKIN frequency. For example, a typical operational amplifier's 50 μV rms noise would be reduced to 1.75 μV rms (0.035 LSB's rms at the 16-bit level in the CS5501 and 0.4 LSB's rms at the 20-bit level in the CS5503).

Simple high frequency analog filtering in the signal conditioning circuitry can aid in removing energy at multiples of the sampling rate.

Bits of Output Accuracy	Filter Cycles	CLKIN Cycles
9	340	348,160
10	356	364,544
11	389	398,336
12	435	445,440
13	459	470,016
14	475	486,400
15	486	497,664
16	495	506,880
17	500	512,000
18	504	516,096
19	506	518,144
20	507	519,168

Table 5. Settling Time of the 6 Pole Low Pass Filter in the CS5501 to 1/2 LSB Accuracy with a Full Scale Step Input

Post Filtering

Post filtering is useful to enhance the noise performance of the CS5503. With a constant input voltage the output codes from the CS5503 will exhibit some variation due to noise. The CS5503 has typically 1.6 LSB₂₀ rms noise in its output codes. Additional variation in the output codes can arise due to noise from the input signal source and from the voltage reference. Post filtering (digital averaging) will be necessary to achieve less than 1 LSB p-p noise at the 20-bit level. The CS5503 has peak noise less than the 18-bit level without additional filtering if care is exercised in the design of the voltage reference and the input signal condition circuitry. Noise in the bandwidth from dc to 10 Hz on both the AIN and VREF inputs should be minimized to ensure maximum performance. As the amount of noise will be highly system dependent, a specific recommendation for post filtering for all applications cannot be stated. The following guidelines are helpful. Realize that the digital filter in the CS5503, like any other low pass filter, acts as an information storage unit. The filter retains past information for a period of time even after the input signal has changed. The implication of this is that immediately sequential 20-bit updates to the serial port contain highly correlated information. To most efficiently post filter the CS5503 output data, uncorrelated samples should be used. Samples which have sufficiently reduced correlation can be obtained if the CS5503 is allowed to execute 200 filter cycles between each subsequent data word collected for post filtering.

The character of the noise in the data will influence the post filtering requirements. As a general rule, averaging N uncorrelated data samples will reduce noise by $1/\sqrt{N}$. While this rule assumes that the noise is white (which is true for the CS5503 but not true for all real system signals between dc and 10Hz), it does offer a starting point for developing a post filtering algorithm for removing the noise from the data. The algorithm

will have to be empirically tested to see if it meets the system requirements. It is recommended that any testing include input signals across the entire input span of the converter as the signal level will affect the amount of noise from the reference input which is transferred to the output data.

Voltage Reference

The voltage reference applied to the VREF input pin defines the analog input range of the CS5501/CS5503. The preferred reference is 2.5V, but the device can typically accept references from 1V to 3V. Input signals which exceed 2.6V (+ or -) can cause some linearity degradation. Figure 14 illustrates the voltage reference connections to the CS5501/CS5503.

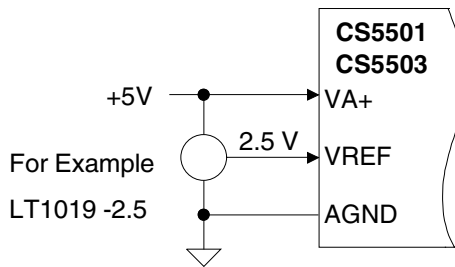

Figure 14. Voltage Reference Connections

The circuitry inside the VREF pin is identical to that as seen at the AIN pin. The sample capacitor (see Figure 12) requires packets of charge from the external reference just as the AIN pin does. Therefore the same settling time requirements apply. Most reference IC's can handle this dynamic load requirement without inducing errors. They exhibit sufficiently low output impedance and wide enough bandwidth to settle to within the necessary accuracy in the requisite 64 CLKIN cycles.

Noise from the reference is filtered by the digital filter, but the reference should be chosen to minimize noise below 10 Hz. The CS5501/CS5503 typically exhibit 0.1 LSB rms and 1.6 LSB rms noise respectively. This specification assumes a clean reference voltage. Many monolithic

band-gap references are available which can supply 2.5 V for use with the CS5501/CS5503. Many of these devices are not specified for noise, especially in the 0.1 to 10 Hz bandwidth. Some of these devices may exhibit noise characteristics which degrade the performance of the CS5501/CS5503.

Power Supplies And Grounding

The CS5501/CS5503 use the analog ground connection, AGND, as a measurement reference node. It carries no power supply current. The AGND pin should be used as the reference node for both the analog input signal and for the reference voltage which is input into the VREF pin.

The analog and digital supply inputs are pinned out separately to minimize coupling between the analog and digital sections of the chip. To achieve maximum performance, all four supplies for the CS5501/CS5503 should be decoupled to their respective grounds using 0.1 μ F capacitors. This is illustrated in the System Connection Diagram, Figure 15, at the beginning of this data sheet.

As CMOS devices, the CS5501/CS5503 require that the positive analog supply voltage always be greater than or equal to the positive digital supply voltage. If the voltage on the positive digital supply should ever become greater than the voltage on the positive analog supply, diode junctions in the CMOS structure which are normally reverse-biased will become forward-biased. This may cause the part to draw high currents and experience permanent damage. The connections shown in Figure 15 eliminate this possibility.

To ensure reliable operation, be certain that power is applied to the part before signals at AIN, VREF, or the logic input pins are present. If current is supplied into any pin before the chip is powered-up, latch-up may result. As a system, it is desirable to power the CS5501/CS5503, the volt-

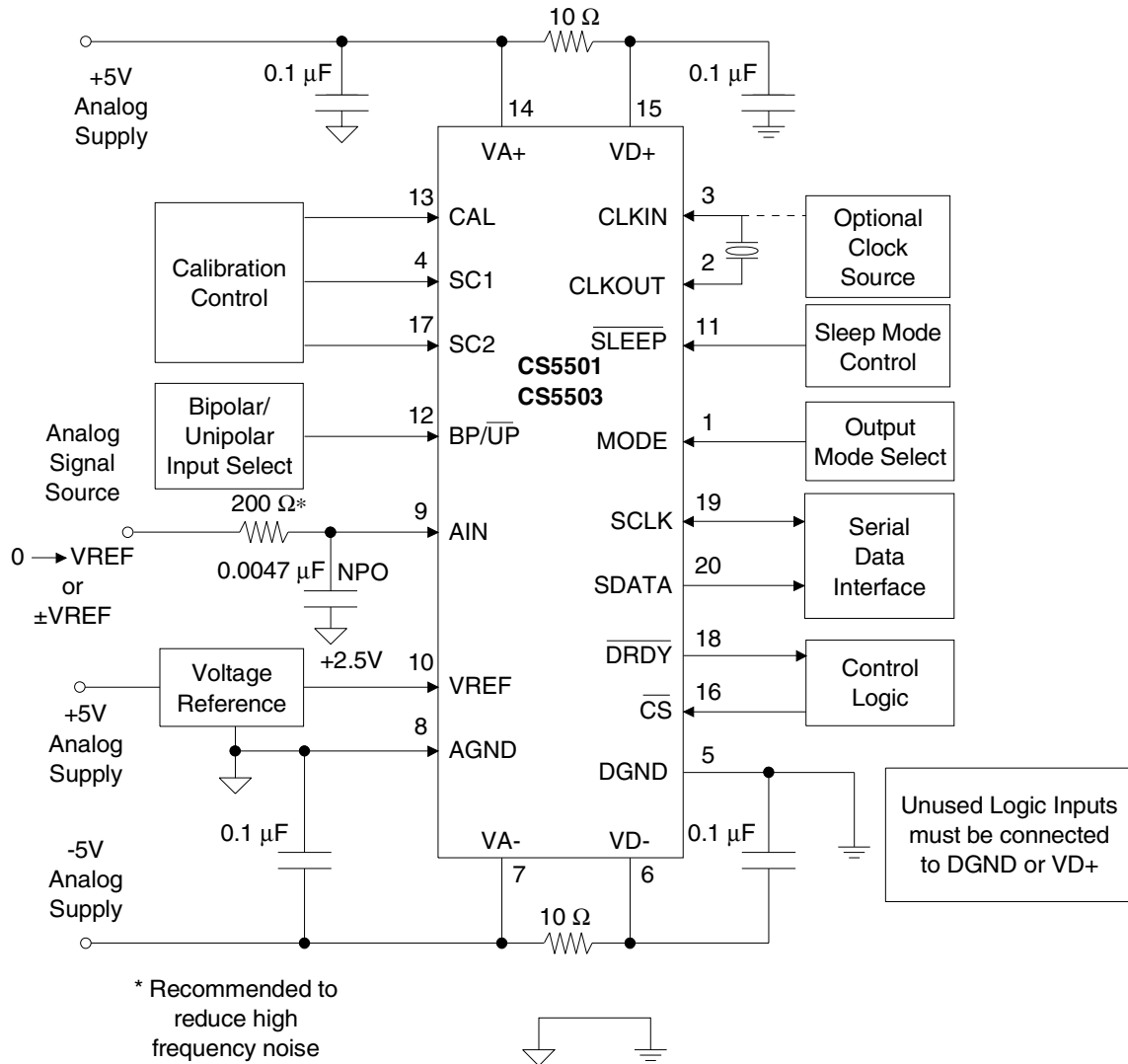

Figure 15. Typical Connection Diagram

age reference, and the analog signal conditioning circuitry from the same primary source. If separate supplies are used, it is recommended that the CS5501/CS5503 be powered up first. If a common power source is used for the analog signal conditioning circuitry as well as the A/D converter, this power source should be applied before application of power to the digital logic supply.

The CS5501/CS5503 exhibit good power supply rejection for frequencies within the passband (dc to 10 Hz). Any small offset or gain error caused by long term drift of the power supplies can be

removed by recalibration. Above 10 Hz the digital filter will provide additional rejection. When the benefits of the digital filter are added to the regular power supply rejection the effects of line frequency variations (60 Hz) on the power supplies will be reduced greater than 120 dB. If the supply voltages for the CS5501/CS5503 are generated with a dc-dc converter the operating frequency of the dc-dc converter should not operate at the sampling frequency of the CS5501/CS5503 or at integer multiples thereof. At these frequencies the digital filter will not aid in power supply rejection. See *Anti-Alias Considerations* section of this data sheet.

The recommended system connection diagram for the CS5501/CS5503 is illustrated in Figure 15. Note that any digital logic inputs which are to be unused should be tied to either DGND or the VD+ as appropriate. They should not be left floating; nor should they be tied to some other logic supply voltage in the system.

Power-up and Initialization

Upon power-up, a calibration cycle must be initiated at the CAL pin to insure a consistent starting condition and to initially calibrate the device. The CAL pin must be strobed high for a minimum of 4 clock cycles. The falling edge will initiate a calibration cycle. A simple power-on reset circuit can be built using a resistor and capacitor (see Figure 16). The resistor and capacitor values should allow for clock or oscillator startup time, and the voltage reference stabilization time.

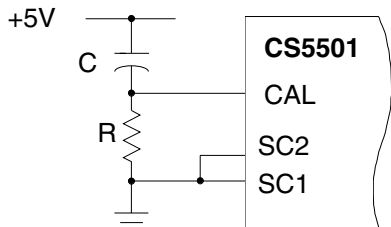

Figure 16. Power-On Reset Circuitry (Self-Calibration Only)

Due to the devices' low power dissipation and low temperature drift, no warm-up time is required to accommodate any self-heating effects.

Sleep Mode

The CS5501/CS5503 include a sleep mode ($\overline{\text{SLEEP}} = \text{DGND}$) which shuts down the internal analog and digital circuitry reducing power consumption to less than 10 μW . All calibration coefficients are retained in memory such that no time is required after "awakening" for recalibration. Still, the CS5501/CS5503 will require time for the digital filter to settle before an accurate

reading will occur after a rising edge on $\overline{\text{SLEEP}}$ occurs.

Battery Backed-up Calibrations

The CS5501/CS5503 use SRAM to store calibration information. The contents of the SRAM will be lost whenever power is removed from the chip. Figure 17 shows a battery back-up scheme that can be used to retain the calibration memory during system down time and/or protect it against intermittent power loss. Note that upon loss of power, the SLEEP input goes low, reducing power consumption to just 10 μW . Lithium cells of 3.6 V are available which average 1750 mA-hours before they drop below the typical 2 V memory-retention specification of the CS5501/CS5503.

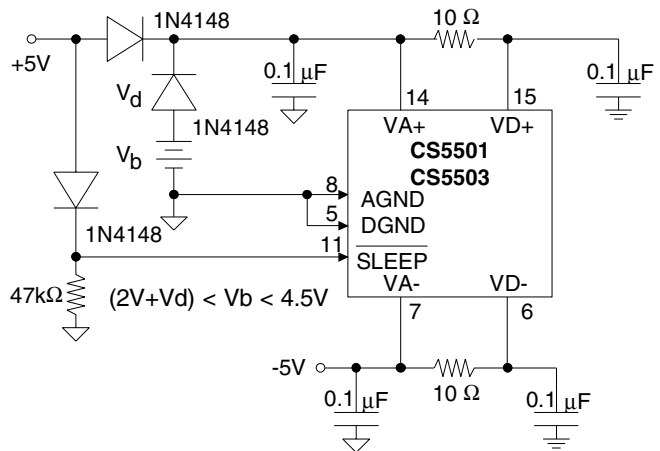

Figure 17. Example Calibration Memory Battery Back-Up Circuit

When $\overline{\text{SLEEP}}$ is active ($\overline{\text{SLEEP}} = \text{DGND}$), both VD+ and VA+ must remain powered to no less than 2 V to retain calibration memory. The VD- and VA- voltages can be reduced to 0 V but must not be allowed to go above ground potential. The negative supply must exhibit low source impedance in the powered-down state as the current into the VA+ pin flows out the VA- pin. (AGND is only a reference node. No power supply current flows in or out of AGND.) Care should be taken

to ensure that logic inputs are maintained at either VD+ or DGND potential when SLEEP is low.

Note that battery life could be shortened if the +5 V supply drops slowly during power-down. As the supply drops below the battery voltage but not yet below the logic threshold of the SLEEP pin, the battery will be supplying the CS5501/CS5503 at full power (typically 3 mA). Faster transitions at SLEEP can be triggered using a resistive divider or a simple resistor network to generate the SLEEP input from the +5 V supply.

Output Loading Considerations

To maximize performance of the CS5501/ CS5503, the output drive currents from the digital output lines should be minimized.

PIN DESCRIPTIONS

SERIAL INTERFACE MODE SELECT	MODE	1	20	SDATA	SERIAL DATA OUTPUT
CLOCK OUT	CLKOUT	2	19	SCLK	SERIAL CLOCK INPUT/OUTPUT
CLOCK IN	CLKIN	3	18	DRDY	DATA READY
SYSTEM CALIBRATION 1	SC1	4	17	SC2	SYSTEM CALIBRATION 2
DIGITAL GROUND	DGND	5	16	CS	CHIP SELECT
NEGATIVE DIGITAL POWER	VD-	6	15	VD+	POSITIVE DIGITAL POWER
NEGATIVE ANALOG POWER	VA-	7	14	VA+	POSITIVE ANALOG POWER
ANALOG GROUND	AGND	8	13	CAL	CALIBRATE
ANALOG IN	AIN	9	12	BP/UP	BIPOLAR/UNIPOLAR SELECT
VOLTAGE REFERENCE	VREF	10	11	SLEEP	SLEEP

* Pinout applies to both DIP and SOIC packages

Clock Generator

CLKIN; CLKOUT -Clock In; Clock Out, Pins 3 and 2.

A gate inside the CS5501/CS5503 is connected to these pins and can be used with a crystal or ceramic resonator to provide the master clock for the device. Alternatively, an external (CMOS compatible) clock can be input to the CLKIN pin as the master clock for the device. When not in SLEEP mode, a master clock (CLKIN) should be present at all times.

Serial Output I/O

MODE -Serial Interface Mode Select, Pin 1.

Selects the operating mode of the serial port. If tied to VD- (-5V), the CS5501 will operate in the UART-compatible AC mode for Asynchronous Communication. The SCLK pin will operate as an *input* to set the data rate, and data will transmit *formatted* with one start and two stop bits. If MODE is tied to DGND, the CS5501/CS5503 will operate in the SEC (Synchronous External-Clocking) mode, with the SCLK pin operating as an *input* and the output appearing MSB-first. If MODE is tied to VD+ (+5V), the CS5501/CS5503 will operate in its SSC (Synchronous Self-Clocking) mode, with SCLK providing a serial clock *output* of CLKIN/4 (25% duty-cycle).

DRDY -Data Ready, Pin 18.

DRDY goes low every 1024 cycles of CLKIN to indicate that new data has been placed in the output port. DRDY goes high when all the serial port data is clocked out, when the serial port is being updated with new data, when a calibration is in progress, or when SLEEP is low.

CS -Chip Select, Pin 16.

An input which can be enabled by an external device to gain control over the serial port of the CS5501/CS5503.

SDATA -Serial Data Output, Pin 20.

Data from the serial port will be output from this pin at a rate determined by SCLK and in a format determined by the MODE pin. It furnishes a high impedance output state when not transmitting data.

SCLK -Serial Clock Input/Output, Pin 19.

A clock signal at this pin determines the output rate of the data from the SDATA pin. The MODE pin determines whether the SCLK signal is an input or output. SCLK may provide a high impedance output when data is not being output from the SDATA pin.

Calibration Control Inputs

SC1; SC2 -System Calibration 1 and 2, Pins 4 and 17.

Control inputs to the CS5501/CS5503's calibration microcontroller for calibration. The state of SC1 and SC2 determine which of the calibration modes is selected for operation (see Table 2).

BP/UP -Bipolar/Unipolar Select, Pin 12.

Determines whether the CS5501/CS5503 will be calibrated to measure bipolar ($\overline{\text{BP/UP}} = \text{VD+}$) or unipolar ($\overline{\text{BP/UP}} = \text{DGND}$) input signals. Recalibration is necessary whenever the state of BP/UP is changed.

CAL -Calibrate, Pin 13.

If brought high for 4 clock cycles or more, the CS5501/CS5503 will reset and upon returning low a full calibration cycle will begin. The state of SC1, SC2, and BP/UP when CAL is brought low determines the type and length of calibration cycle initiated (see Table 2). Also, a single CAL signal can be used to strobe the CAL pins high on several CS5501/CS5503's to synchronize their operation. Any spurious glitch on this pin may inadvertently place the chip in Calibration mode.

Other Control Input

SLEEP -Sleep, Pin 11.

When brought low, the CS5501/CS5503 will enter a low-power state. When brought high again, the CS5501/CS5503 will resume operation without the need to recalibrate. After SLEEP goes high again, the device's output will settle to within $+0.0007\%$ of the analog input value within $1.3/f_{-3\text{dB}}$, where $f_{-3\text{dB}}$ is the passband frequency. The SLEEP input can also be used to synchronize sampling and the output updates of several CS5501/CS5503's.

Analog Inputs

VREF -Voltage Reference, Pin 10.

Analog reference voltage input.

AIN -Analog Input, Pin 9.

Power Supply Connections

VD+ -Positive Digital Power, Pin 15.

Positive digital supply voltage. Nominally +5 volts.

VD- -Negative Digital Power, Pin 6.

Negative digital supply voltage. Nominally -5 volts.

DGND -Digital Ground, Pin 5.

Digital ground.

VA+ -Positive Analog Power, Pin 14.

Positive analog supply voltage. Nominally +5 volts.

VA- -Negative Analog Power, Pin 7.

Negative analog supply voltage. Nominally -5 volts.

AGND -Analog Ground, Pin 8.

Analog ground.

SPECIFICATION DEFINITIONS

Linearity Error

The deviation of a code from a straight line which connects the two endpoints of the A/D Converter transfer function. One endpoint is located 1/2 LSB below the first code transition and the other endpoint is located 1/2 LSB beyond the code transition to all ones. Units in percent of full-scale.

Differential Linearity

The deviation of a code's width from the ideal width. Units in LSB's.

Full-Scale Error

The deviation of the last code transition from the ideal (VREF-3/2 LSB's). Units in LSBs.

Unipolar Offset

The deviation of the first code transition from the ideal (1/2 LSB above AGND) when in unipolar mode (BP/UP low). Units in LSBs.

Bipolar Offset

The deviation of the mid-scale transition (011...111 to 100...000) from the ideal (1/2 LSB below AGND) when in bipolar mode (BP/UP high). Units in LSBs.

Bipolar Negative Full-Scale Error

The deviation of the first code transition from the ideal when in bipolar mode (BP/UP high). The Ideal is defined as lying on a straight line which passes through the final and mid-scale code transitions. Units in LSBs.

Positive Full-Scale Input Overrange

The absolute maximum positive voltage allowed for either accurate system calibration or accurate conversions. Units in volts.

Negative Full-Scale Input Overrange

The absolute maximum negative voltage allowed for either accurate system calibration or accurate conversions. Units in volts.

Offset Calibration Range

The CS5501/CS5503 calibrate their offset to the voltage applied to the AIN pin when in system calibration mode. The first code transition defines Unipolar Offset when BP/UP is low and the mid-scale transition defines Bipolar Offset when BP/UP is high. The Offset Calibration Range specification indicates the range of voltages applied to AIN that the CS5501 or CS5503 can accept and still calibrate offset accurately. Units in volts.

Input Span

The voltages applied to the AIN pin in system-calibration schemes define the CS5501/CS5503 analog input range. The Input Span specification indicates the minimum and maximum input spans from zero-scale to full-scale in unipolar, or from positive full scale to negative full scale in bipolar, that the CS5501/CS5503 can accept and still calibrate gain accurately. Units in volts.

ORDERING INFORMATION

Model	Package	Resolution	Throughput	Linearity	Temperature
CS5501-BP	20-pin Plastic DIP	16 Bits	4 kSps	0.0015	-40 to +85 °C
CS5501-BS	20-pin SOIC				
CS5501-BSZ (lead free)					
CS5503-BP	20-pin Plastic DIP	20 Bits	4 kSps	0.0015	-40 to +85 °C
CS5503-BS	20-pin SOIC				
CS5503-BSZ (lead free)					

ENVIRONMENTAL, MANUFACTURING, & HANDLING INFORMATION

Model	Peak Reflow Temp	MSL Rating*	Maximum Floor Life
CS5501-BP	260 °C	1	No Limit
CS5501-BS	240 °C	2	365 Days
CS5501-BSZ (lead free)	260 °C	3	7 Days
CS5503-BP	260 °C	1	No Limit
CS5503-BS	240 °C	2	365 Days
CS5503-BSZ (lead free)	260 °C	3	7 Days

* MSL (Moisture Sensitivity Level) as specified by IPC/JEDEC J-STD-020.

APPENDIX A: APPLICATIONS

Parallel Interface

Figures A1 and A2 show two serial-to-parallel conversion circuits for interfacing the CS5501 in its SSC mode to 16- and 8-bit systems respectively. Each circuit includes an optional 74HCT74 flip-flop to latch $\overline{\text{DRDY}}$ and generate a level-sensitive interrupt.

Both circuits require that the parallel read process be synchronized to the CS5501's operation. That is, the system must not try to enable the registers' parallel output while they are accepting serial data from the CS5501. The CS5501's $\overline{\text{DRDY}}$ falls just prior to serial data transmission

and returns high as the last bit shifts out. Therefore, the $\overline{\text{DRDY}}$ pin can be polled for a rising transition directly, or it can be latched as a level-sensitive interrupt.

With the $\overline{\text{CS}}$ input tied low the CS5501 will shift out every available sample (4kHz word rate with a 4MHz master clock). Lower output rates (and interrupt rates) can be generated by dividing down the $\overline{\text{DRDY}}$ output and applying it to $\overline{\text{CS}}$.

Totally asynchronous interfaces can be created using a *Shift Data* control signal from the system which enables the CS5501's $\overline{\text{CS}}$ input and/or the shift registers' S1 inputs. The $\overline{\text{DRDY}}$ output can then be used to disable serial data transmission once an output word has been fully registered.

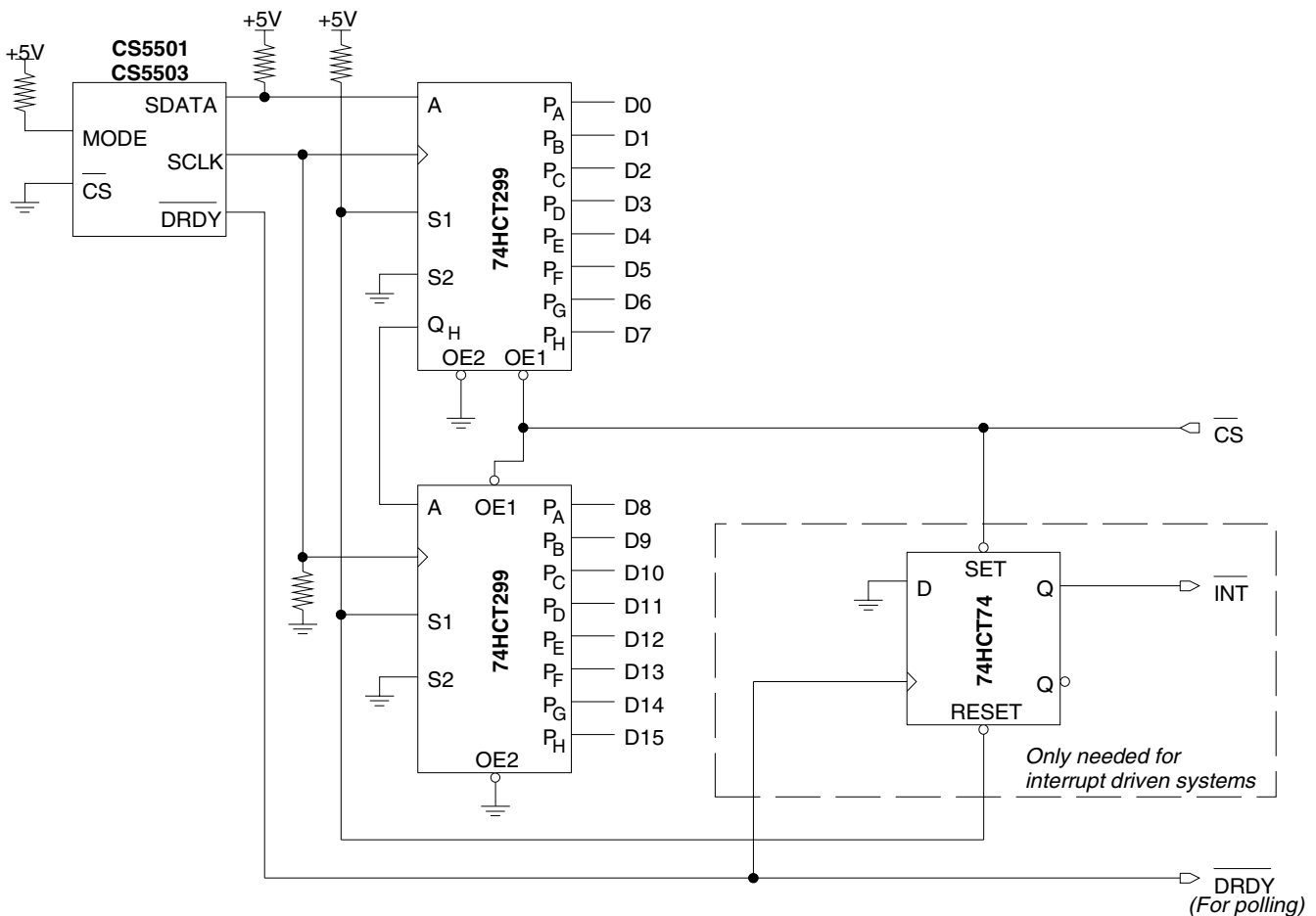

Figure A1. 16-bit Parallel Interface

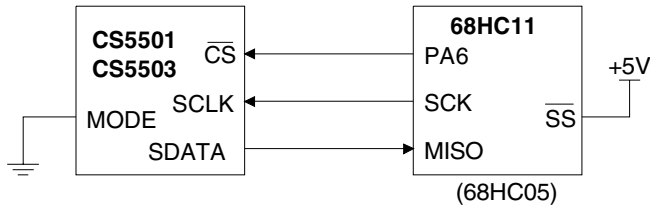

Figure A3. 68HC11/CS5501 Serial Interface

Notes:

1. CS5501 in *Synchronous External Clocking* mode.
2. Using 68HC11's SPI port. (Can use SCI and CS5501's Asynchronous mode.)
3. Maximum bit rate is 1.05 Mbps.

Assumptions:

1. PA6 used as \overline{CS} .
2. 68HC11 in single-chip mode.
3. Receive data via polling.
4. Normal equates for peripheral registers.
5. Data returned in register D.

Initial Code:

```

SPINIT: PSHA                ; Store temporary copy of A
        LDAA  #0x1xxxxxx    ; Bit 6 = 1, all others are don't cares
        STAA PORTA         ; CS = 1, inactive; deselect CS5501
        LDAA  #$10          ;
        STAA SPCR          ; Disable serial port
        LDAA  #0xx0110xx    ; SS-input, SCK-output,
                                ; MOSI-output, MISO-input
        STAA DDRD          ; Data direction register for port D
        LDAA  #$50          ; Enable serial port, CMOS outputs,
        STAA SPCR          ; master, highest clock rate (int. clk/2)
        LDAA  SPSR          ;
        LDAA  SPDR          ; Bogus read to clr port and SPIF flag
        PULA                ; Restore A
        RTS                 ;
    
```

Code to get word of data:

```

SP_IN:  LDAA  #0xxxxxx      ;
        STAA PORTA         ; CS = 0, active; select CS5501
        STAA SPDR          ; Put data in serial port to start clk
WAIT1:  LDAA  SPSR          ; Get port status
        BPL  WAIT1         ; If SPIF (MSB) 0, no data yet, wait
        LDAA  SPDR          ; Put most significant byte in A
        STAA SPDR          ; Start serial port for second byte
WAIT2:  LDAB  SPSR          ; Get port status
        BPL  WAIT2         ; If SPIF (MSB) 0, no data yet, wait
        LDAB  #0x1xxxxxx   ;
        STAB PORTA         ; CS = 1, inactive; deselect CS5501
        LDAB  SPDR          ; Put least significant byte in B
        RTS                 ;
    
```

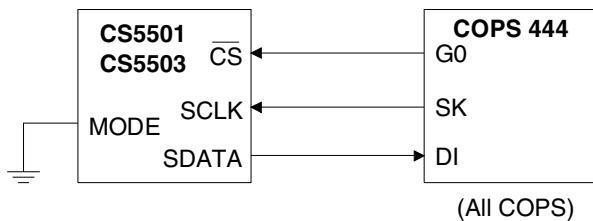

Figure A4. COPS/CS5501 Interface

Notes:

1. CS5501 in *Synchronous External Clocking* mode.
2. COPS 444 max baud = 62.5 kbps. (Others = 500 kbps)
3. See timing diagram for detailed timing.

Assumptions:

1. G0 used as \overline{CS} .
2. Register 0 (upper four nibbles) used to store 16-bit word.

Initial Code:

```

SPINIT: OGI  15            ; CS = 1, inactive; deselect CS5501
        RC                ; Reset carry, used in next
        XAS               ; instruction to turn SK off
    
```

Code to get word of data:

```

SP_IN:  LBI  0,12          ; Point to start of data
        SC                ; storage location
                                ; Set carry - enables SK in
                                ; XAS instruction
        OGI  14            ; CS = 0, active; select CS5501
        LEI  0            ; Shift register mode, S0 = 0
        XAS               ; Start clocking serial port
        NOP               ;
        NOP               ; Wait for (first) M.S. nibble
GETNIB: NOP               ;
        XAS               ; Get nibble of data from SIO
        XIS               ; Put nibble in memory, inc. pointer,
        JP  GETNIB        ; if overflow, jump around this inst.
        RC                ; Reset carry - disables SK in XAS
                                ; instruction
        XAS               ; Bogus read - stops SK
        OGI  15            ; CS = 1, inactive; deselect CS5501
        RET               ;
    
```

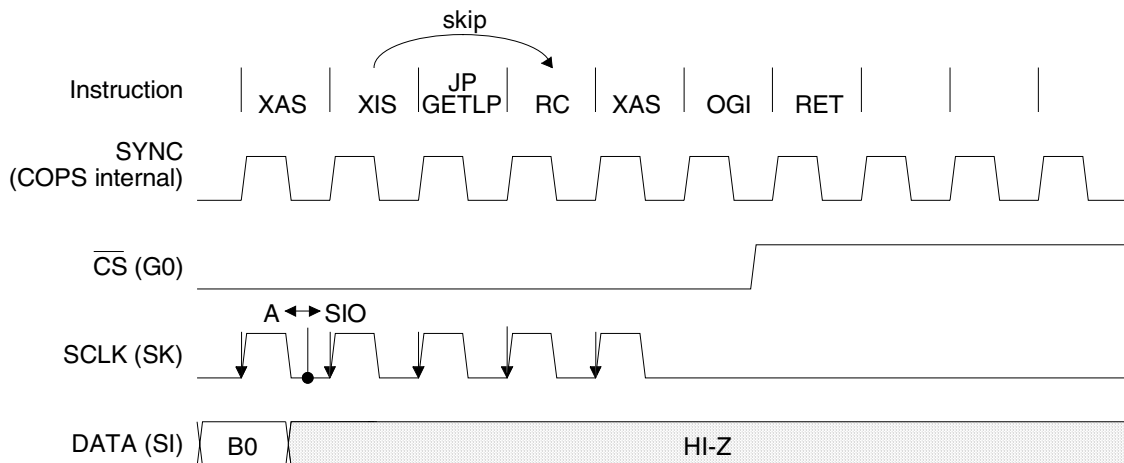
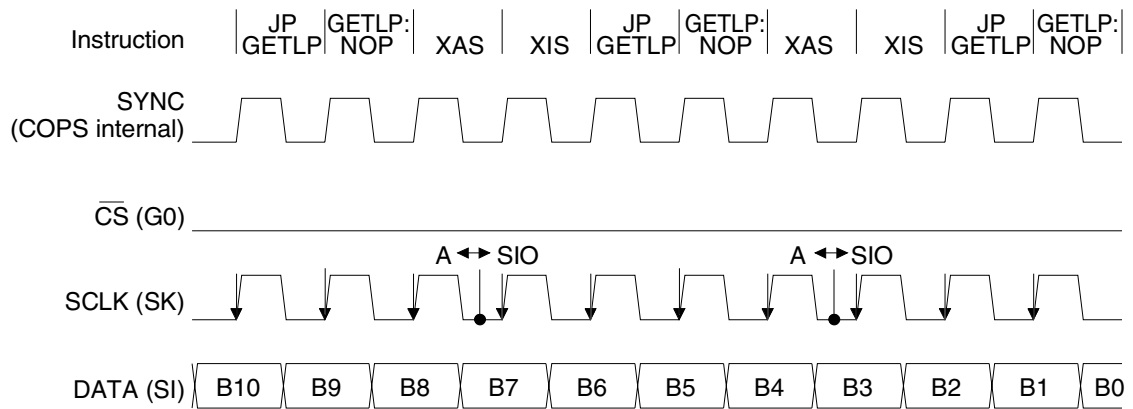
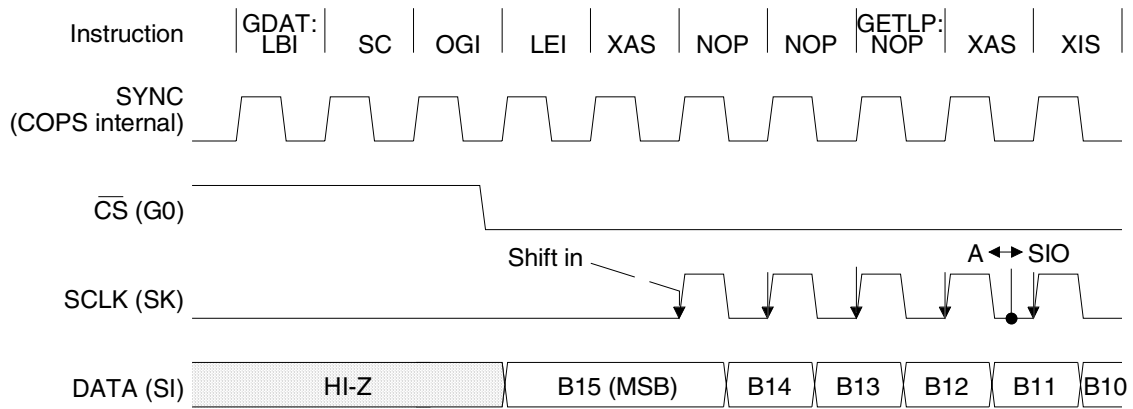

Figure A5. Serial Timing Example - COPS

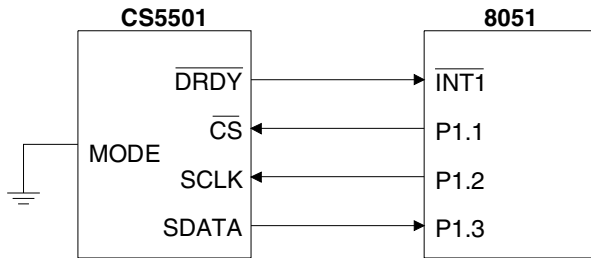

Figure A6. MCS51 (8051) /CS5501 Serial Interface

Notes:

1. CS5501 in Synchronous External Clocking mode.
2. Interrupt driven I/O on 8051 (For polling, connect DRDY to another port pin).

Assumptions:

1. INT1 external interrupt used.
2. Register bank 1, R6, R7 used to store data word, R7 MSbyte.
3. EA enabled elsewhere.

Initial Code:

```

CS EQU P1.1
SCLK EQU P1.2
DATA EQU P1.3
SPINIT: CLR EX1 ; Disable INT1
        SETB IT1 ; Set INT1 for falling edge triggered
        SETB DATA ; Set DATA to be input pin
        SETB CS ; CS = 1; deselect CS5501
        CLR SCLK ; SCLK low
        SETB EX1 ; Enable INT1 interrupt
    
```

Code to get word of data:

```

ORG 0003H
LJMP GETWD ; Interrupt vector
GETWD: PUSH PSW ; Save temp. copy
      PUSH A ; Save temp. copy
      MOV PSW,#08 ; Set register bank 1 active
      MOV R6,#8 ; number of bits in a byte
      CLR CS ; CS = 0; select CS5501
MSBYTE:SETB SCLK ; Toggle SCLK high
      MOV C,DATA ; Put bit of data into carry bit
      CLR SCLK ; Toggle SCLK low; next data bit
      RLC A ; Shift DATA bit into A register
      DJNZ R6,MSBYTE ; Dec. R6, if not 0, get another bit
      MOV R7,A ; Put MSbyte into R7
      MOV R6,#8 ; Reset R6 to number of bits in byte
LSBYTE:SETB SCLK ; Toggle SCLK high
      MOV C,DATA ; Put bit of data into carry bit
      CLR SCLK ; Toggle SCLK low; next data bit
      RLC A ; Shift DATA bit into A register
      DJNZ R6,LSBYTE ; Dec. R6, if not 0, get another bit
      MOV R6,A ; Put LSbyte into R6
      SETB CS ; CS = 1; deselect CS5501
      POP A ; Restore original value
      POP PSW ; Restore original value
      RETI
    
```

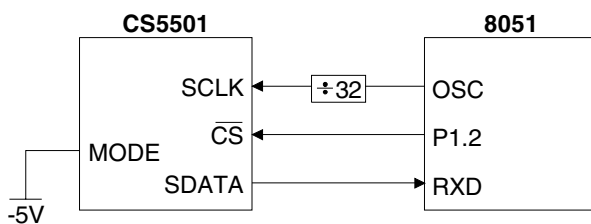

Figure A7. MCS51 (8051) /CS5501 UART Interface

Notes:

1. CS5501 in Asynchronous (UART-like) mode.
2. 8051 in mode 2, with OSC = 12 MHz, max baud = 375 kbps.

Assumptions:

1. P1.2 (port 1, bit 2) used as CS.
2. Using serial port mode 2, Baud rate = OSC/32.

(Assumptions cont.)

3. Word received put in A (ACC) and B registers, A = MSbyte.
4. No error checking done.
5. Equates used for peripheral names.

Initial Code:

```

SPINIT: SETB SMOD ; Set SMOD = 1, baud = OSC/32
        SETB P1.2 ; CS = 1, inactive
        MOV SCON,#1001000B ; Enable serial port mode 2,
        ; receiver enabled, transmitter disabled
        CLR ES ; Disable serial port interrupts (polling)
        RET ;
    
```

Code to get word of data:

```

SP_IN: CLR P1.2 ; CS = 0, active; select CS5501
      JNB RI,$ ; Wait for first byte
      CLR RI ;
      MOV A,SBUF ; Put most significant byte in A
      JNB RI,$ ; wait for second byte
      CLR RI ;
      MOV B,SBUF ; Put least significant byte in B
      SETB P1.2 ; CS = 1, inactive; deselect CS5501
      RET ;
    
```

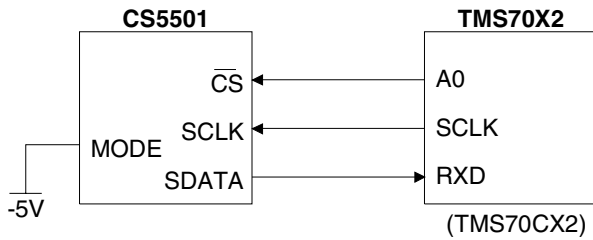

Figure A8. TMS70X2/CS5501 Serial Interface

Notes:

1. CS5501 in Asynchronous (UART-like) mode.
2. TMS70X2 in Isosynchronous mode.
3. TMS70X2 with 8 MHz master clock has max baud = 1.0 Mbps.

Assumptions:

1. A0 used as \overline{CS} .
2. Receive data via polling.
3. Word received put in A and B upon return, A = MS byte.
4. No error checking done.
5. Normal equates for peripheral registers.

Initial Code:

```

SPINIT: DINT      ;
        MOVP %1,ADDR ; A port is output
        MOVP %1,APORT ; A0 = 1, (CS is inactive)
        MOVP %0,P17 ;
        MOVP %>10,SCTLO ; Resets port errors
        MOVP %?x1x01101,SMODE ; Set port for Isosync,
        MOVP %?00x1110x,SCTLO ; 8 bits, no parity
        MOVP %07,T3DATA ; Max baud rate
        MOVP %?01000000,SCTL1 ; No multiprocessor;
        ; prescale = 4
        MOVP %0,IOCNT1 ; Disable INT4 - will poll port
        PUSH A ; Store original
        MOVP RXBUF,A ; Bogus read to clr receiver port flag
        POP A ; Restore original
        EINT ;
        RET ;
    
```

Code to get word of data:

```

SP_IN: MOVP %0,APORT ;  $\overline{CS}$  active, select CS5501
WAIT1 BTJZP %2,SSTAT,WAIT1 ; Wait to receive first byte
      MOVP RXBUF,A ; Put most significant byte in reg. A
WAIT2 BTJZP %2,SSTAT,WAIT2 ; Wait to receive second byte
      MOVP RXBUF,B ; Put least significant byte in reg. B
      MOVP %1,APORT ; CS inactive, deselect CS5501
      RET ;
    
```

Contacting Cirrus Logic Support

For all product questions and inquiries contact a Cirrus Logic Sales Representative.

To find the one nearest to you go to www.cirrus.com

IMPORTANT NOTICE

Cirrus Logic, Inc. and its subsidiaries (“Cirrus”) believe that the information contained in this document is accurate and reliable. However, the information is subject to change without notice and is provided “AS IS” without warranty of any kind (express or implied). Customers are advised to obtain the latest version of relevant information to verify, before placing orders, that information being relied on is current and complete. All products are sold subject to the terms and conditions of sale supplier at the time of order acknowledgment, including those pertaining to warranty, indemnification, and limitation of liability. No responsibility is assumed by Cirrus for the use of this information, including use of this information as the basis for manufacture or sale of any items, or for infringement of patents or other rights of third parties. This document is the property of Cirrus and by furnishing this information, Cirrus grants no license, express or implied under any patents, mask work rights, copyrights, trademarks, trade secrets or other intellectual property rights. Cirrus owns the copyrights associated with the information contained herein and gives consent for copying to be made of the information only for use within your organization with respect to Cirrus integrated circuits or other products of Cirrus. This consent does not extend to other copying such as copying for general distribution, advertising or promotional purposes, or for creating any work for resale.

CERTAIN APPLICATIONS USING SEMICONDUCTOR PRODUCTS MAY INVOLVE POTENTIAL RISKS OF DEATH, PERSONAL INJURY, OR SEVERE PROPERTY OR ENVIRONMENTAL DAMAGE (“CRITICAL APPLICATIONS”). CIRRUS PRODUCTS ARE NOT DESIGNED, AUTHORIZED OR WARRANTED FOR USE IN AIRCRAFT SYSTEMS, MILITARY APPLICATIONS, PRODUCTS SURGICALLY IMPLANTED INTO THE BODY, AUTOMOTIVE SAFETY OR SECURITY DEVICES, LIFE SUPPORT PRODUCTS OR OTHER CRITICAL APPLICATIONS. INCLUSION OF CIRRUS PRODUCTS IN SUCH APPLICATIONS IS UNDERSTOOD TO BE FULLY AT THE CUSTOMER’S RISK AND CIRRUS DISCLAIMS AND MAKES NO WARRANTY, EXPRESS, STATUTORY OR IMPLIED, INCLUDING THE IMPLIED WARRANTIES OF MERCHANTABILITY AND FITNESS FOR PARTICULAR PURPOSE, WITH REGARD TO ANY CIRRUS PRODUCT THAT IS USED IN SUCH A MANNER. IF THE CUSTOMER OR CUSTOMER’S CUSTOMER USES OR PERMITS THE USE OF CIRRUS PRODUCTS IN CRITICAL APPLICATIONS, CUSTOMER AGREES, BY SUCH USE, TO FULLY INDEMNIFY CIRRUS, ITS OFFICERS, DIRECTORS, EMPLOYEES, DISTRIBUTORS AND OTHER AGENTS FROM ANY AND ALL LIABILITY, INCLUDING ATTORNEYS’ FEES AND COSTS, THAT MAY RESULT FROM OR ARISE IN CONNECTION WITH THESE USES.

Cirrus Logic, Cirrus, and the Cirrus Logic logo designs are trademarks of Cirrus Logic, Inc. All other brand and product names in this document may be trademarks or service marks of their respective owners.

CS5501 & CS5503 Evaluation Boards

Features

- Operation with on-board clock generator, on-board crystal, or an off-board clock source.
- DIP switch selectable or micro port controllable:
 - Unipolar/Bipolar input range
 - Sleep Mode-All Cal Modes
- On-board Decimation Counter
- Multiple Data Output Interface Options:
 - RS-232 (CS5501)
 - Parallel Port (CS5501)
 - Micro Port (CS5501 & CS5503)

Description

The CDB5501/CDB5503 is an evaluation board designed for maximum flexibility when evaluating the CS5501/CS5503 A/D converters. The board can easily be configured to evaluate all the features of the CS5501/CS5503, including changes in master clock rate, calibration modes, output decimation rates, and interface modes.

The evaluation board interfaces with most microcontrollers and allows full control of the features of the CS5501 or CS5503. DIP switch selectable control is also available in the event a microcontroller is not used. The evaluation board also offers computer data interfaces including RS-232 and parallel port outputs for evaluating the CS5501.

All calibration modes are selectable including Self-Cal, System Offset Cal, and System Offset and System Gain Cal. A calibration can be initiated at any time by pressing the CAL pushbutton switch.

ORDERING INFORMATION

CDB5501	Evaluation Board
CDB5503	Evaluation Board

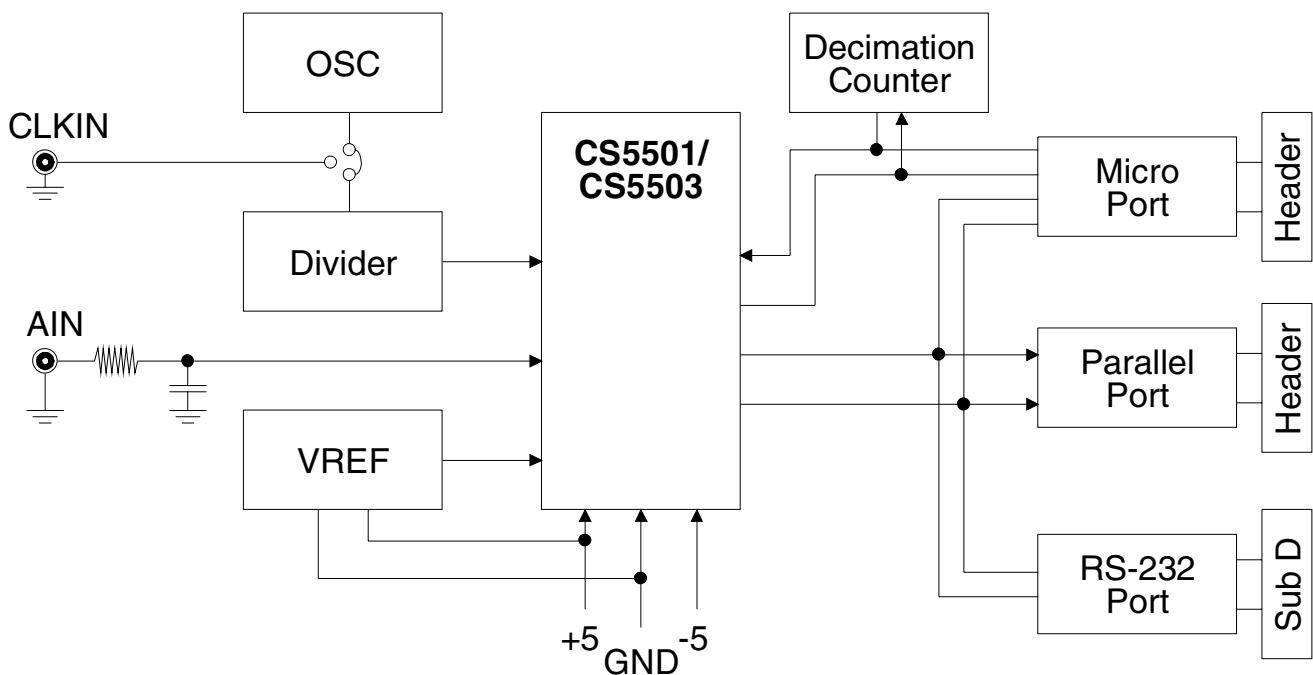

INTRODUCTION

The CDB5501/CDB5503 evaluation board provides maximum flexibility for controlling and interfacing to the CS5501/CS5503 A/D converters. The CS5501 or the CS5503 require a minimal amount of external circuitry. The devices can operate with a crystal (or ceramic resonator) and a voltage reference.

The evaluation board includes several clock source options, a 2.5 volt trimmable reference, and circuitry to support several data interface schemes. The board operates from +5 and -5 volt power supplies.

Evaluation Board Overview

The CDB5501/CDB5503 evaluation board includes extensive support circuitry to aid evaluation of the CS5501/CS5503. The support circuitry includes the following sections:

- 1) A clock generator which has an on-board oscillator and counter divider IC.
- 2) A 2.5 volt trimmable voltage reference.
- 3) A Decimation Counter.
- 4) A parallel output port (for CS5501 only).
- 5) An RS-232 interface (for CS5501 only).
- 6) A micro port (for CS5501 or CS5503).
- 7) DIP switch and CAL pushbutton.

Clock Generator

The CS5501/CS5503 can operate off its on-chip oscillator or an off-chip clock source. The evaluation board includes a 4.9152 MHz gate oscillator and counter-divider chain as the primary clock source for the CS5501/CS5503. The counter-divider outputs offer several jumper-selectable frequencies as clock inputs to the CS5501/CS5503. The 4.9152 MHz crystal frequency was chosen to allow the counter-divider chain to also provide the common serial data rates

(1200, 2400, 4800, etc.) when the CDB5501 evaluation board is configured to provide RS-232 data output. If a different operating frequency for the CS5501/CS5503 is desired, three options exist. First, a BNC input is provided to allow an external CMOS (+5V) compatible clock to be used. Second, the crystal (Y1) in the on-board gate oscillator can be changed. Or, third, the on-chip oscillator of the CS5501/CS5503 can be used with a crystal connected in the Y2 position.

2.5 Volt Reference

A 2.5 volt (LT1019CN8-2.5) reference is provided on the board. Potentiometer R9 allows the initial value of the reference to be accurately trimmed.

Decimation Counter

The CS5501/CS5503 updates its internal output register with a 16-bit word every 1024 clock cycles of the master clock. Each time the output register is updated the \overline{DRDY} line goes low. Although output data is updated at a high rate it may be desirable in certain applications to activate the \overline{CS} to read the data at a much lower rate. A decimation counter is provided on the board for this purpose. The counter reduces the rate at which the \overline{CS} line of the CS5501 is activated by only allowing \overline{CS} to occur at a sub-multiple of the \overline{DRDY} rate.

Parallel Output Port (for CS5501 only)

The output data from the CS5501/CS5503 is in serial form. Some applications may require the data to be read in parallel format. Therefore the evaluation board includes two 8-bit shift registers with three-state outputs. Data from the CS5501 is shifted into the registers and then read out in 16-bit parallel fashion. The parallel port comes set up for 16-bit parallel output but can be reconfigured to provide two 8-bit reads. The parallel port supports the CS5501 only, since the CS5503 outputs 20-bit words.

P-1	CLKIN Source to CS5501/CS5503
INT CLK	On-Board 4.9152 MHz OSC
EXT CLK	+5 CMOS CLKIN BNC

CLKIN Rate Selection (CLK/2ⁿ) with INT CLK on P1 selected.
CLK = 4.9152 MHz

P-2	CLKIN Rate
0	4.9152 MHz
1	2.4576 MHz
2	1.2288 MHz
3	614.4 kHz
4	307.2 kHz
5	153.6 kHz+
6	76.8 kHz+
7	38.4 kHz* +

* Exceeds CLKIN Specifications of CS5501.
+ Exceeds CLKIN specifications of CS5503.

Table 1. Clock Generator

case, the counter divides the input clock by 2^n where $n = 0, 1, \dots, 7$. Any of the binary sub-multiples of the counter input clock can be input to the CS5501/CS5503 by jumper selection on connector P2.

The CS5501/CS5503 contains its own on-chip oscillator which needs only an external crystal to function. Ceramic resonators can be used as well although ceramic resonators and low frequency crystals will require loading capacitors for proper operation.

To test the oscillator of the CS5501/CS5503 with a crystal (Y2) a jumper wire near crystal Y2 must be opened and another jumper wire soldered into the appropriate holes provided to connect the crystal to the chip. Additional holes are provided on the board for loading capacitors.

Data Output from the CS5501/CS5503

The CS5501 has three available data output modes (The CS5503 has two available data output modes). The operating mode of the part is determined by the input voltage level to the MODE (pin 1) pin of the device. Once a mode is selected, four other pins on the device are involved in data output. The first of these is the $\overline{\text{DRDY}}$ pin (pin 18). It is an output from the chip which signals whenever a new data word is available in the internal output register of the CS5501/CS5503. Data can then be read from the register, but only when the CS pin (pin 16) is low.

When $\overline{\text{CS}}$ is low, data bits are output in serial form on the SDATA pin (pin 20). In the Synchronous Self-Clocking mode of the CS5501/CS5503, the chip provides an output data clock from the SCLK pin (pin 19). This output clock is synchronous with the output data and can be used to clock the data into an external register.

In Synchronous External-Clocking and Asynchronous Communications modes of the CS5501, the SCLK pin is an input for an external clock which determines the rate at which data bits appear at the SDATA output pin. In the CS5503, only synchronous external-clocking mode is available.

The signals necessary for reading data from the CS5501/CS5503 are all available on connector P10 as shown in Figure 2.

P-5	Data Output Mode
SSC	Synchronous Self-Clocking
SEC	Synchronous External-Clocking
AC*	Asynchronous Communications

* Available in CS5501 only.

Table 2. Data Output Mode

CS5501/CS5503 Data Output Mode Selection

Connector P5 (see Figure 2) allows jumper selection of any one of the three data output modes. These modes are:

- 1) SSC (Synchronous Self-Clocking);
- 2) SEC (Synchronous External Clocking);
- 3) AC (Asynchronous Communication).
(AC mode is available only in the CS5501)

SSC (Synchronous Self-Clocking) Mode

The SSC mode is designed for interface to those microcontrollers which allow external clocking of their serial inputs. The SSC mode also allows easy connection to serial-to-parallel conversion circuitry.

In the SSC mode serial data and serial clock are output from the CS5501/CS5503 whenever the \overline{CS} line is activated. As illustrated in Figure 2, all of the signals are available at connector P10. If the \overline{CS} signal is to be controlled remotely the jumper on P9 should be placed in the NC (No Connection) position. This removes the Decimation Counter output from controlling the \overline{CS} line.

Data Output Interface: Parallel Port (for CS5501 evaluation only).

Whenever the CS5501 is operated in the SSC mode the 16-bit output data is clocked into two 8-bit shift registers. The registers have three-state parallel outputs which are available at P7 (see Figure 3). A flip-flop (U8A) is used to signal the remote reading device whenever the registers are updated. The PDR (Parallel Data Ready) signal from the flip-flop is available on P7. The Q-bar output from the flip-flop locks out any further updates to the registers until their data is read and a DACK (Data ACKnowledge) signal is received from the remote device.

Activation of the \overline{CS} line determines the rate at which the CS5501 will attempt to update the output shift registers. Data will be shifted into the

registers only if a DACK signal has occurred since the last update.

The \overline{CS} line can be controlled remotely at P10 or by the output of the Decimation Counter. If \overline{CS} is controlled remotely, the Decimation divide jumper on P4 should be placed in the "0" position. This insures that the \overline{DCS} signal will occur at the same rate \overline{CS} is activated. The positive going edge of \overline{DCS} toggles the U8A flip-flop which signals an update to the parallel port.

The parallel registers are set up to be read in 16-bit parallel fashion but can be configured to be read separately as two 8-bit bytes on an 8-bit bus. To configure the board for byte-wide reads, the byte-wide jumpers must be soldered in place. In addition, for proper "one byte at a time" address selection, a connection on the circuit board needs to be opened and a jumper wire soldered in the proper place to determine which register is to be read when A0 is a "1" and vice versa. See Figure 3 for schematic details. The evaluation board component layout diagram, Figure 7, indicates the location of the byte-wide jumpers and A0 address selection jumpers.

After data is read from the registers a DACK (Data Acknowledge) signal is required from the off-board controller to reset flip-flop U8A. This enables the registers to accept data input once again.

The DRB and CSB signals on connector P10 should be used to monitor and control the CS5501 output to the serial to parallel conversion registers. Be aware that an arbitrarily timed DACK signal may cause the output data registers to be enabled in the middle of an output word if the \overline{CS} signal to the CS5501 is not properly sequenced. This will result in incorrect data in the output registers.

If the Decimation Counter is used to control the output of the CS5501 (Jumper on P9 in the DC position), the CSB signal on P10 can be moni-

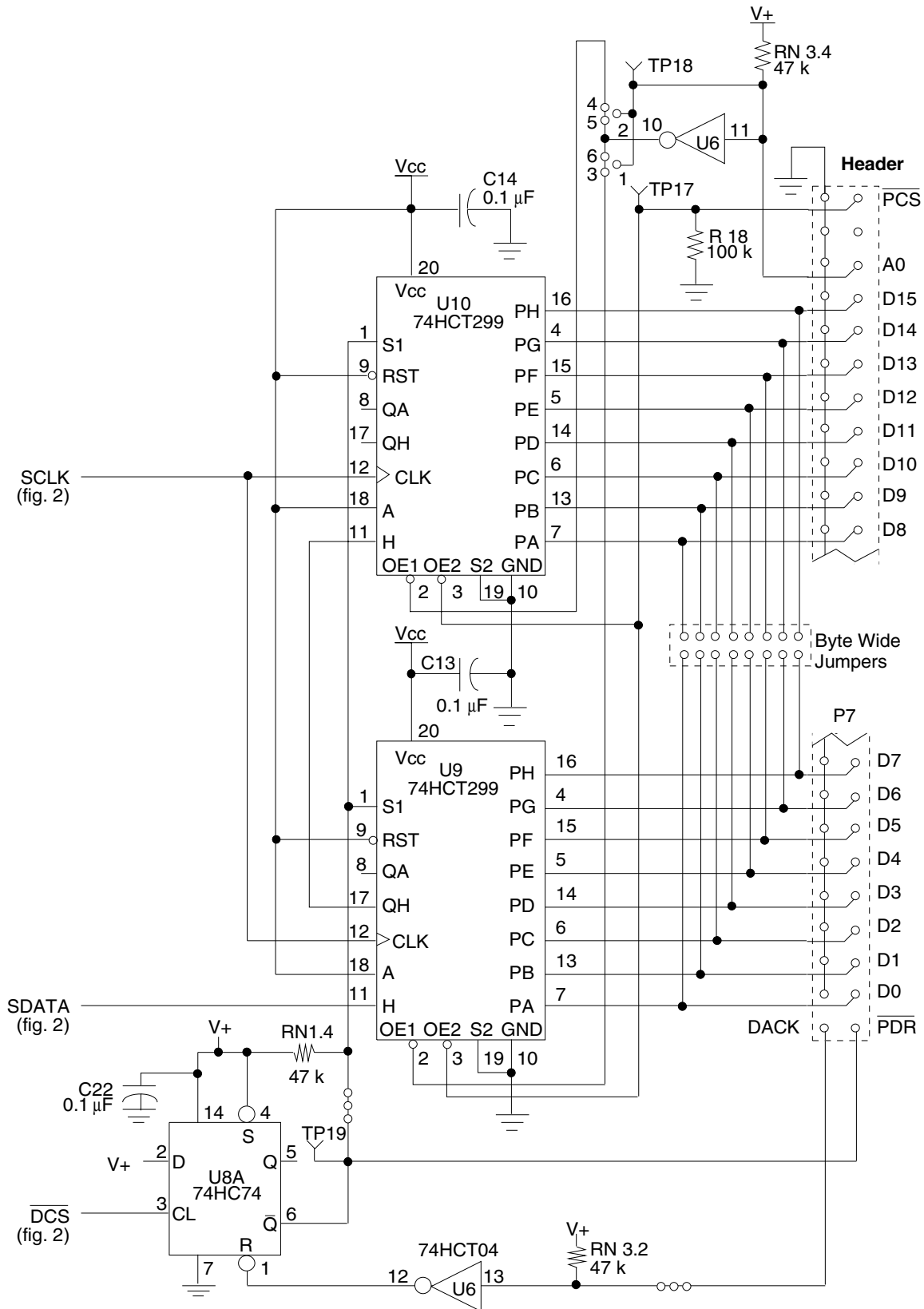

Figure 3. 16-Bit Parallel Port

tored to signal when data into the output registers is complete ($\overline{\text{DCS}}$ returns high). The $\overline{\text{DACK}}$ signal is not needed in this mode and the lockout signal to the the S1 inputs of registers U9 and U10 may be disabled by removing the connection on the circuit board. A place is provided on the board for this purpose. A pull-up resistor is provided on the S1 inputs of the registers if the connection is opened.

SEC (Synchronous External Clocking) Mode

The SEC mode enables the CS5501/CS5503 to be directly interfaced to microcontrollers which output a clock signal to synchronously input serial data to an input port. The CS5501/CS5503 will output its serial data at the rate determined by the clock from the microcontroller.

Connector P10 allows a microcontroller access to the CS5501/CS5503 signal lines which are necessary to operate in the SEC mode.

The CSB (chip select bar $\overline{\text{CS}}$) signal allows the microcontroller to control when the CS5501/CS5503 is to output data. The $\overline{\text{DRB}}$ (data

ready bar) signal on P10 indicates to the microcontroller when data from the CS5501/CS5503 is available. Clock from the microcontroller is input into SCI (serial clock input) and data output from the CS5501/CS5503 is presented to the SD (serial data) pin of the P10 connector. Note that the jumpers on connectors P9 and P11 must be in the NC (no connection) position to allow the microcontroller full control over the signals on P10.

AC (Asynchronous Communication) Mode (for CS5501 evaluation only)

The AC mode enables the CS5501 to output data in a UART-compatible format. Data is output as two characters consisting of one start bit, eight data bits, and two stop bits each.

The output data rate can be set by a clock input to the SCI input at connector P10 (see Figure 2). The jumper on P11 must be in the NC position. Alternatively an output data bit rate can be selected as a sub-multiple of the external CLKIN signal to the board or as a sub-multiple of the on-board 4.9152 MHz oscillator. Counter IC U2 divides its input by 2^n where $n = 8, 9, \dots, 12$. One of these outputs can be jumper selected at connector P3 (see Figure 1). For example, if the 4.9152 MHz oscillator is selected as the input to IC U2 then a 1200 baud rate clock can be selected with the jumper at $n = 12$. Table 3 indicates the baud rates available at connector P3 when the 4.9152 MHz oscillator is used. If the on-board baud clock is to be used, the jumper on connector P11 should be in the BC (Baud Clock) position.

Baud Rate Clock Divider ($\text{CLK}/2^n$) with INT CLK on P1 selected.
CLK = 4.9152 MHz

P-3	Baud Rate CLK Divider
8	19.2 kHz
9	9.6 kHz
10	4.8 kHz
11	2.4 kHz
12	1.2 kHz

Data Output Interface: RS-232 (for CS5501 evaluation only).

The RS232 port is depicted in Figure 4. Sub-D connector P6 along with interface IC U11 provides the necessary circuitry to connect the CS5501 to an RS-232 input of a computer. For proper operation the AC (Asynchronous Communication) data output mode must be selected. In

On-Board Baud Rate Clock Input to CS5501/CS5503 SCLK Input.

P-11	SCLK Input to CS5501/CS5503
NC	No Connection
BC	Baud Clock

Table 3. On-Board Baud Rate Generator

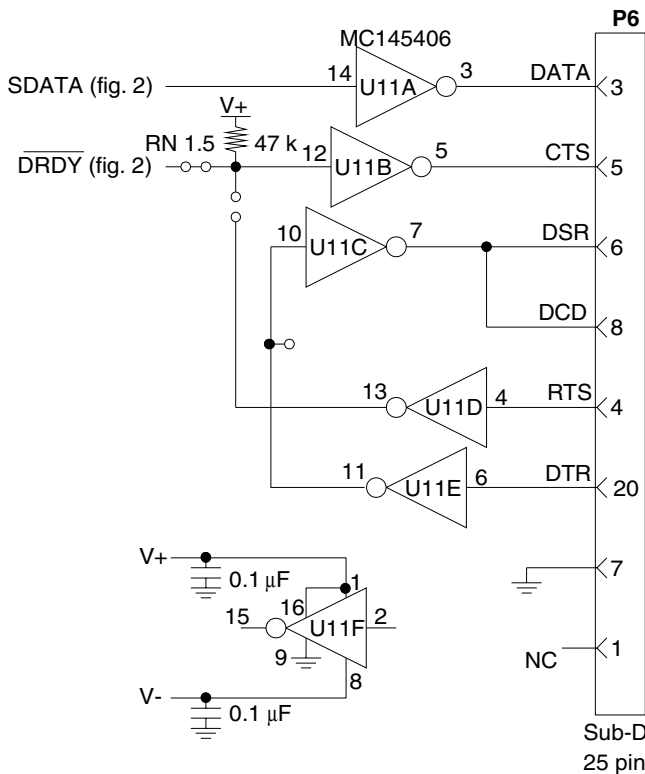

Figure 4. RS-232 Port

In addition, an appropriate baud clock needs to be input to the CS5501. See AC (Asynchronous Communication) mode mentioned earlier for an explanation of the baud rate clock generator and the data format of the output data in the AC mode.

The $\overline{\text{DRDY}}$ output from the CS5501 signals the CTS (Clear To Send) line of the RS-232 interface when data is available. The Decimation Counter can be used to determine how frequently output data is to be transmitted.

The RS-232 interface on the evaluation card is functionally adequate but it is not compliant with the EIA RS-232 standard. When the MC145406 RS-232 receiver/driver chip is operated off of ± 5 volt supplies rather than ± 6 volts (see the MC145406 data sheet for details) its driver output swing is reduced below the EIA specified limits. In practical applications this signal swing limitation only reduces the length of cable the circuit is capable of driving.

DECIMATION COUNTER

Each time a data word is available for output from the CS5501/CS5503, the $\overline{\text{DRDY}}$ line goes low, provided the output port was previously emptied. If the $\overline{\text{DRDY}}$ line is directly tied to the $\overline{\text{CS}}$ input of the CS5501/CS5503, the converter will output data every time a data word is presented to the output pin. In some applications it is desirable to reduce the output word rate. The rate

Decimation Counter Accumulates 2^{n+1} $\overline{\text{DRDY}}$ Pulses Before $\overline{\text{CS}}$ is Enabled.

P-4	2^{n+1}
0	2
1	4
2	8
3	16
4	32
5	64
6	128
7	256
8	512
9	1024
10	2048
11	4096

P-9	DC Output to $\overline{\text{CS}}$
NC	No Connection
DC	Decimation Counter

Table 4. Decimation Counter Control

can be reduced by lowering the rate at which the $\overline{\text{CS}}$ line to the chip is enabled. The CDB5501/CDB5503 evaluation board uses a counter, IC U3 for this purpose. It is known as a decimation counter (see Figure 2). The outputs of the counter are available at connector P4. The counter accumulates $2n+1$ counts ($n = 0, 2, \dots, 11$) at which time the selected output enables the $\overline{\text{CS}}$ input to the CS5501/CS5503 (if the jumper in P9 is in the DC, Decimation Counter, position). The

Switch	ON	OFF
SW1-1	SC2 = 0	SC2 = 1
SW1-2	SC1 = 0	SC1 = 1
SW1-3	UNIPOLAR	BIPOLAR
SW1-4	SLEEP	AWAKE

Table 5. DIP Switch Selections

CAL	SC1	SC2	Cal Type	ZS Cal	FS Cal	Sequence
↓	0	0	Self-Cal	AGND	VREF	One Step
↓	1	1	System Offset & System Gain	AIN	-	1st Step
↓	0	1		-	AIN	2nd Step
↓	1	0	System Offset	AIN	VREF	One Step

Table 6. Calibration Mode Table

"D" input to flip-flop U8B is enabled to a "1" at the same time \overline{CS} goes low. When \overline{DRDY} returns high flip-flop U8B is toggled and resets the counter back to zero which terminates the \overline{CS} enable. The counter then accumulates counts until the selected output activates \overline{CS} low once again.

DIP Switch Selections/Calibration Initiation

Several control pins of the CS5501/CS5503 can be level activated by DIP switch selection, or by microcontroller at P8, as shown in Figure 5. DIP switch SW1 selections are depicted in Tables 5 and 6. The CAL pushbutton is used to initiate a calibration cycle in accordance with DIP switch positions 1 and 2. The CAL pushbutton should be

activated any time power is first applied to the board or any time the conversion mode (BP/UP) is changed on the DIP switch. Remote control of the CAL signal is available on connector P8. Connector P8 also allows access to the DIP switch functions by a microcomputer/microcontroller. The DIP switches should be placed in the off position if off-board control of the signals on connector P8 is implemented.

Voltage Reference

The evaluation board includes a 2.5 volt reference. Potentiometer R9 can be used to trim the reference output to a precise value.

Analog Input Range: Unipolar Mode

The value of the reference voltage sets the analog input signal range. In unipolar mode the analog input range extends from AGND to VREF. If the analog input goes above VREF the converter will output all "1's". If the input goes below AGND, the CS5501/CS5503 will output all "0's".

Analog Input Range: Bipolar Mode

The analog signal input range in the bipolar mode is set by the reference to be from +VREF to -VREF. If the input signal goes above +VREF, the CS5501/CS5503 will output all "1's". Input signals below -VREF cause the output data to be all "0's".

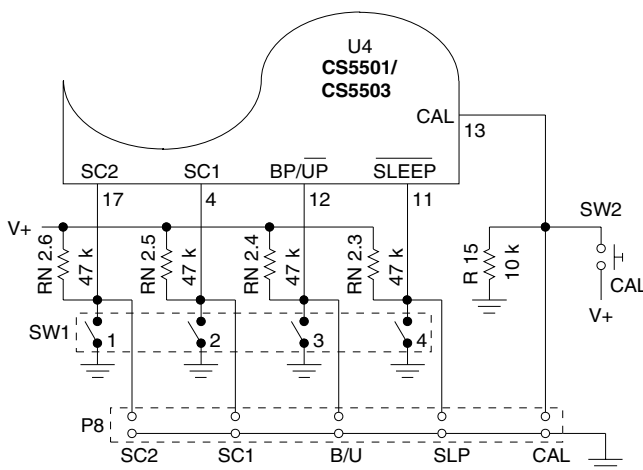

WARNING: Some evaluation boards were produced with the SC1 and SC2 labels reversed on the silkscreen

Figure 5. DIP Switch / Header Control Pin Selection

Analog Input: Overage Precautions

In normal operation the value of the reference voltage determines the range of the analog input signal. Under abnormal conditions the analog signal can extend to be equal to the VA+ and VA- supply voltages. In the event the signal exceeds these supply voltages the input current should be

limited to ± 10 mA as the analog input of the chip is internally diode clamped to both supplies. Excess current into the pin can damage the device. On the evaluation board, resistor R16 (see Figure 6) does provide some current limiting in the event of an overrange signal which exceeds the supply voltage.

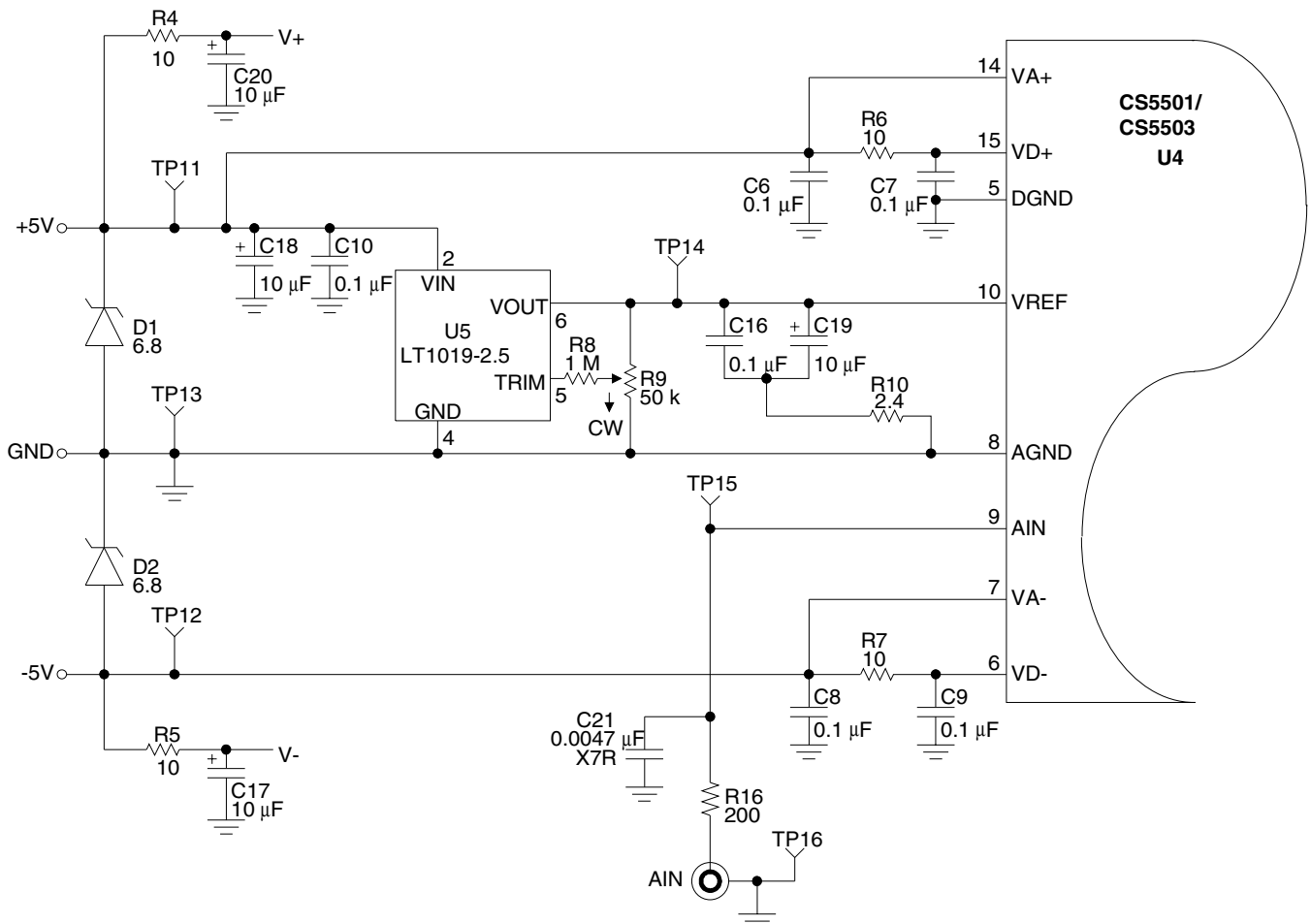

Figure 6. Voltage Reference / Analog Input

Oscilloscope Monitoring of SDATA

The output data from either the CS5501 or the CS5503 can be observed on a dual trace oscilloscope with the following hook-up. Set the evaluation board to operate in the SSC mode. Connect scope probes to TP9 (SCLK) and TP10 (SDATA). Use a third probe connected to TP8 (DRDY) to provide the external trigger input to the scope (use falling edge of DRDY to trigger). With proper horizontal sweep, the SDATA output bits from the A/D converter can be observed. Note that if the input voltage to the CS5501 is adjusted to a mid-code value, the converter will remain stable on the same output code. This illustrates the low noise level of the CS5501. The CS5503 will exhibit a few LSB's of noise in its observed output in agreement with its noise specifications.

Evaluation Board Component Layout and Design Considerations

Figure 7 is a reproduction of the silkscreen component placement of the PC board.

The evaluation board includes design features to insure proper performance from the A/D converter chip. Separate analog and digital ground planes have been used on the board to insure good noise immunity to digital system noise.

Decoupling networks (R6, C7, and R7, C9 in Figure 6) have been used to eliminate the possibility of noise on the power supplies on the digital section from affecting the analog part of the A/D converter chip.

The RC network (R10, C16 and C19) on the output of the LT1019-2.5 reference may not be needed in all applications. It has been included to insure the best noise performance from the reference .

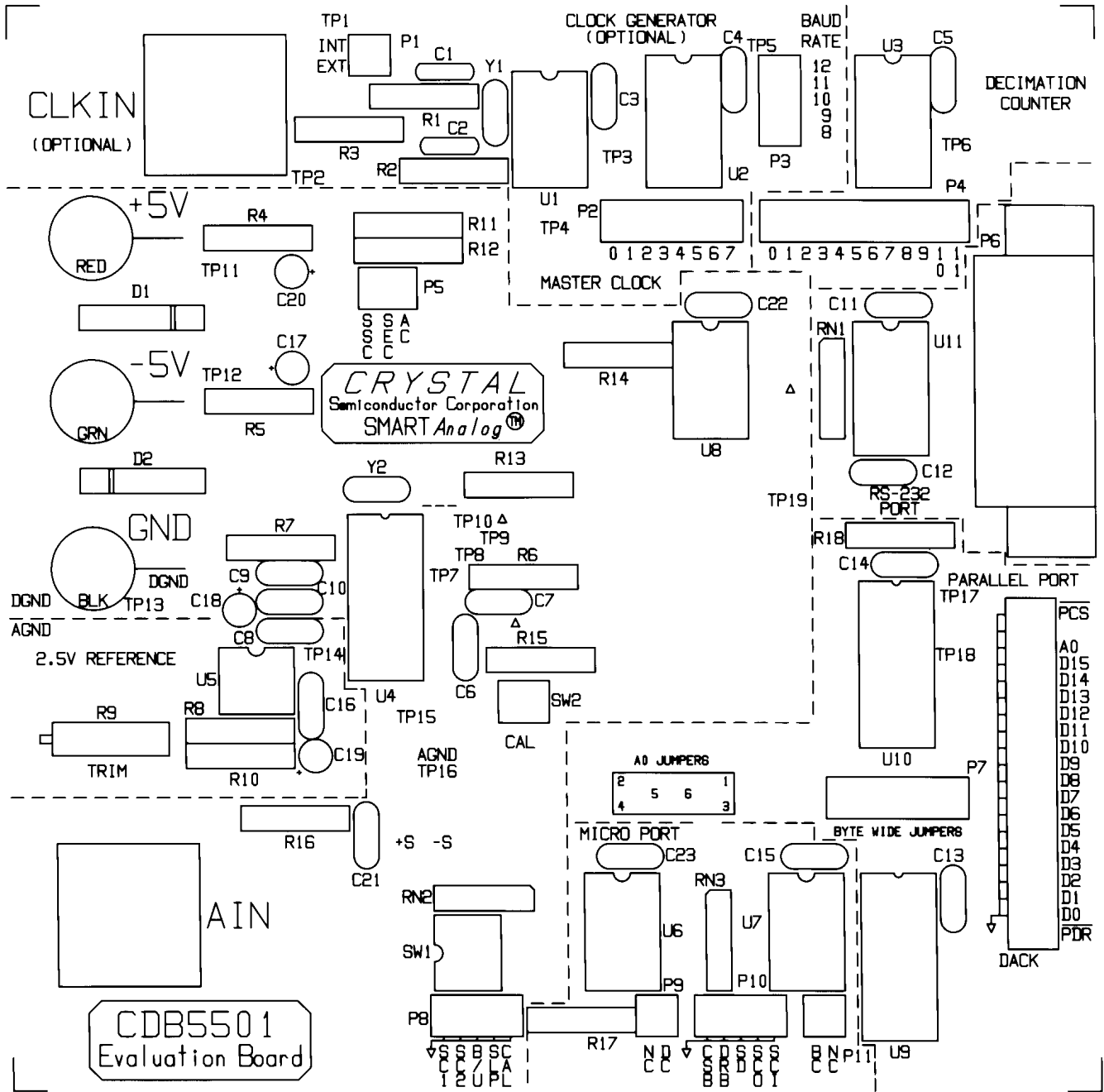

Figure 7. CDB5501/CDB5503 Component Layout

Contacting Cirrus Logic Support

For all product questions and inquiries contact a Cirrus Logic Sales Representative.

To find the one nearest to you go to www.cirrus.com

IMPORTANT NOTICE

Cirrus Logic, Inc. and its subsidiaries (“Cirrus”) believe that the information contained in this document is accurate and reliable. However, the information is subject to change without notice and is provided “AS IS” without warranty of any kind (express or implied). Customers are advised to obtain the latest version of relevant information to verify, before placing orders, that information being relied on is current and complete. All products are sold subject to the terms and conditions of sale supplier at the time of order acknowledgment, including those pertaining to warranty, indemnification, and limitation of liability. No responsibility is assumed by Cirrus for the use of this information, including use of this information as the basis for manufacture or sale of any items, or for infringement of patents or other rights of third parties. This document is the property of Cirrus and by furnishing this information, Cirrus grants no license, express or implied under any patents, mask work rights, copyrights, trademarks, trade secrets or other intellectual property rights. Cirrus owns the copyrights associated with the information contained herein and gives consent for copies to be made of the information only for use within your organization with respect to Cirrus integrated circuits or other products of Cirrus. This consent does not extend to other copying such as copying for general distribution, advertising or promotional purposes, or for creating any work for resale.

CERTAIN APPLICATIONS USING SEMICONDUCTOR PRODUCTS MAY INVOLVE POTENTIAL RISKS OF DEATH, PERSONAL INJURY, OR SEVERE PROPERTY OR ENVIRONMENTAL DAMAGE (“CRITICAL APPLICATIONS”). CIRRUS PRODUCTS ARE NOT DESIGNED, AUTHORIZED OR WARRANTED FOR USE IN AIRCRAFT SYSTEMS, MILITARY APPLICATIONS, PRODUCTS SURGICALLY IMPLANTED INTO THE BODY, AUTOMOTIVE SAFETY OR SECURITY DEVICES LIFE SUPPORT PRODUCTS OR OTHER CRITICAL APPLICATIONS. INCLUSION OF CIRRUS PRODUCTS IN SUCH APPLICATIONS IS UNDERSTOOD TO BE FULLY AT THE CUSTOMER’S RISK AND CIRRUS DISCLAIMS AND MAKES NO WARRANTY, EXPRESS, STATUTORY OR IMPLIED, INCLUDING THE IMPLIED WARRANTIES OF MERCHANTABILITY AND FITNESS FOR PARTICULAR PURPOSE, WITH REGARD TO ANY CIRRUS PRODUCT THAT IS USED IN SUCH A MANNER. IF THE CUSTOMER OR CUSTOMER’S CUSTOMER USES OR PERMITS THE USE OF CIRRUS PRODUCTS IN CRITICAL APPLICATIONS, CUSTOMER AGREES, BY SUCH USE, TO FULLY INDEMNIFY CIRRUS, ITS OFFICERS, DIRECTORS, EMPLOYEES, DISTRIBUTORS AND OTHER AGENTS FROM ANY AND ALL LIABILITY, INCLUDING ATTORNEYS’ FEES AND COSTS, THAT MAY RESULT FROM OR ARISE IN CONNECTION WITH THESE USES.

Cirrus Logic, Cirrus, and the Cirrus Logic logo designs are trademarks of Cirrus Logic, Inc. All other brand and product names in this document may be trademarks or service marks of their respective owners.