



LINEAR INTEGRATED CIRCUITS

HIGH-CURRENT FLOATING SWITCH DRIVER

DESCRIPTION

The SG1629 and SG3629 are monolithic integrated circuits designed to generate the positive and negative base drive currents (i_{b1} and i_{b2}) required for high-speed, high power switching transistors. These units are intended to interface between the secondary of a drive transformer and the base of an NPN switching device. Positive drive current can be made constant with an external programming resistor, or can be clamped with a diode to keep the switching device out of saturation. Negative turn-off current is derived from a negative voltage generated in an external capacitor. All operating power is supplied by the transformer secondary and these devices can be floated at high levels with respect to ground for off-line, bridge converters.

For medium power applications, these units are available in 10-pin, TO-100 package; while high power capability is offered in a 9-pin, TO-66 case. In either package, the SG1629 is specified for operation over an ambient temperature range of -55°C to 125°C while the SG3629 is intended for industrial applications of 0 to 70°C .

FEATURES

- Self-generating positive and negative currents
- Constant source current (i_{b1}) to one amp
- Two amp peak sink current (i_{b2}) to negative voltage
- Floating operation
- Baker clamp input for non-saturated switching
- Provisions for source and sink gating
- 100ns response

HIGH RELIABILITY FEATURES - SG1629

- ◆ Available to MIL-STD-883
- ◆ SG level "S" processing available

SCHEMATIC

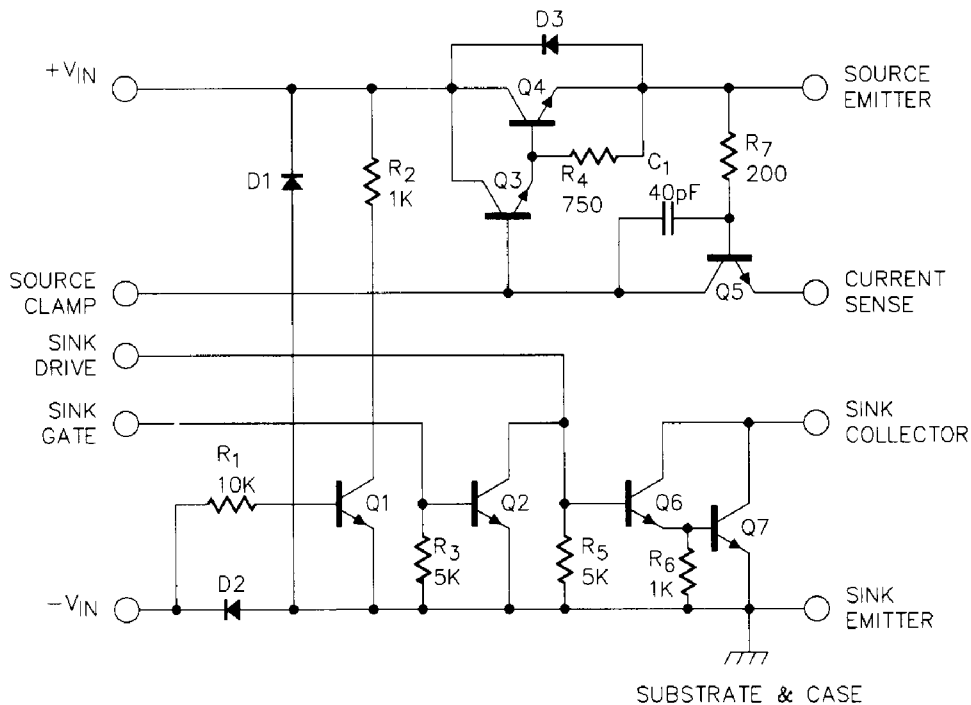

ABSOLUTE MAXIMUM RATINGS (Note 1)

Input Voltage (+V _{IN} or -V _{IN})	20V	Sink Rectifier Current (peak)	2.0A
Collector to Emitter Voltage, Source or Sink	20V	Operating Junction Temperature	
Source Current	2.0A	Hermetic (T, R Packages)	150°C
Sink Current	3.0A	Storage Temperature Range	-65°C to 150°C
		Lead Temperature (Soldering, 10 Seconds)	300°C

Note 1. Exceeding these ratings could cause damage to the device.

THERMAL DERATING CURVES

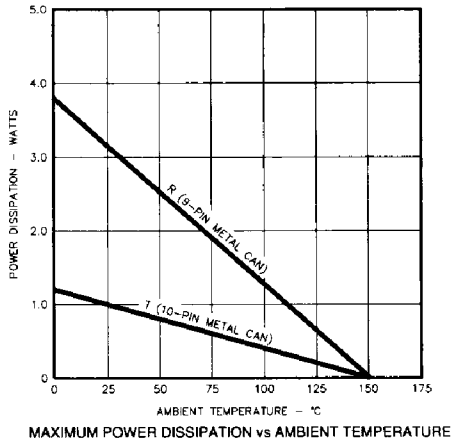

MAXIMUM POWER DISSIPATION vs AMBIENT TEMPERATURE

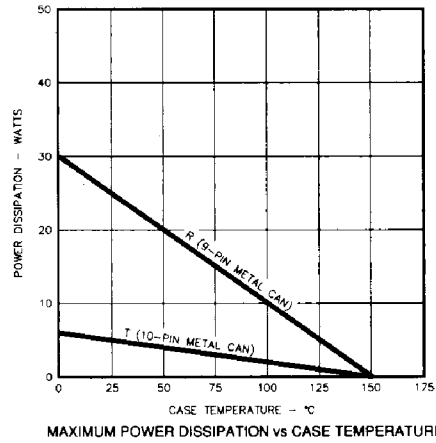

MAXIMUM POWER DISSIPATION vs CASE TEMPERATURE

RECOMMENDED OPERATING CONDITIONS (Note 2)

Input Voltage (+V _{IN} or -V _{IN})	15V	Sink Rectifier Current (Peak)	0A to 1A
Collector to Emitter Voltage, Source or Sink	15V	Operating Ambient Temperature Range	
Source Current	0A to 1A	SG1629	-55°C to 125°C
Sink Current	0A to 2A	SG3629	0°C to 70°C

Note 2. Range over which the device is functional.

ELECTRICAL SPECIFICATIONS

(Unless otherwise specified, these specifications apply over the operating ambient temperatures for SG1629 with -55°C ≤ T_A ≤ 125°C, SG3629 with 0°C ≤ T_A ≤ 70°C. Low duty cycle pulse testing techniques are used which maintains junction and case temperatures equal to the ambient temperature.)

Parameter	Test Conditions	SG1629/SG3629			Units
		Min.	Typ.	Max.	
Collector to Emitter Voltage, Source or Sink	V _{BE} = 0	20	30		V
Collector to Emitter Leakage, Source or Sink	V _{BE} = 0, V _{CE} = 15V		5	100	μA
Input Leakage V+ to V-	Input Voltage = +15V		1	100	μA
Input Leakage V- to V+	Input Voltage = -15V		2	4	mA
Standby Current from Sink Emitter Voltage (Note 3)	Sink Emitter = -5V, +V _{IN} = -V _{IN} = 0V		5	10	mA
Clamp Current	+V _{IN} = 15V, V _{clamp} = 0V	10	15	20	mA
Source Saturation Voltage	I _{SOURCE} = 100mA		1.7		V
	I _{SOURCE} = 500mA		1.8		V
	I _{SOURCE} = 1A, T _A = 25°C		2.0	3	V
Sink Saturation Voltage, Force beta = 100	I _{SINK} = 100mA		1.2		V
	I _{SINK} = 500mA		1.3		V
	I _{SINK} = 1A, T _A = 25°C		1.5	2	V
Sink Current Gain	I _{SINK} = 2A, V _{CE} = 3V	300	500		
Current Limit Sense Voltage	R _{SC} = 0.7Ω, T _A = 25°C	0.55	0.65	0.80	V
Sink Rectifier Forward Voltage	I _F = 1A, T _A = 25°C		1.0	2.0	V
Sink Gate Output Saturation	Sink Drive = 10mA, Sink Gate I _{IN} = 1mA		0.2	0.4	V
Source Response	I _{SOURCE} = 1A		100		ns
Sink Response	I _{SINK} = 1A		100		ns

Note 3. 1KΩ from -V_{IN} to Sink Drive and Source Emitter connected to Sink Collector.

CHARACTERISTIC CURVES

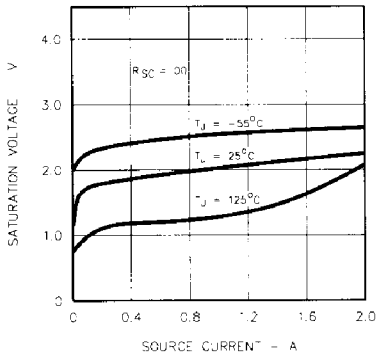

FIGURE 1. SOURCE SATURATION

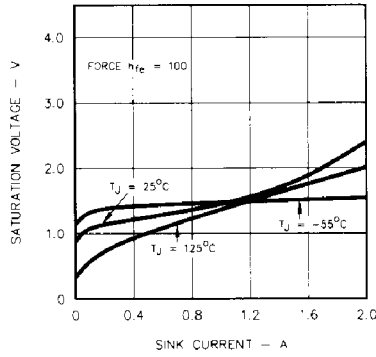

FIGURE 2. SINK SATURATION

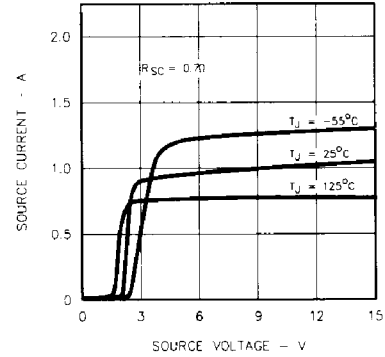

FIGURE 3. CONSTANT SOURCE CURRENT

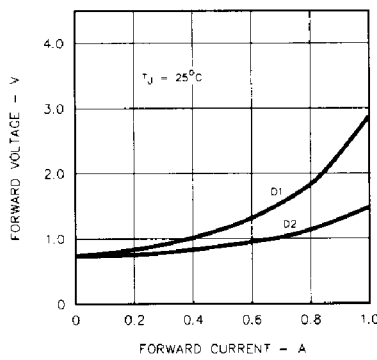

FIGURE 4. RECTIFIER FORWARD VOLTAGE

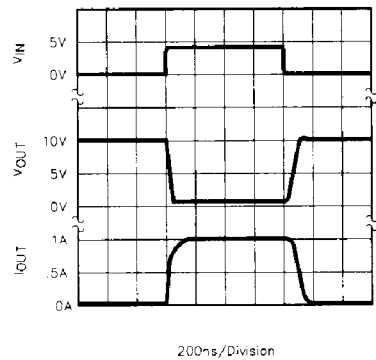

FIGURE 5. DYNAMIC RESPONSE WAVEFORM

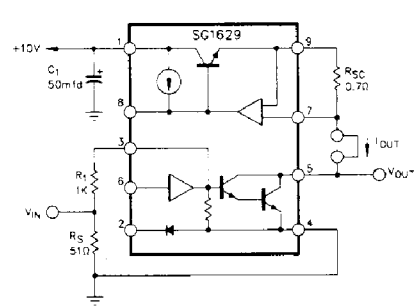

FIGURE 6. DYNAMIC RESPONSE TEST CIRCUIT

6

APPLICATION CIRCUITS

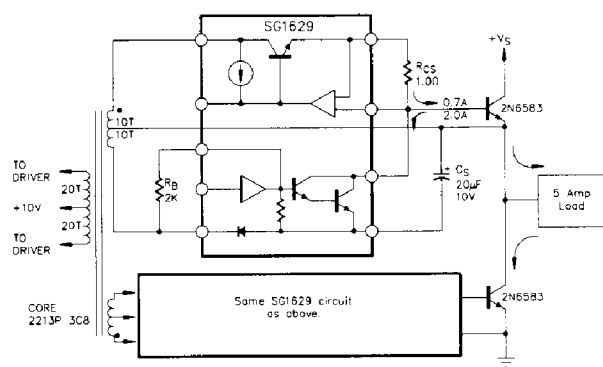

FIGURE 6

Two SG1629 devices can be combined to form the drive signals for the power transistors in a 5A, half-bridge switching supply.

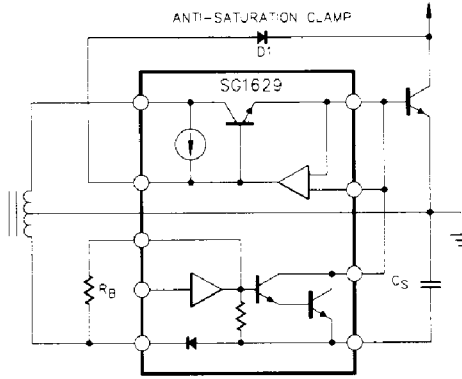

FIGURE 7

A load-dependent drive current may be provided by eliminating the current sensing resistor and adding the anti-saturation clamp diode D_1 .

APPLICATION CIRCUITS (continued)

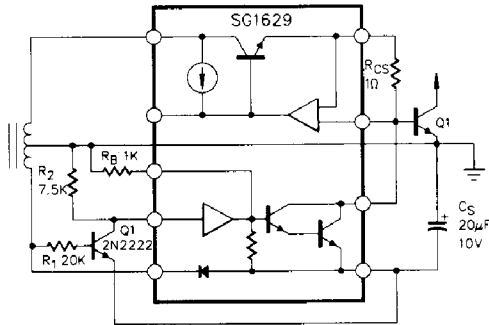

FIGURE 8

Where transformer inductance would normally degrade turn-on current rise time, the use of the sink gate with a relatively slow external transistor, Q1, will delay the sink turn-off until after source current has been

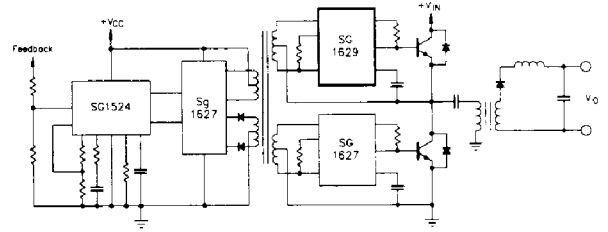

FIGURE 9

A simplified drive system for a half-bridge switched mode converter. A full bridge drive may be accommodated with four SG1629 drivers and additional current boosting for the SG1627.

CONNECTION DIAGRAMS & ORDERING INFORMATION (See Notes Below)

Package	Part No.	Ambient Temperature Range	Connection Diagram
9-PIN METAL CAN R - PACKAGE	SG1629R/883B SG1629R SG3629R	-55°C to 125°C -55°C to 125°C 0°C to 70°C	
10-PIN METAL CAN T - PACKAGE	SG1629T/883B SG1629T SG3629T	-55°C to 125°C -55°C to 125°C 0°C to 70°C	

- Note
1. Contact factory for JAN and DESC product availability.
 2. All packages are viewed from the top.
 3. Case is internally connected to pin 4 on both packages.