

HD74LV273A

Octal D-type Flip-Flops with Clear

HITACHI

ADE-205-273 (Z)
1st Edition
April 1999

Description

The HD74LV273A has eight edge trigger D-type flip-flops with clear in a 20-pin package. Data on the D input having the specified setup and hold times is transferred to the Q output on the low to high transition of the clock input. The clear input when low, sets all outputs to a low state. Low-voltage and high-speed operation is suitable for battery-powered products (e.g., notebook computers), and the low-power consumption extends the battery life.

Features

- $V_{CC} = 2.0\text{ V}$ to 5.5 V operation
- All inputs V_{IH} (Max.) = 5.5 V (@ $V_{CC} = 0\text{ V}$ to 5.5 V)
- All outputs V_O (Max.) = 5.5 V (@ $V_{CC} = 0\text{ V}$)
- Typical V_{OL} ground bounce $< 0.8\text{ V}$ (@ $V_{CC} = 3.3\text{ V}$, $T_a = 25^\circ\text{C}$)
- Typical V_{OH} undershoot $> 2.3\text{ V}$ (@ $V_{CC} = 3.3\text{ V}$, $T_a = 25^\circ\text{C}$)
- Output current $\pm 6\text{ mA}$ (@ $V_{CC} = 3.0\text{ V}$ to 3.6 V), $\pm 16\text{ mA}$ (@ $V_{CC} = 4.5\text{ V}$ to 5.5 V)

Function Table

Inputs			
CLR	CLK	D	Output Q
L	X	X	L
H	↑	H	H
H	↑	L	L
H	↓	X	Q_0

Note: H: High level

L: Low level

X: Immaterial

↑: Low to high transition

↓: High to low transition

Q_0 : Output level before the indicated steady state input conditions were established.

HD74LV273A

Pin Arrangement

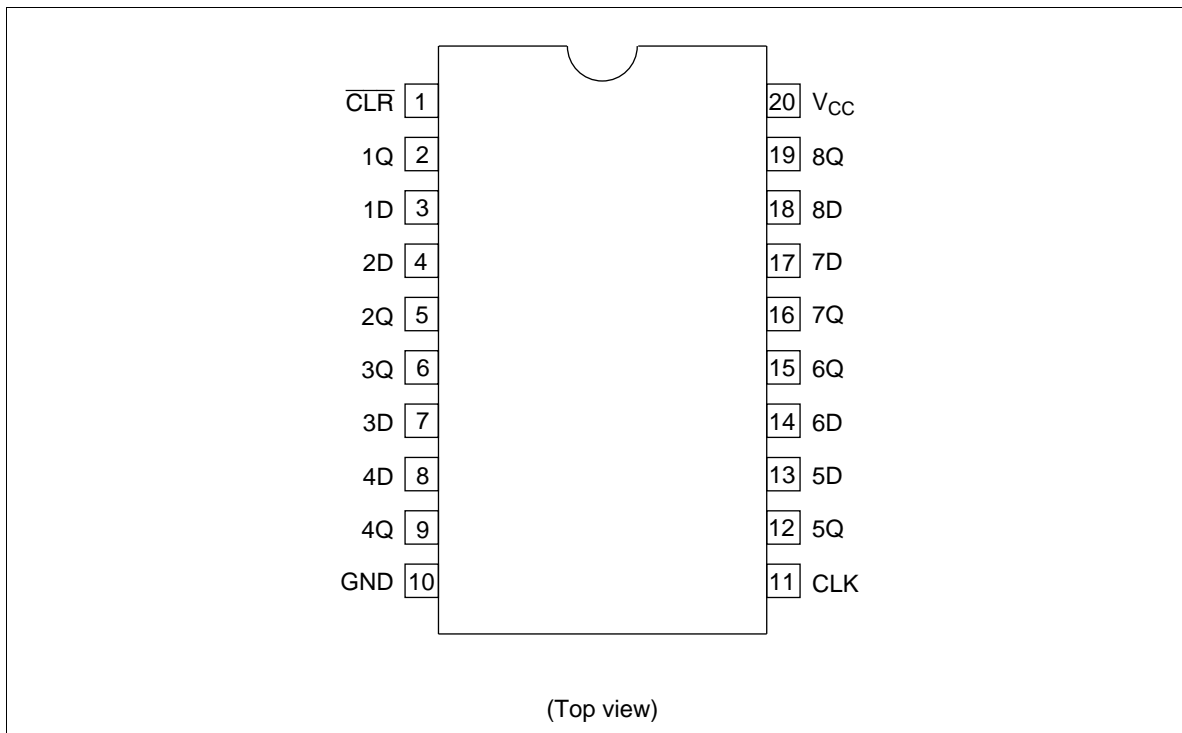

Absolute Maximum Ratings

Item	Symbol	Ratings	Unit	Conditions
Supply voltage range	V_{CC}	-0.5 to 7.0	V	
Input voltage range* ¹	V_I	-0.5 to 7.0	V	
Output voltage range* ^{1, 2}	V_O	-0.5 to $V_{CC} + 0.5$ -0.5 to 7.0	V	Output: H or L V_{CC} : OFF
Input clamp current	I_{IK}	-20	mA	$V_I < 0$
Output clamp current	I_{OK}	± 50	mA	$V_O < 0$ or $V_O > V_{CC}$
Continuous output current	I_O	± 25	mA	$V_O = 0$ to V_{CC}
Continuous current through V_{CC} or GND	I_{CC} or I_{GND}	± 50	mA	
Maximum power dissipation at $T_a = 25^\circ\text{C}$ (in still air)* ³	P_T	835 757	mW	SOP TSSOP
Storage temperature	T_{stg}	-65 to 150	$^\circ\text{C}$	

Notes: The absolute maximum ratings are values which must not individually be exceeded, and furthermore, no two of which may be realized at the same time.

1. The input and output voltage ratings may be exceeded if the input and output clamp-current ratings are observed.
2. This value is limited to 5.5 V maximum.
3. The maximum package power dissipation was calculated using a junction temperature of 150 $^\circ\text{C}$.

HD74LV273A

Recommended Operating Conditions

Item	Symbol	Min	Max	Unit	Conditions
Supply voltage range	V_{CC}	2.0	5.5	V	
Input voltage range	V_I	0	5.5	V	
Output voltage range	V_O	0	V_{CC}	V	H or L
Output current	I_{OH}	—	-50	μA	$V_{CC} = 2.0 V$
		—	-2	mA	$V_{CC} = 2.3 \text{ to } 2.7 V$
		—	-6		$V_{CC} = 3.0 \text{ to } 3.6 V$
		—	-12		$V_{CC} = 4.5 \text{ to } 5.5 V$
	I_{OL}	—	50	μA	$V_{CC} = 2.0 V$
		—	2	mA	$V_{CC} = 2.3 \text{ to } 2.7 V$
		—	6		$V_{CC} = 3.0 \text{ to } 3.6 V$
		—	12		$V_{CC} = 4.5 \text{ to } 5.5 V$
Input transition rise or fall rate	$\Delta t / \Delta v$	0	200	ns/V	$V_{CC} = 2.3 \text{ to } 2.7 V$
		0	100		$V_{CC} = 3.0 \text{ to } 3.6 V$
		0	20		$V_{CC} = 4.5 \text{ to } 5.5 V$
Operating free-air temperature	T_a	-40	85	$^{\circ}C$	

Note: Unused or floating inputs must be held high or low.

Logic Diagram

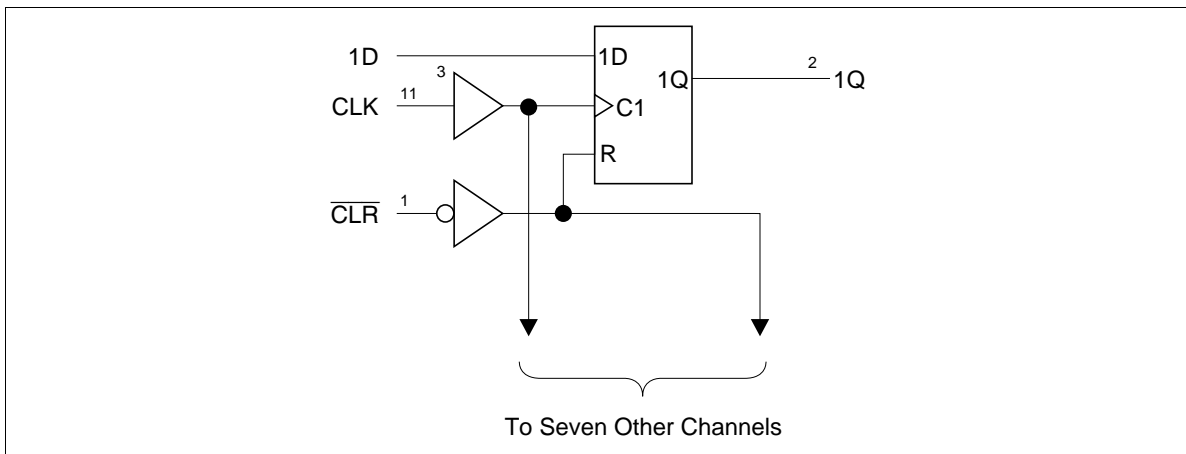

DC Electrical Characteristics

• Ta = -40 to 85°C

Item	Symbol	V _{CC} (V)*	Min	Typ	Max	Unit	Test Conditions
Input voltage	V _{IH}	2.0	1.5	—	—	V	
		2.3 to 2.7	V _{CC} × 0.7	—	—		
		3.0 to 3.6	V _{CC} × 0.7	—	—		
		4.5 to 5.5	V _{CC} × 0.7	—	—		
	V _{IL}	2.0	—	—	0.5		
		2.3 to 2.7	—	—	V _{CC} × 0.3		
		3.0 to 3.6	—	—	V _{CC} × 0.3		
		4.5 to 5.5	—	—	V _{CC} × 0.3		
Output voltage	V _{OH}	Min to Max	V _{CC} - 0.1	—	—	V	I _{OH} = -50 μA
		2.3	2.0	—	—		I _{OH} = -2 mA
		3.0	2.48	—	—		I _{OH} = -6 mA
		4.5	3.8	—	—		I _{OH} = -12 mA
	V _{OL}	Min to Max	—	—	0.1		I _{OL} = 50 μA
		2.3	—	—	0.4		I _{OL} = 2 mA
		3.0	—	—	0.44		I _{OL} = 6 mA
		4.5	—	—	0.55		I _{OL} = 12 mA
Input current	I _{IN}	0 to 5.5	—	—	±1	μA	V _I = 5.5 V or GND
Quiescent supply current	I _{CC}	5.5	—	—	20	μA	V _I = V _{CC} or GND, I _O = 0
Output leakage current	I _{OFF}	0	—	—	5	μA	V _I or V _O = 0 V to 5.5 V
Input capacitance	C _{IN}	3.3	—	2	—	pF	V _I = V _{CC} or GND

Note: For conditions shown as Min or Max, use the appropriate values under recommended operating conditions.

HD74LV273A

Switching Characteristics

- $V_{CC} = 2.5 \pm 0.2 V$

Item	Symbol	Ta = 25°C			Ta = -40 to 85°C		Unit	Test Conditions	FROM (Input)	TO (Output)
		Min	Typ	Max	Min	Max				
Maximum clock frequency	fmax	55	95	—	45	—	MHz	CL = 15 pF		
		45	75	—	40	—				
Propagation delay time	tPHL	—	10.3	19.0	1.0	21.0	ns	CL = 15 pF	\overline{CLR}	Q
	tPLH / tPHL	—	10.4	18.3	1.0	20.5			CLK	Q
	tPHL	—	13.1	22.8	1.0	25.5	ns	CL = 50 pF	\overline{CLR}	Q
	tPLH / tPHL	—	12.9	22.1	1.0	25.0			CLK	Q
Setup time	tSU	8.5	—	—	10.5	—	ns		Data	
		4.0	—	—	4.0	—			\overline{CLR} inactive	
Hold time	th	0.5	—	—	1.0	—	ns			
Pulse width	tw	6.5	—	—	7.0	—	ns		\overline{CLR} L	
		7.0	—	—	8.5	—			CLK H or L	

Switching Characteristics (cont)

- $V_{CC} = 3.3 \pm 0.3 V$

Item	Symbol	Ta = 25°C			Ta = -40 to 85°C		Unit	Test Conditions	FROM (Input)	TO (Output)
		Min	Typ	Max	Min	Max				
Maximum clock frequency	fmax	75	140	—	65	—	MHz	CL = 15 pF		
		50	110	—	45	—				
Propagation delay time	t _{PHL}	—	6.9	13.6	1.0	16.0	ns	CL = 15 pF	\overline{CLR}	Q
	t _{PLH} / t _{PHL}	—	7.1	13.6	1.0	16.0			CLK	Q
	t _{PHL}	—	8.7	17.1	1.0	19.5	ns	CL = 50 pF	\overline{CLR}	Q
	t _{PLH} / t _{PHL}	—	9.1	17.1	1.0	19.5			CLK	Q
Setup time	t _{SU}	5.5	—	—	6.5	—	ns		Data	
		2.5	—	—	2.5	—			\overline{CLR} inactive	
Hold time	t _H	1.0	—	—	1.0	—	ns			
Pulse width	t _W	5.0	—	—	6.0	—	ns		\overline{CLR} L	
		5.5	—	—	6.5	—			CLK H or L	

HD74LV273A

Switching Characteristics (cont)

- $V_{CC} = 5.0 \pm 0.5 \text{ V}$

Item	Symbol	Ta = 25°C			Ta = -40 to 85°C		Unit	Test Conditions	FROM (Input)	TO (Output)
		Min	Typ	Max	Min	Max				
Maximum clock frequency	fmax	120	205	—	100	—	MHz	CL = 15 pF		
		80	160	—	70	—				
Propagation delay time	t _{PHL}	—	4.7	8.5	1.0	10.0	ns	CL = 15 pF	$\overline{\text{CLR}}$	Q
	t _{PLH} / t _{PHL}	—	4.8	9.0	1.0	10.5			CLK	Q
	t _{PHL}	—	6.0	10.5	1.0	12.0	ns	CL = 50 pF	$\overline{\text{CLR}}$	Q
	t _{PLH} / t _{PHL}	—	6.2	11.0	1.0	12.5			CLK	Q
Setup time	t _{SU}	4.5	—	—	4.5	—	ns		Data	
		2.0	—	—	2.0	—			$\overline{\text{CLR}}$ inactive	
Hold time	t _H	1.0	—	—	1.0	—	ns			
Pulse width	t _W	5.0	—	—	5.0	—	ns		$\overline{\text{CLR}}$ L	
		5.0	—	—	5.0	—			CLK H or L	

Output-skew Characteristics

Item	Symbol	V _{CC} = (V)	Ta = 25°C		Ta = -40 to 85°C		Unit
			Min	Max	Min	Max	
Output skew	t _{sk(O)}	2.3 to 2.7	—	2.0	—	2.0	ns
		3.0 to 3.6	—	1.5	—	1.5	
		4.5 to 5.5	—	1.0	—	1.0	

Note: Skew between any outputs of the same package switching in the same direction. This parameter is warranted but not production tested.

Operating Characteristics

- C_L = 50 pF

Item	Symbol	V _{CC} = (V)	Ta = 25°C			Unit	Test Conditions
			Min	Typ	Max		
Power dissipation capacitance	C _{PD}	3.3	—	15.9	—	pF	f = 10 MHz
		5.0	—	17.1	—		

Noise Characteristics

- C_L = 50 pF

Item	Symbol	V _{CC} = (V)	Ta = 25°C			Unit	Test Conditions
			Min	Typ	Max		
Quiet output, maximum dynamic V _{OL}	V _{OL(P)}	3.3	—	0.4	0.8	V	
Quiet output, minimum dynamic V _{OL}	V _{OL(V)}	3.3	—	-0.4	-0.8		
Quiet output, minimum dynamic V _{OH}	V _{OH(V)}	3.3	—	2.9	—	V	
High-level dynamic input voltage	V _{IH(D)}	3.3	2.31	—	—		
Low-level dynamic input voltage	V _{IL(D)}	3.3	—	—	0.99		

HD74LV273A

Test Circuit

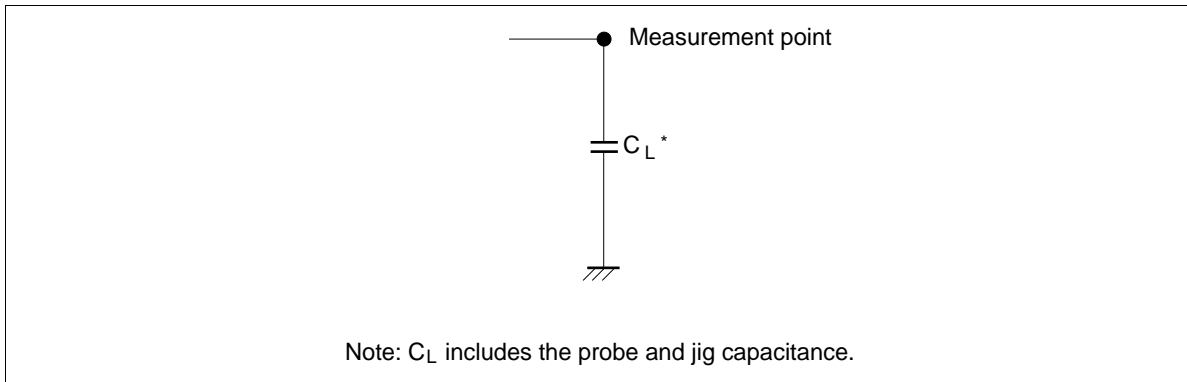

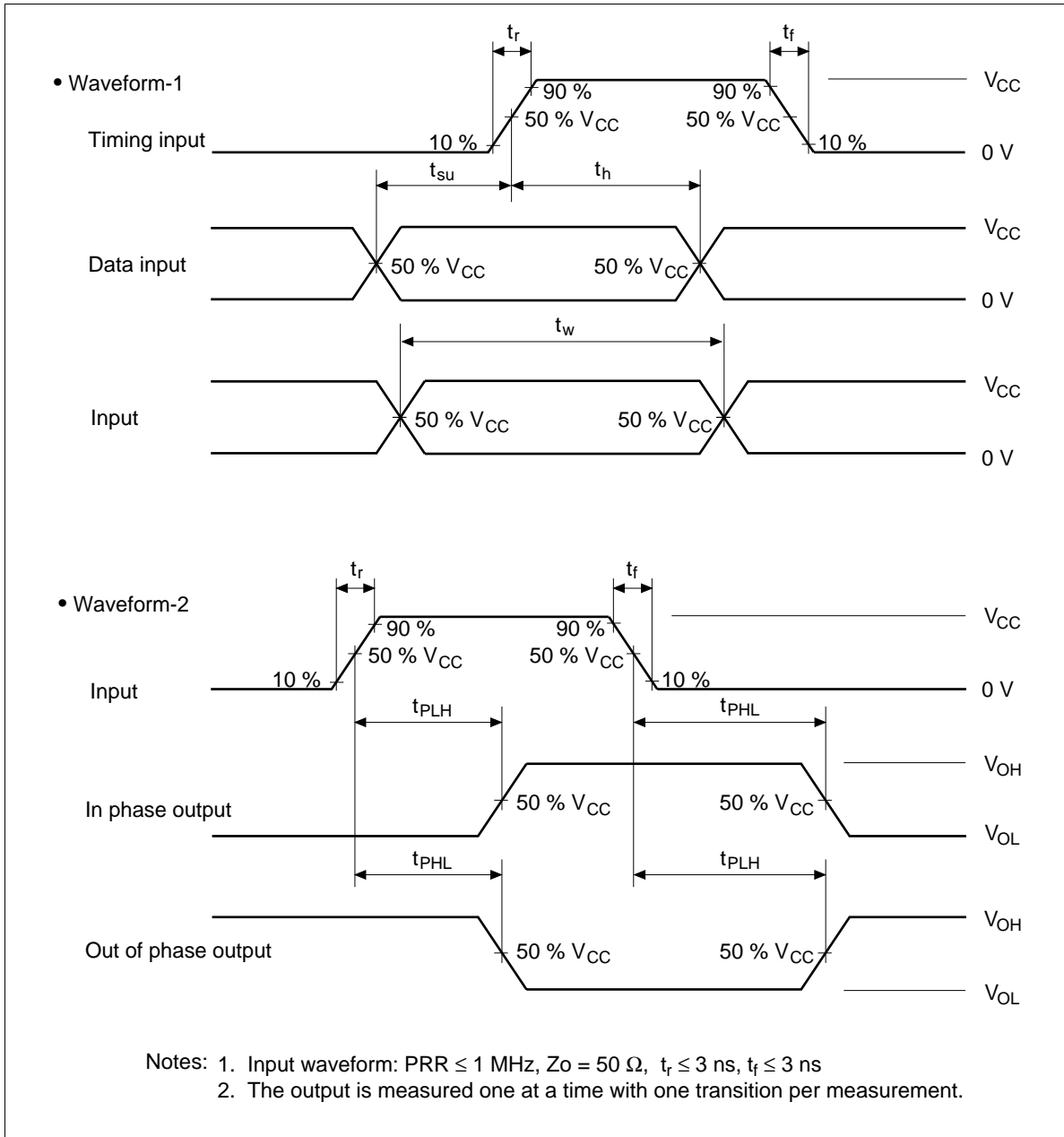

HD74LV273A

Package Dimensions

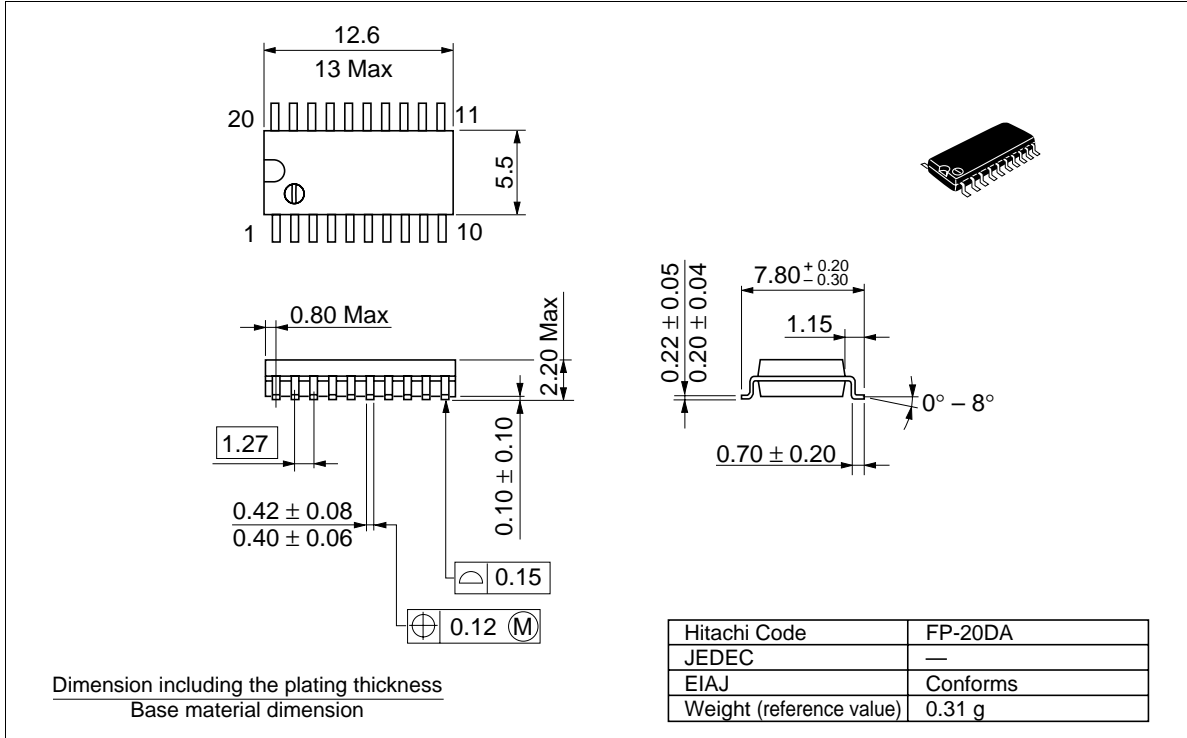

HD74LV273A

Unit: mm

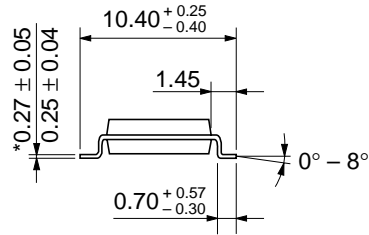
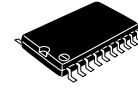
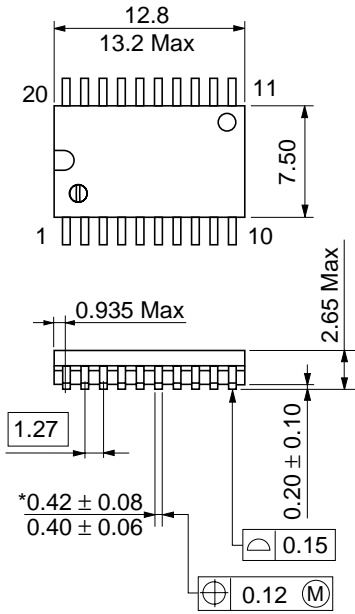

*Dimension including the plating thickness
Base material dimension

Hitachi Code	FP-20DB
JEDEC	Conforms
EIAJ	—
Weight (reference value)	0.52 g

HD74LV273A

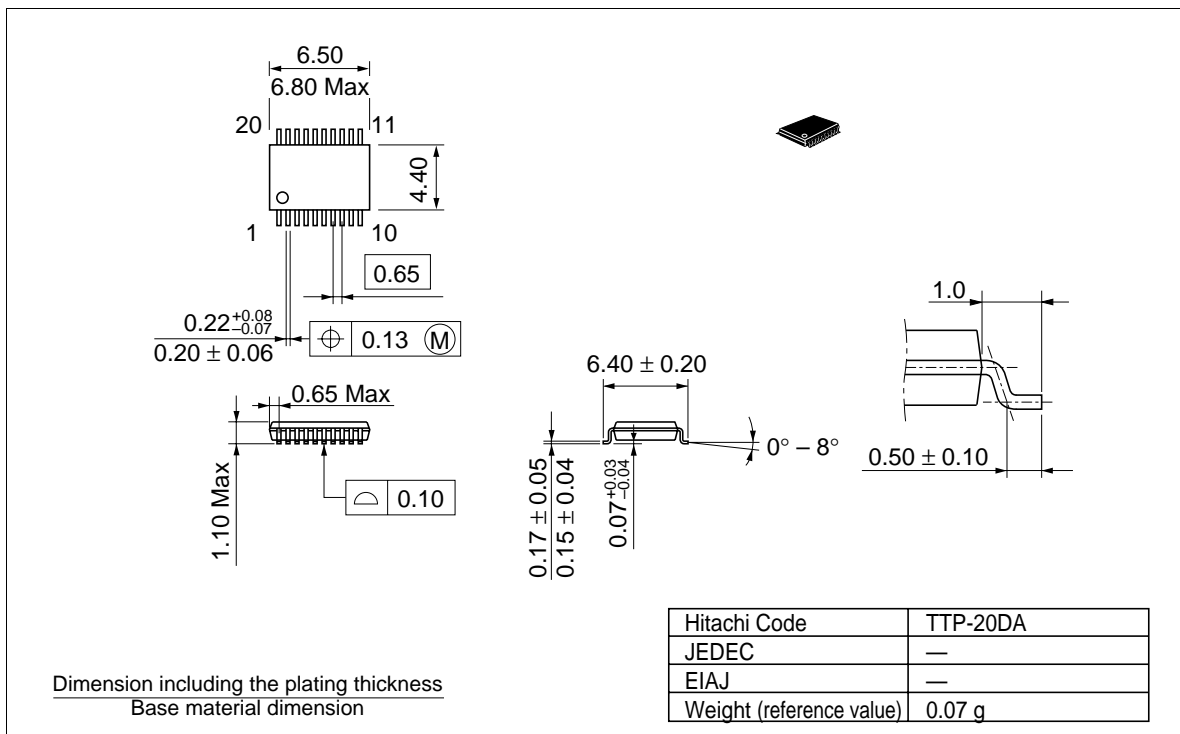

Cautions

1. Hitachi neither warrants nor grants licenses of any rights of Hitachi's or any third party's patent, copyright, trademark, or other intellectual property rights for information contained in this document. Hitachi bears no responsibility for problems that may arise with third party's rights, including intellectual property rights, in connection with use of the information contained in this document.
2. Products and product specifications may be subject to change without notice. Confirm that you have received the latest product standards or specifications before final design, purchase or use.
3. Hitachi makes every attempt to ensure that its products are of high quality and reliability. However, contact Hitachi's sales office before using the product in an application that demands especially high quality and reliability or where its failure or malfunction may directly threaten human life or cause risk of bodily injury, such as aerospace, aeronautics, nuclear power, combustion control, transportation, traffic, safety equipment or medical equipment for life support.
4. Design your application so that the product is used within the ranges guaranteed by Hitachi particularly for maximum rating, operating supply voltage range, heat radiation characteristics, installation conditions and other characteristics. Hitachi bears no responsibility for failure or damage when used beyond the guaranteed ranges. Even within the guaranteed ranges, consider normally foreseeable failure rates or failure modes in semiconductor devices and employ systemic measures such as fail-safes, so that the equipment incorporating Hitachi product does not cause bodily injury, fire or other consequential damage due to operation of the Hitachi product.
5. This product is not designed to be radiation resistant.
6. No one is permitted to reproduce or duplicate, in any form, the whole or part of this document without written approval from Hitachi.
7. Contact Hitachi's sales office for any questions regarding this document or Hitachi semiconductor products.

HITACHI

Hitachi, Ltd.

Semiconductor & Integrated Circuits.

Nippon Bldg., 2-6-2, Ohte-machi, Chiyoda-ku, Tokyo 100-0004, Japan
Tel: Tokyo (03) 3270-2111 Fax: (03) 3270-5109

URL North America : <http://semiconductor.hitachi.com/>
 Europe : <http://www.hitachi-eu.com/hel/ecg>
 Asia (Singapore) : <http://www.has.hitachi.com.sg/grp3/sicd/index.htm>
 Asia (Taiwan) : http://www.hitachi.com.tw/E/Product/SICD_Frame.htm
 Asia (HongKong) : <http://www.hitachi.com.hk/eng/bo/grp3/index.htm>
 Japan : <http://www.hitachi.co.jp/Sicd/indx.htm>

For further information write to:

Hitachi Semiconductor
(America) Inc.
179 East Tasman Drive,
San Jose, CA 95134
Tel: <1> (408) 433-1990
Fax: <1> (408) 433-0223

Hitachi Europe GmbH
Electronic components Group
Dornacher StraÙe 3
D-85622 Feldkirchen, Munich
Germany
Tel: <49> (89) 9 9180-0
Fax: <49> (89) 9 29 30 00

Hitachi Europe Ltd.
Electronic Components Group.
Whitebrook Park
Lower Cookham Road
Maidenhead
Berkshire SL6 8YA, United Kingdom
Tel: <44> (1628) 585000
Fax: <44> (1628) 778322

Hitachi Asia Pte. Ltd.
16 Collyer Quay #20-00
Hitachi Tower
Singapore 049318
Tel: 535-2100
Fax: 535-1533

Hitachi Asia Ltd.
Taipei Branch Office
3F, Hung Kuo Building, No.167,
Tun-Hwa North Road, Taipei (105)
Tel: <886> (2) 2718-3666
Fax: <886> (2) 2718-8180

Hitachi Asia (Hong Kong) Ltd.
Group III (Electronic Components)
7/F., North Tower, World Finance Centre,
Harbour City, Canton Road, Tsim Sha Tsui,
Kowloon, Hong Kong
Tel: <852> (2) 735 9218
Fax: <852> (2) 730 0281
Telex: 40815 HITEC HX

Copyright ' Hitachi, Ltd., 1999. All rights reserved. Printed in Japan.